



DIGITAL RECORDING CONSOLE

Applications Guide

Table of Contents

Introduction	1
Equipment in this Guide	1
Part 1: 02R Applications	5
System Operating Notes	5
02R Optional Interface Cards	7
Wordclock Connection and Termination	8
Wordclocks	9
Setting the 02R's Wordclock	9
1. 02R with One ADAT (Timecode on Tape Track)	12
2. 02R with ADAT & JL Cooper Datasync-2	14
3. 02R with Two ADATs & JL Cooper Datasync-2.	16
4. 02R with ADAT & BRC.	18
5. 02R with Two ADATs & BRC.	20
6. Two 02Rs with Four ADATs & BRC	22
7. 02R with Two ADATs (Timecode on Tape Track).	24
8. 02R with ADAT & RD-8	26
9. 02R with One DA-88	28
10. 02R with Two DA-88s	30
11. 02R with Four DA-88s	32
12. Two 02Rs with Four DA-88s	34
13. 02R with Akai DR8 Hard Disk Recorder	36
14. 02R with Akai DR16 Hard Disk Recorder	38
15. 02R with Analog 16-Track Multitrack Recorder	40
16. 02R with Video Machine, ADAT, & BRC	42
17. 02R with Video Machine, ADAT, & AI-2	44
18. 02R with Video Machine & DA-88	46
19. 02R with Two Fostex D-90s	48
20. 02R with Pro Tools for Music Recording	50
21. 02R with Pro Tools for Video Post	52

Introduction

This *Applications Guide* provides detailed examples of real-life 02R and 03D recording systems. The application diagrams show exactly what equipment is needed for each system and how to connect and make the relevant settings. The 02R and 03D feature as the main components throughout the applications, with various equipment by other manufacturers introduced to form complete systems.

Equipment in this Guide

The applications in this guide show how the 02R and 03D can be used with complementary equipment from other manufacturers to create complete recording and mixing systems. For those not familiar with 02R and 03D complementary equipment, here's a brief description of several such products.

Akai DR8 & DR16

The Akai DR8 is a digital hard disk recorder featuring 8-track simultaneous recording and playback. The optional ADAT (IB-804A) interface card provides 8-channel digital I/O with an 02R or 03D. The DR16 is a 16-track hard disk recorder featuring 8-track recording and 16-track playback. The optional ADAT (IB804AEX) interface card, for use only with the DR16, provides 8 digital inputs and 16 digital outputs.

Alesis ADAT Professional Digital Audio Recorder

This is the original ADAT format recorder made by Alesis. It's an eight-track recorder and uses standard S-VHS tapes. It features 16-bit, 64-times oversampling AD/DA converters, and a sampling rate of 48 kHz. A 120 minute S-VHS tape provides a total recording time of 40 minutes. Up to 16 ADATs can be connected together for a fully synchronized, sample accurate 128 track recording system. Digital I/O consists of Alesis optical connectors. These can be connected directly to an 02R or 03D with an optional CD8-AT Digital I/O card. The LRC Remote Control, which duplicates the front panel controls, comes as standard, and a full function BRC Master Remote Control is available as an option.

Alesis BRC Master Remote Control

The BRC Master Remote Control provides complete synchronized remote control of up to 16 ADATs, for 128-track recording. Sample accurate digital copy and paste editing allows digital audio data to be transferred between ADATs with no signal degradation. In addition, the BRC reads and writes SMPTE timecode, generates MIDI Timecode and MIDI clocks, reads and generates wordclock, and reads composite video sync. Autolocation provides multiple locate points per song. Seamless punch in/out is assisted with variable crossfade.

Alesis AI-2 Multipurpose Audio/Video Synchronization Interface

The Alesis AI-2 Multipurpose Audio/Video Synchronization Interface supports SMPTE timecode, Sony 9-pin protocol, video sync, 44.1 kHz and 48 kHz sampling rates, and MIDI Timecode. So ADATs can easily be slaved to video and audio master recorders. At the same time, the AI-2 can provide timecode via its timecode output, which can be fed to the 02R for use with automix.

Alesis M20

The Alesis M20 is a 20-bit, 8-track digital multitrack recorder. It can be connected to the 02R or 03D digital mixers, which both support a maximum wordlength of 24 bits, using existing CD8-AT interface cards, which do not require modification or special settings.

2 Introduction

Fostex D-90 8-track Digital Recorder

The Fostex D-90 is a digital hard disk recorder featuring 8-track simultaneous recording and playback and ADAT I/O as standard.

Fostex RD-8 Digital Multitrack Recorder

The Fostex RD-8 Digital Multitrack Recorder uses the same eight-track digital format as the Alesis ADAT, making it fully compatible. Digital I/O, Sync I/O, and meter bridge connections are also compatible with those of the ADAT. The RD-8 can be connected directly to an 02R or 03D with an optional CD8-AT Digital I/O card. The RD-8 features an on-board synchronizer for synchronization to a master recorder via timecode. Timecode offset and MIDI Machine Control are supported. LTC can be recorded on a dedicated timecode track. There are 100 locate points and variable pre and post roll times. Essentially, the RD-8 is an ADAT with some of the features of the BRC Master Remote Control and AI-2 Multipurpose Audio/Video Synchronization Interface on-board.

JL Cooper Datasync-2 Synchronizer

The JL Cooper Datasync-2 Synchronizer is a relatively low cost synchronizer that can be used to convert ADAT format sync to SMPTE timecode and MTC. It can be used to set up a cost-effective, fully synchronized 02R or 03D and ADAT digital recording system.

Midiman Syncman Plus

The Midiman Syncman Plus is an SMPTE to MTC converter and MTC generator. Front panel DIP switches are used to select the timecode type when working as a generator. For SMPTE to MTC conversion the frame rate is detected and set automatically.

TASCAM DA-88 & DA-38 Digital Multitrack Recorders

The TASCAM DA-88 Digital Multitrack Recorder is an eight-track digital recorder that uses 8 mm video tape and a 4-head mechanism. It features 16-bit AD/DA converters and 44.1 kHz and 48 kHz sampling rates. A 120 minute tape provides a recording time of 108 minutes. Up to 16 DA-88s can be connected together for a fully synchronized, sample accurate 128-track recording system. Digital I/O consists of a TASCAM TDIF-1 connector. This can be connected directly to an 02R or 03D with an optional CD8-TDII Digital I/O card. The TASCAM DA-38 is a lower-cost Digital Multitrack Recorder aimed at musicians, and provides full compatibility with tapes recorded on the DA-88.

TASCAM SY-88 Sync Board

The optional TASCAM SY-88 Sync Board provides versatile synchronization facilities for the TASCAM DA-88. It features on-board SMPTE and MIDI timecode generators, an RS422 video editor connection, and video sync inputs. An SY-88 Sync Board is essential for synchronization with 02R or 03D automation.

In a multiple DA-88 system, only the Control Master DA-88 needs to have an SY-88 Sync Board installed. Control slaves do not need SY-88 Sync Boards. Also, only the tape used in the Control Master DA-88 needs to be striped with timecode.

TASCAM MMC-38 Interface Unit

The optional TASCAM MMC-38 Interface Unit provides versatile synchronization facilities for the TASCAM DA-38. It features on-board SMPTE and MIDI timecode generators, and is essential for synchronization with 02R or 03D automation.

Part 1: 02R Applications

System Operating Notes

02R

- 02R interface cards must be screwed securely in place. Do not leave the screws out after installation as the cards will not be grounded correctly.
- If a crackling noise can be heard, make sure not more than one device is set to internal wordclock. One device should be set for internal wordclock (master) and all other devices should be set to external wordclock (slave).
- To see the version number of an 02R, hold down the UTILITY button while turning on the 02R.

02R Cascade

- In a cascaded 02R system, the ID parameter on the Cascade Configuration display must be set correctly. The setting determines the amount of delay compensation. The ID parameter is available only when a CD8-CS Cascade card is installed. The ID on the first 02R in a cascade system does not need to be set. In fact, because the IN/OUT switch on the Cascade card in the first 02R is set to OUT, the ID parameter cannot be set. The next 02R should be set to ID 1, the next to ID 2, and the last to ID 3, as shown below.

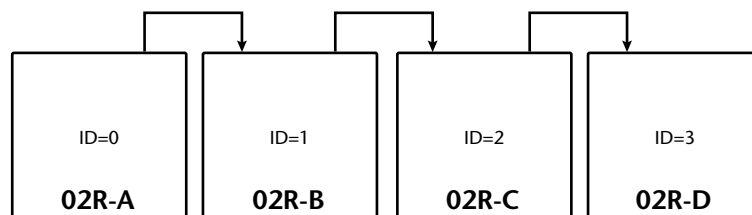

- The CD8-CS Cascade kit contains two CD8-CS cards and one 25-pin straight cable.

ADAT

- To use the ADAT's DIGITAL INPUT, press the DIGITAL IN button on the ADAT. Do not press the DIGITAL I/O button on the BRC.
- Set the DIGITAL I/O button on the BRC to OFF. This function is for direct ping-pong between multiple ADATs. If this is turned ON while connected to an 02R, bus assignments will produce unexpected results. Press the DIGITAL IN button on the ADAT to use the DIGITAL INPUT.
- To check the ADAT wordclock source, press the SET LOCATE and DIGITAL IN buttons together. The display will show "int" for internal or "digi" for external.
- The sampling rate of an ADAT can be set to either 48 kHz or 44.1 kHz. Use Fixed mode for 48 kHz and Variable mode for 44.1 kHz (using the PITCH DOWN button, set to -146 cents. At which point 44.1 appears on the display). The newer ADAT-XT has dedicated switches for selecting these two sampling rates.

6 02R Applications

- In a multiple ADAT system with no BRC, Control Slave ADATs must be powered up before the Control Master ADAT, because when the Control Master ADAT is powered up it checks how many Control Slave ADATs are connected, allocates them device numbers, and automatically sets the system wordclock.
- In an ADAT system with a BRC, the ADAT(s) must be powered up before the BRC, because when the BRC is powered up it checks how many ADATs are connected, allocates them device numbers, and automatically sets the system wordclock. The BRC works as Control Master.
- To generate timecode on a BRC, press the GEN SYNC button.
- ADAT tapes can be duplicated when ADATs are connected together directly. Be aware that a delay (27 samples) will be introduced if tapes are duplicated via the 02R.
- To see the version number of an ADAT, press the SET LOCATE and FAST FWD buttons together.
- Both the ADAT and BRC can be initialized as follows. Initialization is recommended when a BRC is behaving strangely, and the first time an ADAT is connected to a BRC. To initialize, hold down the RECORD and PLAY transport buttons while turning on the power.

DA-88

- In an 02R and DA-88 system, all connected DA-88s must be powered up even if they are not being used. Failure to do so may cause an intermittent pumping noise on the 02R.
 - The sampling rate and the use of Emphasis in a DA-88 system is determined when the DA-88 tapes are formatted. For digital recording we recommend that Emphasis be OFF.
 - In a single DA-88 system, the MACHINE ID is set to 0.
 - In a multiple DA-88 system, the Control Master is set to MACHINE ID 0 and subsequent DA-88 Control Slaves are set to MACHINE ID 1 and upwards. The Control Master DA-88 should be used for synchronized transport and locate operations.
 - The terminator bundled with the PW-88S sync cable should be connected to the SYNC OUT connector on the last DA-88 in the chain to ensure reliable synchronization.
 - The optional Tascam SY-88 Sync Board must be installed to use SMPTE timecode and MTC. This is available from Tascam. In a multiple DA-88 system, only the Control Master DA-88 needs to have an SY-88 Sync Board installed. Control Slaves do not need SY-88 Sync Boards. Also, only the tape used in the DA-88 Control Master needs to be striped with timecode.
 - The rear panel of the SY-88 Sync Board has a DIP switch labeled MODE. Set DIP switches 2 and 5 to ON (O). Set internal switch 8 on the SY-88 board marked S2 to ON.
 - To use the MTC function, the SY-88 firmware must be version 3.08 or higher.
 - Depending on the version of SY-88 Sync Board used, you may need to terminate the WORDCLOCK IN connection when the DA-88 is used as a wordclock slave.
 - On the Tascam (CD8-TD) cards there is a DIP switch that should be set to 16-bit. This is the initial setting, but you should confirm it. This switch is for use with Tascam High-Bit recording applications.
 - The Tascam 25-pin digital audio cables PW-88DL (5 m) and PW-88D (1 m) are available from Tascam.
 - DA-88 tapes can be duplicated when DA-88s are connected together directly. Be aware that a delay (24 samples) will be introduced if tapes are duplicated via the 02R.
-

- To see the version number of a DA-88, hold down the REW, F FWD, and STOP buttons when powering up the DA-88.

Akai DR8 & DR16

- When a track is armed for recording, the DR8 or DR16 will normally try to take its wordclock source from that track’s input. To prevent this, in the Digi submenu set Auto Sync to Off. Note that the Auto Sync setting is not memorized when the DR8 or DR16 is turned off, although it can be stored as part of a project.

02R Optional Interface Cards

To interface the 02R with digital multitrack equipment, optional interface cards are required. Up to four single-size interface cards can be installed in the 02R.

In the system diagrams presented in this guide, interface cards are numbered from **1** to **4**. These numbers refer to the 02R slot in which the card is installed. The following illustration shows an interface card that is installed in 02R slot **1**.



Available Cards

The following table lists the available interface cards.

Model	Description	Size	Slots
CD8-AE	Digital I/O Card (AES/EBU)	^a Double	1 – 2 (max 2 cards—16 ch)
CD8-AE-S	Digital I/O Card (AES/EBU)	^b Single	1 – 4 (max 4 cards—32 ch)
CD8-AT	Digital I/O Card (ADAT)	Single	1 – 4 (max 4 cards—32 ch)
CD8-AD	AD/DA Card	Double	1 – 2 (max 2 cards—16 ch)
CD8-CS KIT	Digital Cascade Kit	Single	Any (normally 3 or 4)
CD8-TDII	Digital I/O Card (TDIF-1)	Single	1 – 4 (max 4 cards—32 ch)
CD8-Y	Digital I/O Card (Yamaha)	Single	1 – 4 (max 4 cards—32 ch)

- a. Double size requires two slots.
- b. Single size requires one slot.

The following table shows how the inputs and outputs available at each slot correspond with the 02R inputs and outputs.

Slot	Input	Output
Slot 1	Tape In 1–8	^c BUS 1–8, AUX 1–6, Direct OUT of Mic/Line 1–8, STEREO L/R
Slot 2	Tape In 9–16	^c BUS 1–8, AUX 1–6, Direct OUT of Mic/Line 9–16, STEREO L/R
Slot 3	Mic/Line 1–8	BUS 1–8, AUX 1–6, STEREO L/R
Slot 4	Mic/Line 9–16	BUS 1–8, AUX 1–6, STEREO L/R

- c. Use the Routing display to select Bus Out or Direct Out.

Wordclock Connection and Termination

For correct operation it is essential that wordclock cabling be terminated correctly. The 02R features a wordclock termination ON/OFF (75Ω) switch. Wordclock IN and OUT connections use BNC connectors. Wordclock is a TTL signal. Three wordclock distribution examples are shown below. Note the 75Ω wordclock terminator switch settings.

1. Parallel Distribution Box

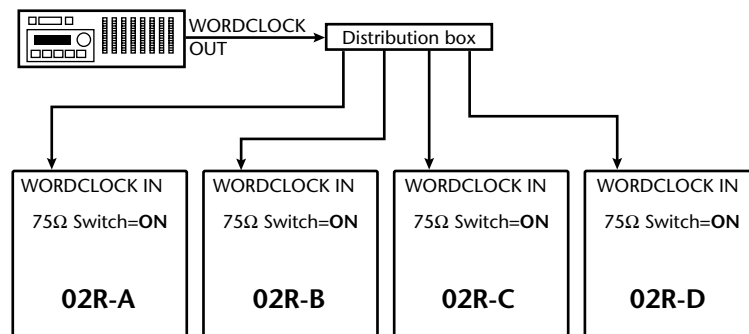

In this example, a parallel distribution box is used to distribute the wordclock signal among the four 02Rs. All 02R wordclock terminator switches are set to ON.

2. Using BNC T-bar Connectors

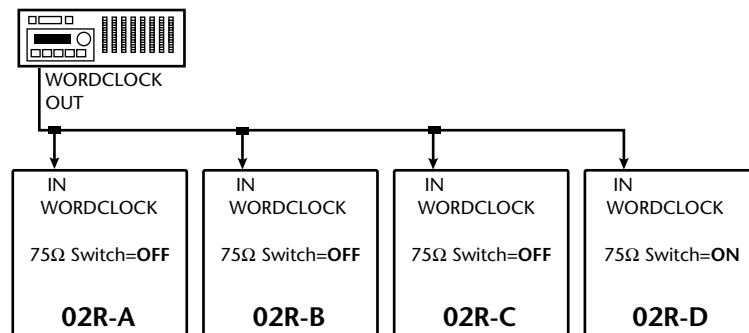

This example is similar to the above except that T-bar connectors are used. In this system, only the last 02R's wordclock terminator switch is set to ON.

3. Daisy Chain Distribution

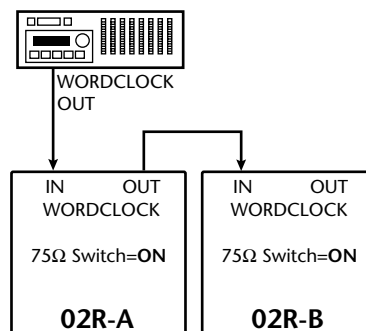

In this example, the wordclock master is a digital multitrack recorder. Both 02R wordclock terminator switches are set to ON. This method of wordclock distribution is not recommended for large systems.

Wordclocks

When several digital audio devices are configured in a system, it is essential that they are all synchronized to a single wordclock source. This is not SMPTE or MIDI timecode synchronization. Wordclock synchronization refers to the synchronization of the digital audio processing components inside each digital audio device. Typically, one digital audio device acts as wordclock master and all other devices work as wordclock slaves. The wordclock frequency is the same as the chosen sampling rate.

Even though some systems appear to work okay with several digital audio devices not sharing a common wordclock (i.e., all devices set to their own internal wordclock), digital audio data will not be processed correctly. In some systems this problem will be very audible. In others it may cause subtle distortion. Be aware of this.

In a system where all devices share a common wordclock, it is important that all devices be powered on even if just one or two devices are being used. Obviously, the wordclock master device must be powered on. Before starting a recording session it's a good idea to make sure that all wordclock slaves are locked to the master wordclock source. Most devices have front panel indicators that show whether they are locked to internal or external wordclock.

Setting the 02R's Wordclock

To set the 02R's wordclock source:

1. Press the DIGITAL I/O button repeatedly until the Word Clock Select display appears.
2. Use the cursor button to select a wordclock source.
3. Press the ENTER button.

If the 02R locks correctly to the chosen wordclock source, the respective indicator appears highlighted. See “② Wordclock Source Capable Inputs” on page 10 for a full discussion of the indicators.

As well as internal, the 02R can derive its wordclock from any one of 19 input options. It's a good idea to familiarize yourself with the various indicators on the Word Clock Select display shown below. The four sections of the display, ① to ④, are explained below.

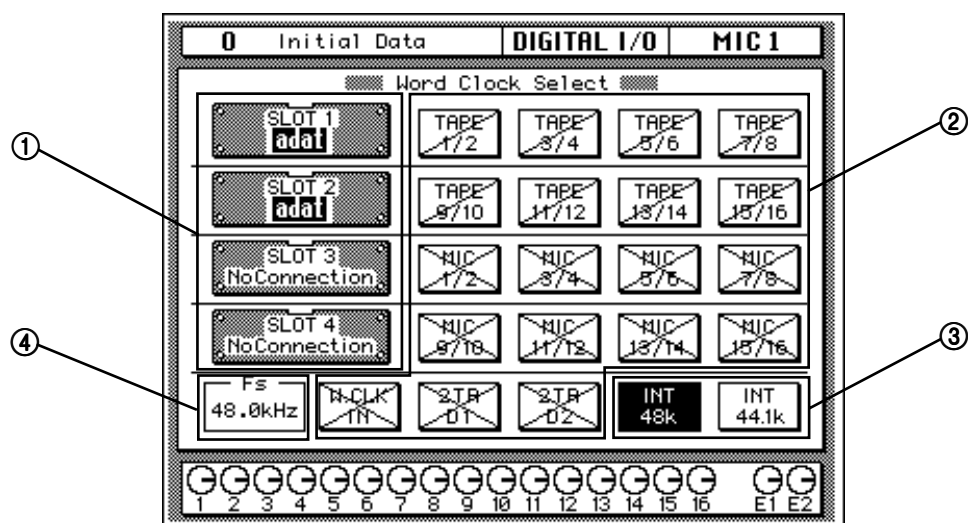

10 02R Applications

① The Four Slots

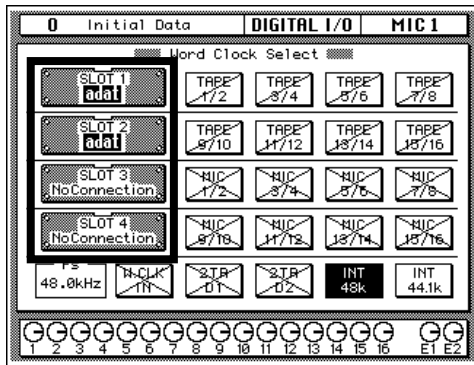

This section of the Word Clock Select display indicates the type of interface cards installed in the four slots. The following are possible:

- TASCAM
- adat
- AES/EBU
- YAMAHA
- CASCADE
- ANALOG
- No Connection

② Wordclock Source Capable Inputs

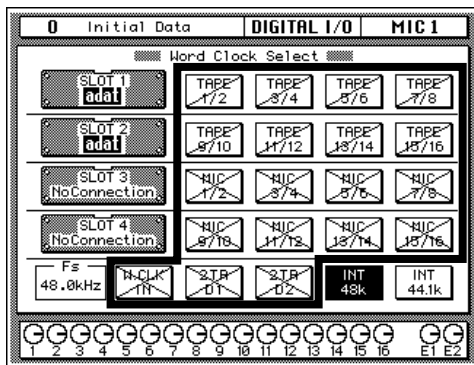

This section of the Word Clock Select display is used to set the 02R's external wordclock source. The four options to the left of each SLOT box correspond to the inputs that are available via that particular slot. The following options are available.

- TAPE 1/2–7/8—Row 1
- TAPE 9/10–15/16—Row 2
- MIC 1/2–7/8—Row 3
- MIC 9/10–15/16—Row 4
- W.CLK IN—Row 5 (BNC wordclock input)
- 2TR D1—Row 5 (2TR IN 1 AES/EBU input)
- 2TR D2—Row 5 (2TR IN 2 COAXIAL input)

The 02R's wordclock source is set by selecting one of these indicators with the cursor buttons, and then pressing the ENTER button.

The status of the wordclock capable inputs is indicated by crosses, single diagonal lines, and highlights. The key to these indicators follows.



No wordclock signal is present at this input.



A wordclock signal is present at this input but it's unlocked.



A wordclock signal is present at this input and it's locked.



This input is selected as the wordclock source, however, no wordclock signal is present.



This input is selected as the wordclock source and a wordclock signal is present. However, you should check the wordclock connections and the relationship between wordclock master and slaves.



This input is selected as the wordclock source, a wordclock signal is present, and the 02R is correctly locked to it.

③ 02R Internal Wordclock (Sampling Rate)

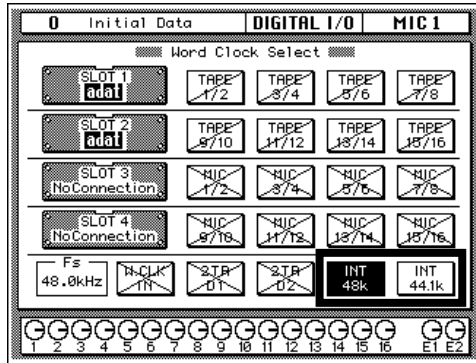

This section of the Word Clock Select display is used to set the 02R's internal wordclock rate. The following options are available.

- INT 48k
- INT 44.1k

In this example the internal sampling rate is set to 48 kHz, as shown by the highlighted box.

The 02R's wordclock source is set to one of these two internal options by selecting either 48k or 44.1k with the cursor buttons, and then pressing the ENTER button.

④ Actual Wordclock Rate

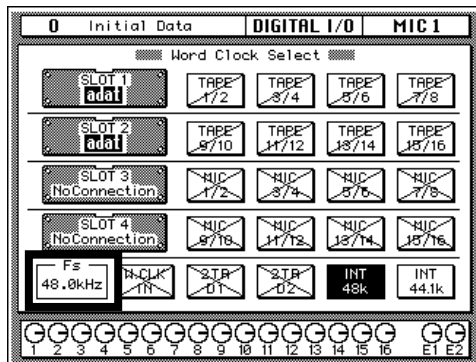

This section of the Word Clock Select display shows the actual wordclock frequency, internal or external, to within one decimal place.

1 02R with One ADAT (Timecode on Tape Track)

This application shows how the 02R can be used with one Alesis ADAT to create a 24-input, 8-track digital recording system. As shown in Figure 1, track eight of the ADAT has been striped with SMPTE timecode. This is then fed to the 02R's SMPTE TIMECODE input using a phone jack to phono cable.

The eight digital tape returns and 24 Mic/Line inputs provide up to 32 inputs at mixdown. In addition, the 02R's built-in automation and scene memory systems provide both dynamic and static mix automation referenced to timecode.

Connections

- The ADAT (CD8-AT) cards must be screwed securely in place. Do not leave the screws out after installation as the cards will not be grounded correctly.
- The Digital In/Out connectors on the 02R and ADATs are connected together using Optical Cables. Press the **DIGITAL IN** button on the ADAT to use the DIGITAL IN.
- The ADAT is connected to Slot **1** of the 02R. These tape inputs correspond to tracks one through eight.
- ADAT track eight is striped with SMPTE timecode. ADAT track eight analog out (phone jack) is connected directly to the 02R's SMPTE TIMECODE input (phono).

02R Wordclock Setup

An ADAT (CD8-AT) card is installed in Slot **1**, so any one of the first 8 tape inputs can be selected as the wordclock source on the DIGITAL I/O menu.

In Figure 1 the ADAT is shown as wordclock master. However, it could alternatively be used as wordclock slave with the 02R as master. In this case, the ADAT would be set to "digi". This can be confirmed by pressing the DIGITAL IN and SET LOCATE buttons together. The internal clock can then be set on the 02R

ADAT Wordclock Setup

The ADAT should be set as wordclock master. To confirm this, press the SET LOCATE and DIGITAL IN buttons together. The display should show "int", meaning internal wordclock. The ADAT sampling rate can be set to either 48 kHz or 44.1 kHz. Use Fixed mode for 48 kHz and Variable mode for 44.1 kHz (using the PITCH DOWN button, set to -147 cents. At which point "-146, 44.1, -148" appears on the display). The newer ADAT-XT has dedicated switches for selecting these two sampling rates.

Notes

- Press the DIGITAL IN button on the ADAT to use the DIGITAL INPUT.
-

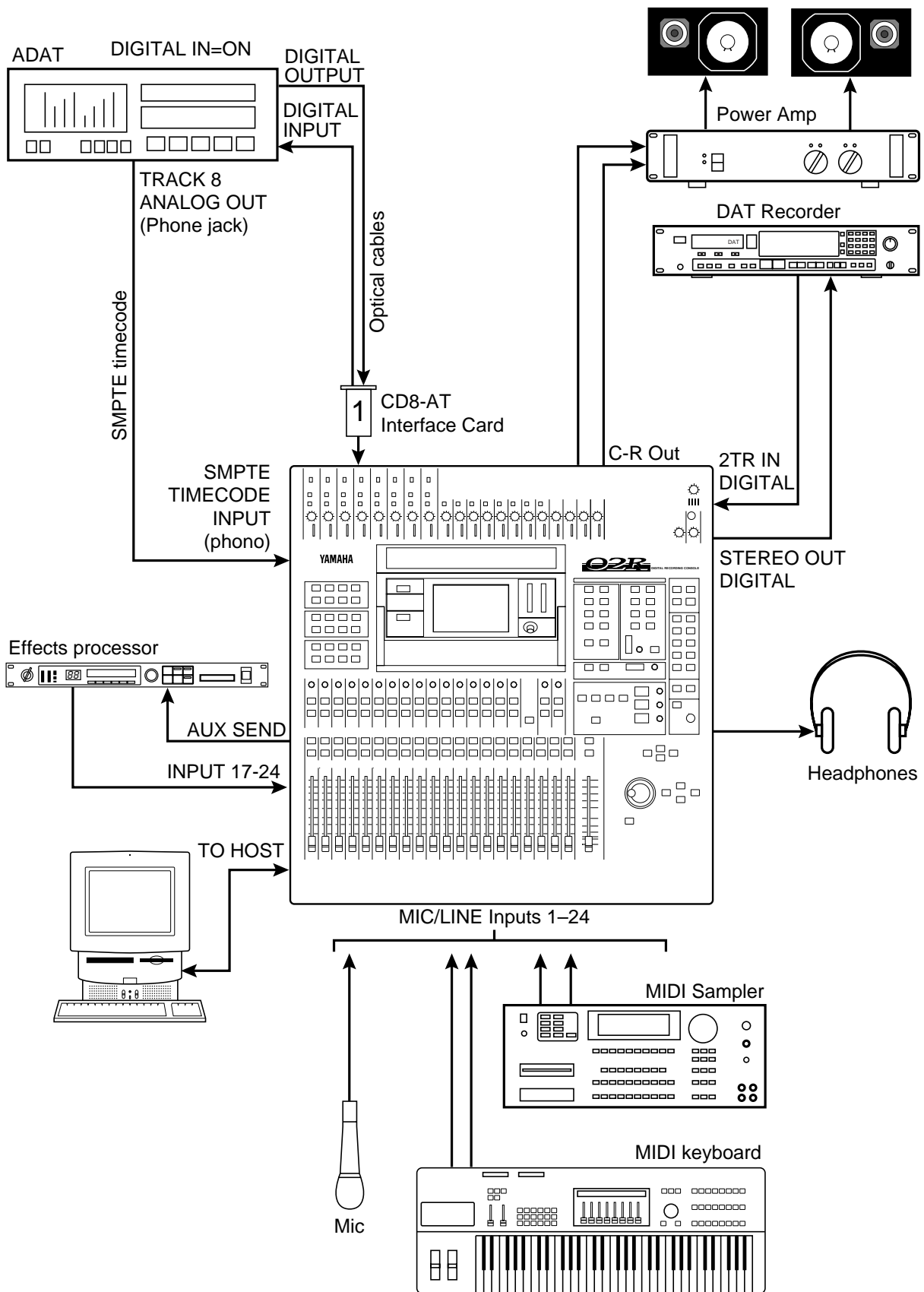

Figure 1 O2R with One ADAT (Timecode on Tape Track)

2

02R with ADAT & JL Cooper Datasync-2

This application shows how the 02R can be used with a JL Cooper Datasync-2 Synchronizer to create a 24-input, 8-track digital recording system. The JL Cooper Datasync-2 Synchronizer is a cost-effective device for setting up a synchronized 02R and ADAT system. The eight digital tape returns and 24 Mic/Line inputs provide up to 32 inputs at mixdown. In addition, the 02R's built-in automation and scene memory systems provide both dynamic and static mix automation referenced to MIDI timecode.

Connections

- The ADAT (CD8-AT) card must be screwed securely in place. Do not leave the screws out after installation as the card will not be grounded correctly.
- The Digital In/Out connectors on the 02R and ADAT are connected together using Optical Cables. Press the **DIGITAL IN** button on the ADAT to use the DIGITAL IN.
- The ADAT's eight tracks connect to 02R slot **1**, tape inputs one through eight.
- The JL Cooper Datasync-2 Synchronizer converts the ADAT's internal timecode to MIDI timecode or SMPTE timecode.
- A 9-pin Sync cable for connecting the ADAT and Datasync-2 is available from Alesis.

02R Wordclock Setup

The ADAT (CD8-AT) card is installed in Slot **1**, so any pair of the first eight tape inputs can be selected as the wordclock source on the DIGITAL I/O menu.

ADAT Wordclock Setup

The ADAT should be set as wordclock master. To confirm this, press the SET LOCATE and DIGITAL IN buttons together. The display should show "int", meaning internal wordclock. The ADAT sampling rate can be set to either 48 kHz or 44.1 kHz. Use Fixed mode for 48 kHz and Variable mode for 44.1 kHz (using the PITCH DOWN button, set to -147 cents. At which point "-146, 44.1, -148" appears on the display). The newer ADAT-XT has dedicated switches for selecting these two sampling rates.

In Figure 2 the ADAT is shown as wordclock master. However, it could alternatively be used as wordclock slave with the 02R as master. In this case, the ADAT would be set to "digi". This can be confirmed by pressing the DIGITAL IN and SET LOCATE buttons together. The internal clock can then be set on the 02R.

Notes

- Press the DIGITAL IN button on the ADAT to use the DIGITAL INPUT.
-

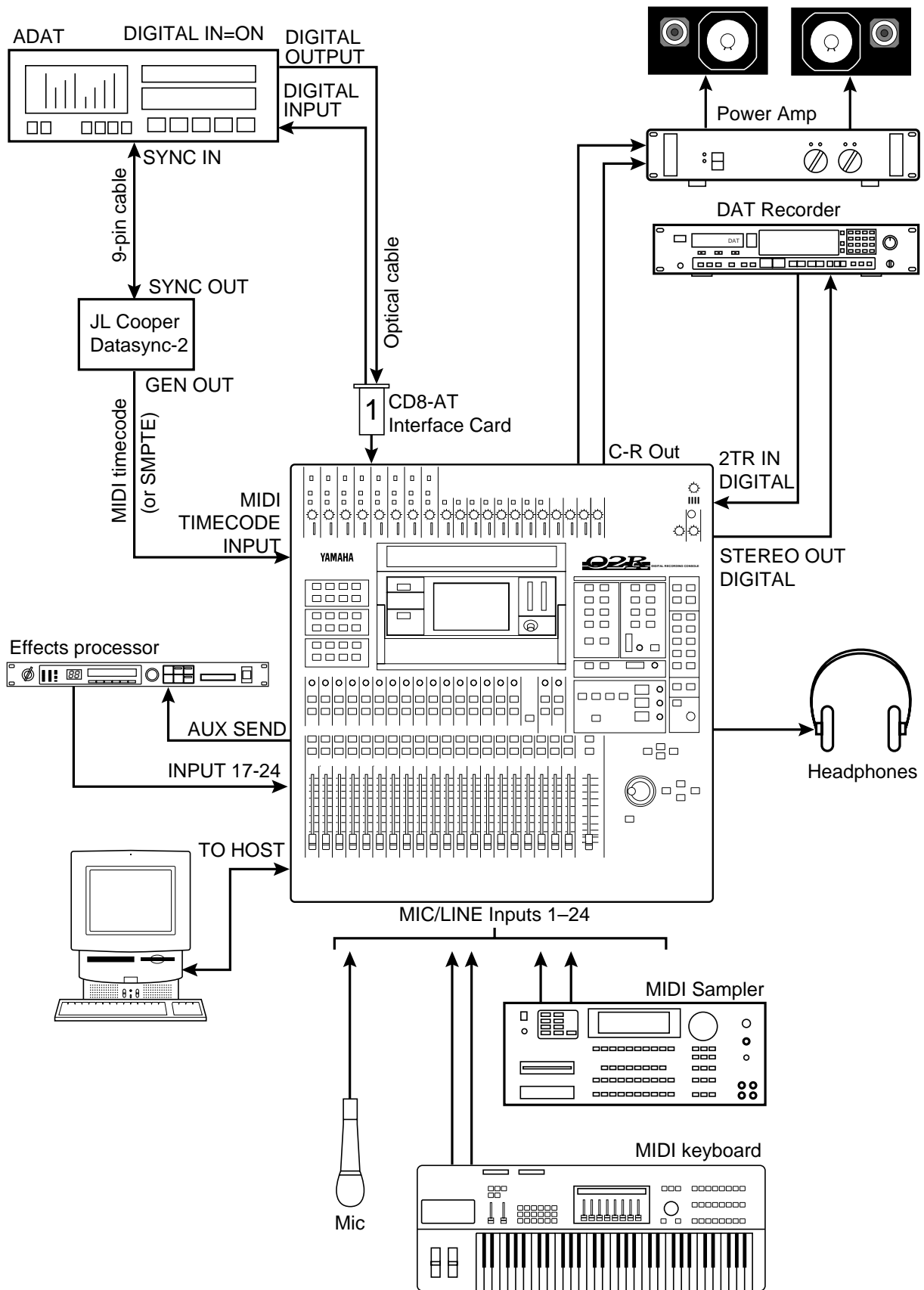

Figure 2 O2R with ADAT & JL Cooper Datasync-2

3

02R with Two ADATs & JL Cooper Datasync-2

This application shows how the 02R can be used with two Alesis ADATs and JL Cooper Datasync-2 Synchronizer to create a 24-input, 16-track digital recording system. The JL Cooper Datasync-2 Synchronizer is a cost-effective device for setting up a synchronized 02R and ADAT system.

The 16 digital tape returns and 24 Mic/Line inputs provide up to 40 inputs at mixdown. In addition, the 02R's built-in automation and scene memory systems provide both dynamic and static mix automation referenced to MIDI timecode.

Connections

- The ADAT (CD8-AT) cards must be screwed securely in place. Do not leave the screws out after installation as the cards will not be grounded correctly.
- The Digital In/Out connectors on the 02R and ADAT are connected together using Optical Cables. Press the **DIGITAL IN** buttons on the ADATs to use the DIGITAL INs.
- ADAT-A is connected to Slot **1** of the 02R and the tape inputs correspond to tracks one through eight.
- ADAT-B is connected to Slot **2** of the 02R and the tape inputs correspond to tracks nine through sixteen.
- The JL Cooper Datasync-2 Synchronizer converts the ADAT's internal timecode to MIDI timecode or SMPTE timecode.
- 9-pin Sync cables for connecting the ADATs and Datasync-2 are available from Alesis.

02R Wordclock Setup

ADAT (CD8-AT) cards are installed in Slot **1** and Slot **2**, so any pair of the tape inputs can be selected as the wordclock source on the DIGITAL I/O menu.

ADAT Wordclock Setup

ADAT-A should be set as wordclock master. To confirm this, press the SET LOCATE and DIGITAL IN buttons together. The display should show "int", meaning internal wordclock. The ADAT sampling rate can be set to either 48 kHz or 44.1 kHz. Use Fixed mode for 48 kHz and Variable mode for 44.1 kHz (using the PITCH DOWN button, set to -147 cents. At which point "-146, 44.1, -148" appears on the display). The newer ADAT-XT has dedicated switches for selecting these two sampling rates.

Notes

- Press the DIGITAL IN buttons on the ADATs to use the DIGITAL INPUTs.
 - ADAT-B must be powered up before ADAT-A, because when ADAT-A is powered up it checks how many ADATs are connected, allocates them device numbers, and automatically sets the system word clock. ADAT-A works as Control Master.
-

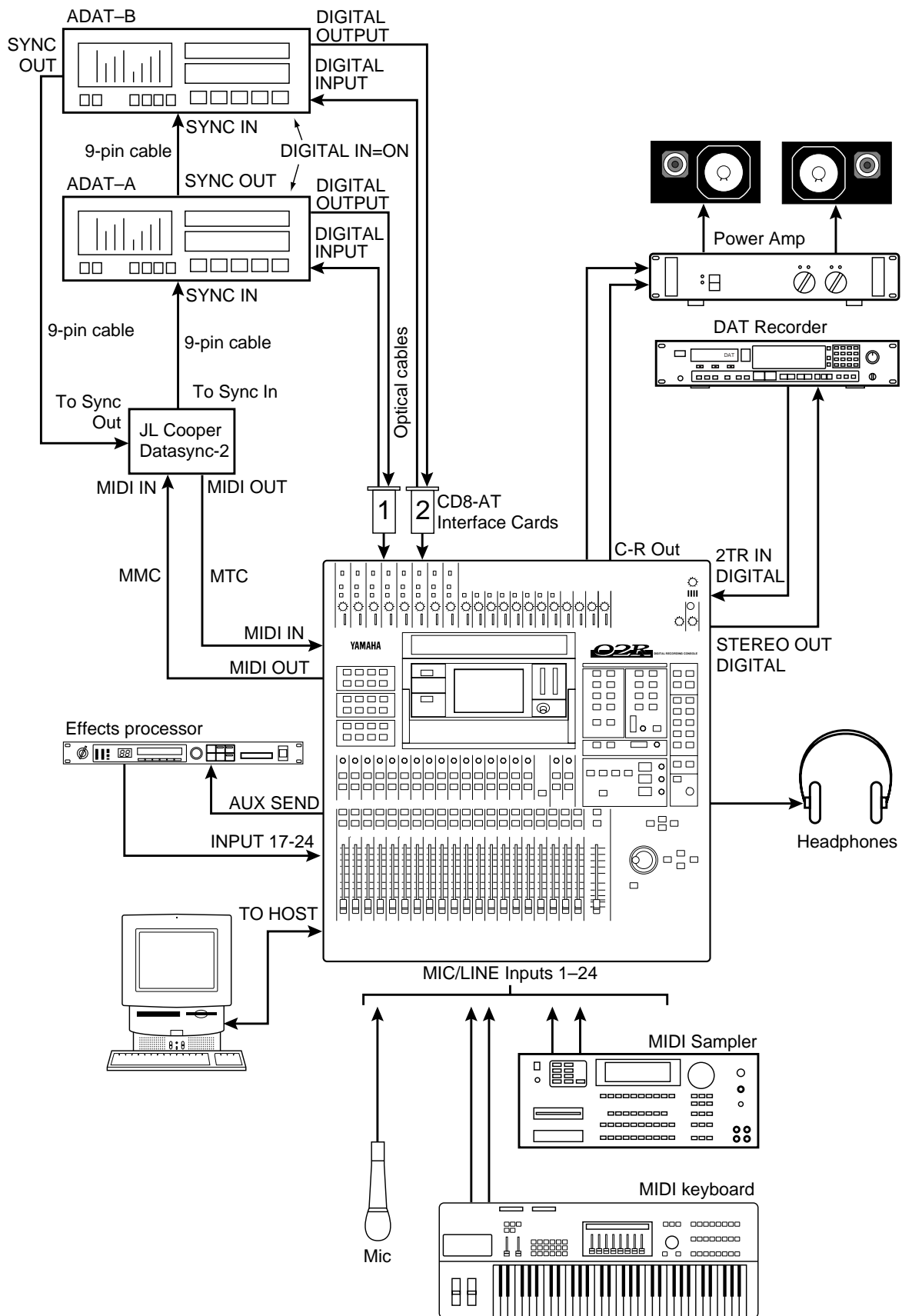

Figure 3 O2R with Two ADATs & JL Cooper Datasync-2

4

02R with ADAT & BRC

This application shows how the 02R can be used with an Alesis ADAT and BRC Master Remote Control to create a 24-input, 8-track digital recording system. The eight digital tape returns and 24 Mic/Line inputs provide up to 32 inputs at mixdown. In addition, the 02R's built-in automation and scene memory systems provide both dynamic and static mix automation referenced to timecode.

Connections

- The ADAT (CD8-AT) card must be screwed securely in place. Do not leave the screws out after installation as the card will not be grounded correctly.
- The Digital In/Out connectors on the 02R and ADAT are connected together using Optical Cables. Press the **DIGITAL IN** button on the ADAT to use the DIGITAL IN.
- The ADAT's eight tracks connect to 02R slot **[1]**, tape inputs one through eight.
- The Alesis BRC Master Remote Control can control up to 16 ADATs (i.e. 128 tracks).
- A 9-pin sync cable for connecting the ADAT and BRC is available from Alesis.
- The BRC provides ADAT timecode to SMPTE timecode conversion. In addition, a timecode offset can be specified, so the automix start time can be adjusted.
- The 75 ohm wordclock termination switch on the back of the 02R is set to ON.

02R Wordclock Setup

On the DIGITAL I/O menu, the wordclock source should be set to W.CLK.

ADAT & BRC Wordclock Setup

The BRC works as wordclock master and the ADAT locks to it automatically via the 9-pin sync cable. The sampling rate can be set to either 48 kHz or 44.1 kHz. Use Fixed mode for 48 kHz and Variable mode for 44.1 kHz (using the PITCH DOWN button, set to -147 cents. At which point “-146, 44.1, -148” appears on the display). The newer ADAT-XT has dedicated switches for selecting these two sampling rates.

Notes

- Press the DIGITAL IN button on the ADAT to use the DIGITAL INPUT.
 - The ADAT must be powered up before the BRC, because when the BRC is powered up it checks how many ADATs are connected, allocates them device numbers, and automatically sets the system wordclock.
 - To generate timecode on the BRC, press the GEN SYNC button.
 - On the BRC, set the DIGITAL I/O button to OFF. This function is for direct ping-pong between multiple ADATs. If this is turned ON while connected to an 02R, bus assignments will produce unexpected results. Press the DIGITAL IN button on the ADAT to use the DIGITAL INPUT.
-

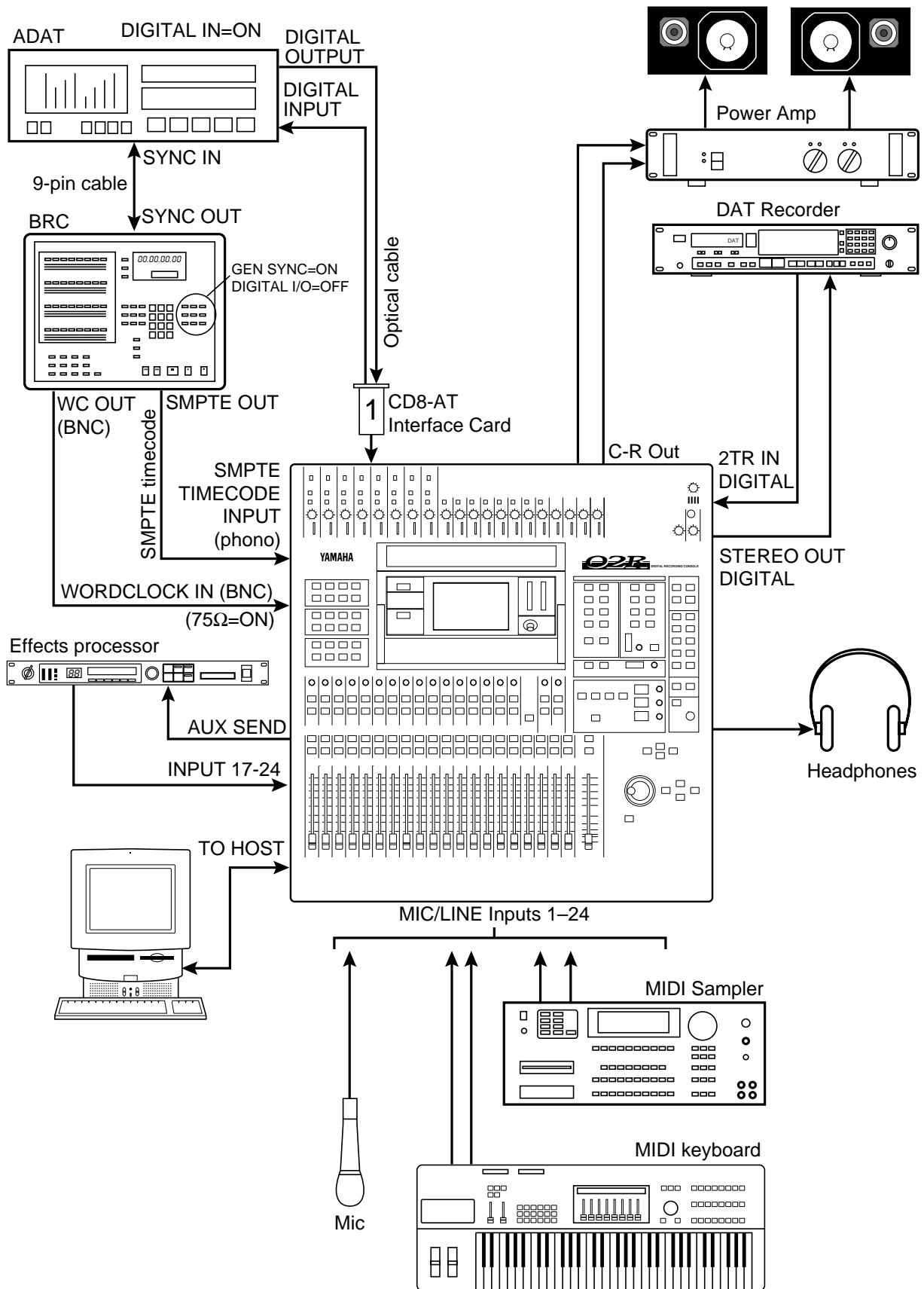

Figure 4 O2R with ADAT & BRC

5 02R with Two ADATs & BRC

This application shows how the 02R can be used with two Alesis ADATs and a BRC Master Remote Control to create a 24-input, 16-track digital recording system. The 16 digital tape returns and 24 Mic/Line inputs provide up to 40 inputs at mixdown. In addition, the 02R's built-in automation and scene memory systems provide both dynamic and static mix automation referenced to timecode.

Connections

- The ADAT (CD8-AT) cards must be screwed securely in place. Do not leave the screws out after installation as the cards will not be grounded correctly.
- The Digital In/Out connectors on the 02R and ADAT are connected together using Optical Cables. Press the **DIGITAL IN** buttons on the ADATs to use the DIGITAL IN.
- ADAT-A is connected to Slot **1** of the 02R and the tape inputs correspond to tracks one through eight.
- ADAT-B is connected to Slot **2** of the 02R and the tape inputs correspond to tracks nine through sixteen.
- The Alesis BRC Master Remote Control can control up to 16 ADATs (i.e. 128 tracks).
- A 9-pin sync cable for connecting the ADAT and BRC is available from Alesis.
- The BRC provides ADAT timecode to SMPTE timecode conversion. In addition, a timecode offset can be specified, so the automix start time can be adjusted.
- The 75 ohm wordclock termination switch on the back of the 02R is set to ON.

02R Wordclock Setup

On the DIGITAL I/O menu, the wordclock source should be set to W.CLK.

ADAT & BRC Wordclock Setup

The BRC works as wordclock master and the two ADATs locks to it automatically via the 9-pin sync cables. The sampling rate can be set to either 48 kHz or 44.1 kHz. Use Fixed mode for 48 kHz and Variable mode for 44.1 kHz (using the PITCH DOWN button, set to -147 cents. At which point “-146, 44.1, -148” appears on the display). The newer ADAT-XT has dedicated switches for selecting these two sampling rates.

Notes

- The ADATs must be powered up before the BRC and in the following order: B then A. This is because when the BRC is powered up it checks how many ADATs are connected, allocates them device numbers, and automatically sets the system clock.
 - To generate timecode on the BRC, press the GEN SYNC button.
 - On the BRC, set the DIGITAL I/O button to OFF. This function is for direct ping-pong between multiple ADATs. If this is turned ON while connected to an 02R, bus assignments will produce unexpected results. Press the DIGITAL IN button on the ADAT to use the DIGITAL INPUT.
-

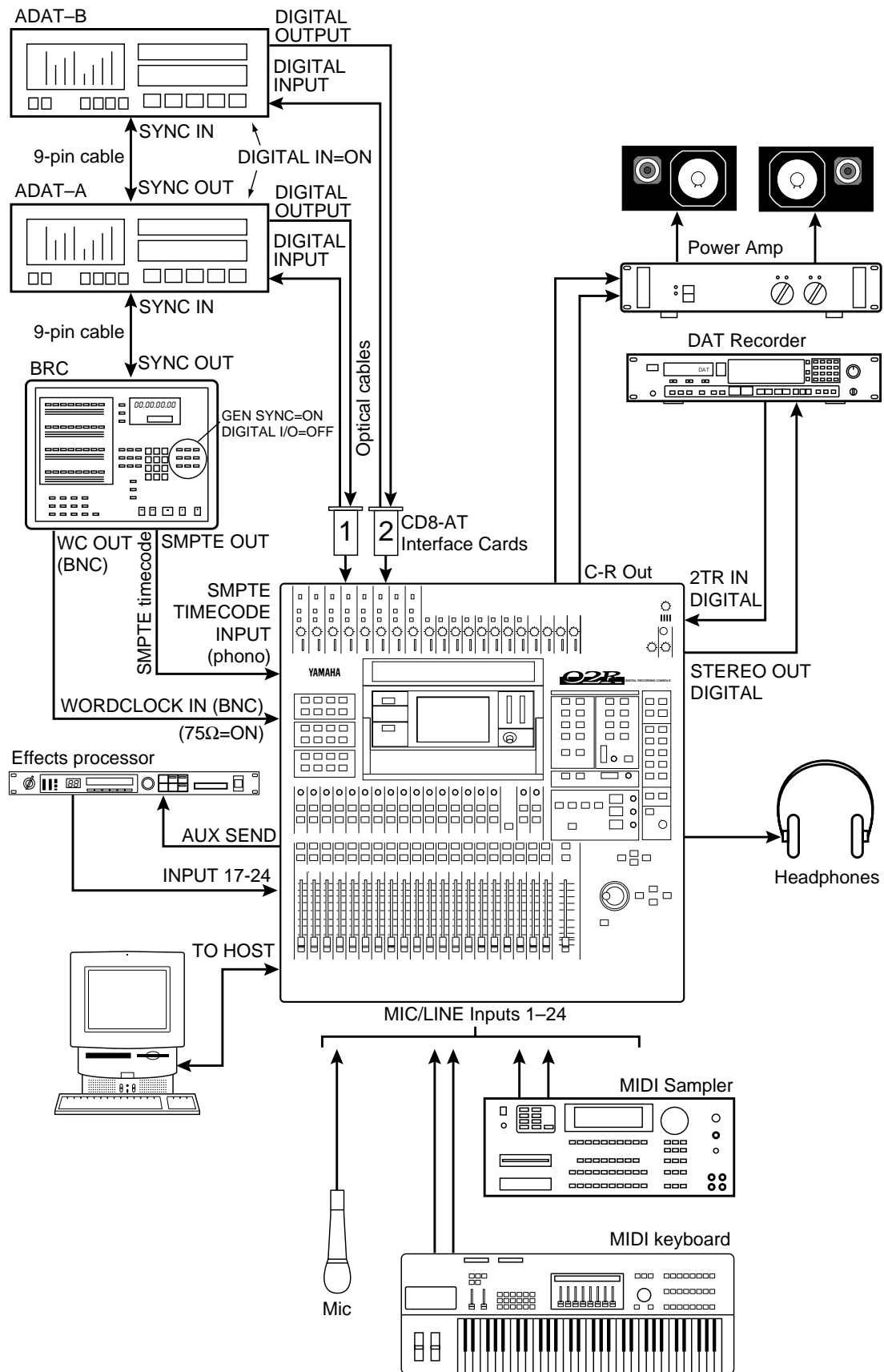

Figure 5 O2R with Two ADATs & BRC

6

Two 02Rs with Four ADATs & BRC

This application shows how two 02Rs can be used with four Alesis ADATs and a BRC Master Remote Control to create a 48-input, 32-track digital recording system. The 32 digital tape returns and 48 Mic/Line inputs provide up to 80 inputs at mixdown. In addition, the 02R's built-in automation and scene memory systems provide both dynamic and static mix automation referenced to timecode.

The two 02Rs are cascaded together using a 25-pin straight cable and two Cascade (CD8-CS) cards, which are installed in Slot **3** of each 02R (could be Slot **4**). The cascade connection carries the eight buses, any four of the eight AUX buses, Stereo bus, and Solo bus. This allows both consoles to work together as one large 80-input mixing console. The master section of 02R-B is used for monitoring and two-track operations. The studio monitors and two-track recording equipment are also connected to this 02R.

Connections

- The ADAT (CD8-AT) and Cascade (CD8-CS) cards must be screwed securely in place. Do not leave the screws out after installation as the cards will not be grounded correctly.
- The Digital In/Out connectors on the 02R and ADAT are connected together using the Optical Cable. Press the **DIGITAL IN** buttons on the ADATs to use the DIGITAL IN.
- ADAT-A is connected to Slot **1** of 02R-A and the tape inputs correspond to tracks one through eight. ADAT-B is connected to Slot **2** of 02R-A and the tape inputs correspond to tracks nine through sixteen. ADAT-C is connected to Slot **1** of 02R-B and the tape inputs correspond to tracks 17 through 24. ADAT-D is connected to Slot **2** of 02R-B and the tape inputs correspond to tracks 25 through 32.
- The Alesis BRC Master Remote Control can control up to 16 ADATs (i.e. 128 tracks).
- The BRC provides ADAT timecode to SMPTE timecode conversion. In addition, a timecode offset can be specified, so the automix start time can be adjusted.
- The 75 ohm wordclock termination switches on both 02Rs is set to ON.

02R Wordclock Setup

On the DIGITAL I/O menu, the wordclock source should be set to W.CLK.

ADAT & BRC Wordclock Setup

The BRC works as wordclock master and the four ADATs follows it automatically via the 9-pin sync cables. The sampling rate can be set to either 48 kHz or 44.1 kHz. Use Fixed mode for 48 kHz and Variable mode for 44.1 kHz (using the PITCH DOWN button, set to -147 cents. At which point “-146, 44.1, -148” appears on the display). The newer ADAT-XT has dedicated switches for selecting these two sampling rates.

Notes

- The ADATs must be powered up before the BRC and in the following order: D, C, B, A. This is because when the BRC is powered up it checks how many ADATs are connected, allocates them device numbers, and automatically sets the system clock.
 - The rear of the Cascade (CD8-CS) cards have an IN/OUT switch. On 02R-A is set to OUT. On 02R-B it is set to IN.
 - To generate timecode on the BRC, press the GEN SYNC button.
 - The optional CD8-CS kit contains two CD8-CS cards and one 25-pin straight cable.
-

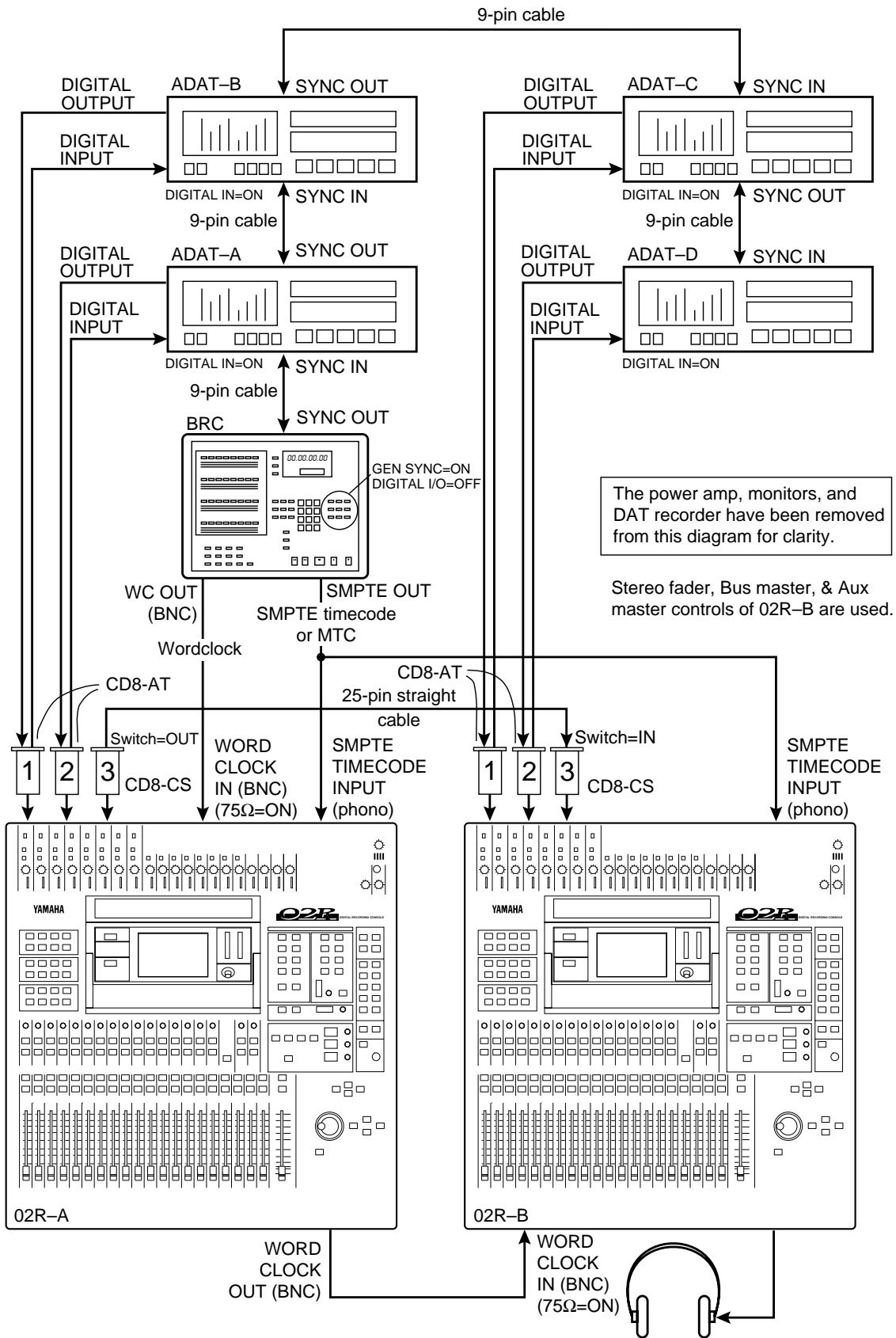

Figure 6 Two O2Rs with Four ADATs & BRC

7

02R with Two ADATs (Timecode on Tape Track)

This application shows how the 02R can be used with two Alesis ADATs to create a 24-input, 16-track digital recording system. As shown in Figure 7, track eight of ADAT–A has been striped with SMPTE timecode. This is then fed to the 02R’s SMPTE TIMECODE input using a phone jack to phono cable.

The 16 digital tape returns and 24 Mic/Line inputs provide up to 40 inputs at mixdown. In addition, the 02R’s built-in automation and scene memory systems provide both dynamic and static mix automation referenced to timecode.

Connections

- The ADAT (CD8-AT) cards must be screwed securely in place. Do not leave the screws out after installation as the cards will not be grounded correctly.
- The Digital In/Out connectors on the 02R and ADATs are connected together using Optical Cables. Press the **DIGITAL IN** buttons on the ADATs to use the DIGITAL IN.
- ADAT–A is connected to Slot **1** of the 02R. These tape inputs correspond to tracks one through eight.
- ADAT–B is connected to Slot **2** on the 02R. These tape inputs correspond to tracks nine through sixteen.
- ADAT track eight is striped with SMPTE timecode. ADAT track eight analog out (phone jack) output is connected directly to the 02R’s SMPTE TIMECODE input (phono).

02R Wordclock Setup

ADAT (CD8-AT) cards are installed in Slot **1** and Slot **2**, so any one of the first 16 tape inputs can be selected as the wordclock source on the DIGITAL I/O menu.

ADAT Wordclock Setup

ADAT–A should be set as wordclock master. To confirm this, press the SET LOCATE and DIGITAL IN buttons together. The display should show “int”, meaning internal wordclock. The ADAT sampling rate can be set to either 48 kHz or 44.1 kHz. Use Fixed mode for 48 kHz and Variable mode for 44.1 kHz (using the PITCH DOWN button, set to –147 cents. At which point “–146, 44.1, –148” appears on the display). The newer ADAT-XT has dedicated switches for selecting these two sampling rates.

Notes

- Press the DIGITAL IN button on the ADAT to use the DIGITAL INPUT.
 - ADAT–B must be powered up before ADAT–A, because when ADAT–A is powered up it checks how many ADATs are connected, allocates them device numbers, and automatically sets the system word clock. ADAT–A works as Control Master.
-

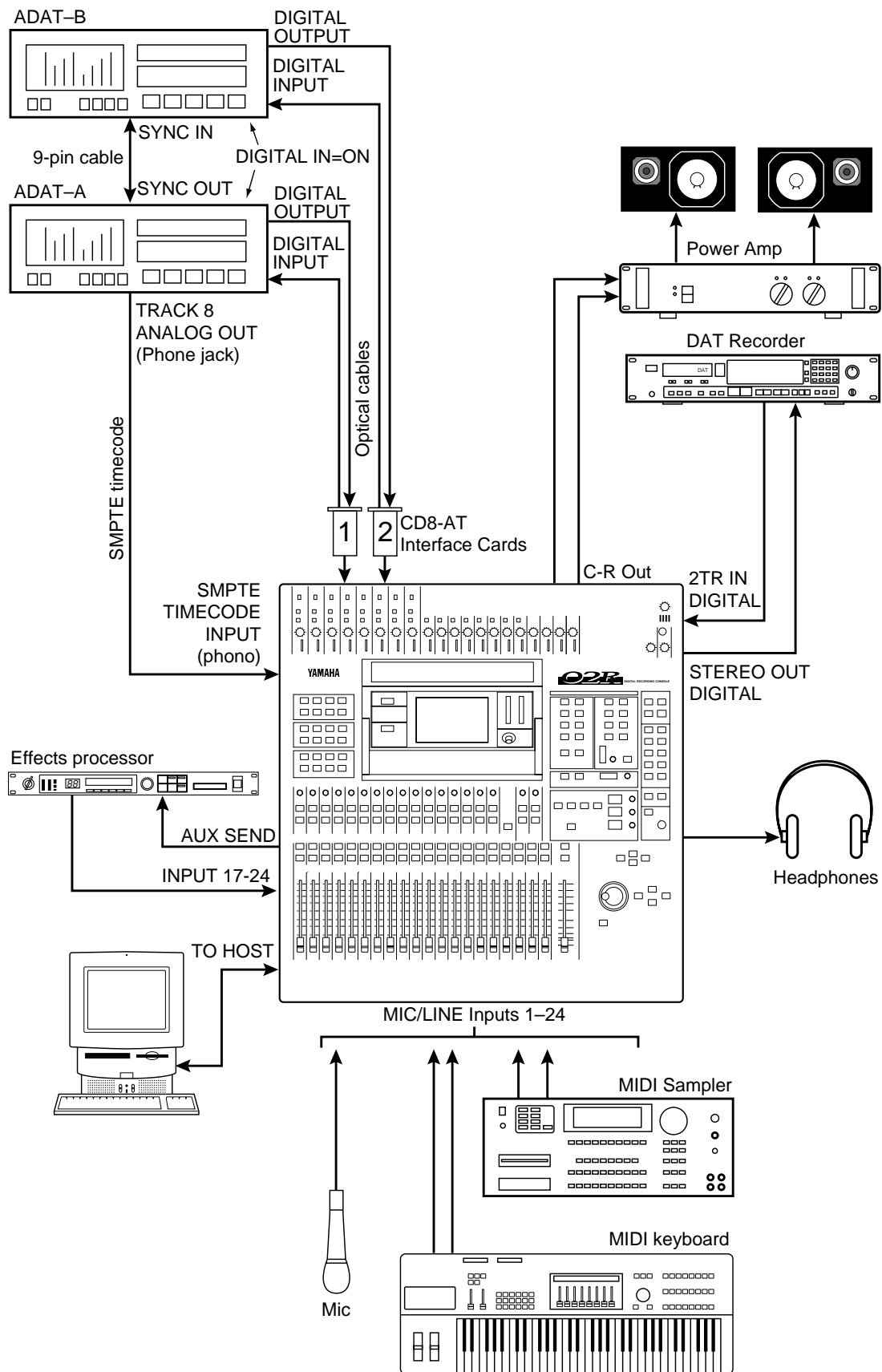

Figure 7 O2R with Two ADATs (Timecode on Tape Track)

8

02R with ADAT & RD-8

This application shows how the 02R can be used with one Alesis ADAT and one Fostex RD-8 to create a 24-input, 16-track digital recording system. RD-8 is an ADAT compatible digital recorder made by Fostex. The 16 digital tape returns and 24 Mic/Line inputs provide up to 32 inputs at mixdown. In addition, the 02R's built-in automation and scene memory systems provide both dynamic and static mix automation referenced to timecode.

Connections

- The ADAT (CD8-AT) must be screwed securely in place. Do not leave the screws out after installation as the cards will not be grounded correctly.
- The Digital In/Out connectors on the 02R, ADAT, and RD-8 are connected together using Optical Cables. Press the **DIGITAL IN** buttons on the ADAT and RD-8 to use the DIGITAL INs.
- The RD-8 is connected to Slot **1** of the 02R. These tape inputs correspond to tracks one through eight. The ADAT is connected to Slot **2** of the 02R. These tape inputs correspond to tracks nine through sixteen.
- A 9-pin Sync cable for connecting the ADAT and RD-8 is available from Alesis or Fostex.
- The RD-8 can output SMPTE timecode. In addition, a timecode offset can be specified, so the 02R automix start time can be adjusted.
- The 75 ohm wordclock termination switch on the back of the 02R is set to ON.

02R Wordclock Setup

On the DIGITAL I/O menu, the wordclock source should be set to W.CLK.

ADAT & RD-8 Wordclock Setup

The RD-8 works as wordclock master and the ADAT locks to it automatically via the 9-pin sync cable. The sampling rate can be set to either 48 kHz or 44.1 kHz on the RD-8 menu.

Notes

- Press the DIGITAL IN button on the ADAT to use the DIGITAL INPUT.
 - The ADAT must be powered up before the RD-8, because when the RD-8 is powered up it checks how many ADATs are connected, allocates them device numbers, and automatically sets the system word clock. RD-8 works as Control Master.
-

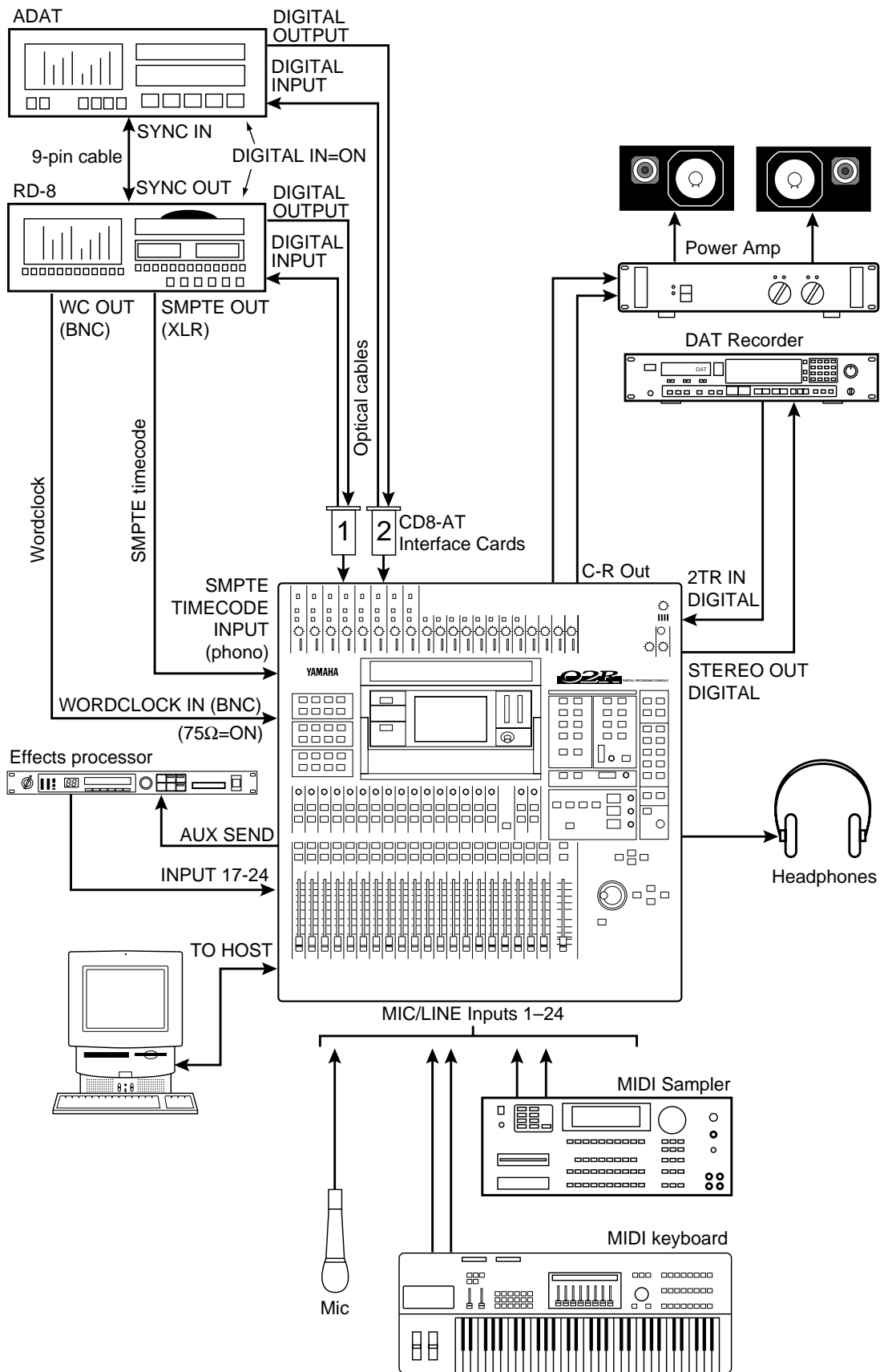

Figure 8 02R with ADAT & RD-8

9 02R with One DA-88

This application shows how the 02R can be used with a Tascam DA-88 to create a 24-input, 8-track digital recording system. The eight digital tape returns and 24 Mic/Line inputs provide up to 32 inputs at mixdown. In addition, the 02R's built-in automation and scene memory systems provide both dynamic and static mix automation referenced to timecode.

Connections

- The Tascam (CD8-TD) card must be screwed securely in place. Do not leave the screws out after installation as the card will not be grounded correctly.
- The Tascam digital audio cable (PW-88DL) carries the eight tape sends and eight tape returns.
- The DA-88 is connected to Slot **[1]** of the 02R. These tape inputs correspond to tracks one through eight.
- The optional SY-88 Sync Board is required. The DA-88 has a dedicated timecode track and can output SMPTE timecode or MTC. In addition, a timecode offset can be specified on the DA-88, so the 02R automix start time can be adjusted. The DA-88 also has the ability to re-stripe the timecode track.
- The 75 ohm wordclock termination switch on the back of the 02R is set to ON.

02R Wordclock Setup

On the DIGITAL I/O menu, the wordclock source should be set to W.CLK.

DA-88 Wordclock Setup

The DA-88 works as wordclock master. Wordclock is fed to the 02R using a BNC to BNC cable. The sampling rate is set when the DA-88 tape is formatted. This can be either 48 kHz or 44.1 kHz. After formatting, the sampling rate is determined by the formatted tape.

Notes

- The DA-88 must be powered up even when it is not being used. Failure to do so may cause an intermittent pumping noise on the 02R.
 - On the DA-88 rear panel, set the MACHINE ID to 0.
 - The optional **Tascam SY-88 Sync Board** must be installed to use SMPTE timecode and MTC. This is available from Tascam.
 - The rear panel of the SY-88 Sync Board has a DIP switch labeled MODE. Set DIP switches 2 and 5 to ON (O). Set internal switch 8 on the SY-88 board marked S2 to ON.
 - To use the MTC function, the SY-88 firmware must be version 3.08 or higher.
 - On the Tascam (CD8-TD) card there is a DIP switch that should be set to 16-bit. This is the initial setting, but you should confirm it. This switch is for use with Tascam High-Bit recording applications.
 - Tascam 25-pin digital audio cables PW-88DL (5 m) and PW-88D (1 m) are available from Tascam.
-

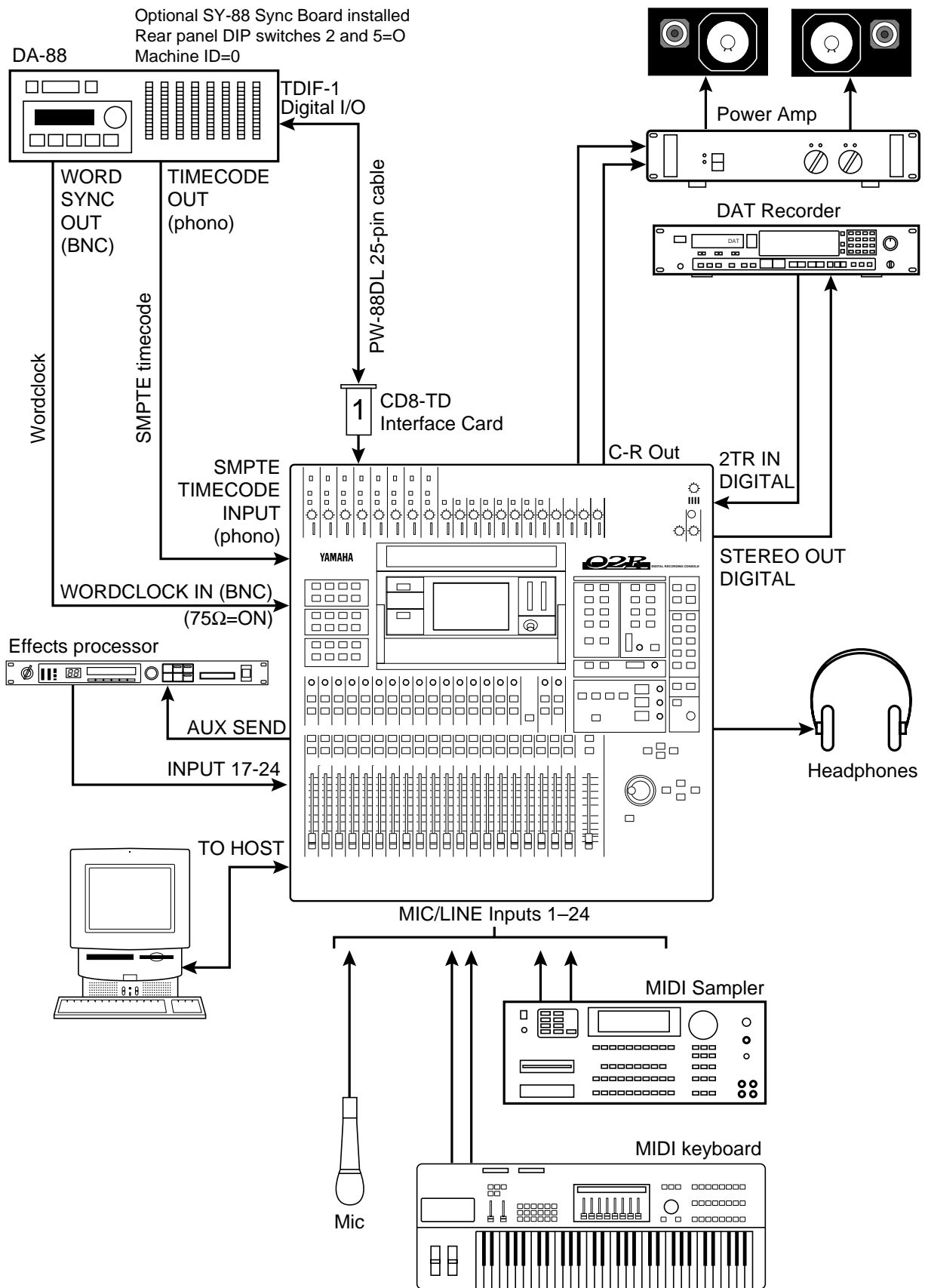

Figure 9 O2R with One DA-88

10 02R with Two DA-88s

This application shows how the 02R can be used with two Tascam DA-88s to create a 24-input, 16-track digital recording system. The 16 tape returns and 24 Mic/Line inputs provide up to 40 inputs at mixdown. In addition, the 02R's built-in automation and scene memory systems provide both dynamic and static mix automation referenced to timecode.

Connections

- The Tascam (CD8-TD) cards must be screwed securely in place. Do not leave the screws out after installation as the cards will not be grounded correctly.
- The Tascam digital audio cables (PW-88DL) carry the eight tape sends and returns.
- DA-88-A is connected to Slot **1** of the 02R. These tape inputs correspond to tracks one through eight. DA-88-B is connected to Slot **2** of the 02R. These tape inputs correspond to tracks nine through sixteen.
- The optional SY-88 Sync Board is required for DA-88-A. This enables the dedicated timecode track, which can be re-stripped at anytime, and provides SMPTE timecode and MTC outputs. A timecode offset can be specified on DA-88-A, so the 02R automix start time can be adjusted.

02R Wordclock Setup

On the DIGITAL I/O menu, the wordclock source should be set to W.CLK.

DA-88 Wordclock Setup

DA-88-A works as wordclock master. Wordclock is fed to the 02R using a BNC to BNC cable, and to the DA-88-B using a PW-88S 15-pin sync cable. The sampling rate is set when the DA-88 tapes are formatted. This can be either 48 kHz or 44.1 kHz. After formatting, the sampling rate is determined by the formatted tape.

Notes

- The DA-88s must be powered up even when they are not being used. Failure to do so may cause an intermittent pumping noise on the 02R.
 - DA-88-A is set to MACHINE ID 0. DA-88-B is set to MACHINE ID 1. Since DA-88-A works as Control Master, it should be used for synchronized transport and locate operations.
 - The optional **Tascam SY-88 Sync Board** must be installed in DA-88-A to use SMPTE timecode and MTC. This is available from Tascam. DA-88-B does not require the SY-88 Sync Board nor does its tape have to be striped with timecode. It is synchronized to DA-88-A via the PW-88S 15-pin sync cable.
 - The terminator bundled with the PW-88S sync cable should be connected to the SYNC OUT on DA-88-B to ensure reliable synchronization.
 - The rear panel of the SY-88 Sync Board has a DIP switch labeled MODE. Set DIP switches 2 and 5 to ON (O). Set internal switch 8 on the SY-88 board marked S2 to ON.
 - To use the MTC function, the SY-88 firmware must be version 3.08 or higher.
 - On the Tascam (CD8-TD) card there is a DIP switch that should be set to 16-bit. This is the initial setting, but you should confirm it. This switch is for use with Tascam High-Bit recording applications.
 - Tascam 25-pin digital audio cables PW-88DL (5 m) and PW-88D (1 m), and the 15-pin PW-88S sync cable are available from Tascam.
-

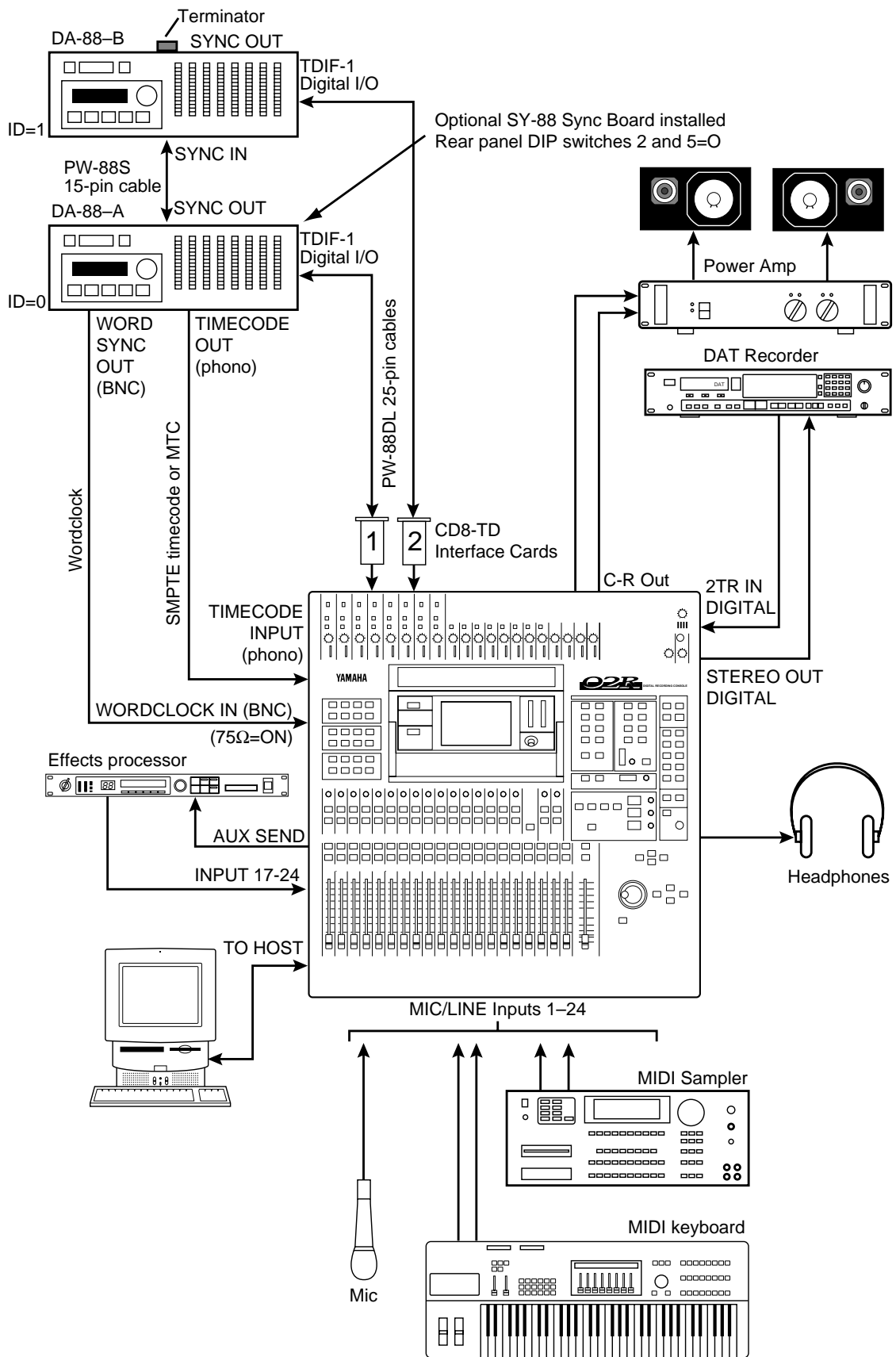

Figure 10 O2R with Two DA-88s

11 02R with Four DA-88s

This application shows how the 02R can be used with four Tascam DA-88s to create a 24-input, 32-track digital recording system, providing 32-track digital mixdown. In addition, the 02R's built-in automation and scene memory systems provide both dynamic and static mix automation referenced to timecode.

Connections

- The Tascam (CD8-TD) cards must be screwed securely in place. Do not leave the screws out after installation as the cards will not be grounded correctly.
- DA-88-A is connected to Slot **1** of the 02R and the tape inputs correspond to tracks one through eight (Tape In 1-8). DA-88-B is connected to Slot **2** of the 02R and the tape inputs correspond to tracks nine through sixteen (Tape In 9-16). DA-88-C is connected to Slot **3** of the 02R and the tape inputs correspond to tracks 17 through 24 (Line In 1-8). DA-88-D is connected to Slot **4** of the 02R and the tape inputs correspond to tracks 25 through 32 (Line In 9-16).
- The optional SY-88 Sync Board is required for DA-88-A. This enables the dedicated timecode track, which can be re-striped at anytime, and provides SMPTE timecode and MTC outputs. A timecode offset can be specified on DA-88-A.

02R Wordclock Setup

On the DIGITAL I/O menu, the wordclock source should be set to W.CLK.

DA-88 Wordclock Setup

DA-88-A works as wordclock master. Wordclock is fed to the 02R using a BNC to BNC cable, and to the other DA-88s using PW-88S 15-pin sync cables. The sampling rate is set when the DA-88 tapes are formatted. This can be either 48 kHz or 44.1 kHz. After formatting, the sampling rate is determined by the formatted tape.

Notes

- The DA-88s must be powered up even when they are not being used. Failure to do so may cause an intermittent pumping noise on the 02R.
 - DA-88-A is set to MACHINE ID 0, DA-88-B to MACHINE ID 1, DA-88-C to MACHINE ID 2, and DA-88-D to MACHINE ID 3. Since DA-88-A works as the Control Master, it should be used for synchronized transport and locate operations.
 - The optional Tascam SY-88 Sync Board must be installed in DA-88-A to use SMPTE timecode and MTC. This is available from Tascam. The other DA-88s do not require SY-88 Sync Boards and their tapes do not have to be striped with timecode. They are synchronized to DA-88-A via the PW-88S 15-pin sync cables.
 - The terminator bundled with a PW-88S sync cable should be connected to the SYNC OUT on DA-88-D to ensure reliable synchronization.
 - The rear panel of the SY-88 Sync Board has a DIP switch labeled MODE. Set DIP switches 2 and 5 to ON (O). Set internal switch 8 on the SY-88 board marked S2 to ON.
 - To use the MTC function, the SY-88 firmware must be version 3.08 or higher.
 - On the Tascam (CD8-TD) card there is a DIP switch that should be set to 16-bit. This is the initial setting, but you should confirm it. This switch is for use with Tascam High-Bit recording applications.
 - Tascam 25-pin digital audio cables PW-88DL (5 m) and PW-88D (1 m), and the 15-pin PW-88S sync cable are available from Tascam.
-

12 Two 02Rs with Four DA-88s

This application shows how two 02Rs can be used with four Tascam DA-88s to create a 48-input, 32-track digital recording system. The 32 digital tape returns and 48 Mic/Line inputs provide up to 80 inputs at mixdown.

The two 02Rs are cascaded together using a 25-pin straight cable and two CD8-CS Cascade cards, which are installed in Slot **3** of each 02R (could be Slot **4**). The cascade connection carries the eight buses, any four of the eight AUX buses, Stereo bus, and Solo bus. This allows both consoles to work together as one large 80-input mixing console. The master section of 02R-B is used for monitoring and two-track operations. The studio monitors and two-track recording equipment are also connected to this 02R.

Connections

- The Tascam (CD8-TD) cards must be screwed securely in place. Do not leave the screws out after installation as the cards will not be grounded correctly.
- DA-88-A is connected to Slot **1** of 02R-A and the tape inputs correspond to tracks one through eight (Tape In 1-8). DA-88-B is connected to Slot **2** of 02R-A and the tape inputs correspond to tracks nine through sixteen (Tape In 9-16). DA-88-C is connected to Slot **1** of 02R-B and the tape inputs correspond to tracks 17 through 24 (Tape In 1-8). DA-88-D is connected to Slot **2** of 02R-B and the tape inputs correspond to tracks 25 through 32 (Tape In 9-16). PW-88DL cables are available from Tascam.
- The optional SY-88 Sync Board is required for DA-88-A. This enables the dedicated timecode track, which can be re-striped at anytime, and provides SMPTE timecode and MTC outputs. A timecode offset can be specified on DA-88-A.

02R Wordclock Setup

On the DIGITAL I/O menu, the wordclock source should be set to W.CLK.

DA-88 Wordclock Setup

DA-88-A works as wordclock master. Wordclock is fed to the 02R using a BNC to BNC cable, and to the other DA-88s using PW-88S 15-pin sync cables, available from Tascam. The sampling rate is set when the DA-88 tapes are formatted. This can be either 48 kHz or 44.1 kHz. After formatting, the sampling rate is determined by the formatted tape.

Notes

- The DA-88s must be powered up even when they are not being used. Failure to do so may cause an intermittent pumping noise on the 02R.
 - DA-88-A is set to MACHINE ID to 0, DA-88-B to MACHINE ID to 1, DA-88-C to MACHINE ID 2, and DA-88-D to MACHINE ID 3. Since DA-88-A works as the Control Master, it should be used for synchronized transport and locate operations.
 - The optional Tascam SY-88 Sync Board must be installed in DA-88-A to use SMPTE timecode and MTC. This is available from Tascam. The other DA-88s do not require SY-88 Sync Boards and their tapes do not have to be striped with timecode. They are synchronized to DA-88-A via the PW-88S 15-pin sync cables.
 - The terminator bundled with a PW-88S sync cable should be connected to the SYNC OUT on DA-88-D to ensure reliable synchronization.
 - The rear panel of the SY-88 Sync Board has a DIP switch labeled MODE. Set DIP switches 2 and 5 to ON (O). Set internal switch 8 on the SY-88 board marked S2 to ON.
 - To use the MTC function, the SY-88 firmware must be version 3.08 or higher.
-

- On the Tascam (CD8-TD) card there is a DIP switch that should be set to 16-bit. This is the initial setting, but you should confirm it. This switch is for use with Tascam High-Bit recording applications.
- The rear of the Cascade (CD8-CS) card has an IN/OUT switch. For 02R-A this must be set to OUT. On 02R-B it must be set to IN.
- The optional CD8-CS kit contains two CD8-CS cards and one 25-pin straight cable.

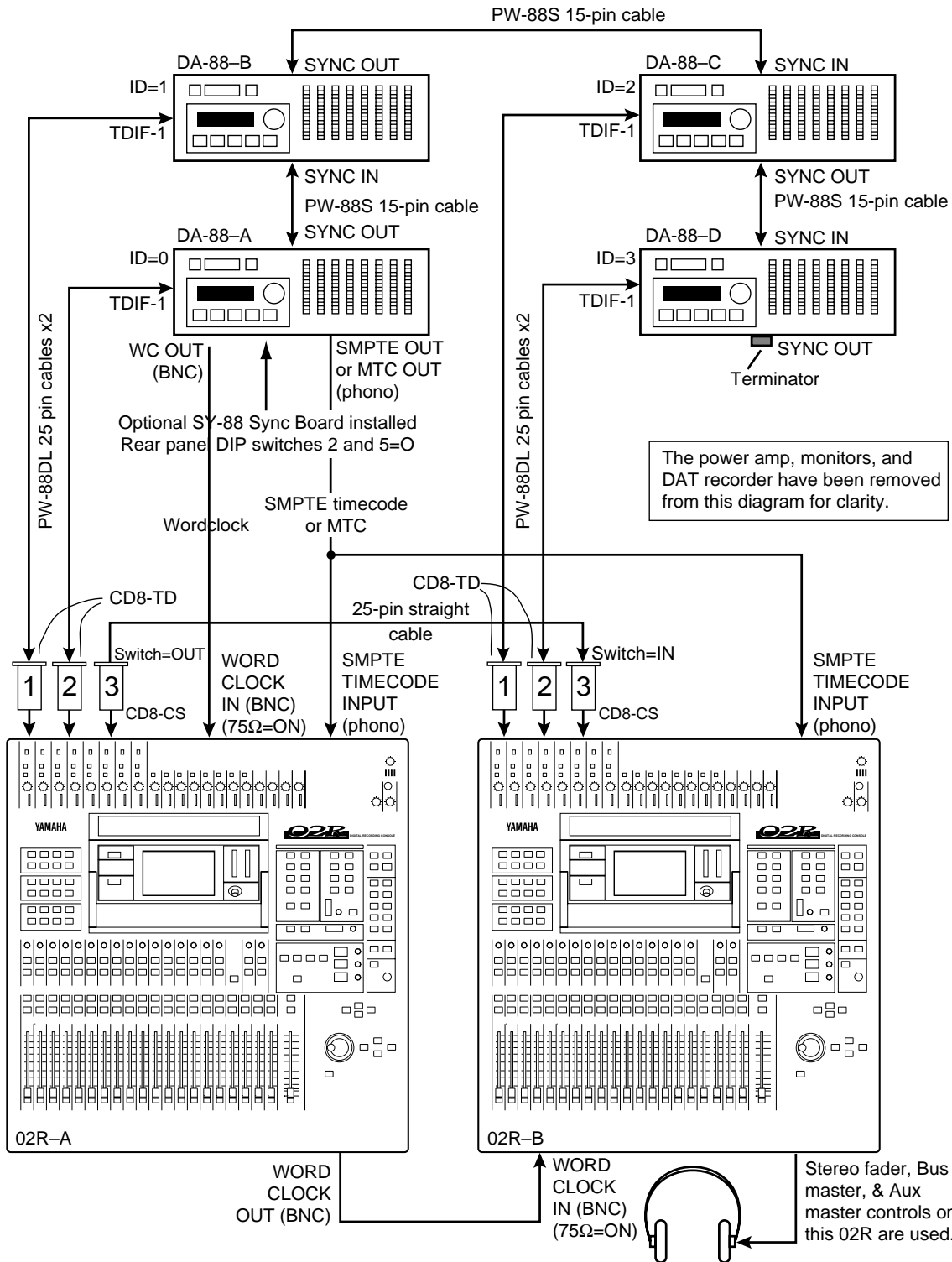

Figure 12 Two 02Rs with Four DA-88s

13 02R with Akai DR8 Hard Disk Recorder

This application shows how the 02R can be used with an Akai DR8 Hard Disk Recorder to create a 24-input, 8-track digital recording system. The eight digital tape returns and 24 Mic/Line inputs provide up to 32 inputs at mixdown. In addition, the 02R's built-in automation and scene memory systems provide both dynamic and static mix automation referenced to timecode.

Connections

- The ADAT (CD8-AT) card must be screwed securely in place. Do not leave the screws out after installation as the cards will not be grounded correctly.
- The DR8 is fitted with an optional ADAT (IB-804A) interface card. For MTC operation, the DR8 requires an optional MIDI (IB803M) interface card. For SMPTE operation, an optional SMPTE (IB802T) interface card.
- The Digital In/Out connectors on the 02R and DR8 are connected together using Optical Cables.
- The DR8 is connected to Slot **1** of the 02R. These tape inputs correspond to tracks one through eight.

02R Wordclock Setup

The 02R works as wordclock slave. An ADAT (CD8-AT) card is installed in Slot **1**, so any pair of the tape inputs from 1 to 8 can be selected as the wordclock source on the DIGITAL I/O menu.

DR8 Wordclock Setup

The DR8 works as wordclock master.

Notes

- When a track is armed for recording, the DR8 will normally try to take its wordclock source from that track's input. To prevent this, in the Digi submenu set Auto Sync to Off. Note that the Auto Sync setting is not memorized when the DR8 is turned off, although it can be stored as part of a project.
-

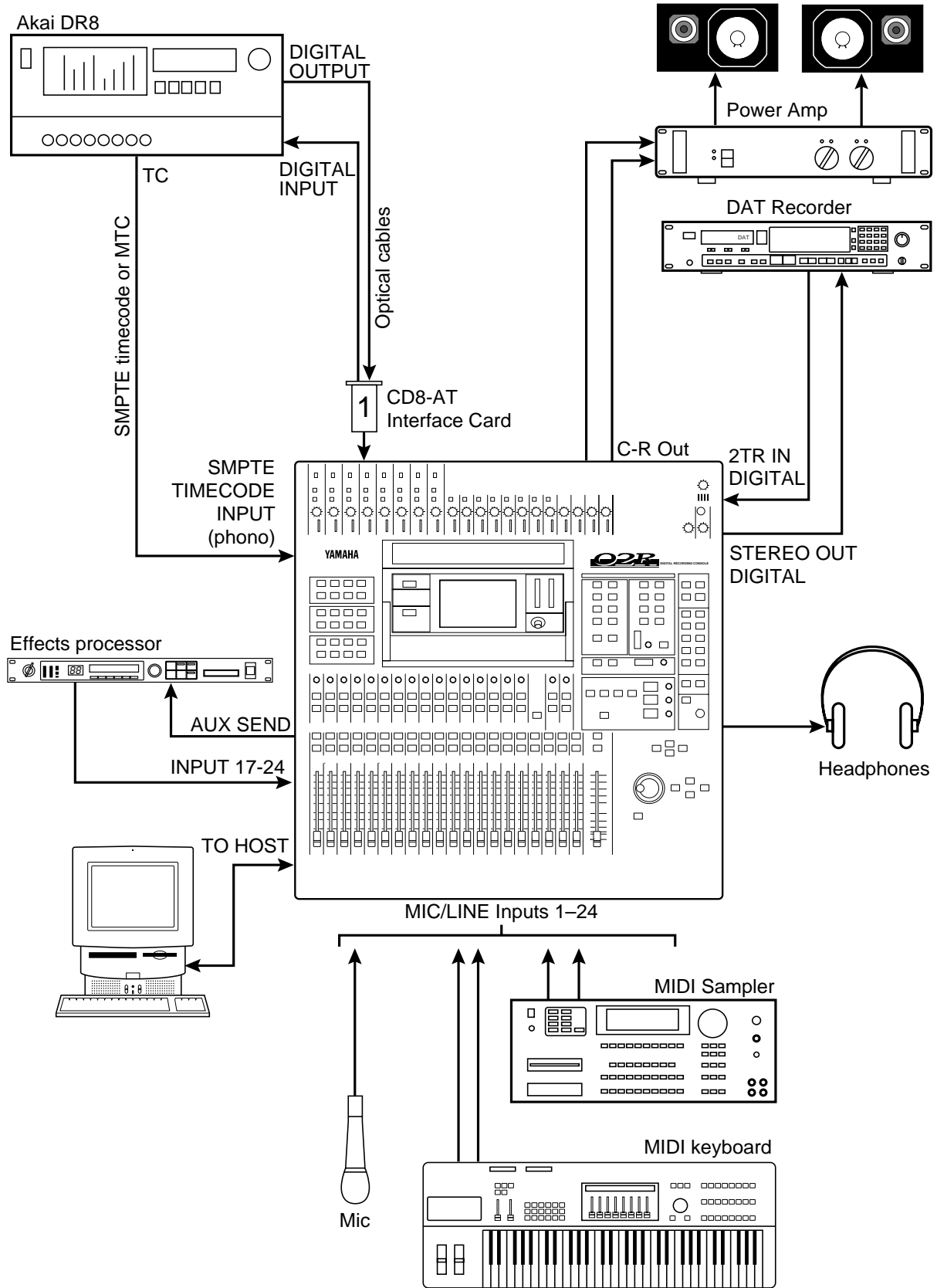

Figure 13 O2R with Akai DR8 Hard Disk Recorder

14 02R with Akai DR16 Hard Disk Recorder

This application shows how the 02R can be used with an Akai DR16 Hard Disk Recorder to create a 24-input, 16-track digital recording system. The 16 digital tape returns and 24 Mic/Line inputs provide up to 40 inputs at mixdown. In addition, the 02R's built-in automation and scene memory systems provide both dynamic and static mix automation referenced to timecode.

The DR16 is a 16-track hard disk recorder featuring 8-track recording and 16-track playback. The ADAT (IB804AEX) interface card provides eight digital inputs and 16 digital outputs.

Connections

- The ADAT (CD8-AT) cards must be screwed securely in place. Do not leave the screws out after installation as the cards will not be grounded correctly.
- The DR16 is fitted with the following options: ADAT (IB804AEX) interface card and MIDI (IB803M) interface card.
- The Digital In/Out connectors on the 02R and DR16 are connected together using Optical Cables.
- The DR16 digital output connected to Slot **1** of the 02R corresponds to tracks one through eight, while the DR16 digital output connected to Slot **2** corresponds to tracks nine through sixteen.

02R Wordclock Setup

The 02R works as wordclock slave. With ADAT (CD8-AT) cards installed in Slot **1** and Slot **2**, any pair of the first 16 tape inputs can be selected as the wordclock source on the DIGITAL I/O menu.

DR16 Wordclock Setup

The DR16 works as wordclock master.

Notes

- When a track is armed for recording, the DR16 will normally try to take its wordclock source from that track's input. To prevent this, in the Digi submenu set Auto Sync to Off. Note that the Auto Sync setting is not memorized when the DR16 is turned off, although it can be stored as part of a project.
-

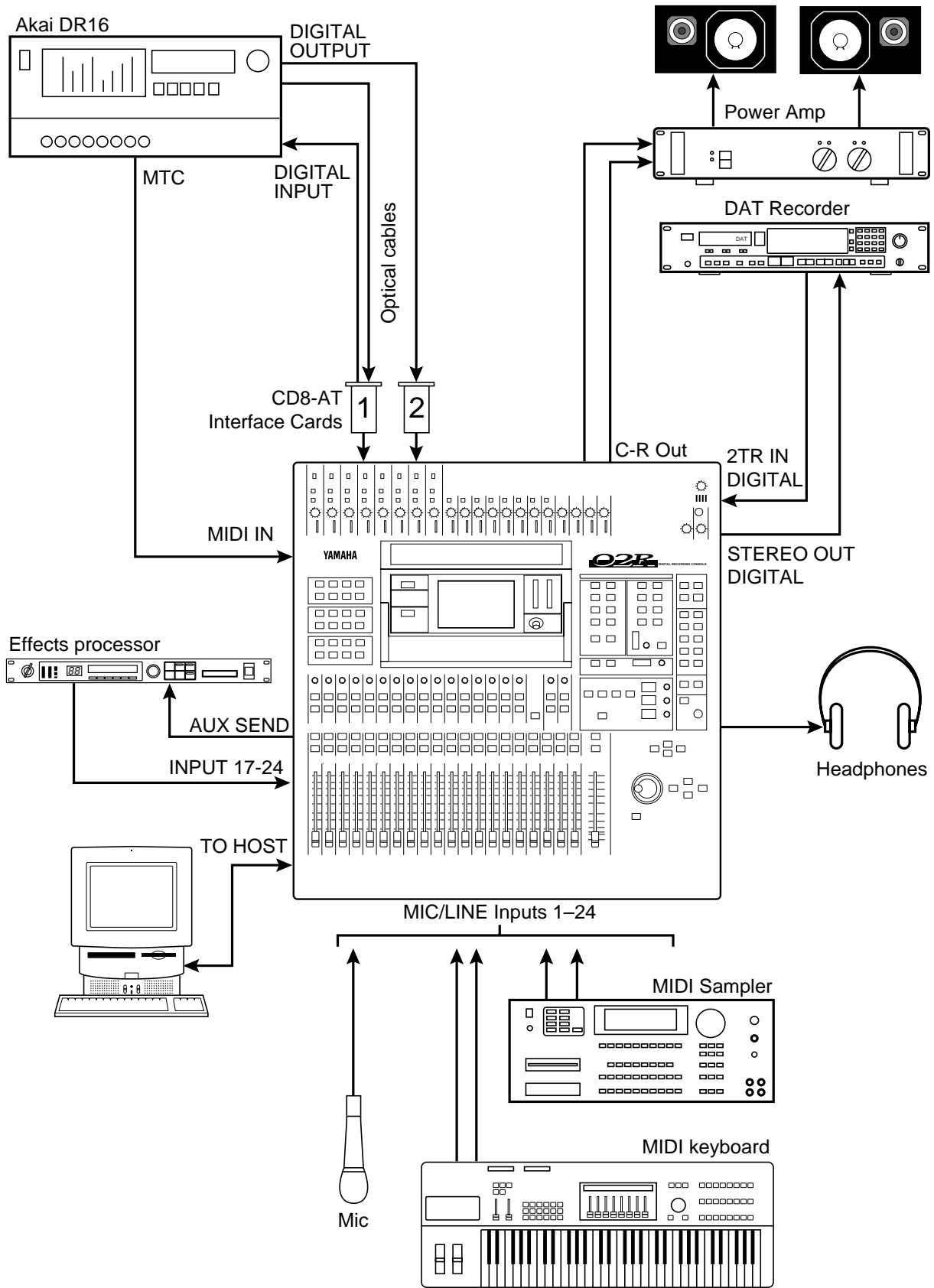

Figure 14 O2R with Akai DR16 Hard Disk Recorder

15 02R with Analog 16-Track Multitrack Recorder

This application shows how the 02R can be used with a 16-track analog multitrack recorder to create a 24-input, 16-track recording system. Track 16 of the multitrack recorder has been stripped with SMPTE timecode. This is fed to the 02R's SMPTE TIMECODE input.

The 16 tape returns and 24 Mic/Line inputs provide up to 32 inputs at mixdown. In addition, the 02R's built-in automation and scene memory systems provide both dynamic and static mix automation referenced to timecode.

Connections

- The AD/DA (CD8-AD) cards must be screwed securely in place. Do not leave the screws out after installation as the cards will not be grounded correctly.

02R Wordclock Setup

02R works as wordclock master.

Notes

- Each AD/DA (CD8-AD) card has eight inputs and eight outputs (16 1/4" phone jacks). It also features a +4 dB/-10 dB level switch. This should be set to match the operating level of the multitrack recorder.
- The AD/DA (CD8-AD) cards are Double size cards and take up two slots. So with AD/DA cards in slots **1** and **2**, slots **3** and **4** cannot be used for other cards.

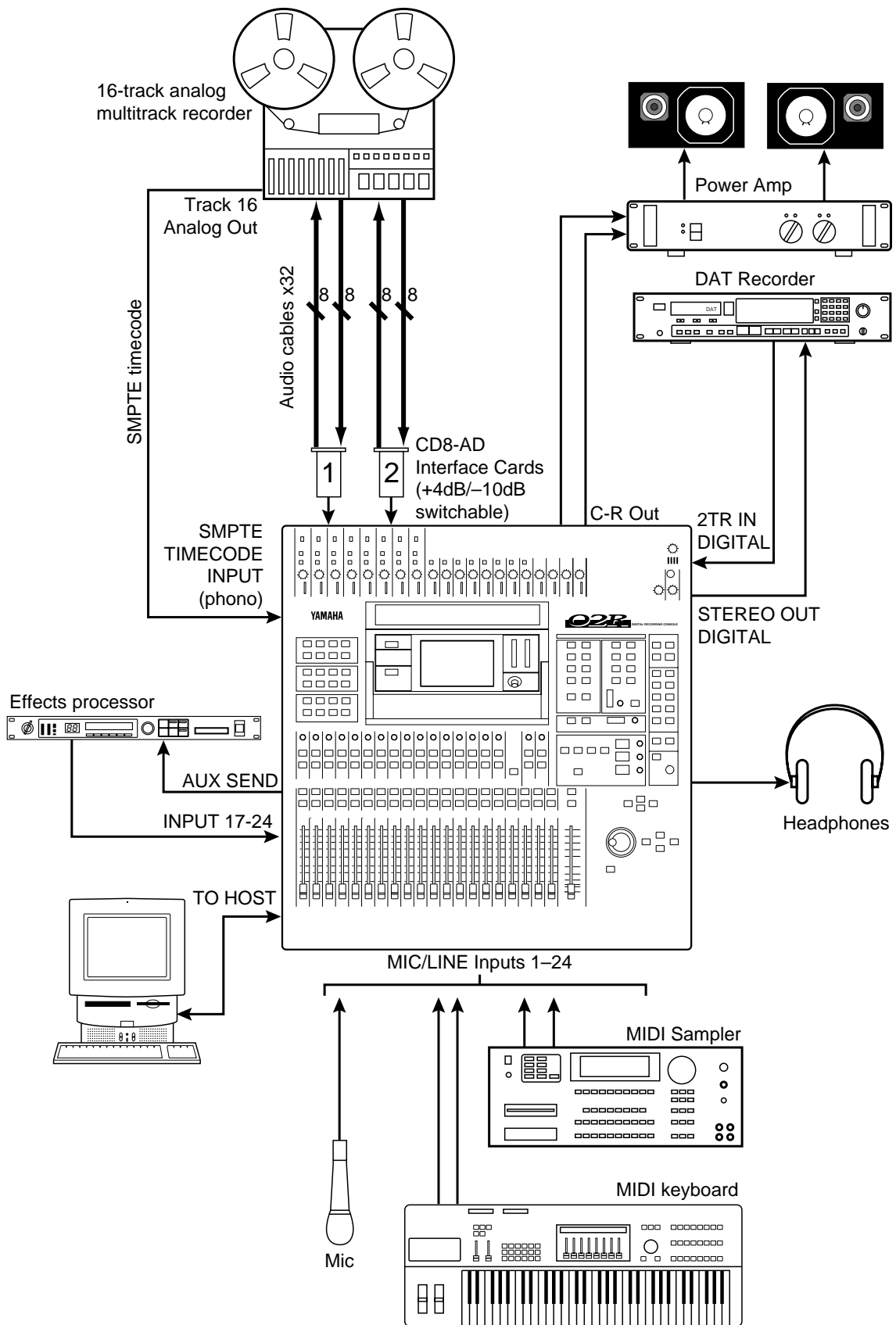

Figure 15 O2R with Analog 16-Track Multitrack Recorder

16 02R with Video Machine, ADAT, & BRC

This application shows how the 02R can be used with a video machine, ADAT, and BRC for audio post-production and audio sweetening, with 02R automation. Using only the SMPTE timecode from the video machine, the BRC can generate both timecode (SMPTE or MTC) and wordclock for the ADAT and 02R. A timecode offset can be specified on the BRC.

Connections

- The ADAT (CD8-AT) card must be screwed securely in place. Do not leave the screws out after installation as the cards will not be grounded correctly.
- The Digital In/Out connectors on the 02R and ADAT are connected together using Optical Cables. Press the **DIGITAL IN** button on the ADAT to use the DIGITAL IN.
- The ADAT's eight tracks connect to 02R slot **1**, tape inputs one through eight.
- The Alesis BRC Master Remote Control can control up to 16 ADATs (i.e. 128 tracks).
- A 9-pin Sync cable for connecting the ADAT and BRC is available from Alesis.
- The 75 ohm wordclock termination switch on the back of the 02R is set to ON.

02R Wordclock Setup

On the DIGITAL I/O menu, the wordclock source should be set to W.CLK.

ADAT & BRC Wordclock Setup

The BRC works as wordclock master and the ADAT locks to it automatically via the 9-pin sync cable. The sampling rate can be set to either 48 kHz or 44.1 kHz.

Notes

- The ADAT must be powered up before the BRC, because when the BRC is powered up it checks how many ADATs are connected, allocates them device numbers, and automatically sets the system wordclock.
 - On the BRC, set the Clock Source to Internal. Setting it to SMPTE may cause noise.
 - To generate timecode on the BRC, press the GEN SYNC button.
 - On the BRC, set the DIGITAL I/O button to OFF. This function is for direct ping-pong between multiple ADATs. If this is turned ON while connected to an 02R, bus assignments will produce unexpected results. Press the DIGITAL IN button on the ADAT to use the DIGITAL INPUT.
-

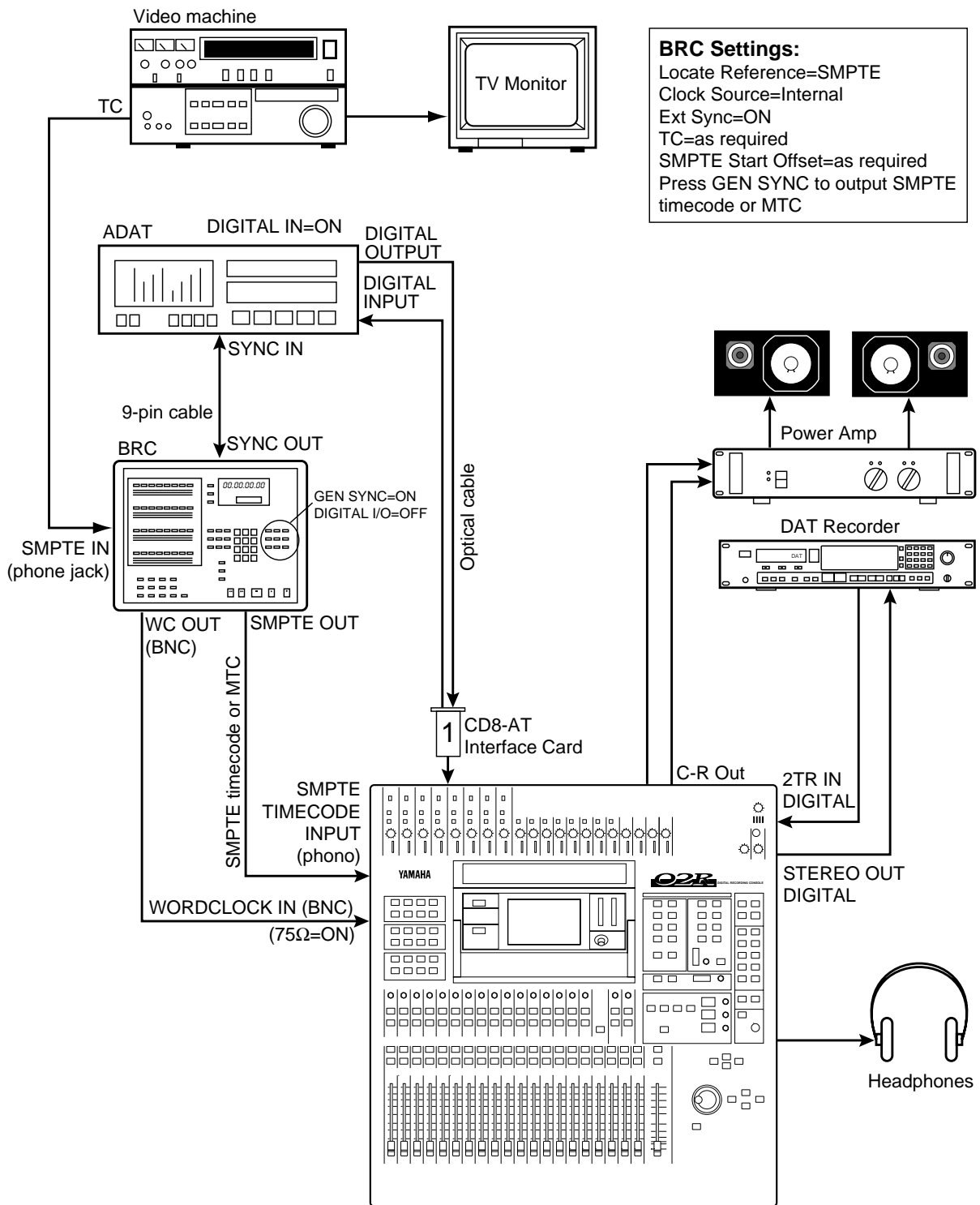

Figure 16 02R with Video Machine, ADAT, & BRC

17 02R with Video Machine, ADAT, & AI-2

This application shows how the 02R can be used with a video machine, ADAT, and AI-2 Multipurpose Audio/Video Synchronization Interface for audio post-production and audio sweetening, with 02R automation. Using only the SMPTE timecode from the video machine, the AI-2 can generate both timecode (SMPTE or MTC) and wordclock for the ADAT and 02R. A timecode offset can be specified on the AI-2.

Connections

- The ADAT (CD8-AT) card must be screwed securely in place. Do not leave the screws out after installation as the cards will not be grounded correctly.
- The Digital In/Out connectors on the 02R and ADAT are connected together using Optical Cables. Press the **DIGITAL IN** button on the ADAT to use the DIGITAL IN.
- The ADAT's eight tracks connect to 02R slot **1**, tape inputs one through eight.
- A 9-pin Sync cable for connecting the ADAT and AI-2 is available from Alesis.
- The 75 ohm wordclock termination switch on the back of the 02R is set to ON.

02R Wordclock Setup

On the DIGITAL I/O menu, the wordclock source should be set to W.CLK.

ADAT & AI-2 Wordclock Setup

The AI-2 works as wordclock master and the ADAT locks to it automatically via the 9-pin sync cable. The AI-2 sampling rate should be set to match that of the ADAT tape.

Notes

- On the AI-2, set the ONLINE Key for chasing.
-

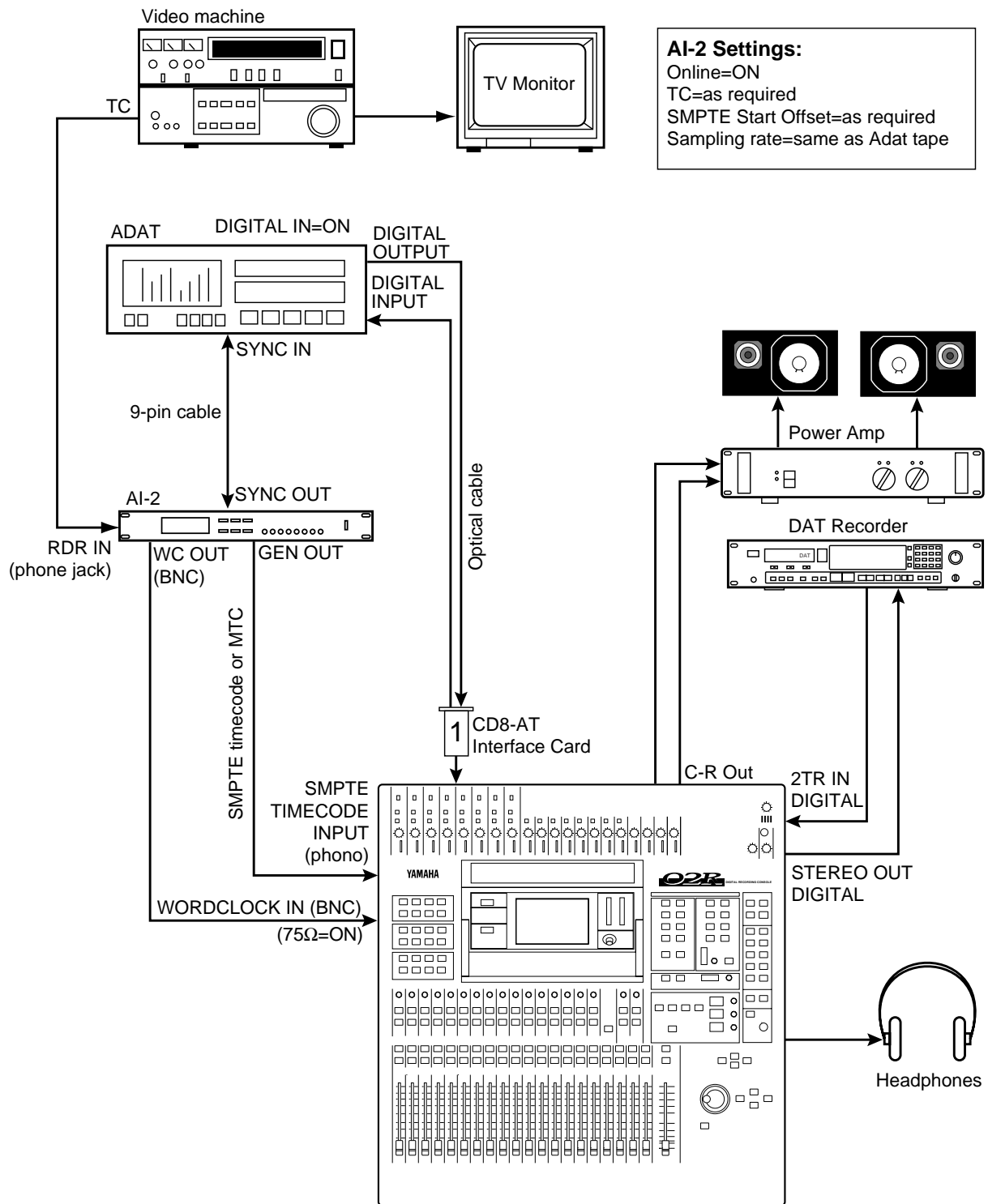

Figure 17 O2R with Video Machine, ADAT, & AI-2

18 02R with Video Machine & DA-88

This application shows how the 02R can be used with a video machine and DA-88 for audio post-production and audio sweetening, with 02R automation. Using only the SMPTE timecode from the video machine, the DA-88 can generate timecode (SMPTE or MTC) for the 02R. A timecode offset can be specified on the DA-88.

Connections

- The Tascam (CD8-TD) card must be screwed securely in place. Do not leave the screws out after installation as the card will not be grounded correctly.
- The Tascam digital audio cable (PW-88DL) carries the eight tape sends and eight tape returns.
- The DA-88 is connected to Slot **1** of the 02R. These tape inputs correspond to tracks one through eight.
- The optional SY-88 Sync Board is required. The DA-88 has a dedicated timecode track and can output SMPTE timecode or MTC. In addition, a timecode offset can be specified on the DA-88, so the 02R automix start time can be adjusted. The DA-88 also has the ability to re-stripe the timecode track.
- The video house sync is connected to the Video In BNC connection on the DA-88.

02R Wordclock Setup

The 02R works as a wordclock slave. A Tascam (CD8-TD) card is installed in Slot **1**, so any one of the first 8 tape inputs can be selected as the wordclock source on the DIGITAL I/O menu.

DA-88 Wordclock Setup

The DA-88 generates a wordclock signal referenced to the Video In signal (VIDEO). The sampling rate is set when the DA-88 tape is formatted. This can be either 48 kHz or 44.1 kHz. After formatting, the sampling rate is determined by the formatted tape.

Notes

- The DA-88 must be powered up even when it is not being used. Failure to do so may cause an intermittent pumping noise on the 02R.
 - On the DA-88 rear panel, set the MACHINE ID to 0.
 - The optional Tascam SY-88 Sync Board must be installed to use SMPTE timecode and MTC. This is available from Tascam.
 - The rear panel of the SY-88 Sync Board has a DIP switch labeled MODE. Set DIP switches 2 and 5 to ON (0). Set internal switch 8 on the SY-88 board marked S2 to ON.
 - To use the MTC function, the SY-88 firmware must be version 3.08 or higher.
 - On the Tascam (CD8-TD) card there is a DIP switch that should be set to 16-bit. This is the initial setting, but you should confirm it. This switch is for use with Tascam High-Bit recording applications.
 - Tascam 25-pin digital audio cables PW-88DL (5 m) and PW-88D (1 m) are available from Tascam.
-

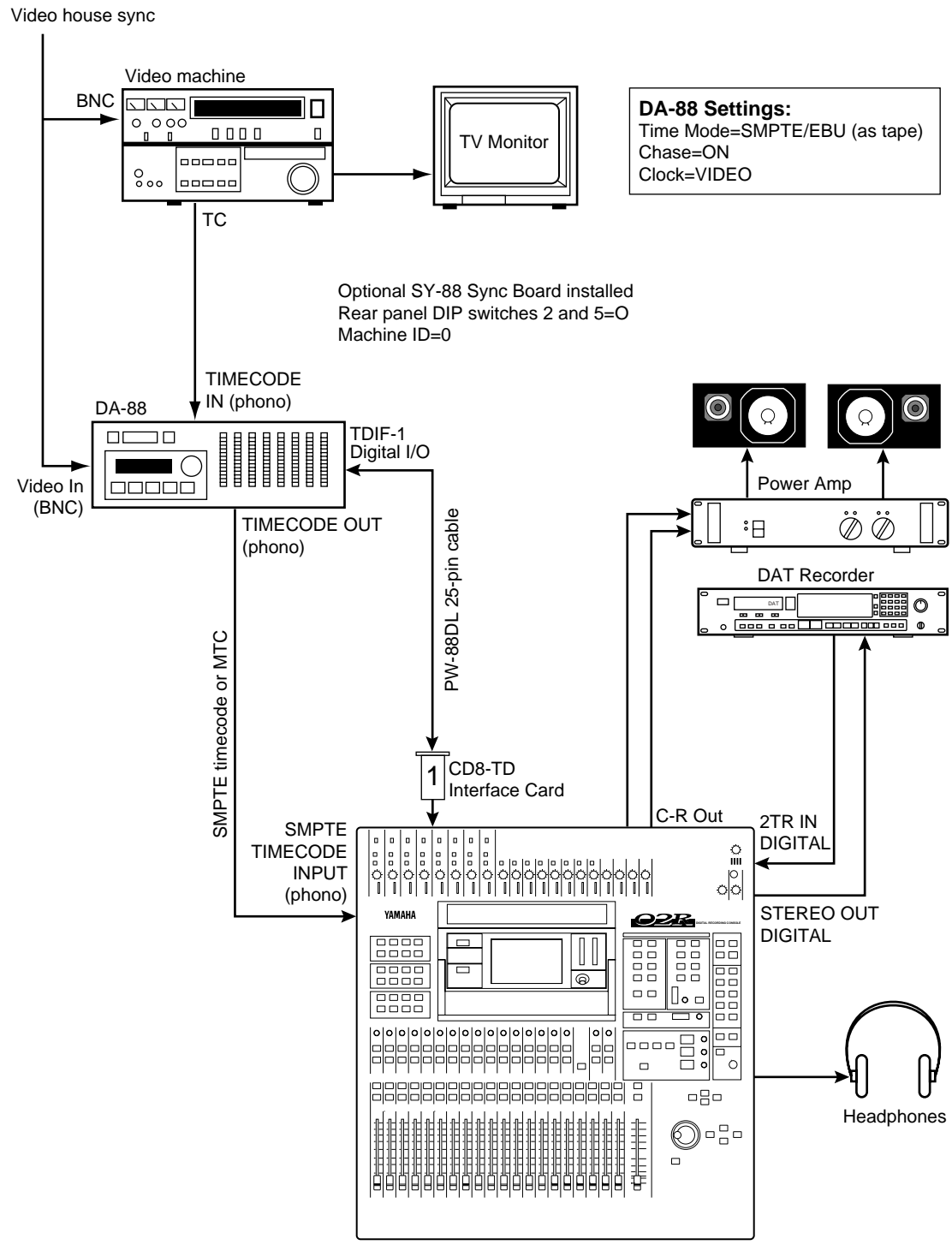

Figure 18 O2R with Video Machine & DA-88

19 02R with Two Fostex D-90s

This application shows how the 02R can be used with two Fostex D-90 hard disk recorders to create a 24-input, 16-track digital recording system. The 16 digital tape returns and 24 Mic/Line inputs provide up to 40 inputs at mixdown. In addition, the 02R's built-in automation and scene memory systems provide both dynamic and static mix automation referenced to MIDI timecode.

The Fostex D-90 hard disk recorder features ADAT I/O as standard. For multiple operation, no special cables are required, and only the MIDI IN/OUT ports need to be connected for MTC-referenced synchronization.

Connections

- The ADAT (CD8-AT) cards must be screwed securely in place. Do not leave the screws out after installation as the cards will not be grounded correctly.
- The Digital In/Out connectors on the 02R and D-90s are connected together using Optical Cables.
- D-90-A is connected to Slot **1** of the 02R and the tape inputs correspond to tracks one through eight.
- D-90-B is connected to Slot **2** of the 02R and the tape inputs correspond to tracks nine through sixteen.

02R Wordclock Setup

The 02R works as wordclock master.

D-90 Wordclock Setup

Each D-90 should be configured as a wordclock slave, with the ADAT interface as the source.

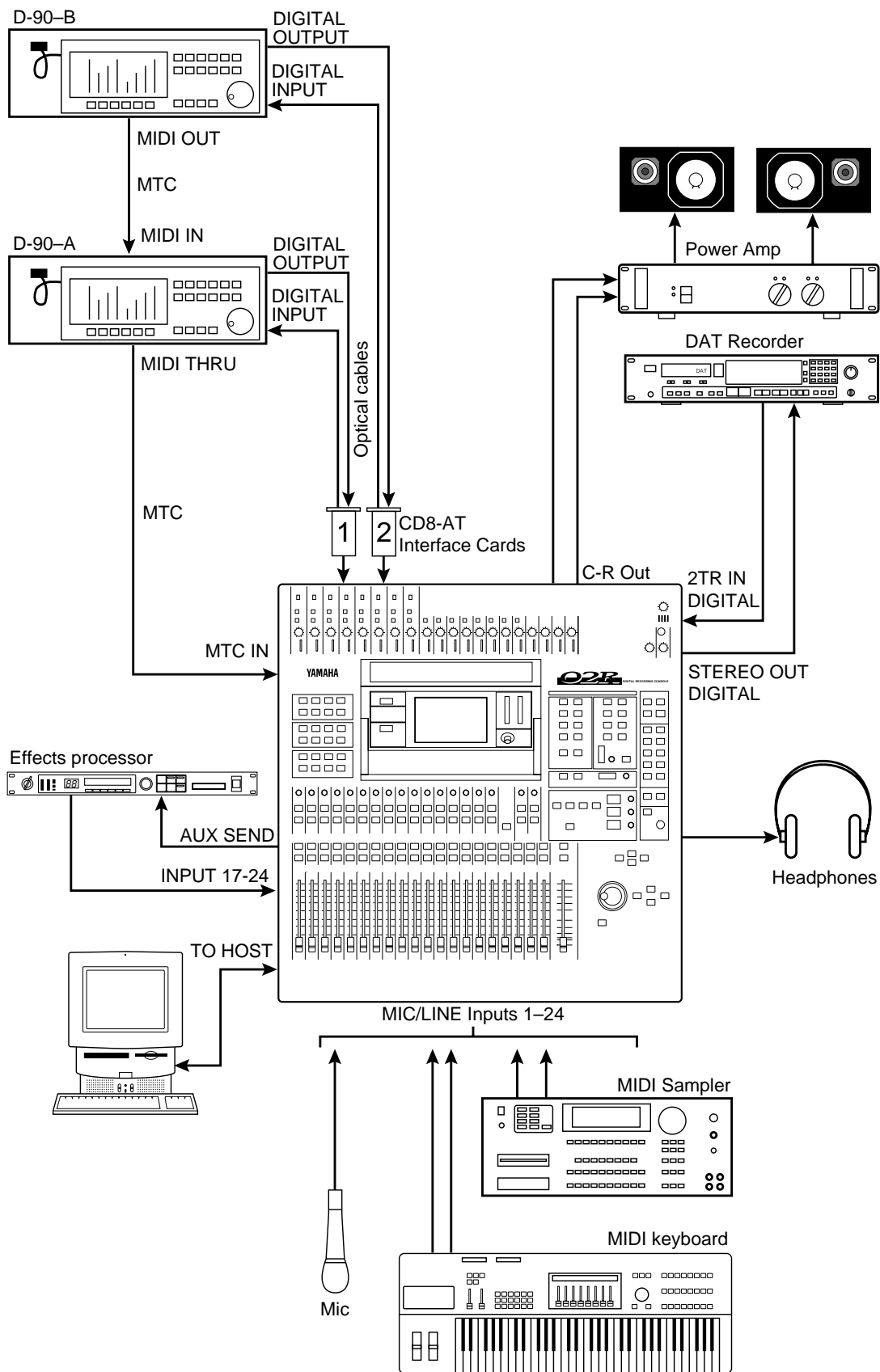

Figure 19 O2R with Two Fostex D-90s

20 02R with Pro Tools for Music Recording

This application shows how the 02R can be used with a Pro Tools system. The eight digital tape returns and 24 Mic/Line inputs provide up to 40 inputs at mixdown. In addition, the 02R's built-in automation and scene memory systems provide both dynamic and static mix automation referenced to MIDI timecode.

A Digidesign 888 I/O Audio Interface connects the 02R to the Pro Tools system, with a special 50-pin Pro Tools cable between the computer card and 888. The 25-pin connector on the CD8-AE-S card connects to a patchbox, which provides eight AES/EBU inputs (four XLRs) and eight AES/EBU outputs (four XLRs).

Pro Tools can be controlled remotely from the 02R V2 using the Pro Tools template of the MIDI Remote function. The 02R's built-in automation is referenced to MTC coming from the Pro Tools system. A MOTU MIDI Timepiece (or Opcode Studio 4) is used as a MIDI interface and connects to the computer's Modem port.

Connections

- The AES/EBU (CD8-AE-S) card must be screwed securely in place. Do not leave the screws out after installation as the card will not be grounded correctly.
- The Digital In/Out connectors on the 02R and patchbox are connected together using a 25-pin D-sub cable.
- The patchbox is connected to the 888 I/O Audio Interface using AES/EBU-compatible XLR cables.
- The 888 I/O Audio Interface connects to the audio card using a special 50-pin Pro Tools cable.
- The Pro Tools system is connected to Slot **1** of the 02R and the tape inputs correspond to tracks one through eight.

02R Wordclock Setup

The 02R works as a wordclock slave. On the DIGITAL I/O menu, set the wordclock source to TAPE 1/2 (i.e., AES/EBU 1/2).

Pro Tools Wordclock Setup

The Pro Tools system should be configured as wordclock master.

Note

- The D-sub <-> XLR box (or D-sub to XLR break-out cable) is not available from Yamaha, and should be custom made.
-

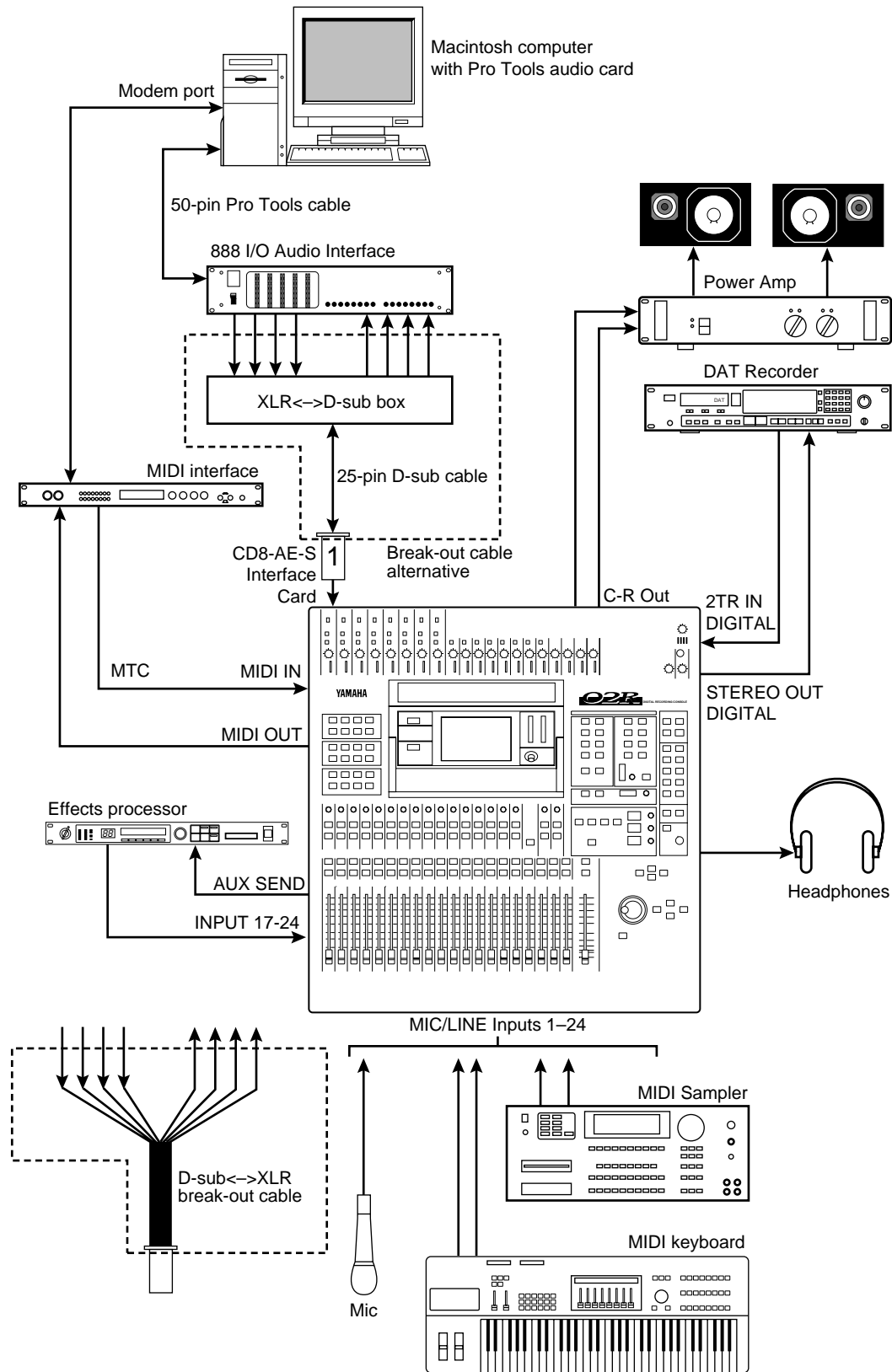

Figure 20 02R with Pro Tools for Music Recording

21 02R with Pro Tools for Video Post

This application shows how the 02R can be used with a video machine and Pro Tools system for audio post-production and audio sweetening. The 16 digital tape returns and 24 Mic/Line inputs provide up to 40 inputs. In addition, the 02R's built-in automation and scene memory systems provide both dynamic and static mix automation referenced to SMPTE or MIDI timecode.

Two Digidesign 888 I/O Audio Interfaces connect the 02R to the Pro Tools system, with special 50-pin Pro Tools cables between the computer cards and each 888. Two custom-made D-sub to XLR break-out cables are used to connect the 25-pin connectors on the CD8-AE-S cards to the 888s.

Pro Tools can be controlled remotely from the 02R V2 using the Pro Tools template of the MIDI Remote function.

Connections

- The AES/EBU (CD8-AE-S) cards must be screwed securely in place. Do not leave the screws out after installation as the cards will not be grounded correctly.
- The Digital In/Out connectors on the 02Rs and 888s are connected together using custom-made D-sub to XLR cables.
- The Pro Tools system is connected to 02R Slot **1** (tape inputs 1 through 8) and Slot **2** (tape inputs 9 through 16).

02R Wordclock Setup

The 02R works as a wordclock slave. On the DIGITAL I/O menu, set the wordclock source to TAPE 1/2 (i.e., AES/EBU 1/2).

Pro Tools Wordclock Setup

The Pro Tools system should be configured as wordclock master.

Notes

- The D-sub <-> XLR break-out cable is not available from Yamaha, and should be custom made.
 - The slave clock (Super Clock) signal connected between Digidesign products is an exclusive clock, with a sampling rate of $F_s \times 256$.
-

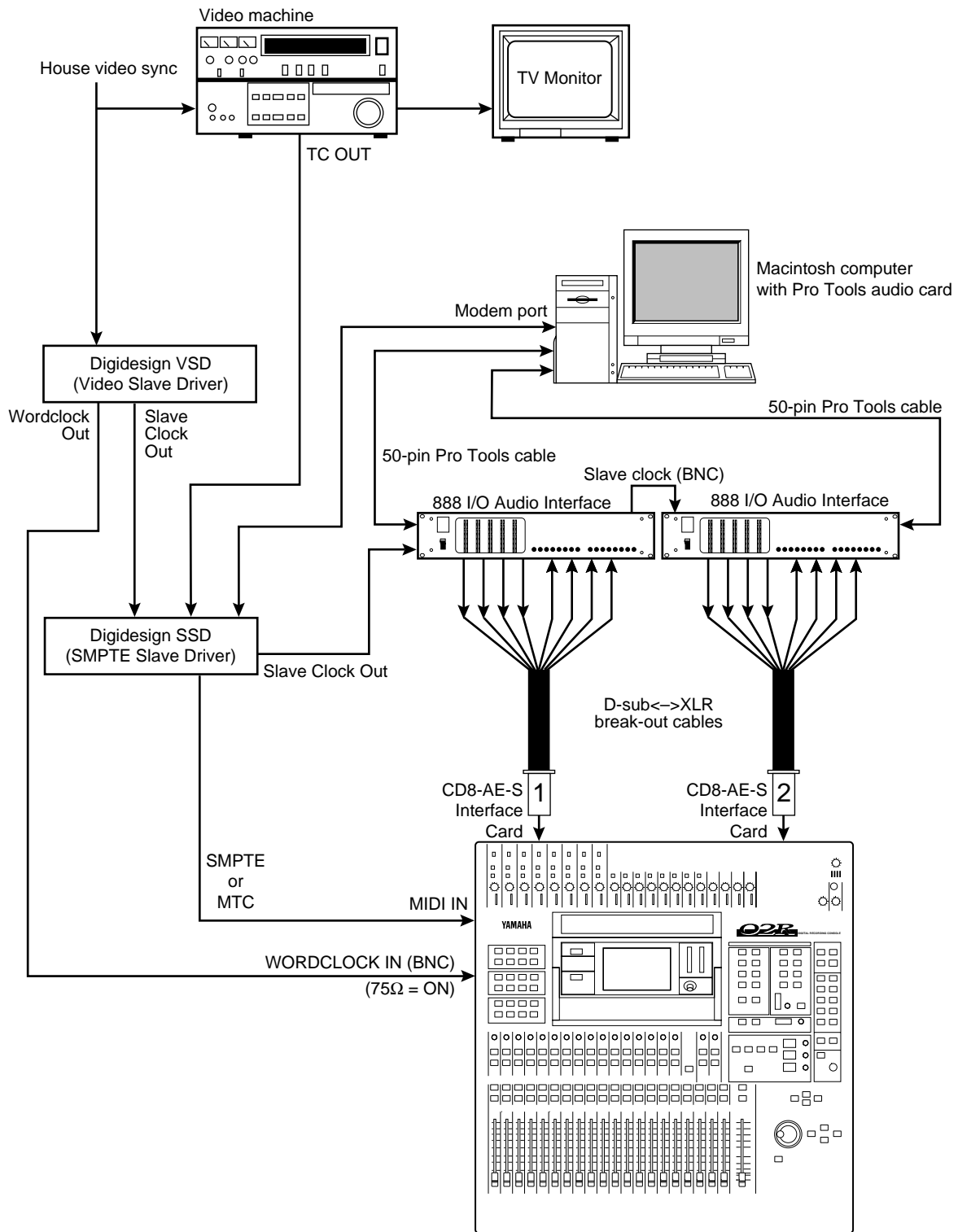

Figure 21 02R with Pro Tools for Video Post

Trademarks

ADAT and Alesis are registered trademarks of Alesis Corporation.

ADAT MultiChannel Optical Digital Interface is a trademark of Alesis Corporation.

Akai is a trademark of Akai Electric Corporation.

Digidesign is a trademark of Digidesign or Avid Technology, Inc.

Fostex is a trademark of Fostex Corporation.

Mark of the Unicorn is a trademark of Mark of the Unicorn, Inc.

Opcode is a trademark of Opcode Systems, Inc.

Pro Tools is a registered trademark of Digidesign or Avid Technology, Inc.

TASCAM and TEAC are registered trademarks of TEAC Corporation.

Tascam Digital Interface (TDIF-1) is a trademark of TEAC Corporation.

JL Cooper is a trademark of JL Cooper Electronics.

All other trademarks and registered trademarks are the property of their respective holders.

Copyright

© 1997 Yamaha Corporation. All rights reserved.

No part of this *Applications Guide* may be reproduced or distributed in any form or by any means without the prior written authorization of Yamaha Corporation.



Printed in Japan

YAMAHA CORPORATION
Pro Audio & Digital Musical Instrument Division
P.O. Box 3, Hamamatsu, 430-8651, Japan