



# YAMAHA

# O1V

## DIGITAL MIXING CONSOLE

# Owner's Manual



## FCC INFORMATION (U.S.A.)

### 1. IMPORTANT NOTICE: DO NOT MODIFY THIS UNIT!

This product, when installed as indicated in the instructions contained in this manual, meets FCC requirements. Modifications not expressly approved by Yamaha may void your authority, granted by the FCC, to use the product.

### 2. IMPORTANT: When connecting this product to accessories and/or another product use only high quality shielded cables. Cable/s supplied with this product MUST be used. Follow all installation instructions. Failure to follow instructions could void your FCC authorization to use this product in the USA.

### 3. NOTE: This product has been tested and found to comply with the requirements listed in FCC Regulations, Part 15 for Class "B" digital devices. Compliance with these requirements provides a reasonable level of assurance that your use of this product in a residential environment will not result in harmful interference with other electronic devices. This equipment generates/uses radio frequencies and, if not installed and used according to the instructions found in the users manual, may cause interference harmful to the operation of other electronic devices. Compliance with FCC regulations does not guarantee that interference will not occur in all installations. If this product is found to be the source of interference, which can be determined by turning the unit "OFF" and "ON", please try to eliminate the problem by using one of the following measures:

Relocate either this product or the device that is being affected by the interference.

Utilize power outlets that are on different branch (circuit breaker or fuse) circuits or install AC line filter/s.

In the case of radio or TV interference, relocate/reorient the antenna. If the antenna lead-in is 300 ohm ribbon lead, change the lead-in to coaxial type cable.

If these corrective measures do not produce satisfactory results, please contact the local retailer authorized to distribute this type of product. If you can not locate the appropriate retailer, please contact Yamaha Corporation of America, Electronic Service Division, 6600 Orangethorpe Ave, Buena Park, CA 90620

\* This applies only to products distributed by YAMAHA CORPORATION OF AMERICA.

## IMPORTANT NOTICE FOR THE UNITED KINGDOM

### Connecting the Plug and Cord

#### WARNING: THIS APPARATUS MUST BE EARTHED

IMPORTANT: The wires in this mains lead are coloured in accordance with the following code:

GREEN-AND-YELLOW : EARTH  
BLUE : NEUTRAL  
BROWN : LIVE

As the colours of the wires in the mains lead of this apparatus may not correspond with the coloured markings identifying the terminals in your plug, proceed as follows:

The wire which is coloured GREEN and YELLOW must be connected to the terminal in the plug which is marked by the letter E or by the safety earth symbol or coloured GREEN and YELLOW.

The wire which is coloured BLUE must be connected to the terminal which is marked with the letter N or coloured BLACK.

The wire which is coloured BROWN must be connected to the terminal which is marked with the letter L or coloured RED.

\* This applies only to products distributed by YAMAHA KEMBLE MUSIC (U.K.) LTD.

## ADVARSEL!

Lithiumbatteri—Eksplodingsfare ved fejlagtig håndtering. Udskiftning må kun ske med batteri af samme fabrikat og type. Levér det brugte batteri tilbage til leverandoren.

## VARNING

Explosionsfara vid felaktigt batteribyte. Använd samma batterityp eller en ekvivalent typ som rekommenderas av apparattillverkaren. Kassera använt batteri enligt fabrikantens instruktion.

## VAROITUS

Paristo voi räjähtää, jos se on virheellisesti asennettu. Vaihda paristo ainoastaan laitevalmistajan suosittelemaan tyyppiin. Hävitä käytetty paristo valmistajan ohjeiden mukaisesti.

## NEDERLAND

- Dit apparaat bevat een lithium batterij voor geheugen back-up.
- Raadpleeg uw leverancier over de verwijdering van de batterij op het moment dat u het apparaat aan het einde van de levensduur afdankt of de volgende Yamaha Service Afdeeling:  
Yamaha Music Nederland Service Afdeeling  
Kanaalweg 18-G, 3526 KL UTRECHT  
Tel. 030-2828425
- Gooi de batterij niet weg, maar lever hem in als KCA.

## THE NETHERLANDS

- This apparatus contains a lithium battery for memory back-up.
- For the removal of the battery at the moment of the disposal at the end of the service life please consult your retailer or Yamaha Service Center as follows:  
Yamaha Music Nederland Service Center  
Address: Kanaalweg 18-G, 3526 KL  
UTRECHT  
Tel: 030-2828425
- Do not throw away the battery. Instead, hand it in as small chemical waste.

---

# Important Information

---

## Read the Following Before Operating the 01V

### Warnings

- Do not locate the 01V in a place subject to excessive heat or in direct sunlight. This could be a fire hazard.
- Do not place the 01V in a place subject to excessive humidity or dust. This could be a fire and electrical shock hazard.
- Connect the 01V power cord only to an AC outlet of the type stated in this *Owner's Manual* or as marked on the 01V. Failure to do so is a fire and electrical shock hazard.
- Do not plug several devices into the same AC outlet. This can overload the AC outlet, and can be a fire and electrical shock hazard. It may also affect the performance of some devices.
- Do not place heavy objects on the power cord. A damaged power cord is a potential fire and electrical shock hazard.
- Do not place a container with liquid or small metal objects on top of this unit. Liquid or metal objects inside this unit are a fire and electrical shock hazard.
- If the power cord is damaged (i.e., cut or a bare wire is exposed), ask your dealer for a replacement. Using the 01V in this condition is a fire and shock hazard.
- Hold the power cord plug when disconnecting from an AC outlet. Never pull the cord. Damaging the power cord in this way is a potential fire and electrical shock hazard.
- Do not place small metal objects on top of the 01V. Metal objects inside the 01V are a fire and electrical shock hazard.
- Do not block the 01V ventilation slots. The 01V has ventilation slots on the top and rear to prevent the internal temperature from rising. Blocked ventilation slots are a fire hazard.
- Do not try to modify the 01V. This could be a fire and electrical shock hazard.
- The 01V operating temperature is between 5°C and 35°C (41°F and 95°F).
- If lightning begins to occur, turn off the power switch of the unit as soon as possible, and unplug the power cable plug from the electrical outlet.
- If there is a possibility of lightning, do not touch the power cable plug if it is still connected. Doing so may be an electrical shock hazard.
- If you notice any abnormality—such as smoke, odor, or noise—turn off the 01V immediately. Remove the power cord from the AC outlet. Confirm that the abnormality is no longer present. Consult your dealer for repair. Using the 01V in this condition is a fire and shock hazard.

### Cautions

- Turn off all audio devices and speakers when connecting to the 01V. Refer to the owner's manual for each device. Use the correct cables and connect as specified.
- If a foreign object or water gets inside the 01V, turn it off immediately. Remove the power cord from the AC outlet. Consult your dealer for repair. Using the 01V in this condition is a fire and electrical shock hazard.

- If you plan not to use the 01V for a long period of time, remove the power cord from the AC outlet. Leaving the 01V connected is a fire hazard.
- Do not use benzene, thinner, cleaning detergent, or a chemical cloth to clean the 01V. Use only a soft, dry cloth.
- The 01V is a heavy piece of equipment. Always grip the underneath, not the side panels, when lifting.

## Interference

01V uses high-frequency digital circuits that may cause interference on radios and televisions placed close to it. If interference does occur, relocate the affected equipment.

## Copyright

© 1998 Yamaha Corporation. All rights reserved.

No part of the 01V software or this *Owner's Manual* may be reproduced or distributed in any form or by any means without the prior written authorization of Yamaha Corporation.

## Trademarks

ADAT MultiChannel Optical Digital Interface is a trademark and ADAT and Alesis are registered trademarks of Alesis Corporation. Macintosh is a registered trademark of Apple Computer, Inc. Pro Tools is a registered trademark of Digidesign or Avid Technology, Inc. Tascam Digital Interface is a trademark and Tascam and TEAC are registered trademarks of TEAC Corporation. Windows is a trademark of Microsoft Corporation.

All other trademarks are the property of their respective holders and are hereby acknowledged.

## Package Contents

The 01V package should contain the following items. Make sure that you have them all.

- 01V Digital Mixing Console
- Owner's Manual

Contact your Yamaha dealer if anything is missing.

# Keep this manual for future reference!

---

# Contents

---

<b>1</b>	<b>Welcome to the 01V</b>	<b>1</b>
	Welcome to the 01V	2
	About this Owner's Manual	2
	01V Installation	2
	01V Features	3
	Key Feature Discussion	4
<b>2</b>	<b>Getting Started</b>	<b>9</b>
	01V System Example	10
	Important Wordclock Information	11
	Connecting the Power Cord	11
	Turning On the 01V	11
	Turning Off the 01V	11
<b>3</b>	<b>Touring the 01V</b>	<b>13</b>
	Top Panel Controls	14
	Inputs & Outputs	20
	Block Diagram	24
<b>4</b>	<b>Getting Around the User Interface</b>	<b>27</b>
	About the User Interface	28
	Display	28
	Display Elements	30
	Cursor Buttons	31
	PARAMETER Wheel	31
	-1/DEC & +1/INC Buttons	31
	ENTER Button	31
	Fader Modes	32
	Title Edit Dialog Box	37
<b>5</b>	<b>Input Channels</b>	<b>39</b>
	Input Channel Overview	40
	Phantom Powering	41
	Pad Switches	41
	Setting Input Channel Gain	41
	Metering Input Channels	41
	Changing the Input Phase	42
	Attenuating Input Channel Signals	43
	Applying EQ to Input Channels	44
	Input Channels Dynamics Processors	44
	Delaying Channel Signals	45
	Muting Input Channels	46
	Setting Input Channel Levels	46
	Panning Input Channels	47
	Routing Input Channels	49
	Monitoring Input Channels	50
	Input Channels & Aux Sends	50

Input Channels & the Omni Outs .....	50
Input Channels & the Option I/O Outs .....	50
Swapping Inputs 1–8 & 17–24 .....	51
Pairing Input Channels .....	52
Grouping Faders .....	55
Grouping Mutes .....	56
Viewing Input Channel Settings .....	57
Copying & Swapping Channel Settings .....	59
Input Channel Block Diagram .....	60
<b>6 EQ .....</b>	<b>61</b>
About the 01V EQ .....	62
Adjusting the EQ .....	63
EQ Specs .....	66
Bypassing the EQ .....	66
Resetting the EQ .....	66
EQ Library .....	67
Preset EQ Program List .....	67
Storing EQ Programs .....	68
Recalling EQ Programs .....	69
Editing EQ Program Titles .....	70
Preset EQ Program Parameters .....	71
<b>7 Solo, Monitors &amp; Meters .....</b>	<b>75</b>
About Monitor & Solo .....	76
Monitor Outputs .....	77
Phones .....	77
Two-track Input (2TR IN) .....	77
Monitor Setup .....	78
Using Monitor .....	78
Monitor Block Diagram .....	79
Solo Setup .....	80
Using Solo .....	81
Solo Block Diagram .....	82
Metering Signal Levels .....	83
Main Stereo Meters .....	84
Peak Hold .....	84
Setting the Metering Point .....	85
Option I/O Meters (input channels 17–24) .....	85
Effects Send Meters .....	86
<b>8 Stereo Output .....</b>	<b>87</b>
About the Stereo Output .....	88
Analog Stereo Output .....	88
2TR Out & the Stereo Output .....	88
Coaxial Digital Out & the Stereo Output .....	88
Option I/O & the Stereo Output .....	88
Omni Outs & the Stereo Output .....	88
Solo & the Stereo Output .....	88
Monitoring the Stereo Output .....	88

---

Metering the Stereo Output .....	89
Routing Signals to the Stereo Output .....	89
Viewing Stereo Output Settings .....	89
Setting the Stereo Output Level .....	90
Muting the Stereo Output .....	90
Balancing the Stereo Output .....	90
Applying EQ to the Stereo Output .....	90
Stereo Output Dynamics Processors .....	90
Stereo Output Delay .....	91
Stereo Output Block Diagram .....	92
<b>9 Aux Sends .....</b>	<b>93</b>
About the Aux Sends .....	94
Option I/O & the Aux Sends .....	94
Omni Outs & the Aux Sends .....	94
Monitoring Aux Sends .....	94
Metering Aux Sends .....	94
Sending Channel Signals to Aux Sends .....	95
Pre-fader/Post-fader Aux Sends .....	97
Viewing Aux Send Settings .....	98
Setting Aux Send Master Levels .....	99
Muting Aux Sends .....	100
Applying EQ to Aux Sends .....	100
Aux Send Dynamics Processors .....	100
Pairing Aux Sends .....	101
Aux Send Block Diagram .....	104
Stereo Pair Aux Send Block Diagram .....	105
<b>10 Bus Outs .....</b>	<b>107</b>
About the Bus Outs .....	108
Option I/O & the Bus Outs .....	108
Omni Outs & the Bus Outs .....	108
Monitoring Bus Outs .....	108
Metering Bus Outs .....	108
Routing Signals to the Bus Outs .....	108
Setting Bus Out Master Levels .....	109
Muting Bus Outs .....	109
Routing Bus Signals to the Stereo Bus .....	110
Pairing Bus Outs .....	111
Bus Out Block Diagram .....	112
Stereo Pair Bus Out Block Diagram .....	113
<b>11 Omni Outs .....</b>	<b>115</b>
About the Omni Outs .....	116
Omni Outs .....	116
Assigning Omni Outs .....	116
Omni Out Delay .....	117
Omni Out Block Diagram .....	118

---

---

<b>12 Effects</b> . . . . .	<b>119</b>
About the Onboard Effects . . . . .	120
Preset Effects Programs . . . . .	121
Using the Effects . . . . .	123
Pre-fader/Post-fader Effects Sends . . . . .	125
Viewing Effects Send Settings . . . . .	127
Metering Effects Sends . . . . .	127
Setting Effects Send Master Levels . . . . .	128
Muting Effects Sends . . . . .	129
Viewing Effects Returns Settings . . . . .	130
Metering Effects Returns . . . . .	130
Applying EQ to Effects Returns . . . . .	130
Muting Effects Returns . . . . .	130
Setting Effects Returns Levels . . . . .	131
Panning Effects Returns . . . . .	131
Routing Effects Returns . . . . .	131
Monitoring Effects Returns . . . . .	131
Effects Returns & Aux Sends . . . . .	131
Effects Library . . . . .	132
Storing Effects Programs . . . . .	133
Recalling Effects Programs . . . . .	134
Editing Effects Program Titles . . . . .	135
Editing Effects . . . . .	136
Setting Delay, Freq, Note & Tempo Parameters . . . . .	137
Effects Parameters . . . . .	138
Effects Block Diagram . . . . .	159
<b>13 Dynamics Processors</b> . . . . .	<b>161</b>
About the Dynamics Processors . . . . .	162
Preset Dynamics Programs . . . . .	163
Using the Dynamics Processors . . . . .	164
Editing the Dynamics Processors . . . . .	166
Processor Types . . . . .	167
Dynamics Library . . . . .	173
Storing Dynamics Programs . . . . .	174
Recalling Dynamics Programs . . . . .	175
Editing Dynamics Program Titles . . . . .	176
Preset Dynamics Program Settings . . . . .	177
<b>14 Scene Memories</b> . . . . .	<b>183</b>
About Scene Memories . . . . .	184
What's Stored in Scene Memories? . . . . .	184
About the Edit Buffer & Indicator . . . . .	185
Scene Memory 00 . . . . .	185
Scene Memory Display Area . . . . .	185
Storing Mix Scenes . . . . .	186
Recalling Mix Scenes . . . . .	187
Recalling Mix Scenes Using MIDI Program Change Messages . . . . .	188
Undoing Mix Scene Recalls . . . . .	189
Protecting Scene Memories . . . . .	189

---



---

Editing Scene Memory Titles .....	190
Renumbering Scene Memories .....	190
Setting a Fade Time .....	191
Recalling Scene Data Safely .....	192
<b>15 Other Functions .....</b>	<b>193</b>
Assigning Faders & On Buttons .....	194
Using the Oscillator .....	202
Setting 01V Preferences .....	203
Initializing the 01V .....	204
Calibrating the Faders .....	204
<b>16 Using the Digital Inputs &amp; Outputs .....</b>	<b>205</b>
About Wordclocks .....	206
Setting the Wordclock .....	209
Digital Stereo Out .....	211
Output Dither .....	212
Digital Stereo In .....	213
Cascading 01Vs .....	214
About Option I/O Cards .....	216
Installing Option I/O Cards .....	218
Assigning Option I/O Digital Outputs .....	219
Option I/O Block Diagram .....	220
<b>17 MIDI .....</b>	<b>221</b>
MIDI & the 01V .....	222
MIDI Ports .....	222
MIDI Receive Indicators .....	224
MIDI Setup .....	224
Program Change Scene Recall .....	227
Control Change Parameter Control .....	229
System Exclusive Parameter Control .....	231
Bulk Dump .....	232
Local Control .....	234
MIDI Machine Control .....	236
User Defined MIDI Controllers .....	238
Linking 01Vs .....	239
<b>18 System Examples .....</b>	<b>241</b>
01V & ADAT-Interface Recorder .....	242
Two 01Vs & two ADAT-Interface Recorders .....	244
01V & Tascam-Interface Recorder .....	246
Two 01Vs & two Tascam-Interface Recorders .....	248
01V & Pro Tools (AES/EBU) .....	250
<b>Troubleshooting .....</b>	<b>253</b>
<b>Appendix A: General .....</b>	<b>257</b>
01V Level Diagram .....	257
Display Messages .....	258

---

Security Cover .....	259
Rack-mounting Kit .....	259
<b>Appendix B: Specifications .....</b>	<b>261</b>
General .....	261
Input Channels 1–16 .....	263
Option I/O Inputs 17–24 (need optional card) .....	264
Digital Stereo In .....	264
Return 1, 2 (Internal Effect 1, 2) .....	264
Bus 1–4 .....	265
Aux 1–4 .....	265
Stereo Out .....	265
Omni Out 1–4 .....	265
Monitor Out (Solo) .....	266
Digital Stereo Out .....	266
Option I/O Output (need optional card) .....	266
Memories & Libraries .....	266
EQ .....	267
Analog Inputs .....	268
Analog Outputs .....	268
Digital Audio Inputs .....	269
Digital Audio Outputs .....	269
Option I/O Cards .....	269
Control I/O .....	270
01V Dimensions .....	271
<b>Appendix C: MIDI .....</b>	<b>273</b>
Scene Memory to Program Change Table .....	273
01V Parameter to Control Change Table .....	274
03D & Programmable Mixer 01 Parameter to Control Change Table .....	277
MIDI Data Format .....	280
<b>Appendix D: Resources .....</b>	<b>291</b>
Books .....	291
Yamaha Web Site .....	291
<b>Glossary .....</b>	<b>293</b>
<b>Index .....</b>	<b>297</b>

# Welcome to the 01V

---

# 1

## In this chapter...

Welcome to the 01V .....	2
About this Owner's Manual .....	2
01V Installation .....	2
01V Features .....	3
Key Feature Discussion .....	4

## Welcome to the 01V

Thank you for choosing the Yamaha 01V Digital Mixing Console. Based on the highly successful Yamaha digital mixer series, the Yamaha 01V has been designed with MIDI musicians and small sound reinforcement applications in mind, although its versatility, compactness, and ease-of-use will appeal to both professional and semiprofessional users.

## About this Owner's Manual

This Owner's Manual contains all the information you'll need in order to operate your 01V Digital Mixing Console. Use the table of contents to find general information and familiarize yourself with the organization of this manual, and use the index to locate specific items. A glossary of 01V-related jargon is provided on page 293.

Each chapter covers a specific section of the 01V. The Input Channels Chapter, for example, explains all about input channels, while the Scene Memories Chapter deals with scene memories. The content of each chapter should be fairly obvious from its title. Items such as EQ and dynamics, which are available on input channels, aux sends, and the stereo output, are explained in their own chapters.

Where possible, the individual sections of a chapter are organized in order of signal flow. The Input Channel Chapter, for example, starts with the input connectors and works through each input channel function, finishing up at the buses.

## 01V Installation

Site the 01V on a stable surface, somewhere that complies with the important information at the front of this manual. The 01V can be rack-mounted using an optional rack-mount kit.

---

## 01V Features

### 01V Sonic Specs

- Linear 20-bit 128-times oversampling A/D converters
- Linear 20-bit 8-times oversampling D/A converters (STEREO OUT)
- 105 dB typical dynamic range (CH INPUT to STEREO OUT)
- 20 Hz–20 kHz (+1, –3 dB) frequency response
- 32-bit internal digital audio processing
- 44-bit digital EQ processing

### 01V Features

- 24 inputs (including 8 digital inputs)
- 14 outputs (STEREO OUT, OMNI OUTs, 8 assignable digital outputs)
- Continuously variable gain controls
- Balanced XLRs with +48 V phantom powering (input channels 1 through 12)
- 26 dB pad (input channels 1 through 12)
- Balanced phone jack inputs (input channels 1 through 16)
- Four configurable analog Omni outs (AUX, BUS, CH DIRECT, STEREO)
- Option I/O slot for digital interface with 8-track digital multitrack recorders
- 8 assignable digital outputs from an Option I/O card (Tascam, ADAT, AES/EBU)
- Coaxial-type digital input and output
- Versatile solo modes for comprehensive monitoring
- 3 fader groups for multiple fader control
- 3 mute groups for multiple mute control
- 250 ms input delay (1–16) and 300 ms output delay (STEREO OUT, OMNI OUTs)
- Channel Copy function
- Stereo-pair operation for input channels, aux sends, and bus outs
- 100 scene memories for storing mix snapshots
- Four-band parametric EQ (2-band on Option I/O input channels)
- Powerful EQ library with 40 preset programs and 40 user programs
- Dedicated controls for EQ and pan
- Two stereo multi-effects processors onboard
- Powerful effects library with 42 preset programs and 57 user programs
- The equivalent of 22 dynamics processors onboard (compressor, gate, ducking, expander, compander)
- Powerful dynamics library with 40 preset programs and 40 user programs
- 320 x 80 dot LCD display
- Comprehensive MIDI implementation (remote control, MMC, Bulk)
- Built-in MIDI interface and TO HOST port for quick and simple connection to a personal computer
- 15 motorized 60 mm faders

## Key Feature Discussion

### Configuration

The 01V provides a total of 24 inputs: 12 mono input channels (1 through 12), 2 stereo input channels (13/14 and 15/16), and 8 digital inputs (17 through 24) by means of an Option I/O card. The stereo output signal is available from the analog STEREO OUT, coaxial DIGITAL STEREO OUT, and can be assigned to the analog OMNI OUTs and Option I/O digital outputs. The four bus outputs and four aux sends can be assigned to the analog OMNI OUTs and Option I/O digital outputs. The Effect 1 and Effect 2 buses feed the onboard stereo multi-effects processors, whose signals are returned via effects returns 1 and 2, which feature four-band parametric EQ. Input channels 1 through 12 feature balanced XLR and phone jack connections, with switchable phantom powering. Input channels 13 through 16 feature phone jack connections. Input channels 17 through 24 are accessed via an Option I/O card.

Full-feature input channels 1 through 16 feature an attenuator, four-band parametric EQ, dynamics processor, delay, and can be assigned to aux sends 1 through 4 and effects sends 1 and 2. Simplified input channels 17 through 24 feature an attenuator, two-band parametric EQ, and can be assigned to aux sends 1 and 2 and effects sends 1 and 2. Input channels 1 through 8 and 17 through 24 can be swapped, so that Option I/O digital input signals appear on full-feature channels 1 through 8. Input delays can be used for microphone-placement compensation, while output delays can be used for delay-compensation in multi-speaker systems. The number of input channels can be increased by digitally cascading two 01Vs together. Option I/O digital outputs can be configured as bus outs, aux sends, input channel direct outs, or stereo outs. So although the 01V is a four-bus mixer, assigning the four buses and four aux sends, or the channel direct outs to the Option I/O eight outputs allows eight-track simultaneous recording.

### Benefits of a Digital Mixer

You're probably already familiar with the many benefits offered by digital audio, but what exactly are the benefits for digital audio mixing? Well, an audio mixer has the job of combining audio signals from various sources, at differing levels and impedances, usually into a stereo mix. And it must do this without introducing any new distortions and noise. Analog mixers do a pretty good job, but even with the best designs, non-linear effects caused by circuit components are unavoidable.

In the digital realm, audio mixing consists of adding and multiplying binary numbers that represent audio signals. The DSP (Digital Signal Processor) chips used for these calculations never get their sums wrong, so once past the initial A/D conversion, audio signals are immune from signal degradation. With the 01V, noise, distortion, and crosstalk are virtually eliminated, and you'll hear a new clarity in your mixes.

Once in the digital domain, it makes sense to keep audio data digital, as multiple AD/DA conversions can degrade signal quality. With an Option I/O interface card, the 01V can be connected directly to a modular digital multitrack recorder, thereby keeping audio data in the digital domain for both recording and mixing. The final stereo mix can be transferred to a two-track digital recorder using the 01V's Coaxial STEREO OUT.

Onboard stereo multi-effects processors and dynamics processors mean that signals remain in the digital domain, eliminating unnecessary AD/DA conversions. Digital signal processing is performed using third-generation Yamaha DSPs, as used in the Yamaha ProR3 Digital Reverberator.

---

## 01V Sonic Performance

The 01V's linear 20-bit 128-times oversampling A/D converters provide a typical dynamic range of 105 dB. The STEREO OUT features 20-bit 8-times oversampling D/A converters, while the MONITOR OUT and OMNI OUTs feature 18-bit 8-times oversampling D/A converters. Oversampling techniques effectively increase the internal sampling rate, so side effects caused by steep low-pass filters, used to filter out sampling frequency components during D/A conversion, are virtually eliminated. Consequently, audio signal integrity is maintained from input through to output.

The 01V can generate the industry standard sampling rate of 44.1 kHz, or synchronize to an external wordclock source from 44.1 kHz  $-10\%$  to 48 kHz  $+6\%$ .

## Four-band Parametric EQ & Library

Input channels 1 through 16, the stereo output, aux sends, and effects returns all feature four-band fully parametric EQ, with variable gain, frequency, Q, and bypass. Input channels 17 through 24 feature a simplified two-band parametric EQ. High and low EQ bands can be used as shelving, peaking, or HPF and LPF, respectively. See “EQ” on page 61 for more information.

EQ settings can be stored in the EQ library as programs, or with all mix settings in mix scenes. The EQ library consists of 40 preset programs and 40 user programs. User programs allow you to store frequently used EQ settings, which can be titled for easy identification. The unique collection of preset EQ programs are designed for specific applications and instruments, and provide a good reference and starting point when making EQ adjustments. See “EQ Library” on page 67 for more information.

## Motorized Faders

The 01V features 15 motorized 60 mm faders that move automatically when a mix scene is recalled, providing a clear and visual indication of fader levels. A fade time of up to 25 seconds can be set for each mix scene individually. Faders can be grouped together in one of three fader groups for multiple fader control. See “Grouping Faders” on page 55 for more information. Faders on paired channels move simultaneously. See “Pairing Input Channels” on page 52 for more information.

01V Faders are multifunction controls, and their exact operation depends on the selected Fader mode. Input channel faders may be used as channel faders or aux or effects send controls. The STEREO fader may be used as the stereo output fader or aux or effects send master level faders. See “Fader Modes” on page 32 for more information.

Faders 1 through 16 and master can be assigned to various internal parameters on REMOTE page 1, or used as MIDI controllers on REMOTE page 3. See “Assigning Faders & On Buttons” on page 194 and “User Defined MIDI Controllers” on page 238 for more information.

## Onboard Effects Processors

The 01V has two stereo multi-effects processors onboard: Effect 1 and Effect 2. These processors provide a wide range of quality effects, including reverb, delay, chorus, flange, amp simulator, and more. There are 34 different effects types available. The effects processors are fed by the Effect 1 and Effect 2 buses, and the processed signals are returned through the effects return channels. Effects can be applied to input channels 1 through 24. Effects return 1 can be fed to Effect 2, and Effects return 2 can be fed to Effect 1.

Effects settings can be stored in the effects library as programs, or with all mix settings in mix scenes. The effect library consists of 42 preset programs and 57 user programs. User programs allow you to store your own effects programs, which can be titled for easy identification. See “Effects Library” on page 132 for more information.

External effects processors can be patched into the 01V using the aux sends.

## Onboard Dynamics Processors

Dynamics processors, providing compressor, gate, ducking, expander, and compander, are available on input channels 1 through 16, the stereo output, and the aux sends. That’s equivalent to 22 dynamics processors! Dynamics processors can be self triggering (i.e., the signal being processed is used as the trigger signal), or triggered by a signal from another channel.

Dynamics settings can be stored in the dynamics library as programs, or with all mix settings in mix scenes. The dynamics library consists of 40 preset programs and 40 user programs. User programs allow you to store your own dynamics programs, which can be titled for easy identification. See “Dynamics Library” on page 173 for more information.

## Option I/O & Digital I/O

The 01V features a single slot for an optional Option I/O card, providing eight digital inputs (input channels 17 through 24) and eight assignable digital outputs. Option I/O provides a direct digital connection to modular digital multitrack recorders, with cards for the following formats: ADAT, Tascam, and AES/EBU. An Option I/O card offering four analog outputs is also available. See “About Option I/O Cards” on page 216 for more information. 01V Option I/O cards are not interchangeable with the YGDAI cards used by the Yamaha 02R and 03D Digital Recording Consoles, such as the CD8-AT.

The Coaxial DIGITAL STEREO IN and OUT allow direct connection to stereo digital recorders and other digital equipment. Digital stereo signals can be routed to the Stereo bus for cascade operation, or to input channels 13/14 for mixing and processing. See “Digital Stereo In” on page 213 for more information.

## Easy-to-Learn GUI Interface

01V operation is both logical and intuitive. The 320 x 80 dot LCD display uses graphical icons to represent rotary controls, switches, and faders, and provides a clear indication of the current mix settings and EQ curves. Dedicated controls allow for quick EQ and pan adjustments. Mixing functions and configuration settings are organized into display pages. Parameter selection and editing is performed using the [CURSOR], [ENTER], [–1/DEC] and [+1/INC] buttons, and PARAMETER wheel.



## Scene Memories

On many mixers, the only way to store mix settings is with marker pen and masking tape. With the 01V, however, virtually every mix setting can be stored in a mix scene using the 01V's 99 scene memories. Mix scenes can be recalled instantly with just one button press, or remotely using MIDI Program Change commands. If you work on several projects at a time, you can store the current mix scene so when you return to that project, you can start again right where you left off. Scene memories also make light work of night-after-night sound checks. Simply press recall to return to the previous night's mix settings. For theater work, scene memories allow accurate and repeatable sound changes between scenes.

## MIDI

In addition to regular MIDI ports, the 01V features a TO HOST port that allows the 01V to be connected directly to a personal computer without a MIDI interface.

MIDI Program Change messages can be used to recall mix scenes, and mix parameters can be assigned to MIDI Control Change messages for real-time remote control. Mix parameters that can be stored in mix scenes can be controlled remotely using MIDI System Exclusive messages. Scene memory, library, and setup data can be transferred to a MIDI data file, computer, or another 01V for backup and archive using MIDI Bulk Dump. See "MIDI" on page 221 for more information.

When REMOTE page 2 is displayed, the 01V's [SEL] and [ON] buttons can be used to control recorders that support MMC (MIDI Machine Control) commands (stop, play, rewind, forward, and record). When REMOTE page 3 is displayed, faders, [SOLO] & [ON] buttons function as assignable MIDI Controllers.

---

# Getting Started

---

A large, bold, gray number '2' is positioned on the right side of the page, partially overlapping a black rectangular shape that extends from the right edge.

## In this chapter...

01V System Example .....	10
Important Wordclock Information .....	11
Connecting the Power Cord .....	11
Turning On the 01V .....	11
Turning Off the 01V .....	11

# 01V System Example

This example shows the kind of system possible with the 01V.

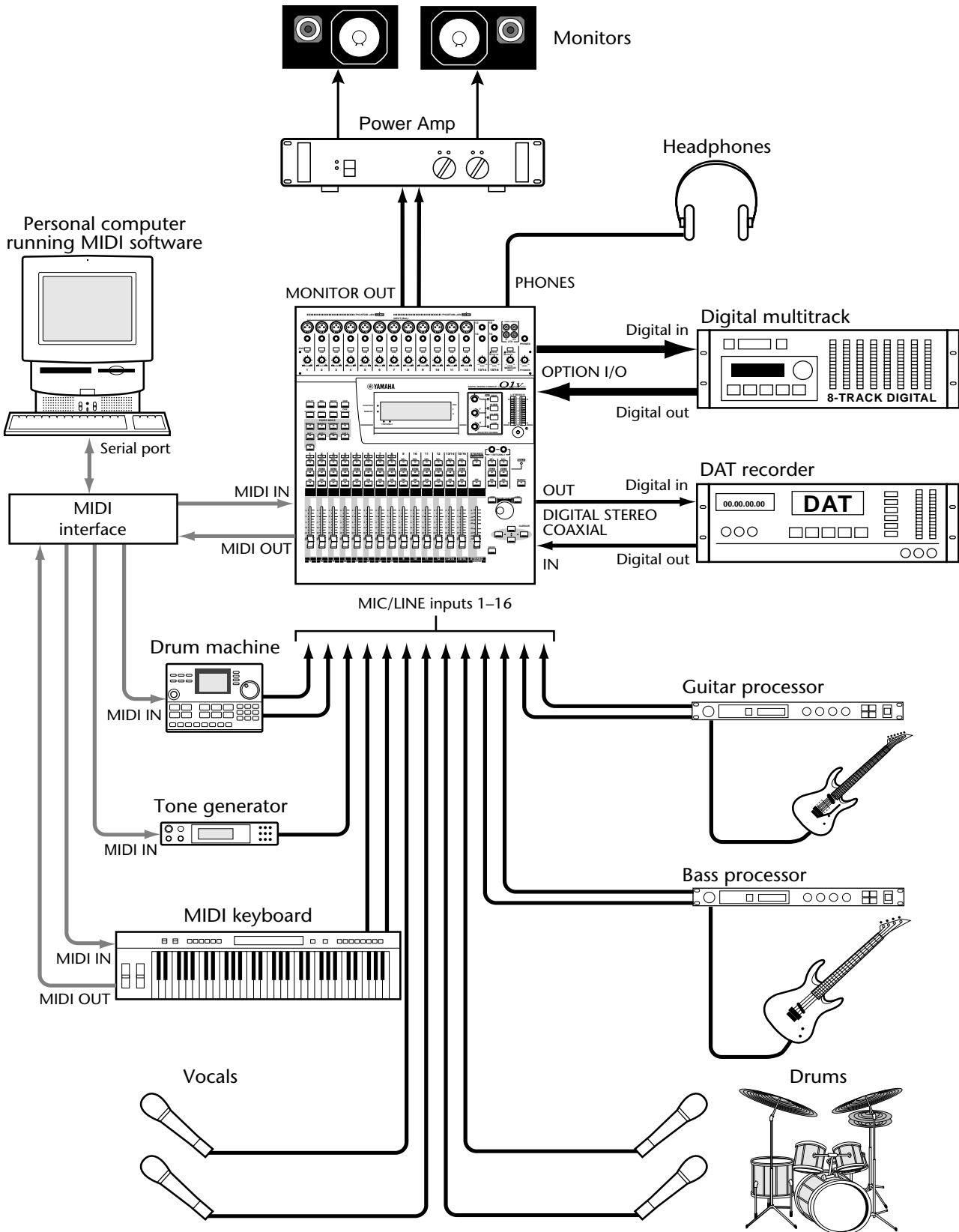

## Important Wordclock Information

Unlike analog audio equipment, digital audio equipment must be *wordclock* synchronized when digital audio is transferred from one device to another. See “About Wordclocks” on page 206 for more information.

If the 01V is the only digital audio device in your system, no special wordclock settings are required, and the 01V synchronizes to its own internal wordclock. Add a DAT recorder or digital multitrack recorder, however, and the system must be configured so that digital audio equipment synchronizes to a common wordclock source. The “System Examples” on page 241 show how to configure wordclock settings with a variety of digital audio equipment.

## Connecting the Power Cord

**Warning:** Turn off all equipment before making any connections.

Connect the 01V power cord to a suitable AC wall outlet, one that conforms to the power supply requirements stated on the rear panel of the 01V.

## Turning On the 01V

Always turn on your audio equipment in the following order:

1. **Sound sources**
2. **01V**
3. **Monitor amplifier**

To turn on the 01V, press the 01V POWER switch located on the rear panel.

When turned on, the 01V startup screen appears for a few seconds, and then the display page selected when the 01V was last turned off appears.

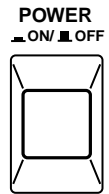

## Turning Off the 01V

Always turn off your audio equipment in the following order:

1. **Monitor amplifier**
2. **01V**
3. **Sound sources**

To turn off the 01V, press the 01V POWER switch located on the rear panel.

All parameter settings, scene memories, and library programs are stored when the 01V is turned off.

# Touring the 01V

---

# 3



## In this chapter...

Top Panel Controls .....	14
Inputs & Outputs .....	20
Block Diagram .....	24

# Top Panel Controls

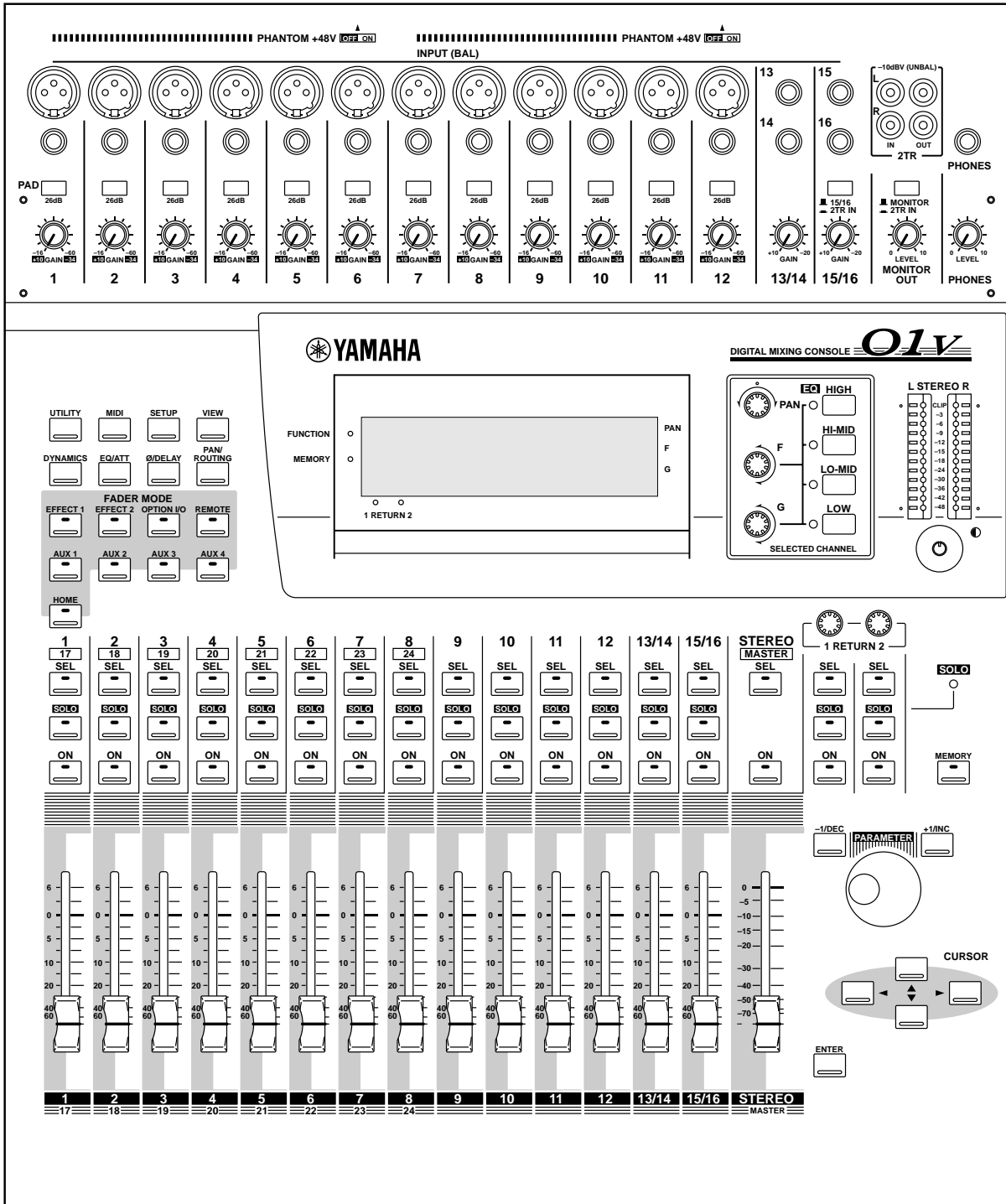

The individual sections of the 01V are explained on the following pages.

## Analog Control Section

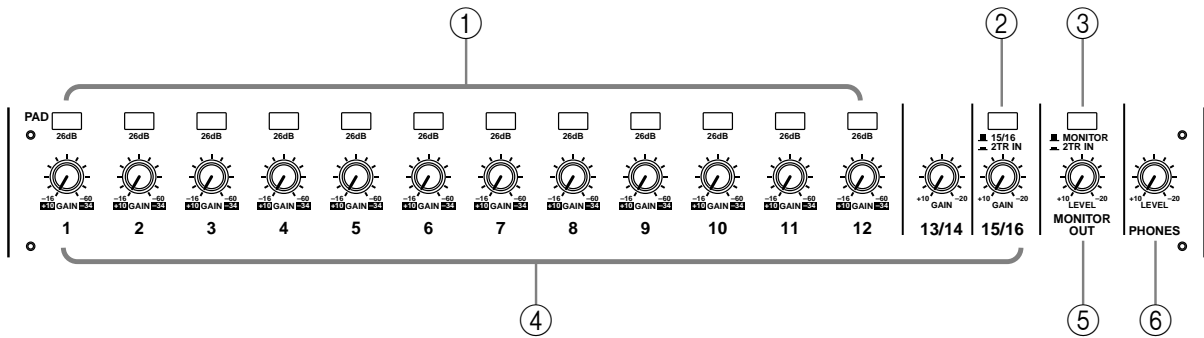

① **PAD switches**

These switches are used to turn on and off the 26 dB input pads. See “Pad Switches” on page 41 for more information.

② **15/16–2TR IN Switch**

This switch is used to select the signal source for input channels 15 and 16: phone jacks 15 and 16 (15/16) or the 2TR IN phono jacks (2TR IN).

③ **MONITOR–2TR IN Switch**

This switch is used to select the signal source for the monitor out and phones: Monitor bus (MONITOR) or 2TR IN phono jacks (2TR IN).

④ **GAIN controls**

These controls are used to adjust the gain of the input preamps. See “Setting Input Channel Gain” on page 41 for more information.

⑤ **MONITOR OUT LEVEL control**

This control is used to adjust the monitor out level.

⑥ **PHONES LEVEL control**

This control is used to adjust the phones level.

## Display, Selected Channel Controls & Meters

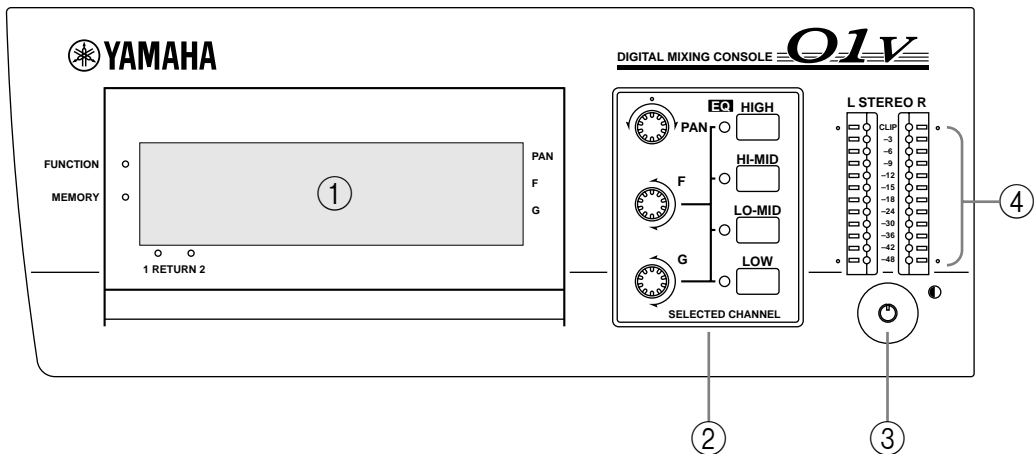

① **Display**

This 320 x 80 dot LCD display provides clear indication of mix settings and operating status. As well as showing parameter values numerically, faders and rotary controls are represented graphically, so you can actually see pan and fader positions. The display also shows EQ curves and signal level meters. See “Display” on page 28 for more information.

② **SELECTED CHANNEL Controls**

These controls are used to adjust the pan and EQ of the selected channel. Dedicated rotary controls for PAN, EQ frequency (F) and EQ gain (G), and EQ [HIGH], [HI-MID], [LO-MID], and [LOW] buttons make for quick operation. When the EQ AUTO SCREEN option is turned on, and an EQ control is adjusted, the EQ page appears automatically. Likewise, for the PANPOT AUTO SCREEN option and PAN control. See “Setting 01V Preferences” on page 203 for more information.

③ **Contrast**

This control is used to adjust the display contrast. Adjust it so that the display is clear and easy-to-read from your viewing position. You may need to readjust it when viewing the display from a different height or angle.

④ **Stereo Output Meters**

These 12-segment LED bar-type meters display the stereo output signal levels.

## Parameter Wheel, Cursors & Enter

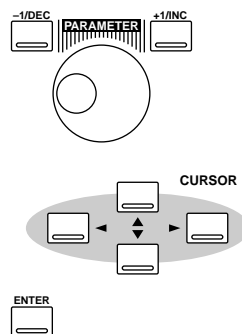

These controls are used to navigate around the display pages and edit parameters. See “Getting Around the User Interface” on page 27 for more information.



## Function Buttons

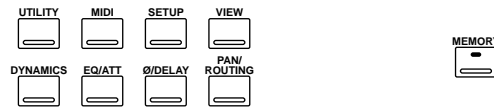

Function buttons are used to access the following function pages. Related pages are grouped together and can be selected by repeatedly pressing a button. The name of the selected function and its page number appear in the top-left corner of the display.

Button	Pages
<b>UTILITY</b>	Oscillator, Preferences-1, Preferences-2
<b>MIDI</b>	MIDI Setup, Program Change, Control Change, Bulk, Local Control
<b>SETUP</b>	Word Clock Select, Monitor/Solo Setup, Group, Pair, Dither
<b>VIEW</b>	Channel View, Fader View, CH Copy
<b>DYNAMICS</b>	Dynamics Edit, Dynamics Library
<b>EQ/ATT</b>	EQ Edit, EQ Library
<b>Ø/DELAY</b>	Phase, Input Delay 1–8, Input Delay 9–16, Output Delay
<b>PAN/ROUTING</b>	Panpot, Routing, Bus Master, Omni Out Select
<b>MEMORY</b>	Memory, Fade Time, Memory Sort, Recall Safe

## Fader Mode Buttons

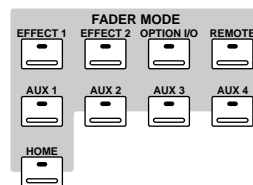

Fader mode buttons are used to select the following fader modes and display pages. Pressing buttons repeatedly selects the various pages that are available for a mode. The name of the selected function and its page number appear in the top-left corner of the display.

Button	Pages
<b>EFFECT 1</b>	Effect1 Edit, Effect1 Library, Effect1 Pre/Post
<b>EFFECT 2</b>	Effect2 Edit, Effect2 Library, Effect2 Pre/Post
<b>OPTION I/O</b>	Option In Meter, Channel Control, Option Out Meter, Option Out Select, Input Swap
<b>REMOTE</b>	Internal Parameter, MMC Control, User Define
<b>AUX 1</b>	Pre/Post, Aux 1-2 Pan
<b>AUX 2</b>	Pre/Post, Aux 1-2 Pan
<b>AUX 3</b>	Pre/Post, Aux 3-4 Pan
<b>AUX 4</b>	Pre/Post, Aux 3-4 Pan
<b>HOME</b>	Input Meter, Rtn/Output Meter, Omni Out Meter, St Out Meter, Metering Point

## SEL, SOLO, ON buttons & Faders

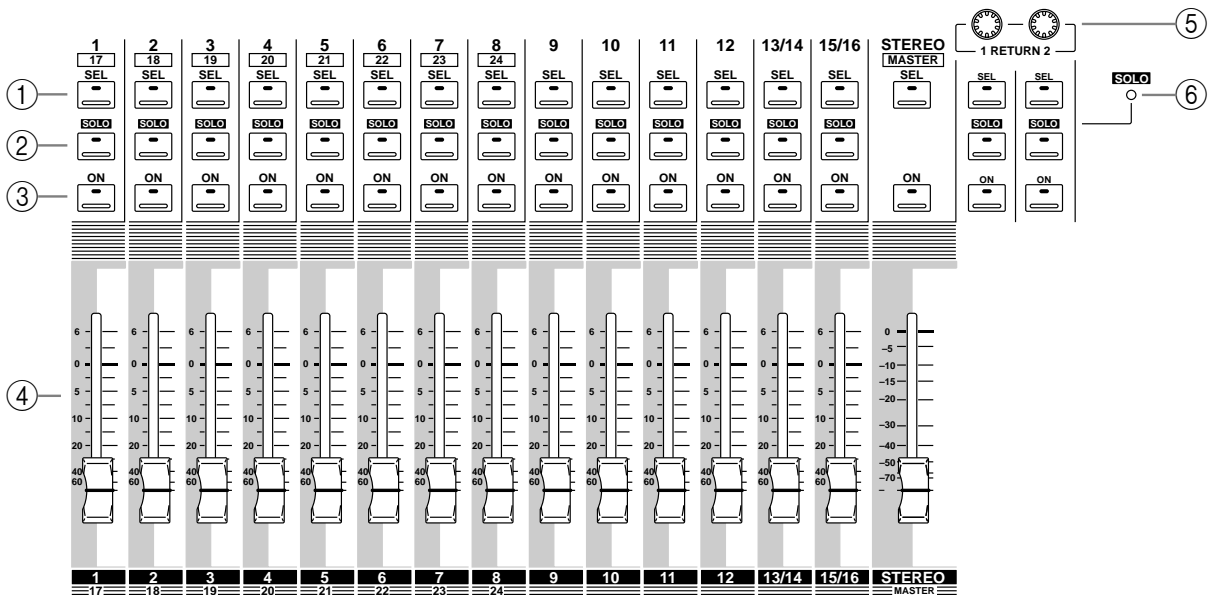

### ① SEL buttons

The [SEL] buttons are used to select channels for parameter editing: input channels 1 through 24, effects returns 1 and 2, aux sends 1 through 4, effects sends 1 and 2, and the stereo output. Press [SEL] button 13/14 or 15/16 repeatedly to select input channels 13 and 14 or 15 and 16, respectively. Since most functions on input channels 13 and 14 (likewise 15 and 16) are linked together, the only time you'll need to select either channel 13 or channel 14 (likewise 15 or 16) is to set the Phase or Pan for a channel individually. The number of the selected channel appears in the lower-right corner of the display. See “Display” on page 28 for more information.

Normally, [SEL] buttons 1 through 8 select channels 1 through 8. When the [OPTION I/O] button is pressed, however, they select input channels 17 through 24, which are only available when an Option I/O card is installed. See “SEL Buttons” on page 32 for more information. The [SEL] buttons 1 through 6 are also used to transmit MMC (MIDI Machine Control) Locate commands when REMOTE page 2 is displayed. Finally, [SEL] buttons are also used to make and break channel pairs (“Pairing Input Channels” on page 52) and fader and mute groups (“Grouping Faders” on page 55 and “Grouping Mutes” on page 56).

### ② SOLO buttons

The [SOLO] buttons are used to solo channels: input channels 1 through 16 and effects returns 1 and 2. Normally, [SOLO] buttons 1 through 8 select channels 1 through 8. When the [OPTION I/O] button is pressed, however, they select input channels 17 through 24, which are only available when an Option I/O card is installed. See “Solo Buttons” on page 33 for more information.

The [SOLO] buttons 1 through 16 can also be used as MIDI controllers on REMOTE page 3. See “User Defined MIDI Controllers” on page 238 for more information.

### ③ ON buttons

The [ON] buttons are used to turn channels on and off: input channels 1 through 24, effects returns 1 and 2, aux sends 1 through 4, effects sends 1 and 2, and the stereo out-

put. Normally, [ON] buttons 1 through 8 select channels 1 through 8. When the [OPTION I/O] button is pressed, however, they select input channels 17 through 24, which are only available when an Option I/O card is installed. See “ON Buttons” on page 34 for more information.

The [ON] buttons 1 through 16 and master can be assigned to various internal parameters on REMOTE page 1, or used as MIDI controllers on REMOTE page 3. See “Assigning Faders & On Buttons” on page 194 and “User Defined MIDI Controllers” on page 238 for more information.

④ **Faders**

Depending on the selected fader mode, the 01V’s 60 mm motorized faders are used to control channel levels, aux send levels, or effects sends levels. Normally, faders 1 through 8 control channels 1 through 8. When the [OPTION I/O] button is pressed, however, they control input channels 17 through 24, which are only available when an Option I/O card is installed. See “Faders (plus Return Rotary Controls)” on page 35 for more information.

Faders 1 through 16 and master can be assigned to various internal parameters on REMOTE page 1, or used as MIDI controllers on REMOTE page 3. See “Assigning Faders & On Buttons” on page 194 and “User Defined MIDI Controllers” on page 238 for more information.

⑤ **RETURN Controls**

The RETURN controls are used to adjust the effects return levels, and their positions are displayed in the lower-left corner of the display.

⑥ **SOLO Status Indicator**

The SOLO status indicator lights up when a channel is soloed.

## Inputs & Outputs

Input and output connectors are located on the top and rear panels.

### Top Panel

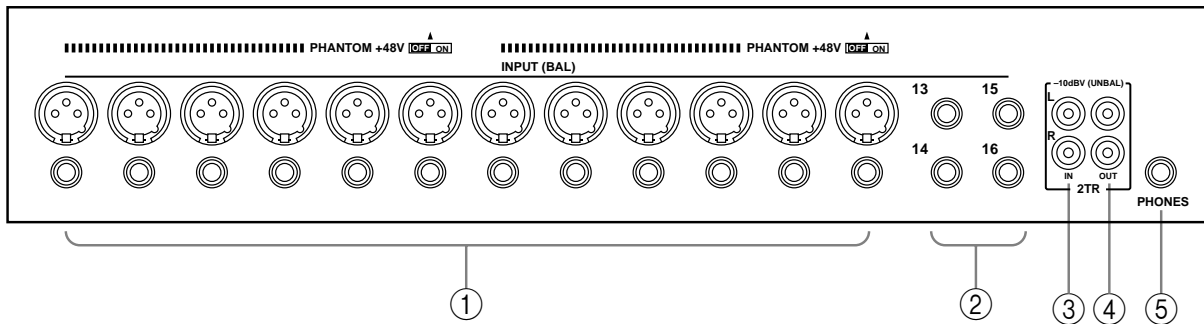

#### ① INPUT (BAL) 1–12

Input channels 1 through 12 feature balanced XLR-3-31-type and balanced phone jack connectors, both with a nominal input range of  $-60$  dB to  $+10$  dB. Phantom powering ( $+48$  V) is supplied to the XLR connectors, with master on/off switches for connectors 1 through 6 and 7 through 12. Phone jacks, which can also be used with unbalanced phone plugs, have priority over the XLR-type connectors, so when a phone plug is inserted, the XLR-type connector is disconnected. With their high sensitivity and 26 dB PAD switches, these inputs can handle a wide range of signals, from condenser microphones to “hot” line levels.

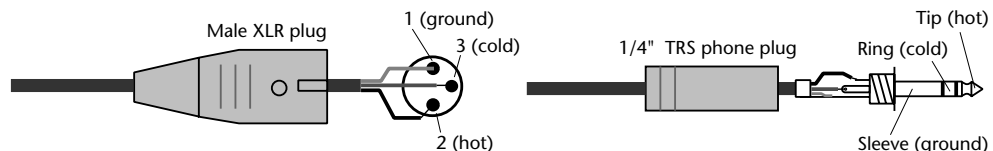

#### ② INPUT (BAL) 13–16

Input channels 13 through 16 feature balanced phone jack connectors, with a nominal input range of  $-20$  dB to  $+10$  dB. These inputs are designed for use with line-level sources, and can also be used with unbalanced phone plugs. The stereo outputs of an external effects processor or other stereo device can be connected here.

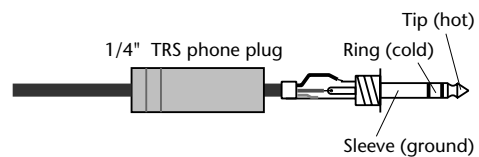

③ **2TR IN**

These are phono jacks with a  $-10$  dBV nominal input level. Signals input here can be monitored via the monitor out and phones when the MONITOR–2TR IN switch is set to 2TR IN. The stereo outputs of a master recorder can be connected here for confidence monitoring and master playback. By setting the 15/16–2TR IN switch to 2TR IN, 2TR IN signals can be fed to input channels 15 and 16 for mixing with other signals.

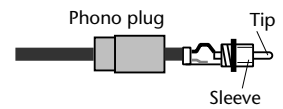
④ **2TR OUT**

These are phono jacks with a  $-10$  dBV nominal output level. The 2TR OUT signal is the same as the stereo out signal. A cassette deck, DAT, or MiniDisc deck connected here can be used to record the stereo mix.

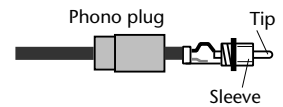
⑤ **PHONES**

This is a stereo (TRS) phone jack, to which a pair of stereo headphones can be connected for monitoring. The phones signal is the same as the monitor out signal, and the level is set using the phones level control.

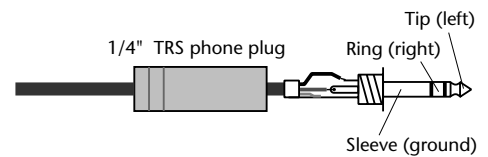

## Rear Panel

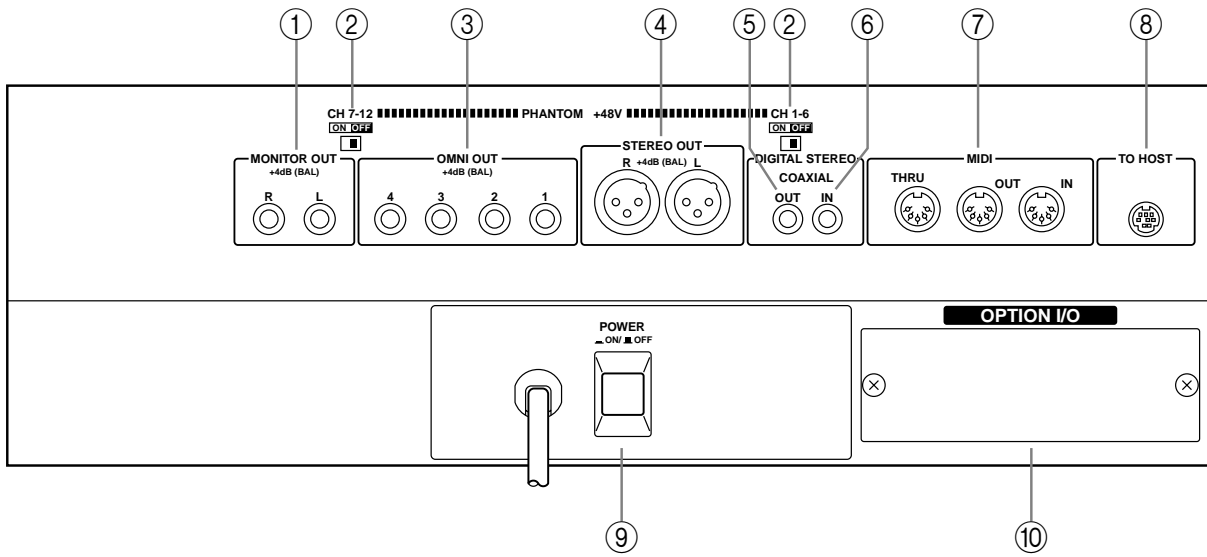

① **MONITOR OUT**

These are balanced 1/4-inch phone jacks with a +4 dB nominal output level. Balanced or unbalanced phone plugs can be connected. They output the monitor signals and should be connected to the inputs on a monitor amplifier. The monitor signal source is set using the MONITOR–2TR IN switch and SETUP page 2, and the output level is set using the MONITOR LEVEL control.

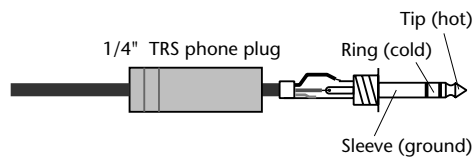

② **PHANTOM +48V ON–OFF Switches**

The CH 1–6 and CH 7–12 PHANTOM +48V ON–OFF switches are used to turn on and off the +48 V phantom power for XLR inputs 1 through 6 and 7 through 12, respectively.

③ **OMNI OUTs**

These are balanced 1/4-inch phone jacks with a +4 dB nominal output level. Balanced or unbalanced phone plugs can be connected. These outputs can be configured individually as analog bus outs, aux sends, stereo outs, or direct outs for input channels 1 through 16. Bus outputs are typically connected to multitrack recorders, while aux sends are typically used to feed external effects processors, foldback amplifiers, and so on.

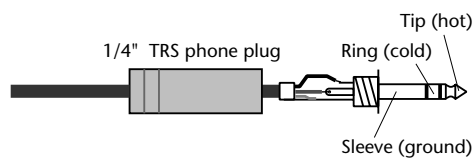

#### ④ STEREO OUT

These are balanced XLR-3-32-type connectors with a +4 dB nominal output level. They are wired pin 1–ground, pin 2–hot (+), and pin 3–cold (–). They output the main stereo mix.

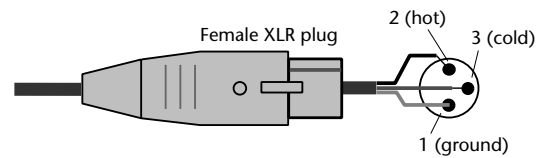

If you need to connect the balanced ST OUT to an unbalanced phone jack input, use a cable with the following wiring scheme (i.e., XLR pins 3 and 1 linked).

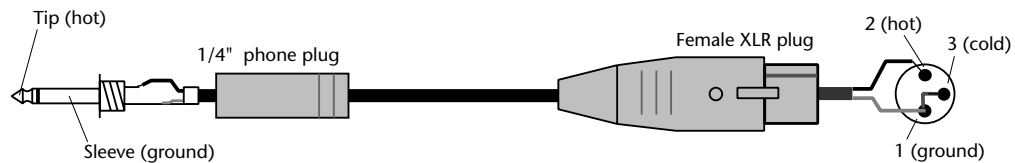

#### ⑤ DIGITAL STEREO OUT

This phono jack outputs the main stereo mix as Coaxial format 24-bit digital audio, allowing digital transfer to a DAT, MiniDisc deck, or other digital recorder.

#### ⑥ DIGITAL STEREO IN

This phono jack accepts 24-bit Coaxial format digital audio. Signals input here can be fed directly to the Stereo bus for stereo cascade operation (i.e., two mixers working together), or to input channels 13 and 14.

#### ⑦ MIDI IN, OUT, THRU

These are standard MIDI IN, OUT, and THRU ports and are used to connect the 01V to other MIDI equipment for remote control and data backup. The MIDI IN port receives MIDI messages, while the MIDI OUT port transmits them. The MIDI THRU port transmits all MIDI messages received at the MIDI IN port.

#### ⑧ TO HOST

This 8-pin mini DIN port is used to connect the 01V to a personal computer for use with MIDI software. It eliminates the need for a computer MIDI interface, and together with the MIDI ports allows the 01V to be used as a MIDI interface for other MIDI equipment.

#### ⑨ POWER switch

This switch is used to turn on and off the 01V. It's recessed to prevent accidental operation.

#### ⑩ OPTION I/O slot

An Option I/O card can be installed here, providing access to the 01V's eight digital inputs and outputs. See "About Option I/O Cards" on page 216.

# Block Diagram

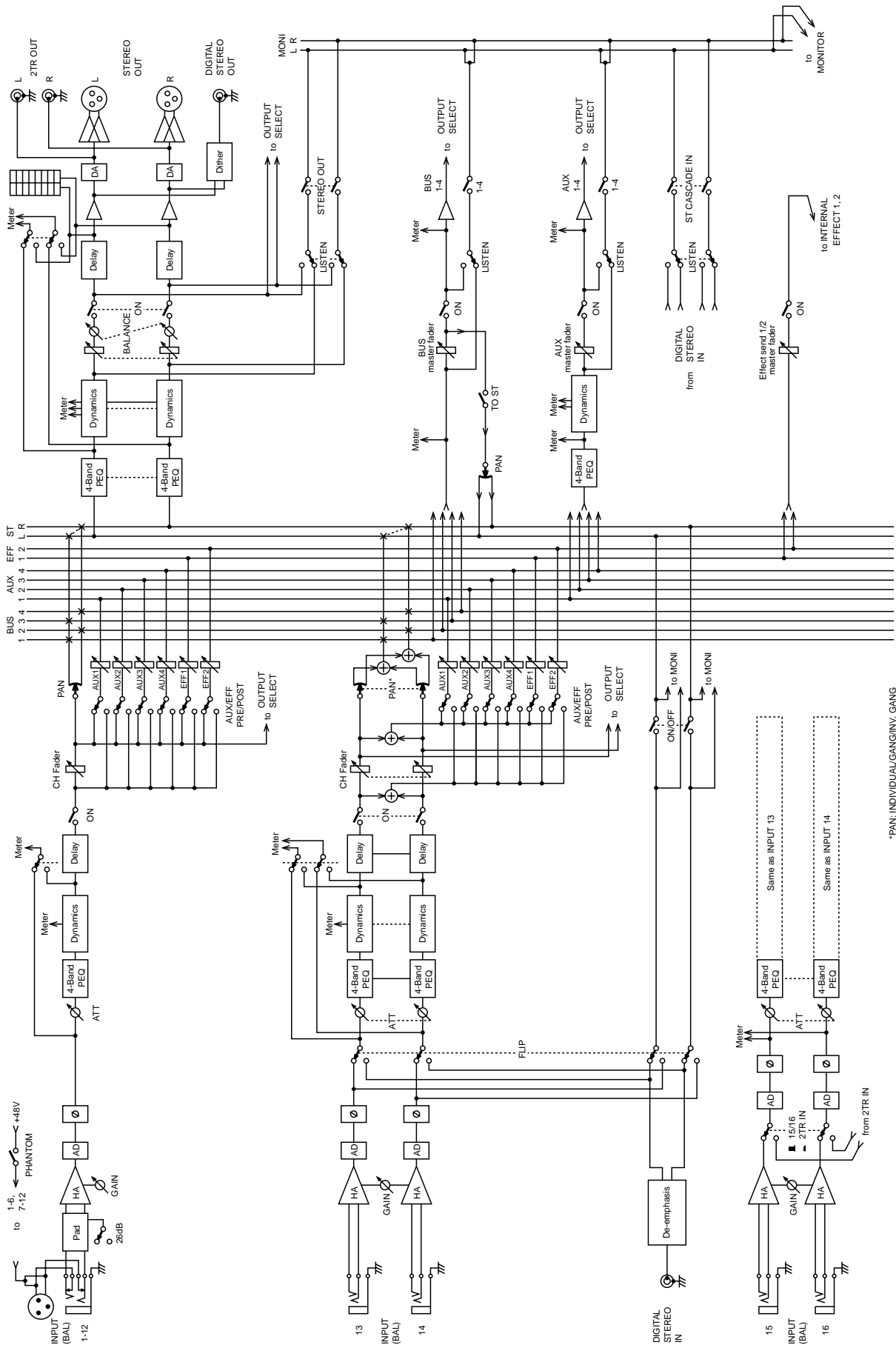

\*PAN: INDIVIDUAL/GANG/INV. GANG



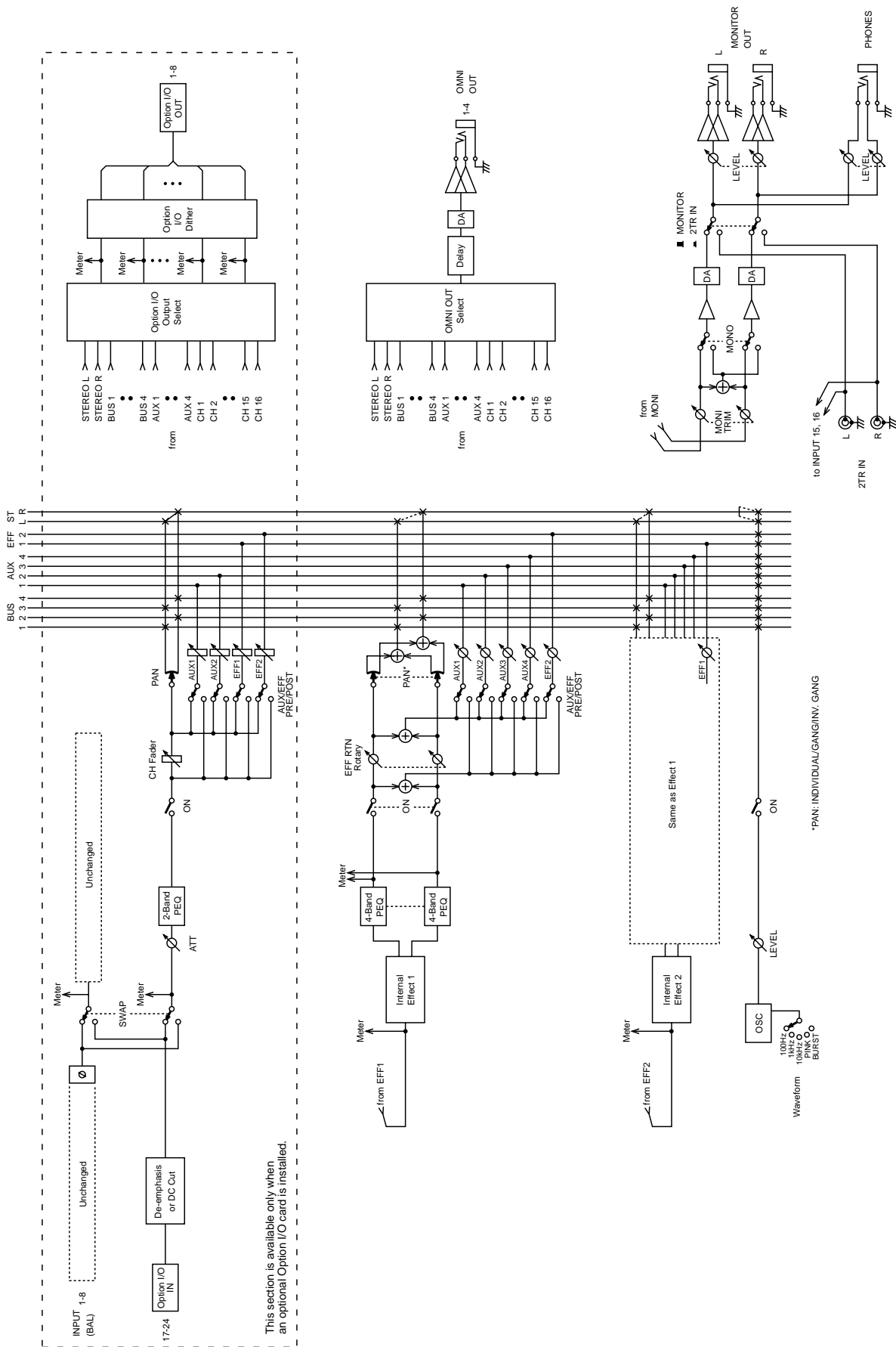

This section is available only when an optional Option I/O card is installed.

# Getting Around the User Interface

---

# 4



## In this chapter...

About the User Interface .....	28
Display .....	28
Display Elements .....	30
Cursor Buttons .....	31
PARAMETER Wheel .....	31
-1/DEC & +1/INC Buttons .....	31
ENTER Button .....	31
Fader Modes .....	32
Title Edit Dialog Box .....	37

## About the User Interface

Thanks to a user-friendly interface, 01V operation is both logical and intuitive. The 320 x 80 dot LCD display provides clear indication of mix settings and operating status, while dedicated SELECTED CHANNEL controls allow for quick EQ and pan adjustments. Operation of the multifunction faders depends on the selected Fader mode. Mixing functions and configuration settings are organized into display pages, with up to five related pages being grouped together. For example, the MIDI Setup and Program Change pages are grouped together under MIDI. Parameter selection and editing is carried out using the [CURSOR], [ENTER], [-1/DEC] and [+1/INC] buttons, and PARAMETER wheel, which is detented for precise and accurate editing.

## Display

The 320 x 80 dot LCD display provides clear indication of mix settings and operating status. As well as showing parameter values numerically, faders and rotary controls are represented graphically, so you can actually see pan and fader positions. The display also shows EQ curves and signal level meters. The various sections of the display are explained below.

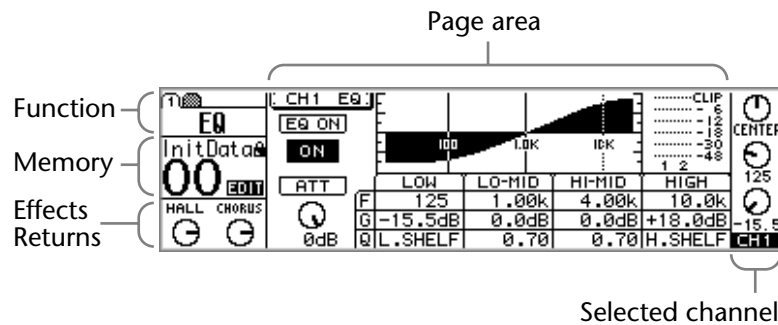

**Function**—This area of the display shows the name of the function selected using the Function and Fader mode buttons. Functions are divided into pages, which are identified by numbered tabs, as shown here. In this example, page 1 of the VIEW function is selected. The following functions can be selected.



Function Buttons	Fader Mode Buttons
UTILITY	EFFECT 1
MIDI	EFFECT 2
SETUP	OPTION I/O
VIEW	REMOTE
DYNAMICS	AUX 1
EQ/ATT	AUX 2
ø/DELAY	AUX 3
PAN/ROUTING	AUX 4
MEMORY	HOME

**Memory**—This area of the display shows the number and title of the selected scene memory, whether that scene memory is read only or write protected (indicated by the closed padlock icon), and whether or not the contents of the Edit Buffer have been edited. See “Scene Memory Display Area” on page 185 for more information. Also in the Memory area are the MIDI and HOST indicators, which appear when MIDI data is received at the MIDI IN or TO HOST port, respectively. See “MIDI Receive Indicators” on page 224 for more information.



**Effects Returns**—This area of the display shows two control icons, which indicate the positions of the RETURN level controls, and the type of effects selected for the two onboard effects processors: Effect 1 and Effect 2. When the EFFECT 1 or EFFECT 2 Fader mode is selected, the corresponding control icon is highlighted.

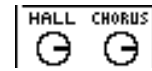

**Selected channel**—This area of the display shows three control icons: Pan, EQ frequency (F), and EQ gain (G), which indicate the pan, EQ frequency, and EQ gain of the selected channel. Below these is the selected channel indicator, showing which channel is currently selected. The following channels can be selected.

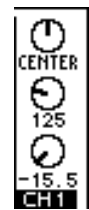

- **CH1 through CH24**—Input channels 1 through 24
- **ST**—Stereo output
- **RTN1, RTN2**—Effects returns 1 and 2
- **AUX1 through AUX4**—Aux sends 1 through 4
- **EFF1, EFF2**—Effects sends 1 and 2
- **1–16, MAS**—Remote function channels

When channels 13 through 16, the effects return channels, or paired input channels from 1 through 12 are selected, dotted lines appear to the right of these control icons when an odd or left channel is selected. Similarly, dotted lines appear to the left, as shown here, when an even or right channel is selected.

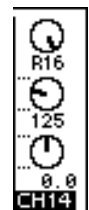

**Page area**—This area of the display is where the various setup, utility, and mixing function pages appear. As well as showing parameter values numerically, faders and rotary controls are represented graphically, so you can actually see pan and fader positions. See “Display Elements” on page 30 for more information. An example page is shown below.

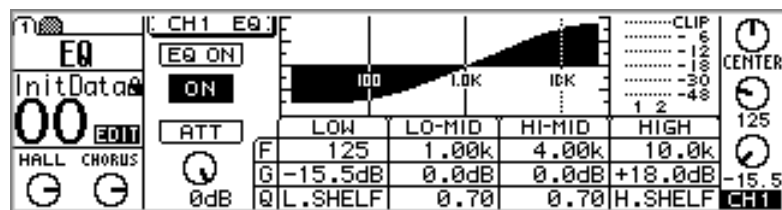

## Display Elements

This section explains the various control elements that appear on display pages.

### Switches

Switches appear as boxes with a shadowed outline (i.e., a thicker outline on the right side and bottom).



Simple on/off-type switches are highlighted when they are turned on. In this example, the [ST] switch is on.



The labels inside some switches change when they are turned on and off, as these phase switches show.



For option-type switches, only one switch can be on at a time. In this example, the monitor source can be set to either stereo out or ST CASCADE IN, but not both.



To operate a switch, use the cursor buttons to select it, and the [ENTER] button or [-1/DEC] and [+1/INC] buttons to turn it on or off.

### Rotary Controls

Some parameters appear as rotary controls, as this example from the PANPOT page shows. To adjust a rotary control, use the cursor buttons to select it and use the PARAMETER wheel or [-1/DEC] and [+1/INC] buttons to adjust it.



### Parameter Boxes

Some parameters appear in parameter boxes (i.e., dotted-line boxes), as this example from the EFFECT1 EDIT page shows. To adjust a parameter box parameter, use the cursor buttons to select it, and the PARAMETER wheel or [-1/DEC] and [+1/INC] buttons to set it. Parameter boxes that require you to confirm new settings flash until you press the [ENTER] button.

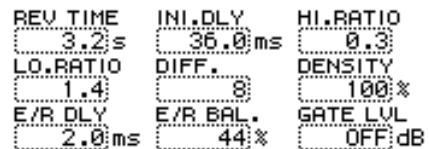

### Faders

Pages such as VIEW and BUS MASTER display faders graphically. To adjust a fader, use the cursor buttons to select it, and the PARAMETER wheel or [-1/DEC] and [+1/INC] buttons to set it. Fader knobs appear highlighted when set to the nominal position.

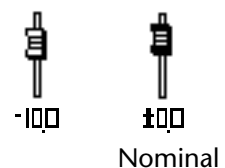

## Cursor Buttons

The cursor buttons are used to move the cursor around the display pages, selecting parameters and options. The cursor appears as a flashing box, making it easy to see which parameter or option is currently selected. Holding down a cursor button moves the cursor continuously in the respective direction.

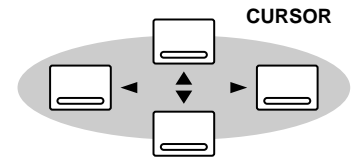

## PARAMETER Wheel

The PARAMETER wheel is used to adjust parameter values, scroll through scene memory and library programs, and position the cursor when titling scene memories, effects programs, and so on. Its detented action gives it a positive feel, allowing quick and accurate parameter editing. Turning it clockwise increases parameter values; turning it counterclockwise decreases them.

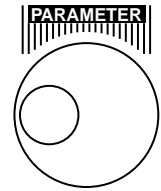

## -1/DEC & +1/INC Buttons

Like the PARAMETER wheel, the [-1/DEC] and [+1/INC] buttons are used to adjust parameter values, scroll through scene memory and library programs, and position the cursor when titling scene memories, effects programs, and so on. The [-1/DEC] button is used to decrement values, while the [+1/INC] button is used to increment them. Holding down the [-1/DEC] or [+1/INC] button sweeps through a parameter's adjustable range. When titling memories or programs, the [-1/DEC] button is used to toggle between uppercase, lowercase, and numerals, while the [+1/INC] button is used to insert spaces.



## ENTER Button

The [ENTER] button is used to activate parameter settings selected using the [CURSOR] buttons, and set on/off-type parameters, such as EQ ON/OFF. It's also used to confirm settings and enter characters when titling scene memories, effects programs, and so on. On the EQ page, the [ENTER] button is used solely to turn the EQ on and off.



## Fader Modes

The 01V [SEL], [SOLO], and [ON] buttons, channel faders, and STEREO (MASTER) fader are multifunction controls, and their exact operation depends on the selected Fader mode. Operation of these controls is shown in the following tables.

### SEL Buttons

The [SEL] buttons are used to select channels for EQ, Pan, Dynamics, and Routing operations. The following channels can be selected:

- **CH1 through CH24**—Input channels 1 through 24
- **ST**—Stereo output
- **RTN1, RTN2**—Effects returns 1 and 2
- **AUX1 through AUX4**—Aux sends 1 through 4
- **EFF1, EFF2**—Effects sends 1 and 2
- **1–16, MAS**—Remote function channels

The [SEL] buttons are also used to make and release channel pairs and fader and mute groups (“Grouping Faders” on page 55 and “Grouping Mutes” on page 56).

Fader Mode	SEL button				
	1–8 [17–24]	9–12	13/14 15/16	STEREO [MASTER]	RETURN 1/2
HOME	CH 1–16 select			STEREO OUT select	RETURN 1/2 select
AUX 1				AUX 1 master select	
AUX 2				AUX 2 master select	
AUX 3				AUX 3 master select	
AUX 4				AUX 4 master select	
EFFECT 1				EFFECT 1 master select	
EFFECT 2				EFFECT 2 master select	
OPTION I/O	CH 17–24 select	—	—	STEREO select	
REMOTE 1	Internal parameter assign select				—
REMOTE 2	MMC (1–6)	—			
REMOTE 3	User defined MIDI controller select				—

### Input Channel [SEL] button Examples

To select the EQ function for input channel 3, press the [HOME] button, and then press [SEL] button 3 (CH3 appears in the bottom right corner of the display). Use the SELECTED CHANNEL F and G controls to adjust the EQ. (If a fader mode other than Option I/O or Remote is selected, it’s not necessary to press the [HOME] button.)

To select the Pan function for input channel 13, press the [HOME] button, and then press [SEL] button 13/14 repeatedly until CH13 appears on the display. Use the SELECTED CHANNEL PAN control to adjust the pan. Since most functions on input channels 13 and 14 (likewise 15 and 16) are linked, the only time you’ll need to select these channels individually is to set the Phase or Pan. (If a fader mode other than

Option I/O or Remote is selected, it's not necessary to press the [HOME] button.)

To select the EQ function for input channel 20, press the [OPTION I/O] button, and then press [SEL] button 20 (CH20 appears on the display). Use the F and G controls to adjust the EQ.

**Master [SEL] Button Examples**

To select the stereo output, press the [HOME] button, and then press the MASTER [SEL] button (ST appears in the bottom right corner of the display).

To select the AUX 1 master, press the [AUX 1] button, and then press the MASTER [SEL] button (AUX1 appears on the display).

To select the EFFECT 1 master, press the [EFFECT 1] button, and then press the MASTER [SEL] button (EFF1 appears on the display).

**Solo Buttons**

The [SOLO] buttons are used to solo channels for monitoring. See “Solo Setup” on page 80 for more information. The following channels can be soloed:

- **CH1 through CH24**—Input channels 1 through 24
- **RTN1, RTN2**—Effects returns 1 and 2

Fader Mode	SOLO button			
	1-8 [17-24]	9-12	13/14 15/16	RETURN 1/2
HOME	CH 1-16 solo			RETURN 1/2 solo
AUX 1				
AUX 2				
AUX 3				
AUX 4				
EFFECT 1				
EFFECT 2				
OPTION I/O	CH 17-24 solo	—	—	—
REMOTE 1	—			
REMOTE 2	—			
REMOTE 3	User defined MIDI controller			—

The [SOLO] buttons 1 through 16 can be used as MIDI controllers on REMOTE page 3. See “User Defined MIDI Controllers” on page 238 for more information.

**Usage Examples**

To solo input channel 3, press the [HOME] button, and then press [SOLO] button 3. (If a fader mode other than Option I/O or Remote is selected, it's not necessary to press the [HOME] button.)

To solo input channels 13/14, press the [HOME] button, and then press [SOLO] button 13/14. (If a fader mode other than Option I/O or Remote is selected, it's not necessary to press the [HOME] button.)

To solo input channel 20, press the [OPTION I/O] button, and then press [SOLO] button 20.



## ON Buttons

The [ON] buttons are used to turn channels on or off. They work with the following channels:

- **CH1 through CH24**—Input channels 1 through 24
- **ST**—Stereo output
- **RTN1, RTN2**—Effects returns 1 and 2
- **AUX1 through AUX4**—Aux sends 1 through 4
- **EFF1, EFF2**—Effects sends 1 and 2

The bus outs can be turned on or off on PAN/ROUT page 4.

Fader Mode	ON button				
	1–8 [17–24]	9–12	13/14 15/16	STEREO [MASTER]	RETURN 1/2
HOME	CH 1–16 On/Off			STEREO OUT On/Off	RETURN 1/2 On/Off
AUX 1				AUX 1 master On/Off	
AUX 2				AUX 2 master On/Off	
AUX 3				AUX 3 master On/Off	
AUX 4				AUX 4 master On/Off	
EFFECT 1				EFFECT 1 master On/Off	
EFFECT 2				EFFECT 2 master On/Off	
OPTION I/O	CH 17–24 On/Off	—	—	STEREO OUT On/Off	
REMOTE 1	Assigned internal parameters				—
REMOTE 2	MMC (1–6)	—			
REMOTE 3	User defined MIDI controllers				—

On buttons 1 through 16 and master can be assigned to various internal parameters on REMOTE page 1, or used as MIDI controllers on REMOTE page 3. See “Assigning Faders & On Buttons” on page 194 and “User Defined MIDI Controllers” on page 238 for more information.

### Input Channel [ON] button Examples

To turn on or off input channel 3, press the [HOME] button, and then press [ON] button 3. (If a fader mode other than Option I/O or Remote is selected, it’s not necessary to press the [HOME] button.)

To turn on or off input channels 13/14, press the [HOME] button, and then press [ON] button 13/14. (If a fader mode other than Option I/O or Remote is selected, it’s not necessary to press the [HOME] button.)

To turn on or off input channel 20, press the [OPTION I/O] button, and then press [ON] button 20.

### Master [ON] Button Examples

To turn on or off the stereo output, press the [HOME] button, and then use the MASTER [ON] button.

To turn on or off the AUX 1 send master, press the [AUX 1] button, and then use the

MASTER [ON] button.

To turn on or off the EFFECT 1 send master, press the [EFFECT 1] button, and then use the MASTER [ON] button.

## Faders (plus Return Rotary Controls)

The faders are used to adjust channel levels.

Fader Mode	Fader				Rotary Control
	1-8 [17-24]	9-12	13/14 15/16	STEREO [MASTER]	RETURN 1/2
HOME	CH 1-16 level			STEREO master level	RETURN 1/2 levels
AUX 1	CH 1-16 AUX 1 send level			AUX 1 master level	RETURN 1/2 AUX 1 send levels
AUX 2	CH 1-16 AUX 2 send level			AUX 2 master level	RETURN 1/2 AUX 2 send levels
AUX 3	CH 1-16 AUX 3 send level			AUX 3 master level	RETURN 1/2 AUX 3 send levels
AUX 4	CH 1-16 AUX 4 send level			AUX 4 master level	RETURN 1/2 AUX 4 send levels
EFFECT 1	CH 1-16 EFFECT 1 send level			EFFECT 1 master level	RETURN 1 level
					<sup>1</sup> RETURN 2 EFFECT 1 send level
EFFECT 2	CH 1-16 EFFECT 2 send level			EFFECT 2 master level	<sup>2</sup> RETURN 1 EFFECT 2 send level
					RETURN 2 level
OPTION I/O	CH 17-24 level	—	—	STEREO master level	RETURN 1/2 levels
REMOTE 1	Assigned internal parameters				—
REMOTE 2	—				—
REMOTE 3	User defined MIDI controllers				—

1. Effects return 1 cannot be fed to effect send 1
2. Effects return 2 cannot be fed to effect send 2

Faders 1 through 16 and master can be assigned to various internal parameters on REMOTE page 1, or used as MIDI controllers on REMOTE page 3. See “Assigning Faders & On Buttons” on page 194 and “User Defined MIDI Controllers” on page 238 for more information.

### Input Channel Level Examples

To adjust the level of input channel 3, press the [HOME] button, and then operate fader 3.

To adjust the level of input channel 13/14, press the [HOME] button, and then operate fader 13/14.

To adjust the level of input channel 20, press the [OPTION I/O] button, and then operate fader 20.

### Input Channel Aux Send Examples

To adjust the aux 1 send level of input channel 3, press the [AUX 1] button, and then operate fader 3.

To adjust the aux 1 send level of input channel 13/14, press the [AUX 1] button, and then operate fader 13/14.

To adjust the aux 1 send level of input channel 20, use the [OPTION I/O] button to locate OPTION page 2, press [SEL] button 20, use the cursor buttons to select the AUX 1 fader, and then adjust it using the PARAMETER wheel or [-1/DEC] and [+1/INC] buttons.

*Note:* Aux send levels for input channels 17 through 24 can only be set using the virtual faders on OPTION page 2.

### **Input Channel Effects Send Examples**

To adjust the Effect 1 send level of input channel 3, press the [EFFECT 1] button, and then operate fader 3.

To adjust the Effect 1 send level of input channel 13/14, press the [EFFECT 1] button, and then operate fader 13/14.

To adjust the Effect 1 send level of input channel 20, use the [OPTION I/O] button to locate OPTION page 2, press [SEL] button 20, use the cursor buttons to select the EFFECT 1 fader, and then adjust it using the PARAMETER wheel or [-1/DEC] and [+1/INC] buttons.

*Note:* Effects send levels for input channels 17 through 24 can only be set using the virtual faders on OPTION page 2.

### **Master Level Examples**

To adjust the level of stereo out, press the [HOME] button, and then operate the MASTER fader.

To adjust the AUX 1 master send level, press the [AUX 1] button, and then operate the MASTER fader.

To adjust the EFFECT 1 master send level, press the [EFFECT 1] button, and then operate the MASTER fader.

To adjust the BUS OUT 1 master send level, use the [PAN/ROUT] button to locate PAN/ROUT page 3, use the cursor buttons to select the BUS 1 fader, and then adjust it using the PARAMETER wheel or [-1/DEC] and [+1/INC] buttons.

*Note:* Bus out master levels can only be set using the virtual faders on PAN/ROUT page 3.

## Title Edit Dialog Box

The Title Edit dialog box is used to title mix scenes, EQ programs, dynamics programs, and effects programs. Program titles can be up to 12 characters, scene memory titles up to 8 characters.



1. Use the cursor buttons to position the cursor in the title window.
2. Use the PARAMETER wheel to select characters.
3. Use the cursor buttons to select the following switches, and press the [ENTER] button to execute their functions.  
**INS**—Insert a space at the cursor position and moves subsequent characters to the right. Characters moved beyond the right edge of the title window are lost.  
**DEL**—Delete the character at the cursor position and move subsequent characters to the left.
4. Use the [+1/INC] button to enter a space at the cursor position.
5. Use the [-1/DEC] button to toggle the character at the cursor position between uppercase, lowercase, and numerals.
6. Press the [ENTER] button to store.

---

# Input Channels

---

# 5

## In this chapter...

Input Channel Overview .....	40
Phantom Powering .....	41
Pad Switches .....	41
Setting Input Channel Gain .....	41
Metering Input Channels .....	41
Changing the Input Phase .....	42
Attenuating Input Channel Signals .....	43
Applying EQ to Input Channels .....	44
Input Channels Dynamics Processors .....	44
Delaying Channel Signals .....	45
Muting Input Channels .....	46
Setting Input Channel Levels .....	46
Panning Input Channels .....	47
Routing Input Channels .....	49
Monitoring Input Channels .....	50
Input Channels & Aux Sends .....	50
Input Channels & the Omni Outs .....	50
Input Channels & the Option I/O Outs .....	50
Swapping Inputs 1–8 & 17–24 .....	51
Pairing Input Channels .....	52
Grouping Faders .....	55
Grouping Mutes .....	56
Viewing Input Channel Settings .....	57
Copying & Swapping Channel Settings .....	59
Input Channel Block Diagram .....	60

## Input Channel Overview

This section provides an overview of 01V input channels.

### Input Channels 1–12

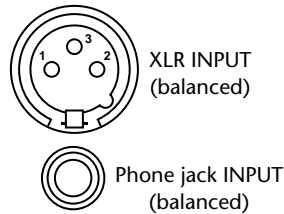

Input channels 1 through 12 feature balanced XLR-3-31-type and balanced phone jack connectors, both with a nominal input range of  $-60$  dB to  $+10$  dB. Phantom powering ( $+48$  V) is supplied to the XLR connectors, with master on/off switches for connectors 1 through 6 and 7 through 12. Phone jacks, which can also be used with unbalanced phone plugs, have priority over the XLR-type connectors, so when a phone plug is inserted, the XLR-type connector is disconnected. Inputs 1 through 8 can be swapped with inputs 17 through 24. See “Swapping Inputs 1–8 & 17–24” on page 51 for more information.

### Input Channels 13–16

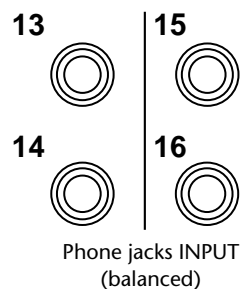

Apart from being stereo, input channels 13/14 and 15/16 offer the same features as input channels 1 through 12. Normally, the input signals for input channels 13 and 14 are derived from phone jack inputs 13 and 14. By using the CH13-14 FLIP function on PAN/ROUT page 4, however, the DIGITAL STEREO IN signals can be fed to input channels 13 and 14. See “Digital Stereo In” on page 213 for more information. Similarly, the input signals for input channels 15 and 16 are normally derived from phone jack inputs 15 and 16. By using the 15/16–2TR IN switch, however, the 2TR IN signals can be fed to input channels 15 and 16. See “Two-track Input (2TR IN)” on page 77 for more information.

### Input Channels 17–24

**OPTION I/O**

Input channels 17 through 24 do not have analog input connectors, a pad switch, gain control, or direct out. They are somewhat simpler than input channels 1 through 16 in that they feature only an attenuator, two-band parametric EQ, and can be assigned to aux sends 1 and 2, but not aux sends 3 and 4. Input channels 17 through 24 are accessed through the digital inputs of the Option I/O slot. See “About Option I/O Cards” on page 216 for more information. Inputs 17 through 24 can be swapped with inputs 1 through 8. See “Swapping Inputs 1–8 & 17–24” on page 51 for more information.

## Phantom Powering

**CH 1-6**  
ON OFF



Input channels 1 through 12 feature +48 V phantom powering for use with condenser-type microphones. Phantom powering is supplied to the balanced XLR-3-31-type connector, and can be switched for inputs 1 through 6 and inputs 7 through 12. Phantom powering should be turned on only when a condenser-type microphone is connected.

**CH 7-12**  
ON OFF



*Warning:* Make sure that phantom powering is turned off when connecting an unbalanced source to an XLR input.

## Pad Switches



Input channels 1 through 12 feature 26 dB pad switches. Input pads attenuate the input signal by 26 dB, allowing the input preamp to work with high-level signals. You may need to use a pad with “hot” signals from bass or snare drum microphones, or “hot” line-level signals. PAD switch settings are not stored in scene memories.

## Setting Input Channel Gain

GAIN controls adjust the gain of the input channel preamps. They’re used to optimize the input signal level for the best signal-to-noise performance, and should be set in conjunction with the level meters on the HOME pages. Ideally, the GAIN control should be set so that the signal level is relatively high, and it’s okay for it to reach CLIP occasionally. If CLIP is reached often, however, back off the GAIN control a little, otherwise, signal distortion may occur. The GAIN control should be set with care. If it’s set too low, the signal-to-noise performance will suffer. If it’s set too high, unpleasant signal clipping and distortion may occur.



The GAIN controls on input channels 1 through 12 are designed for use with microphone signals, and have an input sensitivity of  $-16$  dB to  $-60$  dB. Used in conjunction with the 26 dB PAD switches, however, these channels can also be used with line-level signals and “hot” microphone signals. With the pad switch on, input sensitivity is  $+10$  to  $-34$  dB. A detented action allows for accurate repeat setting.



The GAIN controls on input channels 13 through 16 are designed for use with line-level signals, and have a gain range of  $-10$  dB to  $20$  dB.

GAIN control settings are not stored in scene memories.

## Metering Input Channels

Signal levels can be metered on the HOME pages. See “Metering Signal Levels” on page 83 for more information.

## Changing the Input Phase

The Phase switches, available on input channels 1 through 16, reverse the phase of input signals by 180 degrees. This can be used to compensate for incorrectly wired balanced cables and microphones. Also, when a snare drum is miked top and bottom, the channel connected to the bottom microphone can be phase reversed to prevent signal cancellation.

1. Use the [Ø/DELAY] button to locate DELAY page 1, as shown below.

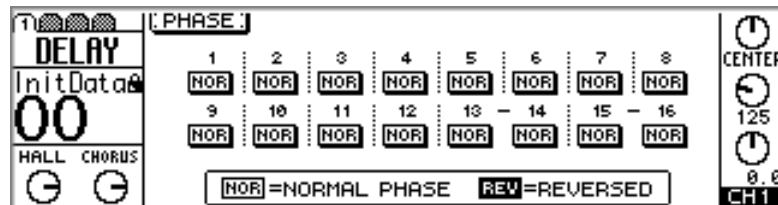

2. Use [SEL] buttons 1 through 16 to select channels.  
Phase switches can also be selected using the cursor buttons.
3. Use the [ENTER] button, or the [-1/DEC] and [+1/INC] buttons to set the phase of the selected channel to normal or reversed.

**NOR** Normal phase

**REV** Reversed phase

The Phase switches on input channels 13 and 14 (likewise 15 and 16) are not linked, and can be set independently. When input channels 1 through 12 are paired (“Pairing Input Channels” on page 52), their Phase switches continue to work independently.

Input channels 17 through 24 do not have Phase switches.



## Attenuating Input Channel Signals

Input channels 1 through 24 are fitted with digital attenuators, which can be used to attenuate input signals from 0 dB to -96 dB in 1 dB steps.

### For Input Channels 1–16

1. Use the [EQ/ATT] button to locate EQ page 1, as shown below.

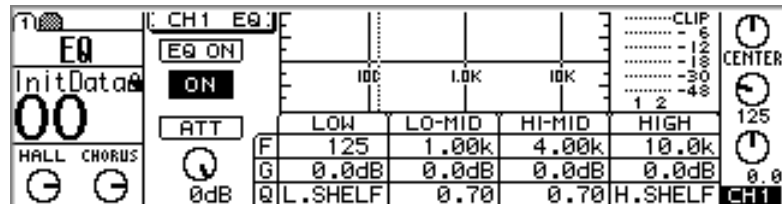

2. Use [SEL] buttons 1 through 16 to select channels.
3. Use the cursor buttons to select the ATT control, and the PARAMETER wheel or [-1/DEC] and [+1/INC] buttons to adjust it.

The Attenuation functions on input channels 13 and 14 (likewise 15 and 16) are permanently linked. When input channels 1 through 12 are paired (“Pairing Input Channels” on page 52), their attenuators are linked, so adjustments can be made with either channel selected.

The Attenuation function can be used to compensate for signal level increases caused by EQ boosting or dynamics processing. Although such signals can be reduced using the GAIN controls, doing so would adversely affect the performance of the A/D converters, which need a reasonable signal level in order to maximize signal-to-noise performance. Since the digital attenuators are located after A/D conversion, they can be used to attenuate signals without affecting performance.

### For Input Channels 17–24

1. Use the [OPTION I/O] button to locate OPTION page 2.
2. Use [SEL] buttons 17 through 24 to select channels.

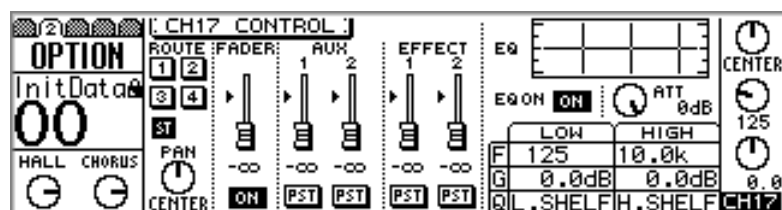

3. Use the cursor buttons to select the ATT control, and the PARAMETER wheel or [-1/DEC] and [+1/INC] buttons to adjust it.

## Applying EQ to Input Channels

Input channels 1 through 16 feature four-band parametric EQ, while input channels 17 through 24 feature two-band parametric EQ. See “EQ” on page 61 for more information. EQ can be turned on or off and the EQ curve viewed on the EQ page and VIEW page. See “Viewing Input Channel Settings” on page 57 for more information.

## Input Channels Dynamics Processors

Input channels 1 through 16 feature a dynamics processor. See “Dynamics Processors” on page 161 for more information. The dynamics can be turned on or off and the dynamics curve viewed on the Dynamics page and VIEW page. See “Viewing Input Channel Settings” on page 57 for more information.

## Delaying Channel Signals

The Channel Delays, available on input channels 1 through 16, can be used to compensate for microphone placement, or simply as delay effects. The delay parameters for input channels 1 through 8 are on DELAY page 2, while those for input channels 9 through 16 are on DELAY page 3. Both pages are shown below.

1. Use the [Ø/DELAY] button to locate DELAY page 2 or 3, as shown below.

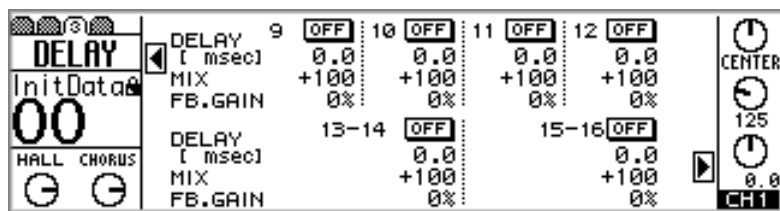
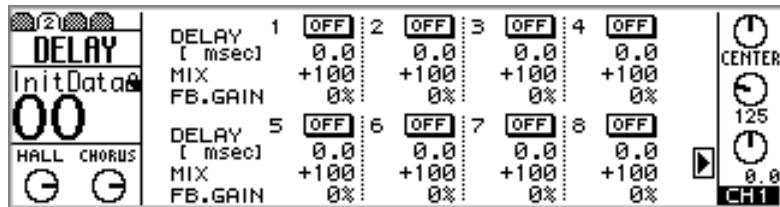

2. Use the [SEL] buttons to select channels.
3. Use the cursor buttons to select the delay parameters and the [ENTER] button, PARAMETER wheel, or [-1/DEC] and [+1/INC] buttons to set them.

Parameter	Range	Description
ON/OFF	ON/OFF	These switches are used to turn on and off the delays.
DELAY	0–250 ms	Delay can be specified in milliseconds, meters, or samples (“Setting 01V Preferences” on page 203). The maximum delay in samples is fixed at 11025. The maximum delay in milliseconds and meters depends on the sampling rate. At 44.1 kHz, for example, it is 250 milliseconds and 85.2 meters, respectively.
MIX	–100 to +100	This parameter determines the level of delayed signal. 0 is no delay. +50 is a 50/50 mix of delayed and dry signals. +100 is all delay, no dry. Negative values are the same except the delayed signal is phase reversed.
FB. GAIN	–99 to +99	This parameter determines how much of the delayed signal is fed back into the delay. 0 is no feedback. +99 is maximum feedback. Negative values are the same except the feedback signal is phase reversed.

The Channel Delays on input channels 13 and 14 (likewise 15 and 16) are permanently linked. When input channels 1 through 12 are paired (“Pairing Input Channels” on page 52), their Channel Delays are linked, so adjustments can be made with either channel selected.

## Muting Input Channels



Input channels can be turned on and off (i.e., muted) using the [ON] buttons. When a channel is on, its [ON] button lights up.

To turn on or off an input channel from 1 through 16, select a fader mode other than Option I/O or Remote, and then press an [ON] button from 1 through 16.

To turn on or off an input channel from 17 through 24, press the [OPTION I/O] button, and then press an [ON] button from 17 through 24.

The [ON] buttons on input channels 13 and 14 (likewise 15 and 16) are permanently linked. When input channels 1 through 12 are paired (“Pairing Input Channels” on page 52), their [ON] buttons are linked.

ON buttons can be grouped together for multi-channel muting using a single [ON] button. See “Grouping Mutes” on page 56 for more information.

## Setting Input Channel Levels

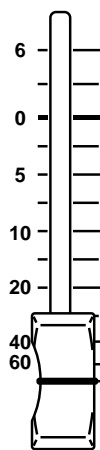

Input channel levels are controlled using the motorized 60 mm faders.

To adjust the level of an input channel from 1 through 16, press the [HOME] button, and then operate a fader from 1 through 16.

To adjust the level of an input channel from 17 through 24, press the [OPTION I/O] button, and then operate a fader from 17 through 24.

Faders operation depends on the selected Fader mode. See “Faders (plus Return Rotary Controls)” on page 35 for more information. The selected fader mode is shown on the display. See “Display” on page 28 for more information.

The faders on input channels 13 and 14 (likewise 15 and 16) are permanently linked. When input channels 1 through 12 are paired (“Pairing Input Channels” on page 52), their faders are linked.

Faders can be grouped together for multi-channel control using a single fader. See “Grouping Faders” on page 55 for more information.

## Panning Input Channels

The Panpots, available on input channels 1 through 24 (and the effects returns), are used to pan signals between the left and right channels of the stereo out, and the odd and even bus outs. Panpots can be adjusted using the SELECTED CHANNEL PAN control, the quickest method, or the panpot pages in conjunction with the cursor buttons, [-/DEC] and [+ /INC] buttons, and PARAMETER wheel.

For quick panning, select a channel and use the PAN control.

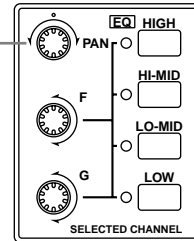

### For Input Channels 1–16 & the Effects Returns

#### 1. Use the [SEL] buttons to select channels.

To select input channel 13 or 14 (likewise 15 or 16), press [SEL] button 13/14 (15/16) repeatedly. The number of the currently selected channel appears on the display. To select the left or right channel of effects return 1 (likewise effects return 2), press [SEL] button RETURN 1 (RETURN 2) repeatedly. As these channels are selected, the letter “R” or “L” appears on the display next to the panpot icon.

#### 2. Use the PAN control to pan the selected channel.

If the PANPOT AUTO SCREEN option is turned on in the preferences (“Setting 01V Preferences” on page 203), the PAN/ROUT page shown below appears, and the Home fader mode is selected. This page can also be located using the [PAN/ROUTING] button.

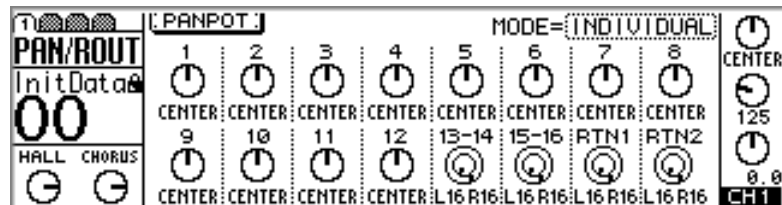

Panpots can be adjusted on this page by using the PARAMETER wheel or [-/DEC] and [+ /INC] buttons. In addition to the [SEL] buttons, panpots on the PAN/ROUT page can be selected using the cursor buttons.

### For Input Channels 17–24

1. Press the [OPTION I/O] button.
2. Use [SEL] buttons 17 through 24 to select channels.
3. Use the PAN control to pan the selected channel.

If the PANPOT AUTO SCREEN option is turned on in the preferences (“Setting 01V Preferences” on page 203), the OPTION page shown below appears. This page can also



## Routing Input Channels

The Routing switches, available on input channels 1 through 24 (and the effects returns), are used to route signals to the four bus outs, stereo out, and direct outs.

### For Input Channels 1–16 & the Effects Returns

1. Use the [PAN/ROUTING] button to locate PAN/ROUT page 2, as shown below.



2. Use the [SEL] buttons to select channels.
3. Use the cursor buttons to select the Routing switches and the [ENTER] button to set them.

### For Input Channels 17–24

1. Use the [OPTION I/O] button to locate OPTION page 2, as shown below.

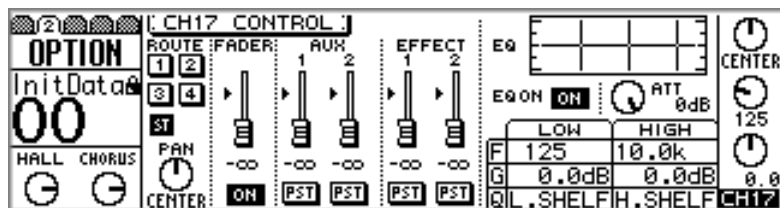

2. Use [SEL] buttons 17 through 24 to select channels.
3. Use the cursor buttons to select the Routing switches and the [ENTER] button to set them.

A highlighted Routing switch indicates that a channel has been routed.







Input channels 1 through 12 have four bus out routing switches (1, 2, 3, 4), a stereo out routing switch (ST), and a direct out routing switch (D). The latter switch is turned on automatically when an input channel is selected as the source for an Option I/O out on OPTION page 4. Likewise, when an input channel is selected as the source for an Option I/O out on OPTION page 4, the corresponding D switch on the PAN/ROUT page is turned on. See “Assigning Option I/O Digital Outputs” on page 219 for more information.



Input channels 13 through 24 (and the effects returns) have four bus out routing switches (1, 2, 3, 4) and a stereo out routing switch (ST).

Routing switches work in conjunction with Panpots to feed signals through to the left and right channels of the stereo out and the odd and even bus outs. The following table

shows how it works.

Routing	Pan	Signal Destination
	 CENTER	Signals are fed equally to bus outs 1 and 2 and the left and right channels of the stereo out.
	 L16	Signals are fed to bus out 1 and the left channel of the stereo out.
	 R16	Signals are fed to bus out 2 and the right channel of the stereo out.

The Routing switches on input channels 13 and 14 (likewise 15 and 16) are permanently linked. When input channels 1 through 12 are paired (“Pairing Input Channels” on page 52), their Routing switches are not linked.

## Monitoring Input Channels

Input channels can be monitored using the monitor out or phones. See “Monitor Setup” on page 78 for more information.

## Input Channels & Aux Sends

Signals from input channels 1 through 16 can be sent to aux sends 1 through 4, while those from input channels 17 through 24 can be sent to aux sends 1 and 2. Input channel sends can be configured as either pre-fader or post-fader sends. When aux sends are paired, aux send panpots become available on each input channel. See “Aux Sends” on page 93 for more information.

## Input Channels & the Omni Outs

Direct signals from input channels 1 through 16 can be selected for the omni outs. See “Omni Outs” on page 115 for more information. Note that OMNI OUTs are not affected by the D switches on the PAN/ROUT page 2.

## Input Channels & the Option I/O Outs

Input channels 1 through 16 can be selected as sources for the Option I/O outs. See “Routing Input Channels” on page 49 and “About Option I/O Cards” on page 216 for more information.



## Swapping Inputs 1–8 & 17–24

The inputs to channels 1 through 8 can be swapped with those of input channels 17 through 24 either individually or altogether. This allows signals from the Option I/O digital inputs to make use of the 4-band EQ, dynamics processors, and other functions of full-feature input channels 1 through 8.

1. Use the [OPTION I/O] button to locate **OPTION** page 5, as shown below.

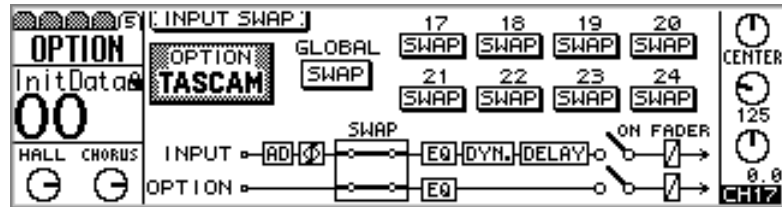

2. Use the cursor buttons to select the **GLOBAL** or individual **SWAP** switches, and the [ENTER] button, **PARAMETER** wheel, or [-1/DEC] and [+1/INC] buttons to set them.

Swap switches appear highlighted when channels are swapped.

When channels are swapped, their meter numbers appear highlighted on **HOME** page 1 and **OPTION** page 1, as shown below. When a swapped channel is selected, the selected channel area of the display alternately shows the channel number and “SWAP”, also shown below.

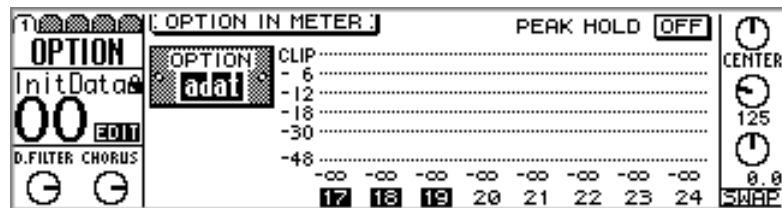
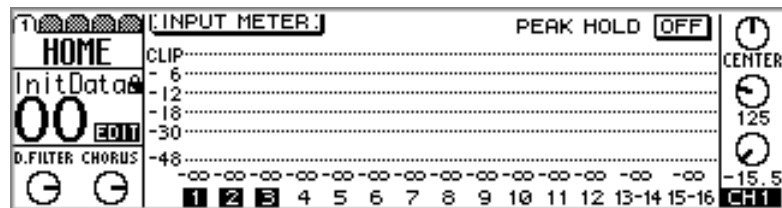

## Pairing Input Channels

Input channels 1 through 12 can be paired together for stereo signal processing. Adjacent odd and even input channels can be paired together (i.e., 1/2, 3/4, 5/6, not 2/3 or 4/5). The following parameters are linked when channels are paired: attenuators, EQ, dynamics, delays, [ON], and [SEL] buttons, faders, aux sends, effects sends, and pre/post settings. Routing switches, [SOLO] buttons, phase, panpots, aux panpots, and fade time on/off are not linked. Panpot operation depends on the selected Pan mode. See “Pan Modes” on page 48 for more information.

### Making Input Channel Pairs

1. Press the [SEL] button of both input channels simultaneously.

OR

Use the [SETUP] button to locate SETUP page 4, as shown below, and use the cursor buttons to select channel pairs, and then press the [ENTER] button.

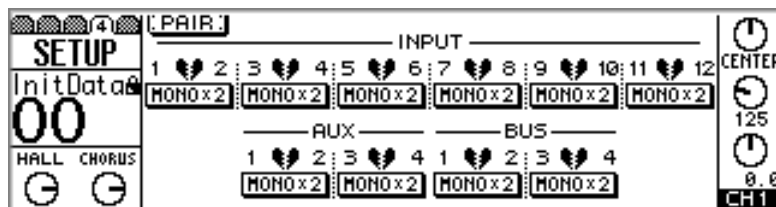

The following dialog box appears.

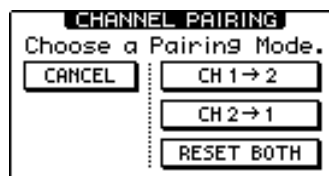

**CH 1 -> 2**—Copy the settings of input channel 1 to input channel 2.

**CH 2 -> 1**—Copy the settings of input channel 2 to input channel 1.

**RESET BOTH**—Reset both input channels to their initial settings.

2. Use the cursor buttons to select a pairing mode, and then press the [ENTER] button.

The highlighted switch and STEREO label show that the input channels are now configured as a stereo pair.



## Releasing Input Channel Pairs

1. Press the [SEL] button of both input channels simultaneously.

OR

On **SETUP** page 4, use the cursor buttons to select the paired channel switch, and then press the [ENTER] button.

The following dialog box appears.



2. Select **OK**, and then press the [ENTER] button.

The stereo pair is broken, and both input channels operate independently.

## Input Channel Pair Block Diagram

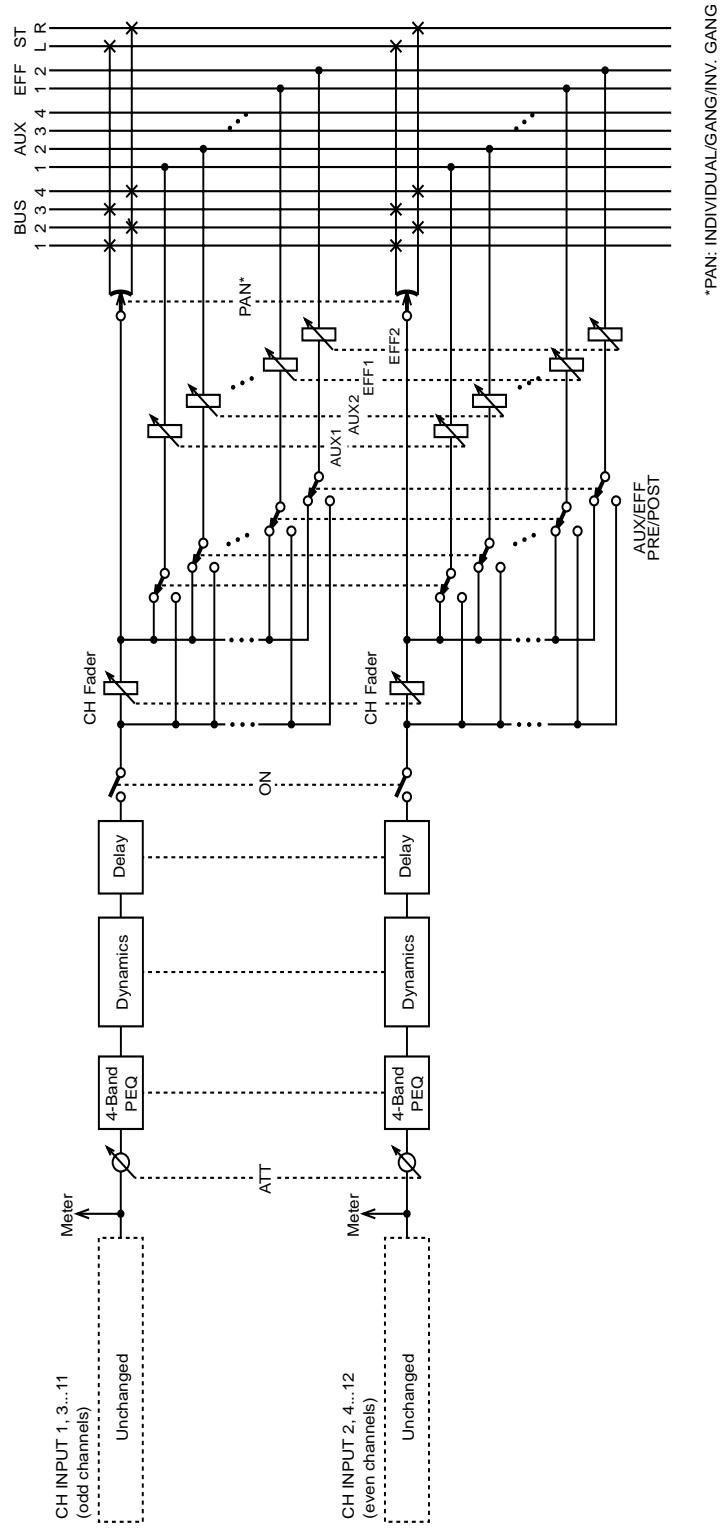

## Grouping Faders

Input channel faders 1 through 16 can be grouped together in fader groups for multi-channel control using a single fader. Three groups are available: A, B, and C.

### Making Fader Groups

1. Use the [SETUP] button to locate SETUP page 3, as shown below.

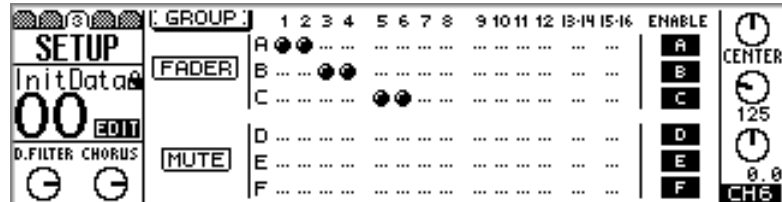

2. Use the up and down cursor buttons to select the fader groups, and the [SEL] buttons to add and remove faders to and from that group.

Channels cannot be in more than one group at a time.

Input channels 13/14, 15/16, and paired input channels 1 through 12 (“Pairing Input Channels” on page 52) are added and removed together.

Operate only one fader in a group at a time. If you attempt to adjust two or more faders in the same group, the fader motors may malfunction due to the increased load.

### Enabling & Disabling Fader Groups

Fader groups can be enabled and disabled using the ENABLE switches. Disabling a group allows you to adjust faders without removing them from the group.

1. Use the up and down cursor buttons to select the fader group that you want to disable: A, B, or C.
2. Use the [ENTER] button, PARAMETER wheel, or [-1/DEC] and [+1/INC] buttons to enable or disable the selected group.

- Fader group enabled
- Fader group disabled

## Grouping Mutes

Input channel [ON] buttons 1 through 16 can be grouped together in mute groups for multi-channel control using a single button. Three groups are available: D, E, and F. Mute groups may contain on channels and off channels, making it easy to toggle between channels. When switched, on channels go off and off channels come on.

### Making a Mute Group

1. Use the [SETUP] button to locate SETUP page 3, as shown below.

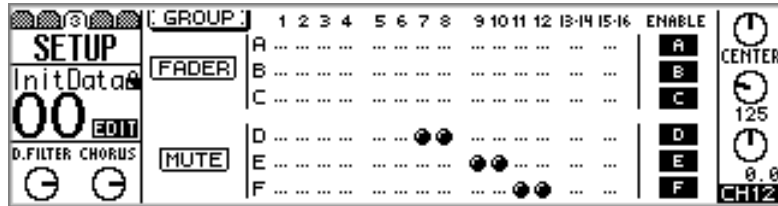

2. Use the up and down cursor buttons to select the mute groups, and the [SEL] buttons to add and remove channels to and from that group.

Channels cannot be in more than one group at a time.

Input channels 13/14, 15/16, and paired input channels 1 through 12 (“Pairing Input Channels” on page 52) are added and removed together.

### Enabling & Disabling Mute Groups

Mute groups can be enabled and disabled using the ENABLE switches. Disabling a group allows you to set channels without removing them from the group.

1. Use the up and down cursor buttons to select the mute group that you want to disable: D, E, or F.
2. Use the [ENTER] button, PARAMETER wheel, or [-1/DEC] and [+1/INC] buttons to enable or disable the selected group.

- Mute group enabled
- Mute group disabled

## Viewing Input Channel Settings

Settings for input channels 1 through 16 can be viewed, and certain parameters adjusted on VIEW pages 1 and 2. Settings for input channels 17 through 24 can be viewed and adjusted on OPTION page 2.

### Input Channels 1–16

1. Use the [VIEW] button to locate VIEW page 1 or 2

VIEW pages for input channels 1 through 12 appear as below.

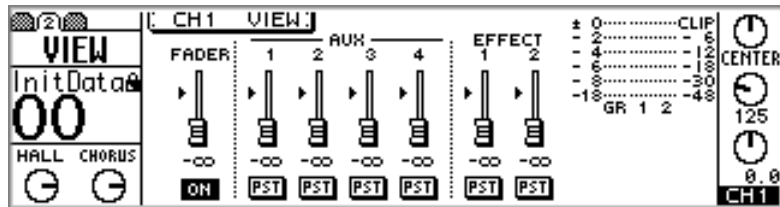
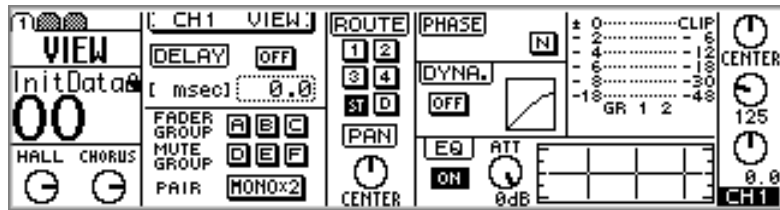

VIEW pages for input channels 13/14 and 15/16 appear as below.

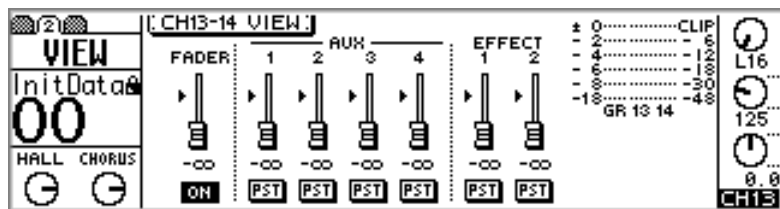
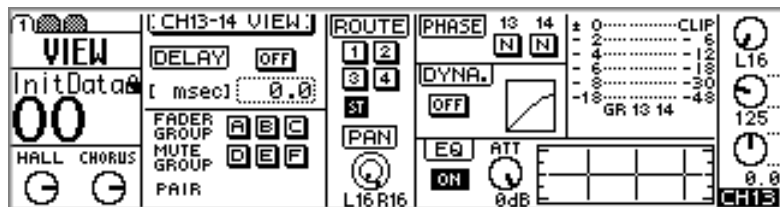

2. Use [SEL] buttons 1 through 16 to select channels.
3. Use the cursor buttons to select the parameters, and the PARAMETER wheel, [-1/DEC], [+1/INC], and [ENTER] buttons to set them.

## Input Channels 17–24

1. Use the [OPTION I/O] button to locate OPTION page 2, as shown below.

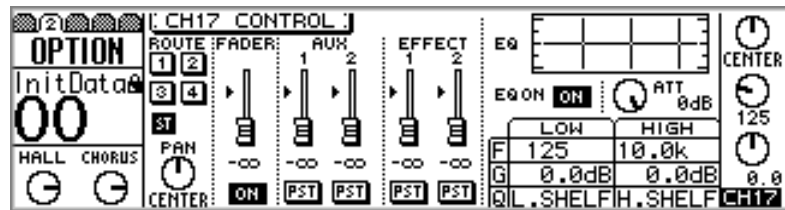

2. Use [SEL] buttons 17 through 24 to select channels.
3. Use the cursor buttons to select the parameters, and the PARAMETER wheel, [-1/DEC], [+1/INC], and [ENTER] buttons to set them.

Most of the parameters for input channels 17 through 24 can be set only on OPTION page 2.



## Copying & Swapping Channel Settings

The Channel Copy function is used to copy input channel settings from one channel to another. The Channel swap function is used to swap input channel settings between channels. Copy and Swap can be used with input channels 1 through 16.

1. Use the [VIEW] button to locate the VIEW page shown below.

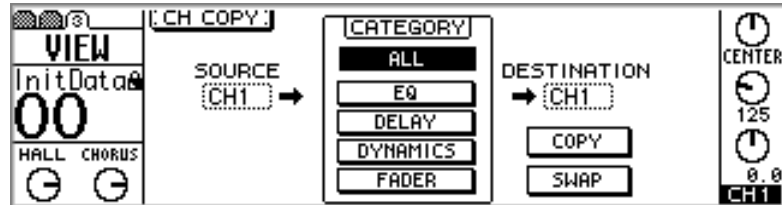

2. Use the cursor buttons and PARAMETER wheel to select the SOURCE and DESTINATION channels.
3. Use the cursor buttons and [ENTER] button to select a CATEGORY.
  - ALL—All input channel settings.
  - EQ—EQ settings.
  - DELAY—Delay settings.
  - DYNAMICS—Dynamics settings.
  - FADER—Fader settings.
4. Use the cursor buttons to select COPY or SWAP, and the [ENTER] button to execute the function.



# 6

## In this chapter...

About the 01V EQ .....	62
Adjusting the EQ .....	63
EQ Specs .....	66
Bypassing the EQ .....	66
Resetting the EQ .....	66
EQ Library .....	67
Preset EQ Program List .....	67
Storing EQ Programs .....	68
Recalling EQ Programs .....	69
Editing EQ Program Titles .....	70
Preset EQ Program Parameters .....	71

## About the 01V EQ

Input channels 1 through 16, the effects returns, aux sends, and stereo out all feature four-band parametric EQ, with variable gain, frequency, Q, and ON/OFF parameters. Input channels 17 through 24 feature a simplified two-band parametric EQ. See the “Block Diagram” on page 24 for the exact location of each EQ section. The high and low bands of each EQ can be used as shelving, peaking, or HPF (High-Pass Filter) and LPF (Low-Pass Filter), respectively.

EQ settings can be stored in the EQ library as programs, or with all mix settings in mix scenes. The EQ library consists of 40 preset programs and 40 user programs. User programs allow you to store frequently used EQ settings, which can be titled for easy identification. The unique collection of preset EQ programs are designed for specific applications and instruments, and provide a good reference and starting point when making EQ adjustments. The EQ library cannot be used with the 2-band EQs on input channels 17 through 24. See “EQ Library” on page 67 for more information.

The EQs on input channels 13 and 14 (likewise 15 and 16) are permanently linked. When input channels 1 through 12 are paired (“Pairing Input Channels” on page 52), their EQs are linked.

The EQ parameters and response curve for input channels 1 through 16, the effects returns, aux sends, and stereo out appear on the EQ page shown below.

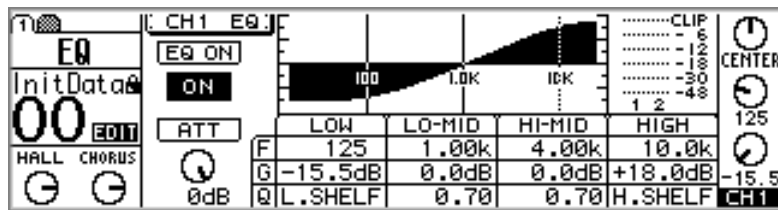

The EQ parameters and response curve for input channels 17 through 24 appear on the OPTION page shown below.

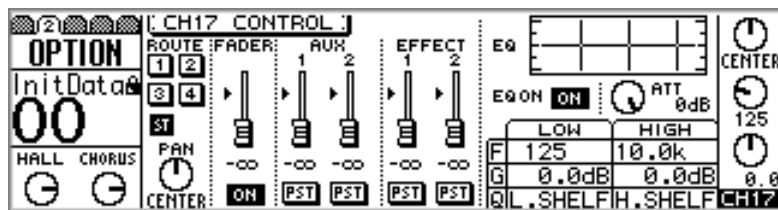

The quickest way to adjust the EQ is by using the SELECTED CHANNEL controls shown below.

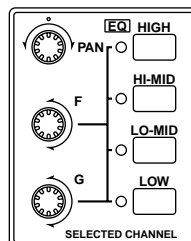

## Adjusting the EQ

EQ can be adjusted using the SELECTED CHANNEL controls, the quickest method, or the EQ pages in conjunction with the cursor buttons, [-/DEC] and [+ /INC] buttons, and PARAMETER wheel.

For quick EQ'ing select a channel and use the EQ controls.

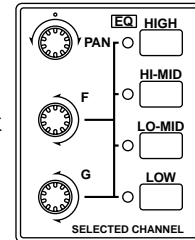

### For Input Channels 1–16

1. Use [SEL] buttons 1 through 16 to select channels.
2. Use the [HIGH], [HI-MID], [LO-MID], and [LOW] buttons to select EQ bands, and the F and G controls to adjust the frequency and gain, respectively.

If the EQ AUTO SCREEN option is turned on in the preferences (“Setting 01V Preferences” on page 203), the EQ page shown below appears, and the Home fader mode is selected. This page can also be located using the [EQ/ATT] button.

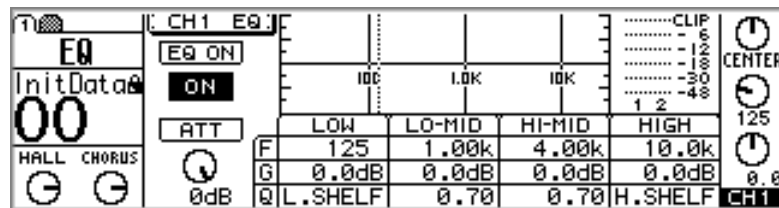

The EQ can also be adjusted on this page by using the cursor buttons to select parameters and the PARAMETER wheel or [-1/DEC] and [+1/INC] buttons to set them.

### For Input Channels 17–24

1. Press the [OPTION I/O] button.
2. Use [SEL] buttons 17 through 24 to select channels.
3. Use the [HIGH] and [LOW] buttons to select EQ bands, and the F and G controls to adjust the frequency and gain, respectively.

If the EQ AUTO SCREEN option is turned on in the preferences (“Setting 01V Preferences” on page 203), the OPTION page shown below appears. This page can also be located using the [OPTION I/O] button.

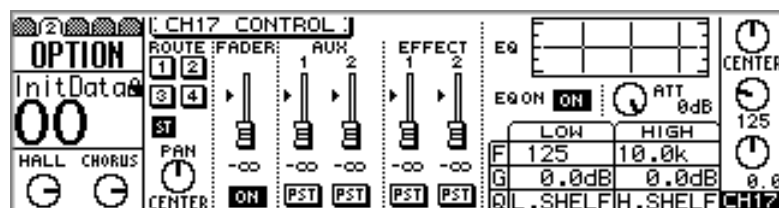

The EQ can also be adjusted on this page by using the cursor buttons to select parameters and the PARAMETER wheel or [-1/DEC] and [+1/INC] buttons to set them.

### For Effects Returns 1 & 2

1. Use the effects returns [SEL] buttons to select effects returns 1 and 2.
2. Use the [HIGH], [HI-MID], [LO-MID], and [LOW] buttons to select EQ bands, and the F and G controls to adjust the frequency and gain, respectively.

If the EQ AUTO SCREEN option is turned on in the preferences (“Setting 01V Preferences” on page 203), the EQ page shown below appears, and the Home fader mode is selected. This page can also be located using the [EQ/ATT] button.

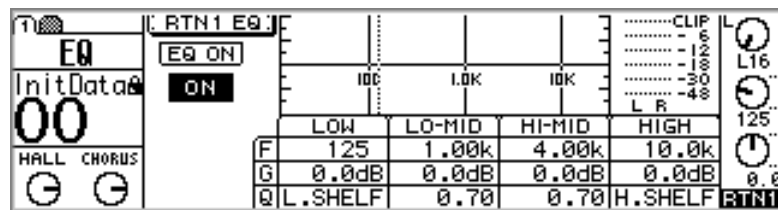

The EQ can also be adjusted on this page by using the cursor buttons to select parameters and the PARAMETER wheel or [-1/DEC] and [+1/INC] buttons to set them.

### For Aux Sends 1–4

1. Use the Fader Mode AUX buttons to select an aux send.
2. Press the MASTER [SEL] button.
3. Use the [HIGH], [HI-MID], [LO-MID], and [LOW] buttons to select EQ bands, and the F and G controls to adjust the frequency and gain, respectively.

If the EQ AUTO SCREEN option is turned on in the preferences (“Setting 01V Preferences” on page 203), the EQ page shown below appears, and the Home fader mode is selected. This page can also be located using the [EQ/ATT] button.

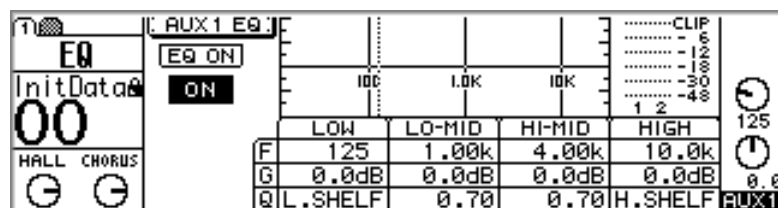

The EQ can also be adjusted on this page by using the cursor buttons to select parameters and the PARAMETER wheel or [-1/DEC] and [+1/INC] buttons to set them.

When aux sends are paired (“Pairing Aux Sends” on page 101), their EQs are linked.

## For the Stereo Output

1. Press the [HOME] button.
2. Press the MASTER [SEL] button.  
ST is the selected channel.
3. Use the [HIGH], [HI-MID], [LO-MID], and [LOW] buttons to select EQ bands, and the F and G controls to adjust the frequency and gain, respectively.

If the EQ AUTO SCREEN option is turned on in the preferences (“Setting 01V Preferences” on page 203), the EQ page shown below appears, and the Home fader mode is selected. This page can also be located using the [EQ/ATT] button.

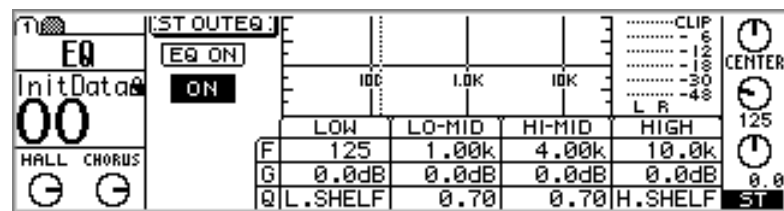

The EQ can also be adjusted on this page by using the cursor buttons to select parameters and the PARAMETER wheel or [-1/DEC] and [+1/INC] buttons to set them.

## EQ Specs

The following table contains the EQ specs.

	Low	Lo-Mid <sup>1</sup>	Hi-Mid <sup>1</sup>	High
Gain (G)	-18.0 dB to +18.0 dB (0.5 dB steps) <sup>2</sup>			
Frequency (F)	21 Hz–20.1 kHz (1/12 octave steps, 120 steps)			
Q	HPF, 10.0–0.10 (41 steps), L.SHELF	10.0–0.10 (41 steps)		LPF, 10.0–0.10 (41 steps), H.SHELF

1. Four-band EQs only (low and high bands only on input channels 17 through 24).
2. When the low and high EQ bands are configured as HPF and LPF, their gain controls function as filter on and off switches.

## Bypassing the EQ

The selected channel's EQ can be turned on or off using the EQ ON switch on the EQ page (OPTION page 2 for channels 17 through 24), or the [ENTER] button. While the EQ page is displayed, the [ENTER] button turns the EQ on or off regardless of the cursor position.



## Resetting the EQ

To reset all the EQ parameters on the selected channel to their initial values, press the [HIGH] and [LOW] buttons simultaneously.

The following table contains the initial EQ values.

	Low	Lo-Mid <sup>1</sup>	Hi-Mid <sup>1</sup>	High
Gain (G)	0 dB	0 dB	0 dB	0 dB
Frequency (F)	125 Hz	1.00 kHz	4.00 kHz	10.0 kHz
Q	L.SHELF	0.70	0.70	H.SHELF

1. Four-band EQs only (low and high bands only on input channels 17 through 24).



## EQ Library

EQ settings can be stored as programs in the EQ library, which contains 40 preset programs (1–40) and 40 user programs (41–80). User programs allow you to store frequently used EQ settings, and they can be titled for easy identification. The EQ library can also be used to transfer settings from one EQ to another. For example, the stereo out EQ settings could be stored as a library program and then recalled to an aux send EQ. The unique collection of preset EQ programs are designed for specific applications and instruments, and provide a good reference and starting point when making EQ adjustments. See page 71 for a complete list of the preset EQ programs.

The EQ library is controlled from the EQ Library page shown below. Use the [EQ/ATT] button to locate this page.

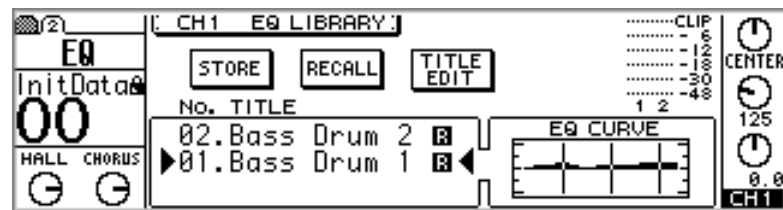

As each program is selected, its EQ curve appears in the EQ CURVE window. Above this are signal level meters for the selected channel.

## Preset EQ Program List

#	Title
01	Bass Drum 1
02	Bass Drum 2
03	Snare Drum 1
04	Snare Drum 2
05	Tom-tom 1
06	Cymbal
07	High Hat
08	Percussion
09	E.Bass 1
10	E.Bass 2
11	Syn.Bass 1
12	Syn.Bass 2
13	Piano 1
14	Piano 2
15	E.G.Clean
16	E.G.Crunch 1
17	E.G.Crunch 2
18	E.G.Dist. 1
19	E.G.Dist. 2
20	A.G.Stroke 1

#	Title
21	A.G.Stroke 2
22	A.G.Arpeg. 1
23	A.G.Arpeg. 2
24	Brass Sec.
25	Male Vocal 1
26	Male Vocal 2
27	Female Vo. 1
28	Female Vo. 2
29	Chorus&Harmo
30	Total EQ 1
31	Total EQ 2
32	Total EQ 3
33	Bass Drum 3
34	Snare Drum 3
35	Tom-tom 2
36	Piano 3
37	Piano Low
38	Piano High
39	Fine-EQ Cass
40	Narrator

## Storing EQ Programs

EQ programs are stored on the EQ Library page. You can store EQ settings to user programs 41 to 80. Preset programs 1 through 40 are read only.

1. Use the [EQ/ATT] button to locate the EQ Library page shown below.

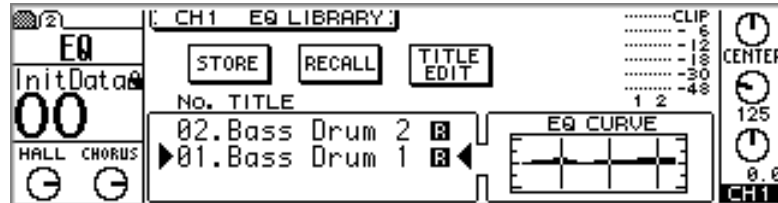

2. Use the [SEL] buttons to select the channel whose EQ settings you want to store as a program.

You can select input channels 1 through 16, the effects returns, aux sends, or stereo out. You cannot select input channels 17 through 24.

3. Use the PARAMETER wheel or [-1/DEC] and [+1/INC] buttons to select programs.

The program list order can be set using the LIBRARY LIST ORDER option in preferences (“Setting 01V Preferences” on page 203).

4. Use the cursor buttons to select STORE, and then press the [ENTER] button.

The Title Edit dialog box appears. If the STORE CONFIRMATION option is turned off in the preferences (“Setting 01V Preferences” on page 203), the Title Edit dialog box does not appear and the EQ program is stored.

5. Enter a title for the EQ program.

See “Title Edit Dialog Box” on page 37 for more information.

6. When you’ve finished, select OK, and then press the [ENTER] button.

The EQ program is stored.

## Recalling EQ Programs

EQ programs are recalled on the EQ Library page. You can recall any one of the 40 preset and 40 user programs.

1. Use the [EQ/ATT] button to locate the EQ Library page shown below.

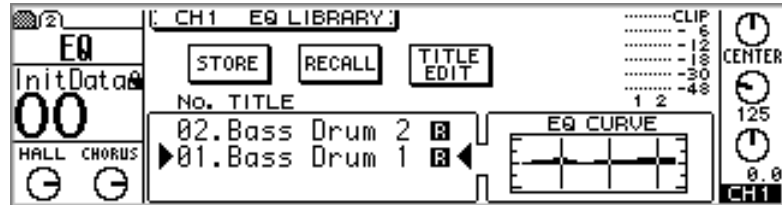

2. Use the [SEL] buttons to select the channel to which you want to recall the EQ program.

You can select input channels 1 through 16, the effects returns, aux sends, or stereo out. You cannot select input channels 17 through 24.

3. Use the PARAMETER wheel or [-1/DEC] and [+1/INC] buttons to select programs.

As each program is selected its EQ curve is displayed in the EQ CURVE window.

The program list order can be set using the LIBRARY LIST ORDER option in preferences (“Setting 01V Preferences” on page 203).

4. Use the cursor buttons to select RECALL, and then press the [ENTER] button.

The EQ program is recalled. If the RECALL CONFIRMATION option is turned on in the preferences (“Setting 01V Preferences” on page 203), a confirmation dialog box appears. In this case, select OK, and then press the [ENTER] button to confirm the recall.

## Editing EQ Program Titles

The titles of stored EQ programs can be edited using the Title Edit function.

1. Use the [EQ/ATT] button to locate the EQ Library page shown below.

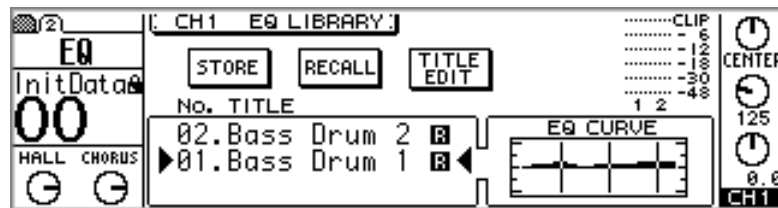

2. Use the PARAMETER wheel to select programs.
3. Use the cursor buttons to select TITLE EDIT, and then press the [ENTER] button.  
The Title Edit dialog box appears.
4. Edit the program title.  
See “Title Edit Dialog Box” on page 37 for more information.
5. When you’ve finished, select OK, and then press the [ENTER] button.  
The new title is stored.

## Preset EQ Program Parameters

#	Title	Parameter				Description	
			LOW	L-MID	H-MID		HIGH
01	Bass Drum 1		PEAKING	PEAKING	PEAKING	H.SHELF	Emphasizes the low range of a bass drum and the attack created by the beater.
		G	+3.5 dB	-3.5 dB	0.0 dB	+4.0 dB	
		F	99 Hz	265 Hz	1.05 kHz	5.33 kHz	
		Q	1.2	10	0.9	—	
02	Bass Drum 2		PEAKING	PEAKING	PEAKING	LPF	Creates a peak around 80Hz, producing a tight, stiff sound.
		G	+8.0 dB	-7.0 dB	+6.0 dB	ON	
		F	79 Hz	397 Hz	2.52 kHz	12.6 kHz	
		Q	1.4	4.5	2.2	—	
03	Snare Drum 1		PEAKING	PEAKING	PEAKING	H.SHELF	Emphasizes snapping and rimshot sounds.
		G	-0.5 dB	0.0 dB	+3.0 dB	+4.5 dB	
		F	132 Hz	1.00 kHz	3.17 kHz	5.04 kHz	
		Q	1.2	4.5	0.11	—	
04	Snare Drum 2		L.SHELF	PEAKING	PEAKING	PEAKING	Emphasizes the ranges of that classic rock snare drum sound.
		G	+1.5 dB	-8.5 dB	+2.5 dB	+4.0 dB	
		F	177 Hz	334 Hz	2.37 kHz	4.00 kHz	
		Q	—	10	0.7	0.1	
05	Tom-tom 1		PEAKING	PEAKING	PEAKING	PEAKING	Emphasizes the attack of tom-toms, and creates a long, "leathery" decay.
		G	+2.0 dB	-7.5 dB	+2.0 dB	+1.0 dB	
		F	210 Hz	667 Hz	4.49 kHz	6.35 kHz	
		Q	1.4	10	1.2	0.28	
06	Cymbal		L.SHELF	PEAKING	PEAKING	H.SHELF	Emphasizes the attack of crash cymbals, extending the "sparkling" decay.
		G	-2.0 dB	0.0 dB	0.0 dB	+3.0 dB	
		F	105 Hz	420 Hz	1.05 kHz	13.4 kHz	
		Q	—	8	0.9	—	
07	High Hat		L.SHELF	PEAKING	PEAKING	H.SHELF	Use on a tight high-hat, emphasizing the mid to high range.
		G	-4.0 dB	-2.5 dB	+1.0 dB	+0.5 dB	
		F	94 Hz	420 Hz	2.82 kHz	7.55 kHz	
		Q	—	0.5	1	—	
08	Percussion		L.SHELF	PEAKING	PEAKING	H.SHELF	Emphasizes the attack and clarifies the high-range of instruments, such as shakers, cabasas, and congas.
		G	-4.5 dB	0.0 dB	+2.0 dB	0.0 dB	
		F	99 Hz	397 Hz	2.82 kHz	16.9 kHz	
		Q	—	4.5	0.56	—	
09	E.Bass 1		L.SHELF	PEAKING	PEAKING	H.SHELF	Makes a tight electric bass sound by cutting very low frequencies.
		G	-7.5 dB	+4.5 dB	+2.5 dB	0.0 dB	
		F	35 Hz	111 Hz	2.00 kHz	4.00 kHz	
		Q	—	5	4.5	—	
10	E.Bass 2		PEAKING	PEAKING	PEAKING	H.SHELF	Unlike program 9, this program emphasizes the low range of an electric bass.
		G	+3.0 dB	0.0 dB	+2.5 dB	+0.5 dB	
		F	111 Hz	111 Hz	2.24 kHz	4.00 kHz	
		Q	0.1	5	6.3	—	

#	Title	Parameter				Description	
			LOW	L-MID	H-MID		HIGH
11	Syn.Bass 1		PEAKING	PEAKING	PEAKING	H.SHELF	Use on a synth bass with emphasized low range.
		G	+3.5 dB	+8.5 dB	0.0 dB	0.0 dB	
		F	83 Hz	944 Hz	4.00 kHz	12.6 kHz	
		Q	0.1	8	4.5	—	
12	Syn.Bass 2		PEAKING	PEAKING	PEAKING	H.SHELF	Emphasizes the attack that is peculiar to a synth bass.
		G	+2.5 dB	0.0 dB	+1.5 dB	0.0 dB	
		F	125 Hz	177 Hz	1.12 kHz	12.6 kHz	
		Q	1.6	8	2.2	—	
13	Piano 1		L.SHELF	PEAKING	PEAKING	H.SHELF	This is used to make a piano sound brighter.
		G	-6.0 dB	0.0 dB	+2.0 dB	+4.0 dB	
		F	94 Hz	944 Hz	3.17 kHz	7.55 kHz	
		Q	—	8	0.9	—	
14	Piano 2		PEAKING	PEAKING	PEAKING	H.SHELF	Used in conjunction with a compressor, this program emphasizes the attack and low range of a piano sound.
		G	+3.5 dB	-8.5 dB	+1.5 dB	+3.0 dB	
		F	223 Hz	595 Hz	3.17 kHz	5.33 kHz	
		Q	5.6	10	0.7	—	
15	E.G.Clean		PEAKING	PEAKING	PEAKING	H.SHELF	Use for line-recording an electric guitar or semi-acoustic guitar to get a slightly hard sound.
		G	+2.0 dB	-5.5 dB	+0.5 dB	+2.5 dB	
		F	265 Hz	397 Hz	1.33 kHz	4.49 kHz	
		Q	0.18	10	6.3	—	
16	E.G.Crunch 1		PEAKING	PEAKING	PEAKING	PEAKING	Adjusts the tonal quality of a slightly distorted guitar sound.
		G	+4.5 dB	0.0 dB	+4.0 dB	+2.0 dB	
		F	140 Hz	1.00 kHz	1.88 kHz	5.65 kHz	
		Q	8	4.5	0.63	9	
17	E.G.Crunch 2		PEAKING	PEAKING	PEAKING	H.SHELF	A variation on program 16.
		G	+2.5 dB	+1.5 dB	+2.5 dB	0.0 dB	
		F	125 Hz	445 Hz	3.36 kHz	19.0 kHz	
		Q	8	0.4	0.16	—	
18	E.G.Dist. 1		L.SHELF	PEAKING	PEAKING	H.SHELF	Makes a heavily distorted guitar sound clearer.
		G	+5.0 dB	0.0 dB	+3.5 dB	0.0 dB	
		F	354 Hz	944 Hz	3.36 kHz	12.6 kHz	
		Q	—	9	10	—	
19	E.G.Dist. 2		L.SHELF	PEAKING	PEAKING	H.SHELF	A variation on program 18.
		G	+6.0 dB	-8.5 dB	+4.5 dB	+4.0 dB	
		F	315 Hz	1.05 kHz	4.23 kHz	12.6 kHz	
		Q	—	10	4	—	
20	A.G.Stroke 1		PEAKING	PEAKING	PEAKING	H.SHELF	Emphasizes the bright tones of an acoustic guitar.
		G	-2.0 dB	0.0 dB	+1.0 dB	+4.0 dB	
		F	105 Hz	1.00 kHz	1.88 kHz	5.33 kHz	
		Q	0.9	4.5	3.5	—	

#	Title	Parameter				Description	
			LOW	L-MID	H-MID		HIGH
21	A.G.Stroke 2		L.SHELF	PEAKING	PEAKING	H.SHELF	A variation on program 20. You can also use it with a gutsy guitar sound.
		G	-3.5 dB	-2.0 dB	0.0 dB	+2.0 dB	
		F	297 Hz	749 Hz	2.00 kHz	3.56 kHz	
		Q	—	9	4.5	—	
22	A.G.Arpeg. 1		L.SHELF	PEAKING	PEAKING	PEAKING	Corrects arpeggio technique of an acoustic guitar.
		G	-0.5 dB	0.0 dB	0.0 dB	+2.0 dB	
		F	223 Hz	1.00 kHz	4.00 kHz	6.72 kHz	
		Q	—	4.5	4.5	0.12	
23	A.G.Arpeg. 2		L.SHELF	PEAKING	PEAKING	H.SHELF	A variation on program 22.
		G	0.0 dB	-5.5 dB	0.0 dB	+4.0 dB	
		F	177 Hz	354 Hz	4.00 kHz	4.23 kHz	
		Q	—	7	4.5	—	
24	Brass Sec.		PEAKING	PEAKING	PEAKING	PEAKING	Use with trumpets, trombones, or sax. With one instrument, adjust the HIGH or H-MID frequency.
		G	-2.0 dB	-1.0 dB	+1.5 dB	+3.0 dB	
		F	88 Hz	841 Hz	2.11 kHz	4.49 kHz	
		Q	2.8	2	0.7	7	
25	Male Vocal 1		PEAKING	PEAKING	PEAKING	PEAKING	Use as a template for male vocal. Adjust the HIGH or H-MID setting according to the voice quality.
		G	-0.5 dB	0.0 dB	+2.0 dB	+3.5 dB	
		F	187 Hz	1.00 kHz	2.00 kHz	6.72 kHz	
		Q	0.11	4.5	0.56	0.11	
26	Male Vocal 2		PEAKING	PEAKING	PEAKING	H.SHELF	A variation on program 25.
		G	+2.0 dB	-5.0 dB	-2.5 dB	+4.0 dB	
		F	167 Hz	236 Hz	2.67 kHz	6.72 kHz	
		Q	0.11	10	5.6	—	
27	Female Vo. 1		PEAKING	PEAKING	PEAKING	PEAKING	Use as a template for female vocal. Adjust the HIGH or H-MID setting according to the voice quality.
		G	-1.0 dB	+1.0 dB	+1.5 dB	+2.0 dB	
		F	118 Hz	397 Hz	2.67 kHz	5.99 kHz	
		Q	0.18	0.45	0.56	0.14	
28	Female Vo. 2		L.SHELF	PEAKING	PEAKING	H.SHELF	A variation on program 27.
		G	-7.0 dB	+1.5 dB	+1.5 dB	+2.5 dB	
		F	111 Hz	334 Hz	2.00 kHz	6.72 kHz	
		Q	—	0.16	0.2	—	
29	Chorus&Harmo		PEAKING	PEAKING	PEAKING	PEAKING	Use as a template for a chorus. It makes the entire chorus much brighter.
		G	-2.0 dB	-1.0 dB	+1.5 dB	+3.0 dB	
		F	88 Hz	841 Hz	2.11 kHz	4.49 kHz	
		Q	2.8	2	0.7	7	
30	Total EQ 1		PEAKING	PEAKING	PEAKING	H.SHELF	Use on a stereo mix during mixdown. Sounds even better when used with a compressor.
		G	-0.5 dB	0.0 dB	+3.0 dB	+6.5 dB	
		F	94 Hz	944 Hz	2.11 kHz	16.0 kHz	
		Q	7	2.2	5.6	—	

#	Title	Parameter				Description	
			LOW	L-MID	H-MID		HIGH
31	Total EQ 2		PEAKING	PEAKING	PEAKING	H.SHELF	A variation on program 30.
		G	+4.0 dB	+1.5 dB	+2.0 dB	+6.0 dB	
		F	94 Hz	749 Hz	1.78 kHz	17.9 kHz	
		Q	7	2.8	5.6	—	
32	Total EQ 3		L.SHELF	PEAKING	PEAKING	H.SHELF	A variation on program 30. Can also be used with stereo inputs or external effect returns.
		G	+1.5 dB	+0.5 dB	+2.0 dB	+4.0 dB	
		F	66 Hz	841 Hz	1.88 kHz	15.1 kHz	
		Q	—	0.28	0.7	—	
33	Bass Drum 3		PEAKING	PEAKING	PEAKING	PEAKING	A variation on program 1. The low and mid range is removed.
		G	+3.5 dB	-10.0 dB	+3.5 dB	0.0 dB	
		F	118 Hz	315 Hz	4.23 kHz	20.1 kHz	
		Q	2	10	0.4	0.4	
34	Snare Drum 3		L.SHELF	PEAKING	PEAKING	PEAKING	A variation on program 3. It creates a thick sound.
		G	0.0 dB	+2.0 dB	+3.5 dB	0.0 dB	
		F	223 Hz	561 Hz	4.23 kHz	4.00 kHz	
		Q	—	4.5	2.8	0.1	
35	Tom-tom 2		L.SHELF	PEAKING	PEAKING	H.SHELF	A variation on program 5. Emphasizes the mid and high range.
		G	-9.0 dB	+1.5 dB	+2.0 dB	0.0 dB	
		F	88 Hz	210 Hz	5.33 kHz	16.9 kHz	
		Q	—	4.5	1.2	—	
36	Piano 3		PEAKING	PEAKING	PEAKING	H.SHELF	A variation on program 13.
		G	+4.5 dB	-13.0 dB	+4.5 dB	+2.5 dB	
		F	99 Hz	472 Hz	2.37 kHz	10.0 kHz	
		Q	8	10	9	—	
37	Piano Low		PEAKING	PEAKING	PEAKING	H.SHELF	Use for the low range of a piano sound recorded in stereo.
		G	-5.5 dB	+1.5 dB	+6.0 dB	0.0 dB	
		F	187 Hz	397 Hz	6.72 kHz	12.6 kHz	
		Q	10	6.3	2.2	—	
38	Piano High		PEAKING	PEAKING	PEAKING	PEAKING	Use for the high range of a piano sound recorded in stereo.
		G	-5.5 dB	+1.5 dB	+5.0 dB	+3.0 dB	
		F	187 Hz	397 Hz	6.72 kHz	5.65 kHz	
		Q	10	6.3	2.2	0.1	
39	Fine-EQ Cass		L.SHELF	PEAKING	PEAKING	H.SHELF	Use when recording to or from cassette tape to make the sound clearer.
		G	-1.5 dB	-18.0 dB	+1.0 dB	+3.0 dB	
		F	74 Hz	1.00 kHz	4.00 kHz	12.6 kHz	
		Q	—	4.5	1.8	—	
40	Narrator		PEAKING	PEAKING	PEAKING	H.SHELF	Use when recording narration.
		G	-4.0 dB	-1.0 dB	+2.0 dB	0.0 dB	
		F	105 Hz	707 Hz	2.52 kHz	10.0 kHz	
		Q	4	7	0.63	—	



---

# Solo, Monitors & Meters

---

# 7

## In this chapter...

About Monitor & Solo .....	76
Monitor Outputs .....	77
Phones .....	77
Two-track Input (2TR IN) .....	77
Monitor Setup .....	78
Using Monitor .....	78
Monitor Block Diagram .....	79
Solo Setup .....	80
Using Solo .....	81
Solo Block Diagram .....	82
Metering Signal Levels .....	83
Main Stereo Meters .....	84
Peak Hold .....	84
Setting the Metering Point .....	85
Option I/O Meters (input channels 17–24) .....	85
Effects Send Meters .....	86

## About Monitor & Solo

Flexible monitoring and solo functions mean the 01V can be used in a wide range of applications. All inputs and outputs can be monitored pre or post fader via the monitor out or phones. Recording Solo and Mixdown Solo modes allow quick monitoring of inputs channels and effects returns. Monitor and solo parameters appear on SETUP page 2 shown below.

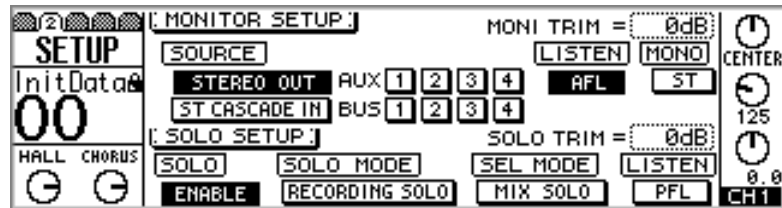

When no channels are soloed, the signal source for the monitor out and phones is selected using the MONITOR SETUP parameters in the top half of this page. Selectable sources are: the stereo output, stereo cascade in, aux sends 1 through 4, or bus outs 1 through 4. Signals can be sourced pre-fader (PFL) or post-fader (AFL). Other parameters include monitor trim and a mono/stereo switch. See “Monitor Setup” on page 78 for more information.

The SOLO SETUP parameters in the bottom half of this page are used to configure the Solo function. Input channels 1 through 24 and the effects returns can be soloed using the [SOLO] buttons. Two Solo modes are available: Recording Solo and Mixdown Solo. The SEL MODE determines how signals from each channel are soloed: individually or mixed together. Signals can be sourced pre-fader (PFL) or post-fader (AFL). Other parameters include solo trim and a solo enable switch. See “Solo Setup” on page 80 for more information.

## Monitor Outputs

Monitor and solo signals are output via the monitor out and phones connections. Make sure the MONITOR–2TR IN switch is set to MONITOR for monitoring. See “Two-track Input (2TR IN)” on page 77 for more information.

Monitor signals are converted to analog using 18-bit 8-times oversampling D/A converters, and then output via balanced 1/4-inch phone jacks with a +4 dB nominal output level.

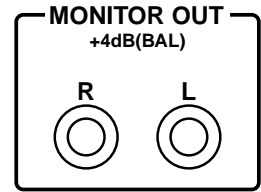

The MONITOR OUT LEVEL control is used to adjust the level of the monitor out signal.



## Phones

A pair of stereo headphones can be connected to the PHONES stereo (TRS) phone jack. The phones signal is the same as the monitor out signal.

The PHONES LEVEL control is used to adjust the level of the phones signal.



PHONES



PHONES

## Two-track Input (2TR IN)

Signals connected via the 2TR IN jacks can be monitored via the MONITOR OUT and PHONES when the MONITOR–2TR IN switch is set to 2TR IN. The stereo outputs of a master recorder can be connected here for confidence monitoring and master playback. The 2TR IN uses phono jacks with a –10 dBV nominal input level.

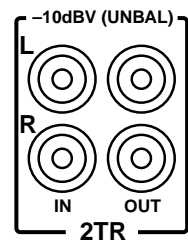

By setting the 15/16–2TR IN switch to 2TR IN, 2TR IN signals can be fed to input channels 15 and 16 for mixing with other signals. Normally, the input signals for these input channels are derived from phone jack inputs 15 and 16.

The 2TR OUT jacks are explained on page 88.

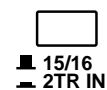

## Monitor Setup

The signal source for the monitor out and phones is selected using the MONITOR SETUP parameters on SETUP page 2. Selectable sources are: the stereo output, stereo cascade in, aux sends 1 through 4, or bus outs 1 through 4. Since the Solo function has priority, these sources can be monitored only when the Solo function is off (i.e., no channels are soloed). Signals can be sourced pre-fader (PFL) or post-fader (AFL). Other parameters include monitor trim and a mono/stereo switch.

1. Use the [SETUP] button to locate SETUP page 2 shown below.

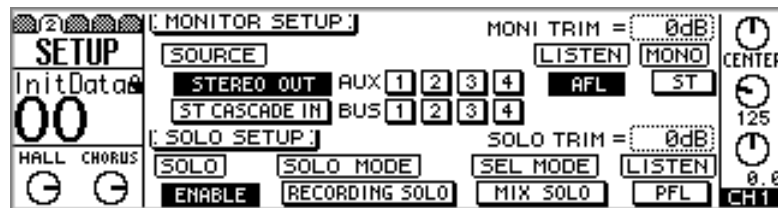

2. Use the cursor buttons to select the MONITOR SETUP parameters, and the PARAMETER wheel, [-1/DEC] and [+1/INC] buttons, and [ENTER] button to set them.

**SOURCE**—These switches are used to select the signal source for the monitor out and phones. You can select the stereo out, stereo cascade in, aux sends 1 through 4, or bus outs 1 through 4. Several sources can be selected simultaneously.

**LISTEN**—This switch sets the monitor signal source to pre-fader (PFL) or post-fader (AFL). It affects the stereo out, aux send, and bus out monitor sources. For example, when set to PFL, the stereo out can be monitored regardless of the position of the stereo master fader. When set to AFL, however, this fader must be raised in order to monitor the stereo out.

**MONI TRIM**—This parameter is used to adjust the level of the monitor signal from -60 dB to +6 dB.

**MONO**—This switch sets the monitor and phone's signals to mono (MONO) or stereo (ST). When set to MONO, the left and right signals are summed together to form a mono mix, which is attenuated by -3 dB.

## Using Monitor

To monitor, for example, the stereo out, proceed as follows.

1. **Connect a monitoring system (amp, speakers) to the MONITOR OUT.**
2. **Make sure that the MONITOR-2TR IN switch is set to MONITOR.**
3. **Set the MONITOR OUT LEVEL control midway.**  
If you are using headphones, set the PHONES LEVEL control midway.
4. **Use the [SETUP] button to locate SETUP page 2, explained previously.**
5. **Set the SOURCE to STEREO OUT.**

If MONITOR SETUP LISTEN is set to AFL, the STEREO fader must be raised. Otherwise, you won't hear anything.

# Monitor Block Diagram

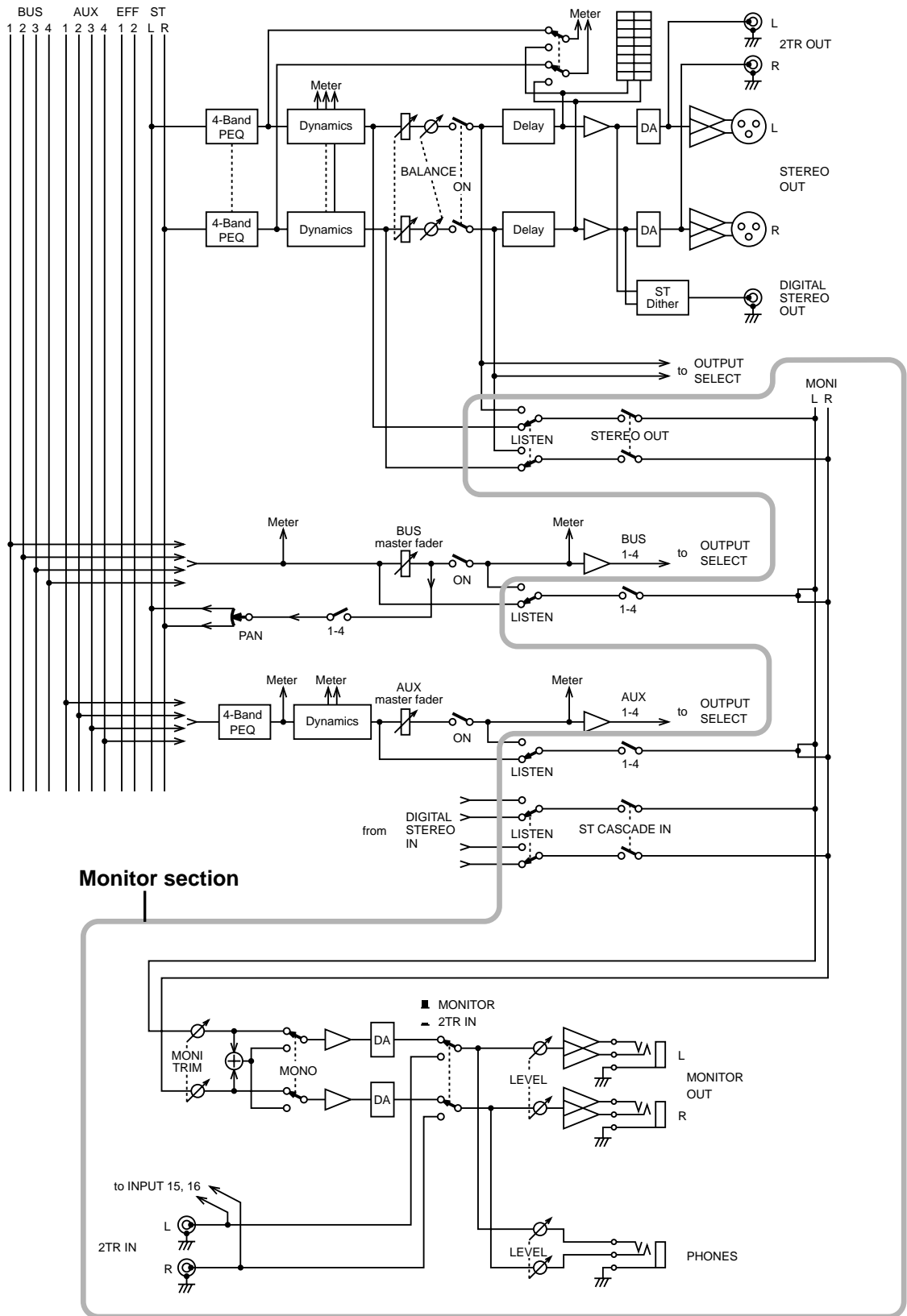

## Solo Setup

The Solo function, available on input channels 1 through 24 and the effects returns, is used to monitor channels individually. Two solo modes are available: Recording Solo and Mixdown Solo. These are configured using the SOLO SETUP parameters on SETUP page 2. Solo has priority over the sources selected using the MONITOR SETUP parameters. Channel signals can be soloed pre-fader (PFL) or post-fader (AFL). When input channels 1 through 12 are paired (“Pairing Input Channels” on page 52), their [SOLO] buttons continue to work independently.

1. Use the [SETUP] button to locate SETUP page 2 shown below.

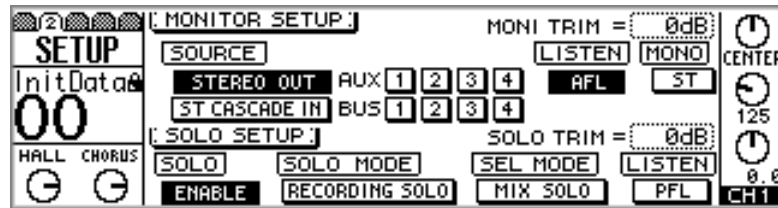

2. Use the cursor buttons to select the MONITOR SETUP parameters, and the PARAMETER wheel, [-1/DEC] and [+1/INC] buttons, and [ENTER] button to set them.

**SOLO**—This switch is used to enable and disable the Solo function. When set to DISABLE, signals are not soloed, the [SOLO] indicator on the soloed channel lights up instead of flashing, and the SOLO status indicator does not light up.

**SOLO MODE**—These switches are used to select the Solo mode: Recording Solo or Mixdown Solo.

In Recording Solo mode, Soloed channel signals are fed to the Monitor bus and then output to the monitor out and phones. No other outputs are affected. Input channels that are turned off can also be soloed. If LISTEN is set to AFL, off channels are monitored PFL. This mode is typically used to monitor individual input signals in recording and sound reinforcement applications, and is useful for checking whether signals are clipping, or making EQ adjustments in isolation.

In Mixdown Solo mode, Soloed channels signals are fed to the Stereo bus and then output to the stereo output, monitor out, and phones. Non-soloed channels are muted. Only channels that are routed to the Stereo bus can be soloed. For the purpose of soloing, channels that are turned off are turned on when soloed. This mode is typically used when adjusting individual channels during mixdown.

**SEL MODE**—These switches set the Solo Select mode. In LAST SOLO mode, only one channel can be soloed at a time. In MIX SOLO mode, however, several channels can be soloed simultaneously.

**LISTEN**—These switches set the solo signal source to pre-fader (PFL) or post-fader (AFL). It affects input channels 1 through 24 and the effects returns. This switch is not effective in Mixdown Solo mode because the monitor out and phones signals are sourced from the Stereo bus. In this mode, the MONITOR SETUP LISTEN switch can be used to select either PFL or AFL.

**SOLO TRIM**—This parameter is used to adjust the level of the solo signal from -60 dB to +6 dB.

## Using Solo

Input channels 1 through 24 and the effects returns can be soloed as follows.

1. **Connect a monitoring system (amp, speakers) to the MONITOR OUT.**
2. **Make sure that the MONITOR–2TR IN switch is set to MONITOR.**
3. **Set the MONITOR OUT LEVEL control midway.**  
If you are using headphones, set the PHONES LEVEL control midway.
4. **Use the [SETUP] button to locate SETUP page 2, explained previously, and configure as necessary.**

### For Input Channels 1–16

5. Use [SOLO] buttons 1 through 16 to solo channels.

### For Input Channels 17–24

6. Press the [OPTION I/O] button.
7. Use [SOLO] buttons 17 through 24 to solo channels.

### For Effects Returns 1 & 2

8. **Use the effects returns [SOLO] buttons to solo effects returns 1 and 2.**

When a channel is soloed, its [SOLO] button and the main SOLO indicator flash.

If SOLO SETUP LISTEN is set to AFL, you must raise the soloed channel's fader. Otherwise, you won't hear anything.







### Omni Outs

HOME page 3 displays signal level meters for the four omni outs. The source assigned to an omni out is displayed below its meters. These assignments are made on PAN/ROUT page 4. See “Assigning Omni Outs” on page 116 for more information.

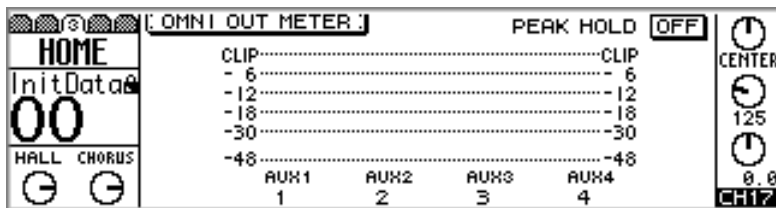

### Stereo Output

HOME page 4 displays signal level meters for the stereo output. Compared to the main stereo meters, these have a large scale from -72 dB to CLIP.

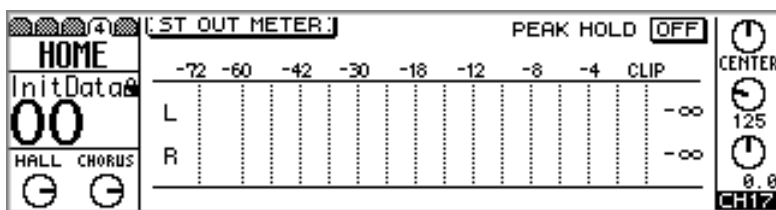

Meters for the stereo output also appear on the VIEW pages. See “Viewing Stereo Output Settings” on page 89 for more information.

### Main Stereo Meters

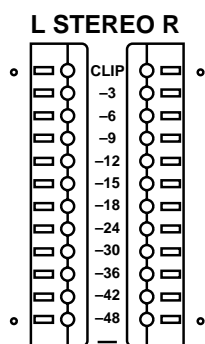

In addition to the meters on HOME page 4, stereo output levels are displayed on the dedicated 12-segment main stereo meters, with Peak Hold. The meters range from -48 dB to CLIP. If a CLIP LED does light, reduce the stereo output level to prevent signal distortion. The main stereo meters are not affected by the metering points on HOME page 5.

### Peak Hold

The Peak Hold function works with the HOME, OPTION I/O, and main stereo meters. When it's turned on, the meter segments lit by the loudest signal peaks remain on, providing an easy way to check for peak levels.

1. Use the **PARAMETER** wheel, [-1/DEC] and [+1/INC] buttons, or [ENTER] button to turn the Peak Hold function on or off.

To reset the Peak Hold function, turn it off and then on again.

## Setting the Metering Point

The metering points for input channels 1 through 16 and the effects returns can be set to either PRE EQ or PRE FADER. For the stereo output, aux send, and bus out meters it can be set to either POST EQ or POST ON. These settings do not affect the main stereo meters, which always meter POST ON signals.

1. Use the [HOME] button to locate HOME page 5, as shown below.

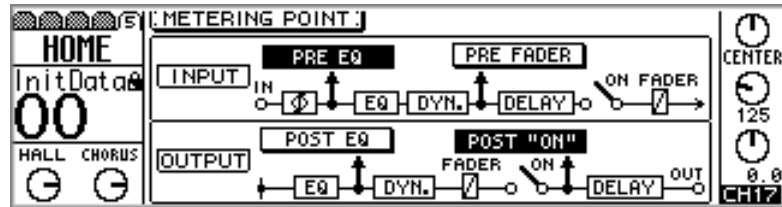

2. Use the cursor buttons to select the switches, and the PARAMETER wheel, [-1/DEC], [+1/INC], and [ENTER] buttons to set them.

**INPUT**—Used to set the meter source points for input channels 1 through 16 and the effects returns to either PRE EQ or PRE FADER.

**OUTPUT**—Used to set the meter source points for the stereo output, aux send, and bus out meters to either POST EQ or POST ON.

## Option I/O Meters (input channels 17–24)

Signal level meters for input channels 17 through 24 and the Option I/O outputs are displayed on the OPTION pages.

1. Use the [OPTION I/O] button to locate the OPTION pages.

Signal level meters for inputs 17 through 24 are displayed on OPTION page 1, as shown below. The decibel value below each meter indicates the position of the corresponding fader. The highlighted numbers 20 and 22 indicate that input channels 20 and 22 have been swapped with input channels 4 and 6. See “Swapping Inputs 1–8 & 17–24” on page 51 for more information.

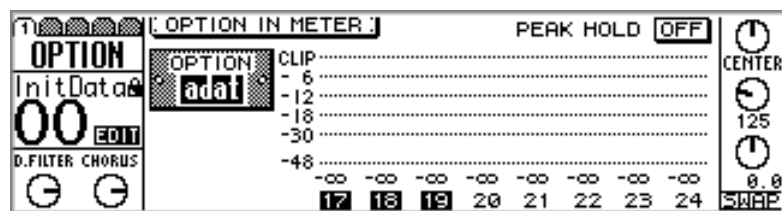

Signal level meters for the Option I/O outputs are displayed on OPTION page 3, as shown below. The source assigned to each output is displayed below its meter. These assignments are made on OPTION page 4. See “Assigning Option I/O Digital Outputs” on page 219 for more information.

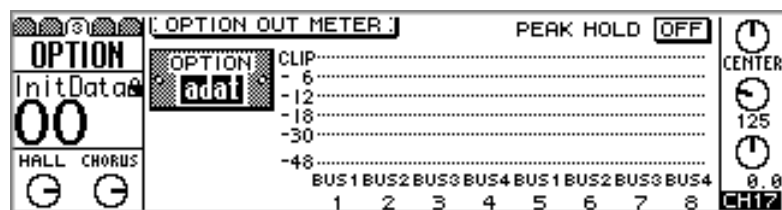

## Effects Send Meters

Signal level meters for effects sends 1 and 2 are displayed on the VIEW pages.

1. Use the [EFFECT 1] or [EFFECT 2] button to select an effects send, and then press the MASTER [SEL] button.

EFF1 or EFF2 appears on the display, indicating that an effects send is selected.

2. Use the [VIEW] button to locate VIEW pages 1 and 2, as shown below.

Signal level meters for effects send 1 are displayed on VIEW pages 1 and 2, as shown below.

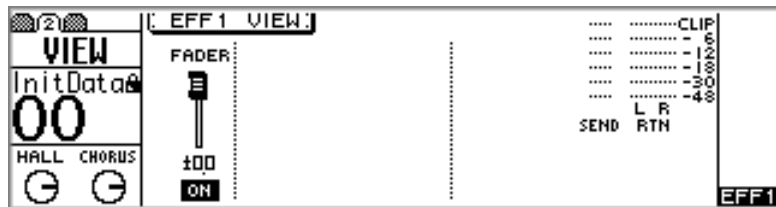
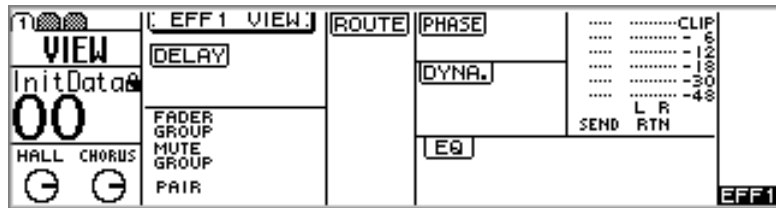

Signal level meters for effects send 2 are displayed on VIEW pages 1 and 2, as shown below.

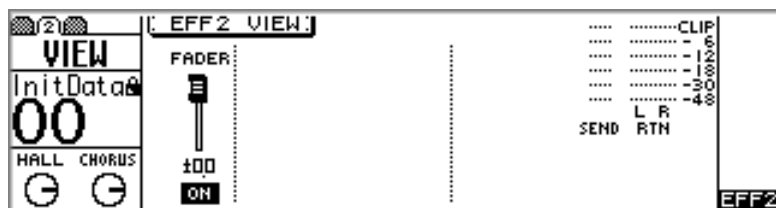
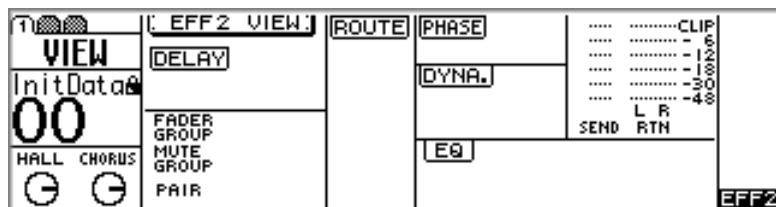

---

# Stereo Output

---

# 8

## In this chapter...

About the Stereo Output .....	88
Analog Stereo Output .....	88
2TR Out & the Stereo Output .....	88
Coaxial Digital Out & the Stereo Output .....	88
Option I/O & the Stereo Output .....	88
Omni Outs & the Stereo Output .....	88
Solo & the Stereo Output .....	88
Monitoring the Stereo Output .....	88
Metering the Stereo Output .....	89
Routing Signals to the Stereo Output .....	89
Viewing Stereo Output Settings .....	89
Setting the Stereo Output Level .....	90
Muting the Stereo Output .....	90
Balancing the Stereo Output .....	90
Applying EQ to the Stereo Output .....	90
Stereo Output Dynamics Processors .....	90
Stereo Output Delay .....	91
Stereo Output Block Diagram .....	92

## About the Stereo Output

The stereo output features four-band parametric EQ, a dynamics processor, balance control, and variable output delay of up to 300 milliseconds. The stereo signal is output via analog XLR-type connectors, analog 2TR OUT connectors, Coaxial digital outputs, and can be assigned to the Option I/O digital outputs or omni outs.

### Analog Stereo Output

The stereo output signal is converted to analog using 20-bit 8-times oversampling D/A converters, and then output via balanced XLR-3-32-type connectors with a +4 dB nominal output level.

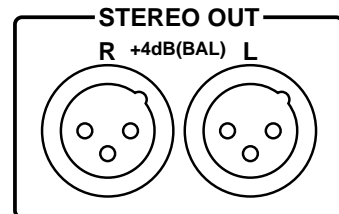

### 2TR Out & the Stereo Output

In addition to the XLR connectors, the stereo output signal is output to the 2TR OUT connectors. These are phono jacks with a –10 dBV nominal output level, and are typically connected to the analog inputs of a stereo cassette deck, DAT, or MiniDisc deck for stereo mix recording.

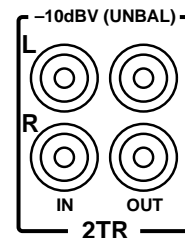

### Coaxial Digital Out & the Stereo Output

The stereo output signal is output digitally in Coaxial format from the digital stereo out connector. Typically this is connected to the digital input on a DAT or MiniDisc deck for stereo mix recording. See “Digital Stereo Out” on page 211 for more information.

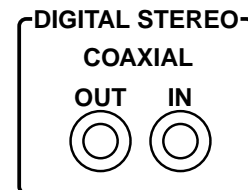

### Option I/O & the Stereo Output

The stereo output signal can be assigned to the Option I/O digital outputs. See “About Option I/O Cards” on page 216 for more information.

### Omni Outs & the Stereo Output

The stereo output signal can be assigned to the omni outs. See “Assigning Omni Outs” on page 116 for more information.

### Solo & the Stereo Output

The Mixdown Solo modes work in conjunction with the stereo output. See “Solo Setup” on page 80 for more information.

### Monitoring the Stereo Output

The stereo output can be monitored using the monitor out or phones. See “Monitor Setup” on page 78 for more information.

## Metering the Stereo Output

Stereo output signal levels can be metered using the L STEREO R meters or HOME page 4 meters. See “Metering Signal Levels” on page 83 for more information.

## Routing Signals to the Stereo Output

Input channels 1 through 24 and the effects return can be routed to the stereo output. See “Routing Input Channels” on page 49 for more information.

## Viewing Stereo Output Settings

Settings for the stereo output can be viewed, and certain parameters adjusted on VIEW pages 1 and 2.

1. Press the [HOME] button, and then the MASTER [SEL] button. ST appears on the display, indicating that the stereo output is selected.
2. Use the [VIEW] button to locate VIEW pages 1 and 2, as shown below.

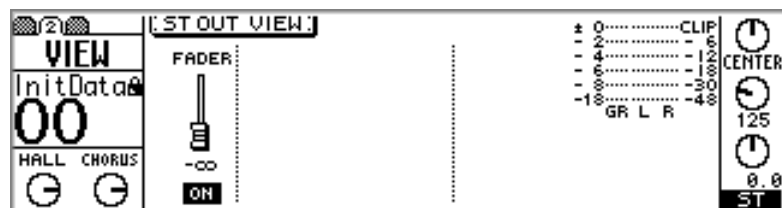
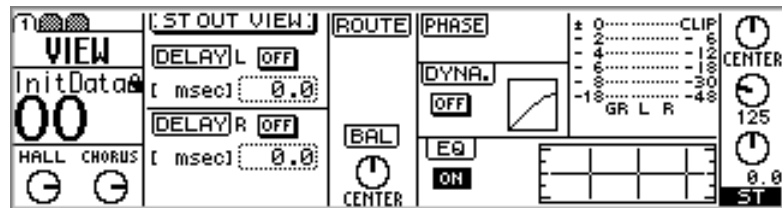

3. Use the cursor buttons to select the parameters, and the PARAMETER wheel, [-1/DEC], [+1/INC], and [ENTER] buttons to set them.

Parameters are explained in the following sections.

## Setting the Stereo Output Level

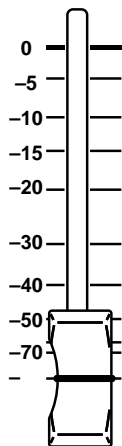

The stereo output level is controlled using the STEREO fader. Since this fader is also used to control the aux and effects send master levels, you may need to press the [HOME] button before adjusting the stereo output level. See “Faders (plus Return Rotary Controls)” on page 35 for more information.



## Muting the Stereo Output



The stereo output can be muted using the STEREO [ON] button. This button lights up when stereo output is on. Since this button is also used to mute the aux and effects send master outputs, you may need to press the [HOME] button before turning the stereo output on or off. See “ON Buttons” on page 34 for more information.

## Balancing the Stereo Output

The left and right channels of the stereo output signal can be balanced as follows.

1. **Press the [HOME] button, and then the STEREO [SEL] button.**

ST appears on the display, indicating that the stereo output is selected.

2. **Use the PAN control to adjust the balance.**

The balance can also be adjusted on the VIEW page. See “Viewing Stereo Output Settings” on page 89 for more information.

## Applying EQ to the Stereo Output

The stereo output features four-band parametric EQ. See “EQ” on page 61 for more information. The EQ can be turned on or off, and the EQ curve viewed on the VIEW page. See “Viewing Stereo Output Settings” on page 89 for more information.

## Stereo Output Dynamics Processors

The stereo output features a stereo dynamics processor. See “Dynamics Processors” on page 161 for more information. The dynamics can be turned on or off, and the dynamics curve viewed on the VIEW page. See “Viewing Stereo Output Settings” on page 89 for more information.



## Stereo Output Delay

The left and right channels of the stereo output can be delayed individually by up to 300 milliseconds. This can be used to compensate for delays in multi-speaker sound reinforcement systems.

1. Use the [Ø/DELAY] button to locate DELAY page 4, as shown below.

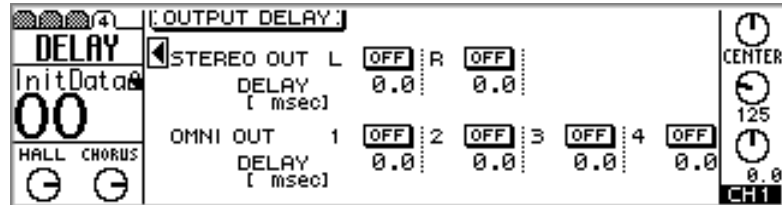

2. Use the cursor buttons to select the delay parameters and the [ENTER] button, PARAMETER wheel, or [-1/DEC] and [+1/INC] buttons to set them.

Parameter	Range	Description
ON/OFF	ON/OFF	These switches are used to turn on and off the delays.
DELAY	0–300 ms	Delay can be specified in milliseconds, meters, or samples (“Setting 01V Preferences” on page 203). The maximum delay in samples is fixed at 13229. The maximum delay in milliseconds and meters depends on the sampling rate. At 44.1 kHz, for example, it is 300 milliseconds and 102.2 meters, respectively.

# Stereo Output Block Diagram

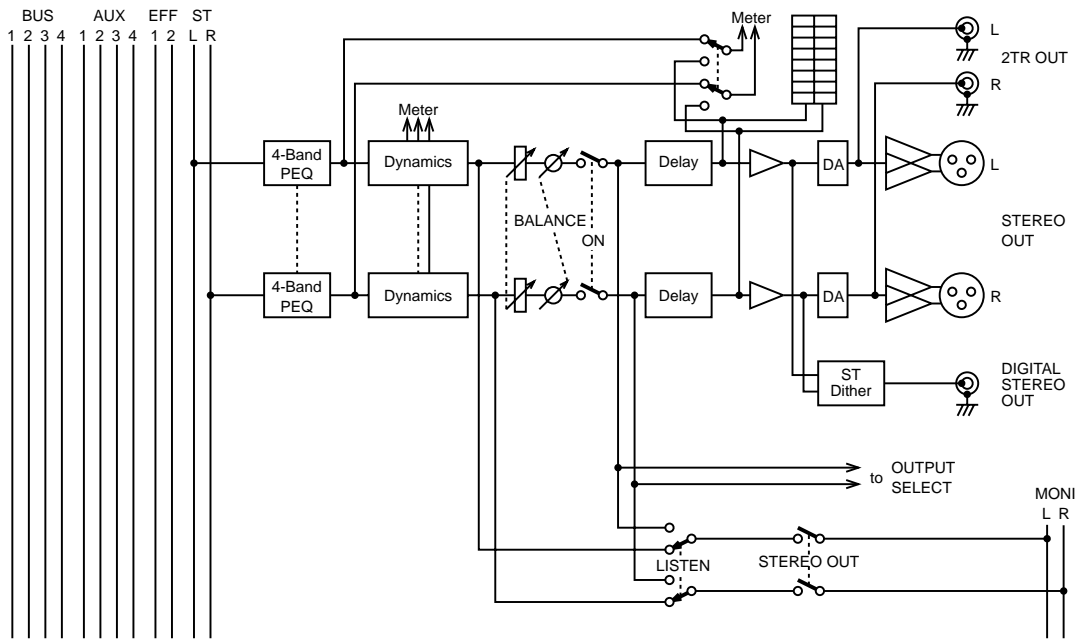

# Aux Sends

# 9

## In this chapter...

About the Aux Sends .....	94
Option I/O & the Aux Sends .....	94
Omni Outs & the Aux Sends .....	94
Monitoring Aux Sends .....	94
Metering Aux Sends .....	94
Sending Channel Signals to Aux Sends .....	95
Pre-fader/Post-fader Aux Sends .....	97
Viewing Aux Send Settings .....	98
Setting Aux Send Master Levels .....	99
Muting Aux Sends .....	100
Applying EQ to Aux Sends .....	100
Aux Send Dynamics Processors .....	100
Pairing Aux Sends .....	101
Aux Send Block Diagram .....	104
Stereo Pair Aux Send Block Diagram .....	105

## About the Aux Sends

The 01V's four aux sends, which can be used individually or in stereo pairs, feature four-band parametric EQ and dynamics processors. Signals from input channels 1 through 16 and the effects returns can be sent to aux sends 1 through 4, while those from input channels 17 through 24 can be sent to aux sends 1 and 2. Channel aux sends can be configured individually as pre-fader or post-fader sends. The 01V does not have dedicated aux send connections. Instead aux sends must be assigned to the Option I/O digital outputs or omni outs.

The 01V does not have dedicated aux return inputs. Use the input channels to return aux signals. Stereo return signals can be connected to input channels 13/14 and 15/16.

The onboard effects are explained in their own chapter. See “Effects” on page 119 for more information.

## Option I/O & the Aux Sends

Aux send signals can be assigned to the Option I/O digital outputs. See “About Option I/O Cards” on page 216 for more information.

## Omni Outs & the Aux Sends

Aux send signals can be assigned to the omni outs. See “Assigning Omni Outs” on page 116 for more information.

## Monitoring Aux Sends

Aux sends can be monitored using the monitor out or phones. See “Monitor Setup” on page 78 for more information.

## Metering Aux Sends

Aux send signal levels can be metered on the HOME pages. See “Metering Signal Levels” on page 83 for more information.

## Sending Channel Signals to Aux Sends

Signals from input channels 1 through 16 and the effects returns can be sent to aux sends 1 through 4, while those from input channels 17 through 24 can be sent to aux sends 1 and 2.

### For Input Channels 1–16

1. Use the [AUX] buttons to select an aux send.

The faders now function as channel aux send controls for the selected aux send, and an AUX page similar to the one shown below appears.

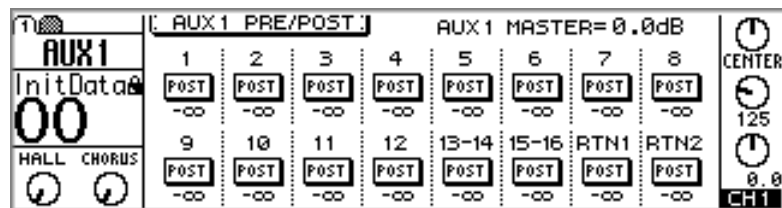

2. Raise the fader of the channel you want to send to the aux send.

If the aux send is configured post-fader (“Pre-fader/Post-fader Aux Sends” on page 97), you’ll have to raise the channel’s regular fader as well. To do this, press the [HOME] button, and then raise the fader.

The aux send controls on input channels 13 and 14 (likewise 15 and 16) are permanently linked. When input channels 1 through 12 are paired (“Pairing Input Channels” on page 52), their aux send controls are linked.

### For Input Channels 17–24

1. Use the [OPTION I/O] button to locate OPTION page 2, as shown below.

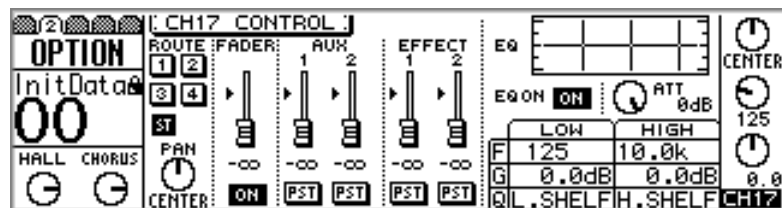

2. Use [SEL] buttons 17 through 24 to select channels.
3. Use the cursor buttons to select an AUX fader, and the PARAMETER wheel or [–1/DEC] and [+1/INC] buttons to set the send level.

If the aux send is configured post-fader (“Pre-fader/Post-fader Aux Sends” on page 97), you’ll have to raise the channel’s regular fader as well. If the Option I/O fader mode is still selected, simply raise the fader.

## For Effects Returns 1 & 2

### 1. Use the [AUX] buttons to select an aux send.

The effects returns rotary controls now function as effects returns aux send controls for the selected aux send, and an AUX page similar to the one shown below appears.

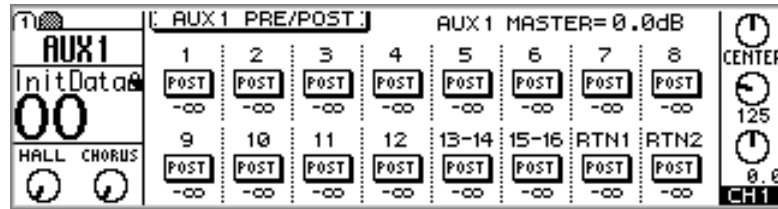

### 2. Turn up the rotary control of the effects return you want to send to the aux send.

If the aux send is configured post-fader (“Pre-fader/Post-fader Aux Sends” on page 97), you’ll have to raise the effects returns regular control as well. To do this, press the [HOME] button, and then turn up the rotary control.

## Pre-fader/Post-fader Aux Sends

The aux sends on input channels 1 through 24 and the effects returns can be configured individually as pre-fader or post-fader sends. Pre-fader means that signals are sourced before, and are not affected by the regular channel fader. Post-fader means that signals are sourced after, and are affected by the regular channel fader. With a post-fader send, the regular channel fader can be used to control the channel level and the aux send level simultaneously.

### For Input Channels 1–16 & the Effects Returns

1. Use the [AUX] buttons to locate an AUX PRE/POST page, as shown below.

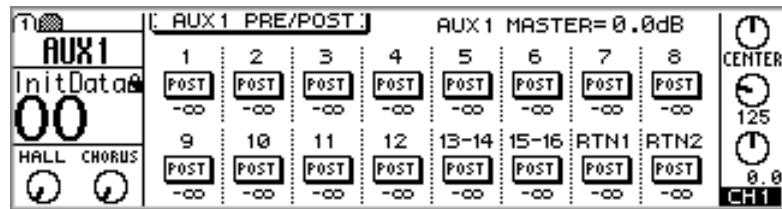

The value below each PRE/POST switch indicates the position of the aux send fader. The position of the corresponding aux send master fader is displayed at the top of the page.

2. Use the [SEL] buttons or cursor buttons to select the PRE/POST switches, and the [ENTER] button, PARAMETER wheel, or [-1/DEC] and [+1/INC] buttons to set them.

The PRE/POST switches on input channels 13 and 14 (likewise 15 and 16) are permanently linked. When input channels 1 through 12 are paired, or when aux sends are configured as stereo pairs (“Pairing Input Channels” on page 52), their PRE/POST switches are linked.

### For Input Channels 17–24

1. Use the [OPTION I/O] button to locate OPTION page 2, as shown below.

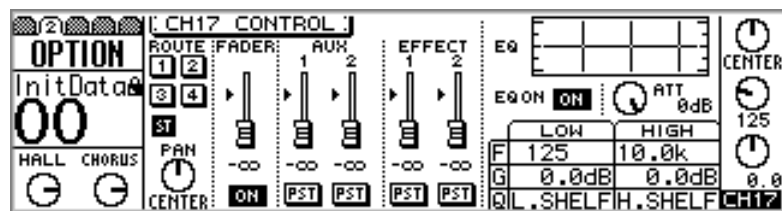

2. Use [SEL] buttons 17 through 24 to select channels.
3. Use the cursor buttons to select the AUX PRE/POST switches, and the PARAMETER wheel or [-1/DEC] and [+1/INC] buttons to set them.

When aux 1 and 2 are paired (“Pairing Aux Sends” on page 101), the PRE/POST switches are linked.

## Viewing Aux Send Settings

Settings for the aux sends can be viewed, and certain parameters adjusted on VIEW pages 1 and 2.

1. Use the [AUX] buttons to select an aux send, and then press the MASTER [SEL] button.

AUX appears on the display, indicating that an aux send is selected.

2. Use the [VIEW] button to locate VIEW pages 1 and 2, as shown below.

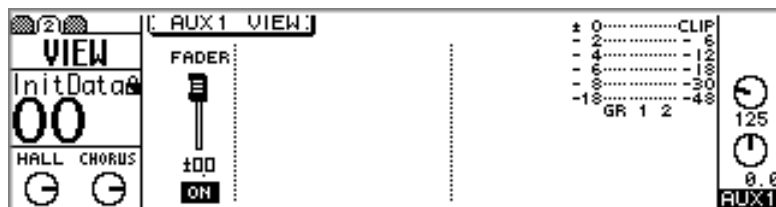
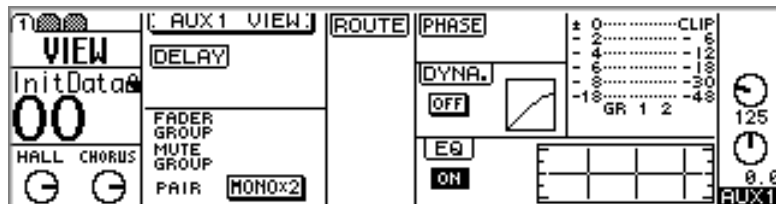

3. Use the cursor buttons to select the parameters, and the PARAMETER wheel, [-1/DEC], [+1/INC], and [ENTER] buttons to set them.

Parameters are explained in the following sections.



## Setting Aux Send Master Levels

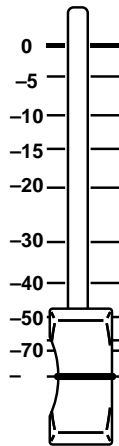

Aux send master levels are controlled using the MASTER fader. The function of this fader depends on the selected Fader mode. See “Faders (plus Return Rotary Controls)” on page 35 for more information.

**STEREO**  
MASTER

### 1. Use the [AUX] buttons to select an aux send.

An AUX page similar to the one shown below appears.

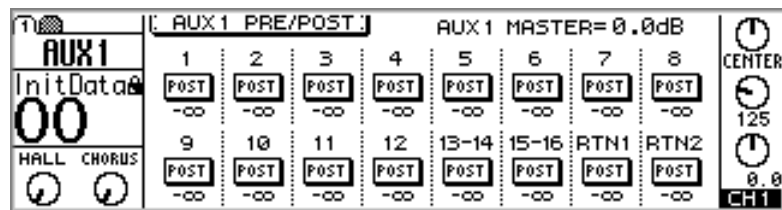

The MASTER fader now functions as aux send master level control for the selected aux send.

### 2. Use the MASTER fader to set the aux send master level.

The position of the aux send master fader is displayed at the top of the AUX PRE/POST page.

When aux sends are paired (“Pairing Aux Sends” on page 101), their master faders are linked.

The aux send master levels can be viewed and adjusted on the VIEW pages. See “Viewing Aux Send Settings” on page 98 for more information.

## Muting Aux Sends



Aux send masters can be muted using the MASTER [ON] button, which lights up when an aux send is on. The function of this button depends on the selected Fader mode. See “ON Buttons” on page 34 for more information.

1. Use the [AUX] buttons to select an aux send.

An AUX page similar to the one shown below appears.

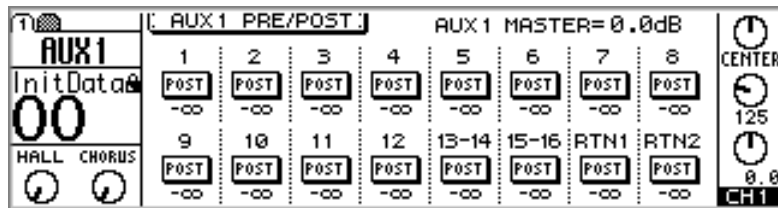

The MASTER [ON] button now functions as aux send master on/off switch for the selected aux send.

2. Use the MASTER [ON] button to turn the aux send on or off.

When aux sends are paired (“Pairing Aux Sends” on page 101), their on switches are linked.

The aux send master switches can be viewed and set on the VIEW pages. See “Viewing Aux Send Settings” on page 98 for more information.

## Applying EQ to Aux Sends

Each aux send features a four-band parametric EQ. See “EQ” on page 61 for more information. The EQ can be turned on or off, and the EQ curve viewed on the VIEW page. See “Viewing Aux Send Settings” on page 98 for more information.

## Aux Send Dynamics Processors

Each aux send features a dynamics processor. See “Dynamics Processors” on page 161 for more information. The dynamics can be turned on or off, and the dynamics curve viewed on the VIEW page. See “Viewing Aux Send Settings” on page 98 for more information.

## Pairing Aux Sends

Aux sends 1 and 2 and aux sends 3 and 4 can be paired together for stereo signal processing. When paired, the EQ, dynamics, master faders, ON buttons, and monitors of each aux send are set the same and linked for simultaneous control. In addition to the linking of aux send master parameters, pairing also affects input channels 1 through 24 and the effects returns. For these channels, aux send controls and pre/post switches are linked, and aux send panpots appear.

### Making Aux Send Pairs

1. Use the [SETUP] button to locate **SETUP** page 4, as shown below.

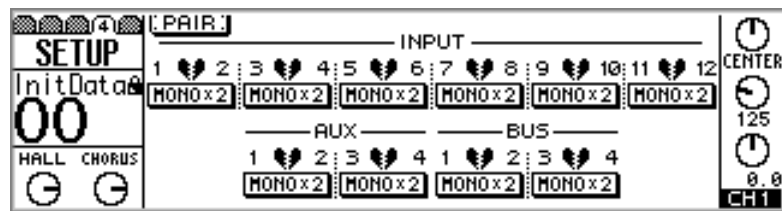

2. Use the cursor buttons to select aux pair 1/2 or 3/4, and then press the [ENTER] button.

The following dialog box appears.



**AUX 1 → 2**—Copy the settings of aux send 1 to aux send 2.

**AUX 2 → 1**—Copy the settings of aux send 2 to aux send 1.

**RESET BOTH**—Reset both aux sends to their initial settings.

3. Use the cursor buttons to select a pairing mode, and then press the [ENTER] button.

The highlighted switch and STEREO label show that the aux sends are now configured as a stereo pair.

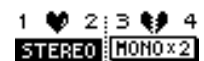

### Releasing Aux Send Pairs

1. On **SETUP** page 4, use the cursor buttons to select the paired aux switch, and then press the [ENTER] button.

The following dialog box appears.

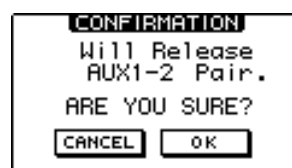

2. Select **OK**, and then press the [ENTER] button.

The stereo pair is broken, and both aux sends operate independently.

## Panning Channel Aux Sends

1. Use the [AUX 1] or [AUX 2] button to locate the AUX 1–2 Pan page, or the [AUX 3] or [AUX 4] button to locate the AUX 3–4 Pan page.

When aux sends are not paired, the AUX PAN pages are empty, as shown below.



When aux sends are paired (“Making Aux Send Pairs” on page 101), the AUX PAN pages contain panpots for input channels 1 through 16 and the effects returns, as shown below.

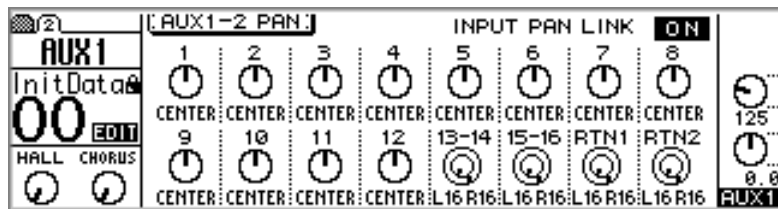

2. Use the [SEL] buttons or cursor buttons to select the channel panpots, and the PARAMETER wheel or [-1/DEC] and [+1/INC] buttons to set them.

For input channels 13/14, 15/16, and the effects returns, press the [SEL] buttons repeatedly to select the odd/left and even/right channels.

The INPUT PAN LINK option is used to link aux send panpots to their corresponding channel panpots. When this option is on, pan settings made on the AUX PAN pages are reflected on PAN/ROUT page 1 and vice versa. Also, the aux panpots are affected by the INDIVIDUAL, GANG, and INV. GANG pan modes on PAN/ROUT page 1.

Including center, there are 33 pan positions.

Hard left                      Center                      Hard right  
 L16←...←L3←L2←L1←CENTER→R1→R2→R3→...→R16



Input channels 1 through 12 feature a single panpot, as shown here.



Input channels 13/14 and 15/16 and the effects returns feature dual panpots, with the inner panpots being the odd/left channel pans and the outer panpots being the even/right channel pans. When working with stereo signals, these dual panpots can be used to adjust the width of stereo signals, as shown below.



With the inner control set at L16 and the outer control set at R16, as shown here, the width of a stereo signal is 100%.



With both controls set at CENTER, as shown here, the width of the stereo signal is zero (i.e., mono).



Setting the controls to positions in between these two extremes allows you to set the width of the stereo signal. To maintain a central balance, however, you must set both controls to corresponding values. For example, L8 and R8, or L10 and R10.

# Aux Send Block Diagram

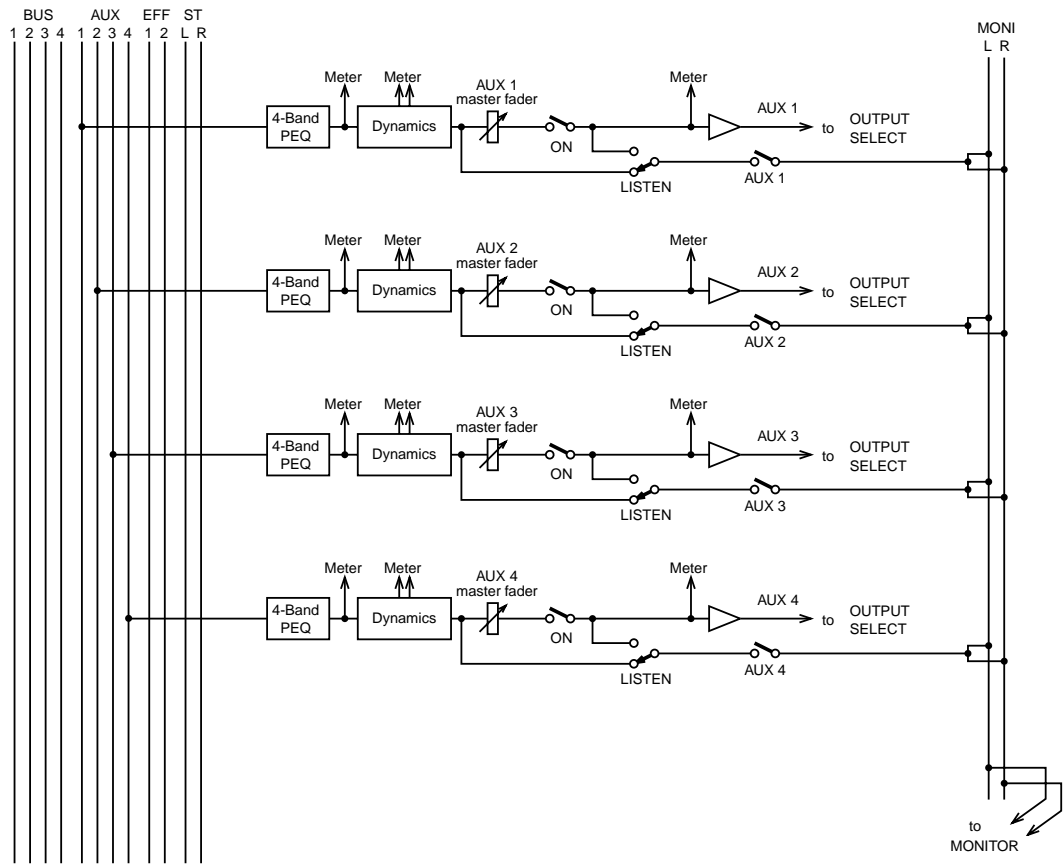

## Stereo Pair Aux Send Block Diagram

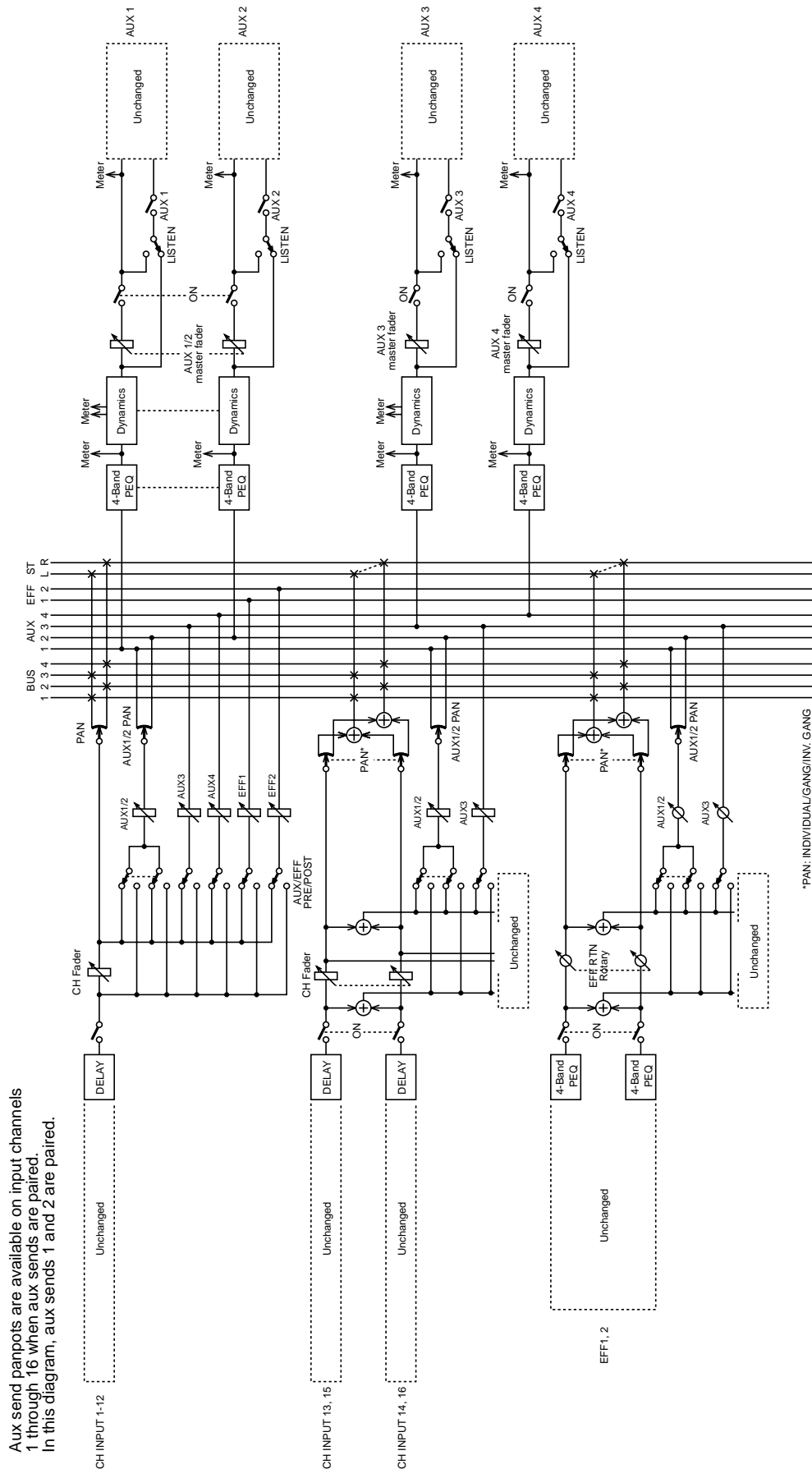

# Bus Outs

---

# 10

## In this chapter...

About the Bus Outs .....	108
Option I/O & the Bus Outs .....	108
Omni Outs & the Bus Outs .....	108
Monitoring Bus Outs .....	108
Metering Bus Outs .....	108
Routing Signals to the Bus Outs .....	108
Setting Bus Out Master Levels .....	109
Muting Bus Outs .....	109
Routing Bus Signals to the Stereo Bus .....	110
Pairing Bus Outs .....	111
Bus Out Block Diagram .....	112
Stereo Pair Bus Out Block Diagram .....	113



## About the Bus Outs

The 01V's four bus outs can be used individually or in stereo pairs. Signals from input channels 1 through 24 and the effects returns can be routed to bus outs 1 through 4. See "Routing Input Channels" on page 49 for more information. The 01V does not have dedicated bus out connections. Instead bus outs must be assigned to the Option I/O digital outputs or omni outs.

## Option I/O & the Bus Outs

Bus out signals can be assigned to the Option I/O digital outputs. See "About Option I/O Cards" on page 216 for more information.

## Omni Outs & the Bus Outs

Bus out signals can be assigned to the omni outs. See "Assigning Omni Outs" on page 116 for more information.

## Monitoring Bus Outs

Bus outs can be monitored using the monitor out or phones. See "Monitor Setup" on page 78 for more information.

## Metering Bus Outs

Bus out signal levels can be metered on the HOME pages. See "Metering Signal Levels" on page 83 for more information.

## Routing Signals to the Bus Outs

Signals from input channels 1 through 24 and the effects returns can be routed to bus outs 1 through 4. See "Routing Input Channels" on page 49 and "Routing Effects Returns" on page 131 for more information.

## Setting Bus Out Master Levels

Bus out master levels are controlled using the virtual faders on PAN/ROUT page 3.

1. Use the [PAN/ROUTING] button to locate PAN/ROUT page 3, as shown below.

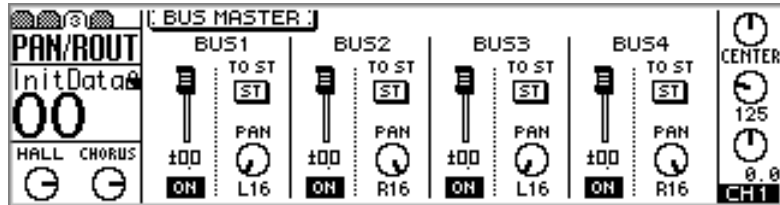

2. Use the cursor buttons to select the bus out master faders, and the PARAMETER wheel or [-1/DEC] and [+1/INC] buttons to set them.

When bus outs are paired (“Pairing Bus Outs” on page 111), their master faders are linked.

Bus out master levels can be controlled using regular faders on REMOTE page 1. See “Assigning Faders & On Buttons” on page 194 for more information.

## Muting Bus Outs

Bus outs are muted using the virtual ON switches on PAN/ROUT page 3.

1. Use the [PAN/ROUTING] button to locate PAN/ROUT page 3, as shown below.

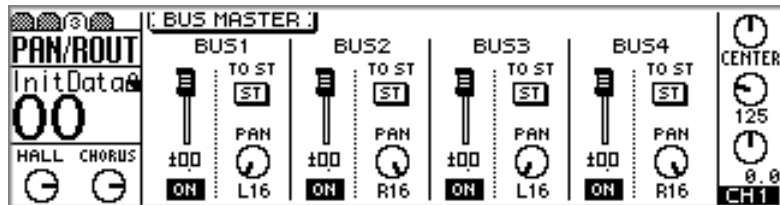

2. Use the cursor buttons to select the bus out ON switches, and the [ENTER] button, PARAMETER wheel, or [-1/DEC] and [+1/INC] buttons to set them.

When bus outs are paired (“Pairing Bus Outs” on page 111), their ON switches are linked.

Bus outs can be muted using regular [ON] buttons on REMOTE page 1. See “Assigning Faders & On Buttons” on page 194 for more information.

## Routing Bus Signals to the Stereo Bus

The bus outs can be routed to the Stereo bus and used as sub-groups during mixdown. Initially odd bus outs are panned to the left and even bus outs to right.

1. Use the [PAN/ROUTING] button to locate PAN/ROUT page 3, a shown below.

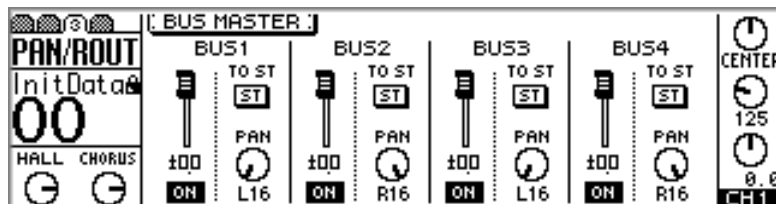

2. Use the cursor buttons to select the TO ST switches, and the [ENTER] button, PARAMETER wheel, or [-1/DEC] and [+1/INC] buttons to turn them on.
3. Use the cursor buttons to select the panpots, and the PARAMETER wheel or [-1/DEC] and [+1/INC] buttons to set them.

Including center, there are 33 pan positions.

Hard left                      Center                      Hard right  
 L16←...←L3←L2←L1←CENTER→R1→R2→R3→...→R16

## Pairing Bus Outs

Bus outs 1 and 2 and bus outs 3 and 4 can be paired together for stereo signal processing. When paired, the master faders and ON buttons are linked for simultaneous control.

### Making Bus Out Pairs

1. Use the [SETUP] button to locate SETUP page 4, as shown below.

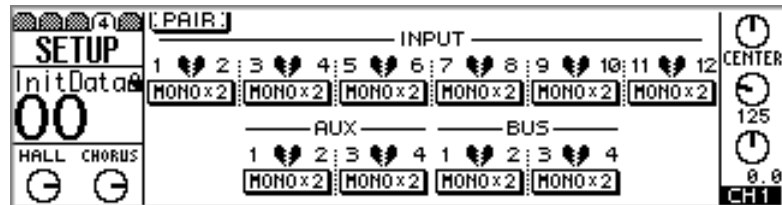

2. Use the cursor buttons to select bus pair 1/2 or 3/4, and then press the [ENTER] button.

The following dialog box appears.

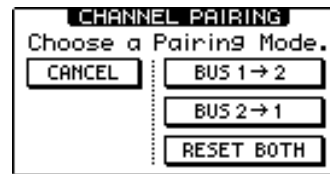

**BUS 1 -> 2**—Copy the settings of bus out 1 to bus out 2.

**BUS 2 -> 1**—Copy the settings of bus out 2 to bus out 1.

**RESET BOTH**—Reset both bus outs to their initial settings.

3. Use the cursor buttons to select a pairing mode, and then press the [ENTER] button.

The highlighted switch and STEREO label show that the bus outs are now configured as a stereo pair.

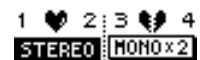

### Releasing Bus Out Pairs

1. On SETUP page 4, use the cursor buttons to select the paired bus switch, and then press the [ENTER] button.

The following dialog box appears.

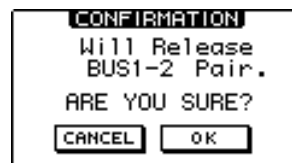

2. Select OK, and then press the [ENTER] button.

The stereo pair is broken, and both bus outs operate independently.

# Bus Out Block Diagram

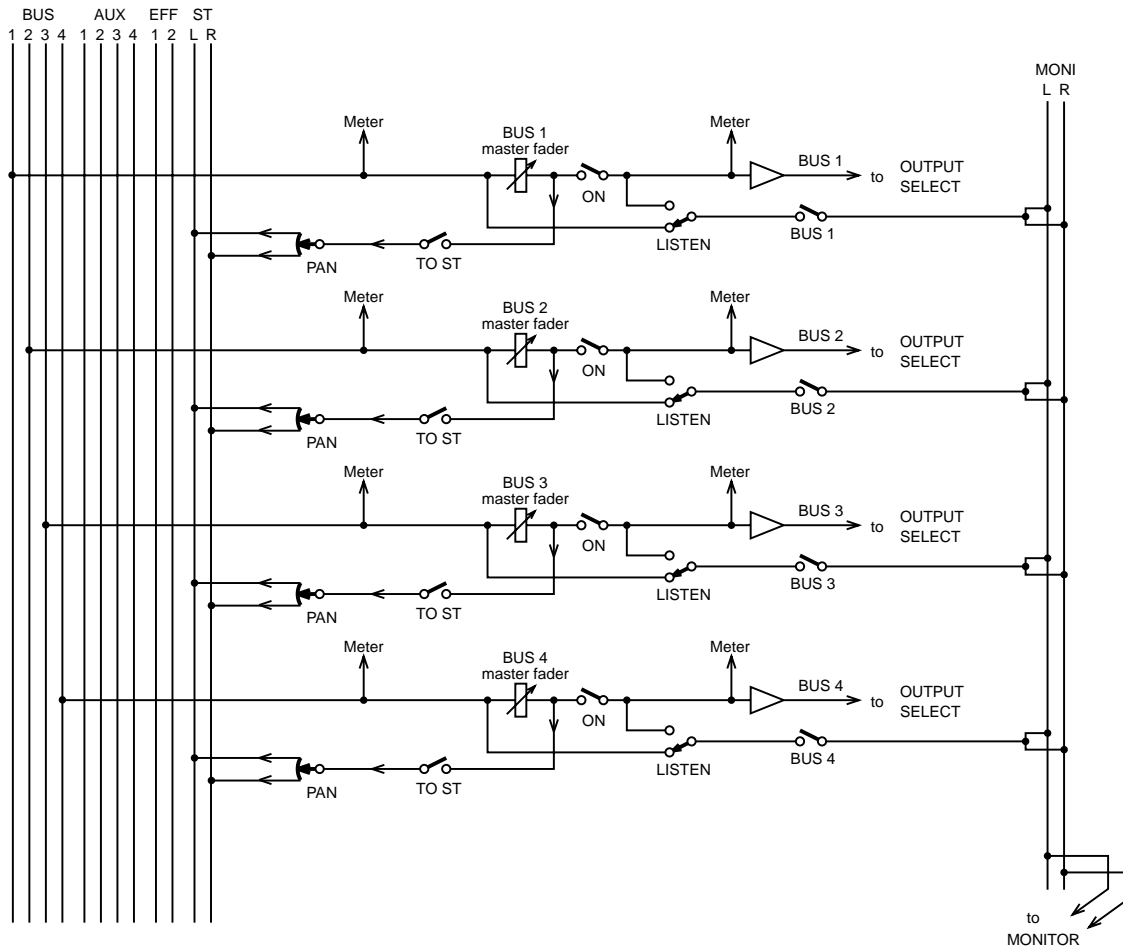

## Stereo Pair Bus Out Block Diagram

In this diagram, bus outs 1 and 2 are paired.

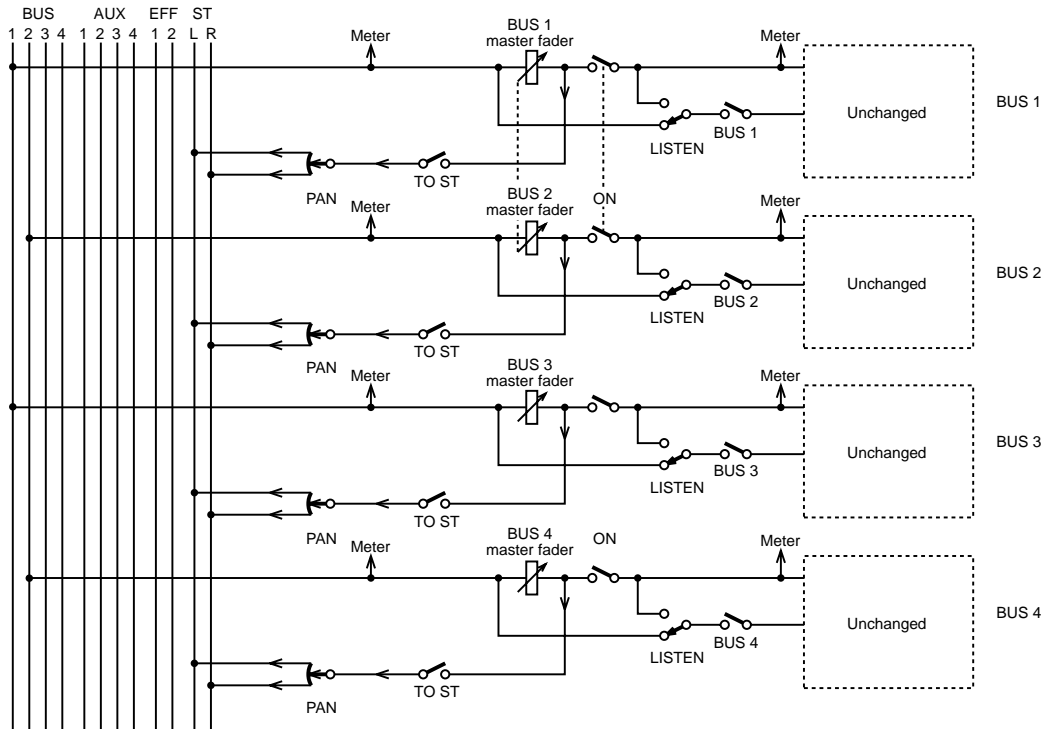

# Omni Outs

---

# 11

## In this chapter...

About the Omni Outs .....	116
Omni Outs .....	116
Assigning Omni Outs .....	116
Omni Out Delay .....	117
Omni Out Block Diagram .....	118

## About the Omni Outs

The 01V's four omni outs can be used as aux send outputs, bus out outputs, additional stereo outputs, or post-fader direct outputs for input channels 1 through 16. Each omni out features a variable output delay of up to 300 milliseconds.

## Omni Outs

Omni out signals are converted to analog using 18-bit D/A converters, and then output via balanced 1/4-inch phone jacks with a +4 dB nominal output level.

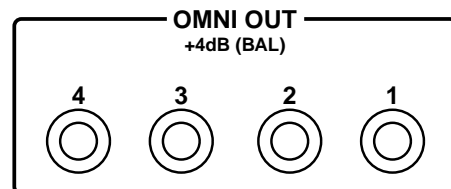

## Assigning Omni Outs

Omni outs are initially assigned to aux sends 1 through 4. They can also be assigned to the bus outs, the left and right channels of the stereo output, or post-fader direct outputs of input channels 1 through 16.

1. Use the [PAN/ROUTING] button to locate PAN/ROUT page 4, a shown below.

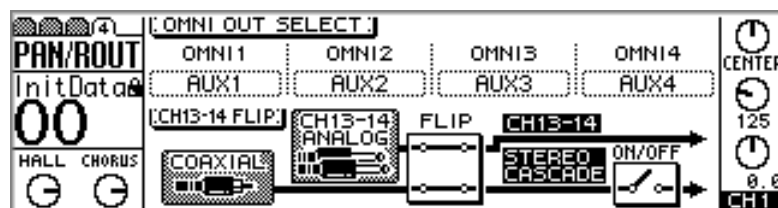

2. Use the cursor buttons to select the OMNI OUT parameter boxes, and the PARAMETER wheel or [-1/DEC] and [+1/INC] buttons to select sources for the omni outs.
3. Press the [ENTER] button to confirm your selection.



## Omni Out Delay

The omni outs can be delayed individually by up to 300 milliseconds. This can be used to compensate for delays in multi-speaker sound reinforcement systems.

1. Use the [Ø/DELAY] button to locate DELAY page 4, as shown below.

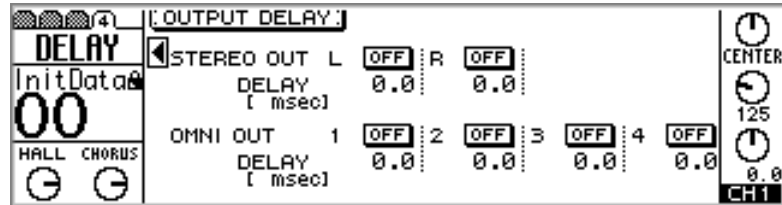

2. Use the cursor buttons to select the delay parameters and the [ENTER] button, PARAMETER wheel, or [-1/DEC] and [+1/INC] buttons to set them.

Parameter	Range	Description
ON/OFF	ON/OFF	These switches are used to turn on and off the delays.
DELAY	0–300 ms	Delay can be specified in milliseconds, meters, or samples (“Setting 01V Preferences” on page 203). The maximum delay in samples is fixed at 13229. The maximum delay in milliseconds and meters depends on the sampling rate. At 44.1 kHz, for example, it is 300 milliseconds and 102.2 meters, respectively.

## Omni Out Block Diagram

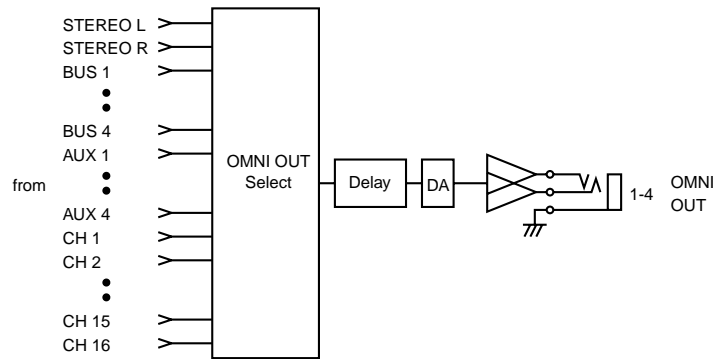

---

# Effects

---

# 12

## In this chapter...

About the Onboard Effects .....	120
Preset Effects Programs .....	121
Using the Effects .....	123
Pre-fader/Post-fader Effects Sends .....	125
Viewing Effects Send Settings .....	127
Setting Effects Send Master Levels .....	128
Metering Effects Sends .....	127
Muting Effects Sends .....	129
Viewing Effects Returns Settings .....	130
Metering Effects Returns .....	130
Applying EQ to Effects Returns .....	130
Muting Effects Returns .....	130
Setting Effects Returns Levels .....	131
Panning Effects Returns .....	131
Routing Effects Returns .....	131
Monitoring Effects Returns .....	131
Effects Returns & Aux Sends .....	131
Effects Library .....	132
Storing Effects Programs .....	133
Recalling Effects Programs .....	134
Editing Effects Program Titles .....	135
Editing Effects .....	136
Setting Delay, Freq, Note & Tempo Parameters .....	137
Effects Parameters .....	138
Effects Block Diagram .....	159

## About the Onboard Effects

The 01V's two onboard stereo multi-effects processors, Effect 1 and Effect 2, provide a wide range of high-quality effects, including reverb, delay, chorus, flange, amp simulator, and freeze. There are 42 different types of effect available. Effects processors 1 and 2 are fed by Effect buses 1 and 2, respectively, and processed signals are returned via effect returns 1 and 2. Effects can be applied to input channels 1 through 24 and the effects returns.

Effects settings are stored as programs in the effects library, which contains 42 preset programs and 57 user programs. See “Effects Library” on page 132 for more information. Effects settings are also stored in scene memories. See “Storing Mix Scenes” on page 186 for more information.

Effects processors are edited on EFFECT1 page 1, as shown below, and EFFECT2 page 2. Use the [EFFECT 1] button to locate the EFFECT1 pages and the [EFFECT 2] button to locate the EFFECT2 pages. When EFFECT1 pages are selected, the effects return 1 level icon is highlighted, as shown below. When EFFECT2 pages are selected, the effects return 2 level icon is highlighted.



The title of the selected program and the type of effect it uses appear at the top of the page. Below these are the effects parameters, the number of which vary depending on the type of effect selected. The type of effect is displayed above the effects returns level control icons. On this page, Effect 1 is using a HALL reverb, while Effect 2 is using a CHORUS effect. Up and down arrow icons, like the down icon on this page, indicate that more parameters are available and can be selected using the up and down cursor buttons. The meters indicate effects returns signal levels for the selected effects processor.

## Preset Effects Programs

The following table lists the preset effects programs. See “Effects Parameters” on page 138 for detailed parameter information. Effects programs that use the HQ, PITCH or FREEZE type effects can be used only with Effect 2.

### Reverb-type Effects

#	Title	Type	Description
01	Reverb Hall	REVERB HALL	Reverb simulating a large space such as a concert hall.
02	Reverb Room	REVERB ROOM	Reverb simulating the acoustics of a smaller space (room) than REVERB HALL.
03	Reverb Stage	REVERB STAGE	Reverb designed with vocals in mind.
04	Reverb Plate	REVERB PLATE	Simulation of a metal-plate reverb unit, producing a feeling of hard-edged reverberation.
05	Early Ref.	EARLY REF.	An effect which isolates only the early reflection (ER) component from reverberation. A flashier effect than reverb is produced.
06	Gate Reverb	GATE REVERB	A type of ER designed for use as gated reverb.
07	Reverse Gate	REVERSE GATE	A reverse-playback type ER.

### Delays

#	Title	Type	Description
08	Mono Delay	MONO DELAY	Mono delay with simple operation. Use when you don't need to use complex parameter settings.
09	Stereo Delay	STEREO DELAY	Stereo delay with independent left and right.
10	Mod.delay	MOD.DELAY	Mono delay with modulation.
11	Delay LCR	DELAY LCR	Three-tap delay (L, C, R).
12	Echo	ECHO	Stereo delay with additional parameters for more detailed control. The signal can be fed back from left to right, and right to left.

### Modulation-type Effects

#	Title	Type	Description
13	Chorus	CHORUS	Three-phase stereo chorus.
14	Flange	FLANGE	The well-known flanging effect.
15	Symphonic	SYMPHONIC	A Yamaha proprietary effect that produces a richer and more complex modulation than chorus.
16	Phaser	PHASER	Stereo phaser with 2–16 stages of phase shift.
17	Auto Pan	AUTO PAN	An effect which cyclically moves the sound between left and right.
18	Tremolo	TREMOLO	Tremolo
19	HQ.Pitch	HQ.PITCH	Only one note is pitch-shifted, but a stable effect is produced.
20	Dual Pitch	DUAL PITCH	Stereo pitch shift with left and right pitches set independently.
21	Rotary	ROTARY	Simulation of a rotary speaker.

#	Title	Type	Description
22	Ring Mod.	RING MOD.	An effect that modifies the pitch by applying amplitude modulation to the frequency of the input. On the 01V, even the modulation frequency can be controlled by modulation.
23	Mod.Filter	MOD.FILTER	An effect which uses an LFO to modulate the frequency of the filter.

### Guitar Effects

#	Title	Type	Description
24	Distortion	DISTORTION	Distortion
25	Amp Simulate	AMP SIMULATE	Guitar Amp Simulator

### Dynamic Effects

#	Title	Type	Description
26	Dyna.Filter	DYNA.FILTER	Dynamically controlled filter. Responds to MIDI Note On velocity when SOURCE set to MIDI.
27	Dyna.Flange	DYNA.FLANGE	Dynamically controlled flanger. Responds to MIDI Note On velocity when SOURCE set to MIDI.
28	Dyna.Phaser	DYNA.PHASER	Dynamically controlled phase shifter. Responds to MIDI Note On velocity when SOURCE set to MIDI.

### Combined Effects

#	Title	Type	Description
29	Rev+Chorus	REV+CHORUS	Reverb and chorus in parallel
30	Rev->Chorus	REV->CHORUS	Reverb and chorus in series
31	Rev+Flange	REV+FLANGE	Reverb and flanger in parallel
32	Rev->Flange	REV->FLANGE	Reverb and flanger in series
33	Rev+Sympho.	REV+SYMPHO.	Reverb and symphonic in parallel
34	Rev->Sympho.	REV->SYMPHO.	Reverb and symphonic in series
35	Rev->Pan	REV->PAN	Reverb and auto-pan in parallel
36	Delay+ER.	DELAY+ER.	Delay and early reflections in parallel
37	Delay->ER.	DELAY->ER.	Delay and early reflections in series
38	Delay+Rev	DELAY+REV	Delay and reverb in parallel
39	Delay->Rev	DELAY->REV	Delay and reverb in series
40	Dist->Delay	DIST->DELAY	Distortion and delay in series

### Other Effects

#	Title	Type	Description
41	Multi.Filter	MULTI.FILTER	Three-band parallel filter (24 dB/octave). Easily setup when used with the Internal Parameter function on REMOTE page 1 (see page 194).
42	Freeze	FREEZE	Basic Sampler

## Using the Effects

There are two stages to applying effects: 1) Sending the input channel signal to an effects processor. 2) Returning the processed signal back into the mix. The following three sections explain how to send signals from input channels 1 through 16, 17 through 24, and the effects returns to effects processors. The final section explains how to return the processed signal back into the mix.

### For Input Channels 1–16

1. Press the [HOME] button, and then raise the fader of the channel to which you want to apply an effect.

This step is necessary because effects sends are initially configured as post-fader sends. If the channel fader is not raised, no signal is fed to the effects sends. See “Pre-fader/Post-fader Effects Sends” on page 125 for more information.

2. Press the [EFFECT 1] or [EFFECT 2] button to select an effects processor.

An EFFECT page similar to the one shown below appears, and faders now function as effects send controls.

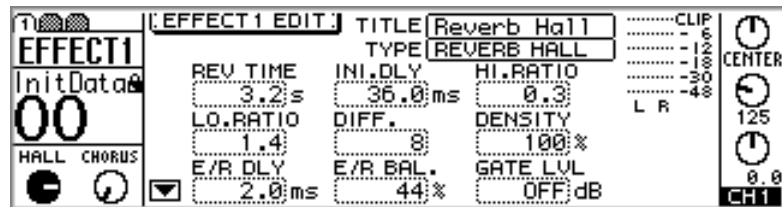

3. Raise the channel's fader (i.e., effects send level control).

This sends the channel signal to the selected effects processor. The effects return meters display the level of the effects return signal.

Since each effects processor has a mono input, the signals of input channels 13 and 14 (likewise 15 and 16) are summed into a mono mix before being fed to an effects processor. When input channels 1 through 12 are paired (“Pairing Input Channels” on page 52), their effects send controls are linked.

### For Input Channels 17–24

1. Use the [OPTION I/O] button to locate OPTION page 2, as shown below.

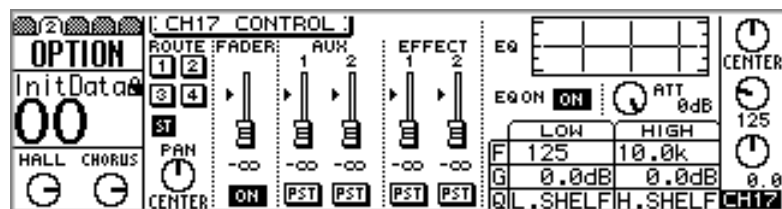

2. Use [SEL] buttons 17 through 24 to select channels.
3. Raise the fader of the channel to which you want to apply an effect.

This step is necessary because effects sends are initially configured as post-fader sends. If the channel fader is not raised, no signal is fed to the effects sends. See “Pre-fader/Post-fader Effects Sends” on page 125 for more information.

4. Use the cursor buttons to select an EFFECT fader, and the PARAMETER wheel or [-1/DEC] and [+1/INC] buttons to set the effects send level.

### For Effects Returns 1 & 2

To prevent signal loops, effects return 1 can be fed only to Effect 2, and effects return 2 can be fed only to Effect 1.

1. Press the [HOME] button, and then turn up the RETURN level control of the effects return to which you want to apply an effect.

This step is necessary because effects sends are initially configured as post-fader sends. If the channel fader is not raised, no signal is fed to the effects sends. See “Pre-fader/Post-fader Effects Sends” on page 125 for more information.

2. Press the [EFFECT 1] or [EFFECT 2] button to select an effects processor.

An EFFECT page similar to the one shown below appears, and effects returns rotary controls now function as effects returns effects send controls.



3. Turn up the effects return RETURN level control (i.e., effects send level control).

This sends the effects return signal to the selected effects processor. The effects return meters display the level of the effects return signal.

### Returning Processed Signals

The final stage to applying effects is to return the processed signal back into the mix.

1. Press the [HOME] button.  
Faders now function as regular channels faders.
2. Turn up the effects return control corresponding to the effect that you are using: Return 1 for Effect 1, Return 2 for Effect 2.

The processed signal is returned into the mix.

3. Set the EQ, pan, and so on for the effects return channel.

Effects programs can be recalled from the effects library. See “Recalling Effects Programs” on page 134 for more information.



## Pre-fader/Post-fader Effects Sends

Effects sends on input channels 1 through 24 and effects returns 1 and 2 can be configured as either pre-fader or post-fader sends. Pre-fader means that signals are sourced before, and are not affected by the regular channel fader. Post-fader means that signals are sourced after, and are affected by the regular channel fader. With a post-fader send, the regular channel fader can be used to control the channel level and the effects send level simultaneously.

### For Input Channels 1–16 & the Effects Returns

1. Use the [EFFECT 1] button to locate the PRE/POST page for Effect 1, or the [EFFECT 2] button to locate the PRE/POST page for Effect 2.

Both pages are shown below.

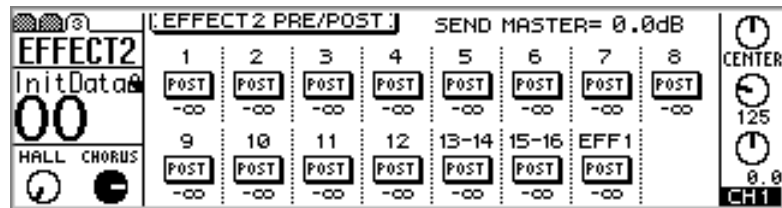
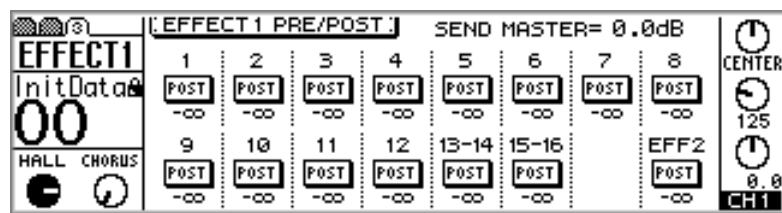

The value below each PRE/POST switch indicates the position of the effects send fader. The position of the corresponding effects send master fader is displayed at the top of the page.

To prevent signal loops, effects return 1 can be fed only to Effect 2, and effects return 2 can be fed only to Effect 1. This is why EFFECT1 page 3 does not have a PRE/POST switch for effect 1, and EFFECT2 page 3 does not have a PRE/POST switch for effect 2.

2. Use the [SEL] buttons or cursor buttons to select the PRE/POST switches, and the [ENTER] button, PARAMETER wheel, or [-1/DEC] and [+1/INC] buttons to set them.

The PRE/POST switches on input channels 13 and 14 (likewise 15 and 16) are permanently linked. When input channels 1 through 12 are paired (“Pairing Input Channels” on page 52), their PRE/POST switches are linked.

### For Input Channels 17–24

1. Use the [OPTION I/O] button to locate OPTION page 2, as shown below.

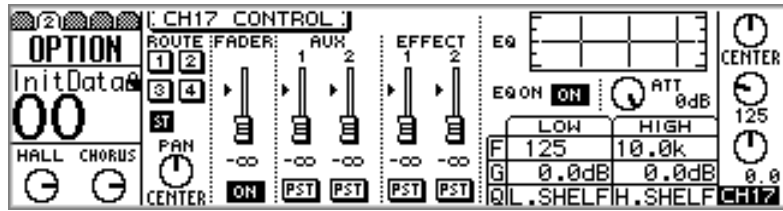

2. Use [SEL] buttons 17 through 24 to select channels.
3. Use the cursor buttons to select the EFFECT PRE/POST switches, and the PARAMETER wheel or [-1/DEC] and [+1/INC] buttons to set them.

## Viewing Effects Send Settings

Settings for the effects sends can be viewed, and certain parameters adjusted on VIEW pages 1 and 2.

1. Use the [EFFECT 1] or [EFFECT 2] button to select an effects send, and then press the MASTER [SEL] button.

EFF1 or EFF2 appears on the display, indicating that an effects send is selected.

2. Use the [VIEW] button to locate VIEW pages 1 and 2, as shown below.

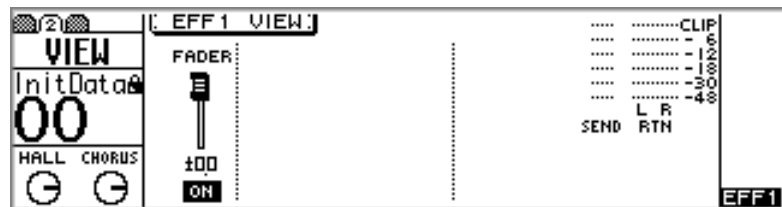
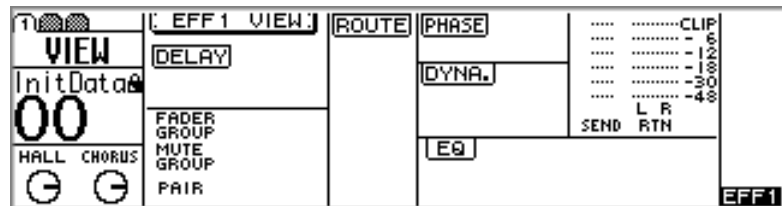

3. Use the cursor buttons to select the parameters, and the PARAMETER wheel, [-1/DEC], [+1/INC], and [ENTER] buttons to set them.

Parameters are explained in the following sections.

## Metering Effects Sends

Effects sends signal levels can be metered on the VIEW pages. See “Viewing Effects Send Settings” on page 127 for more information.

## Setting Effects Send Master Levels

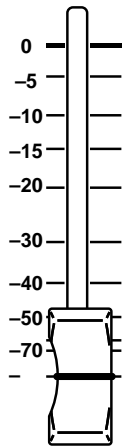

Effects send master levels are controlled using the MASTER fader. The function of this fader depends on the selected Fader mode. See “Faders (plus Return Rotary Controls)” on page 35 for more information.



1. Use the [EFFECT 1] or [EFFECT 2] button to select an effects send.

An EFFECT page similar to the one shown below appears.

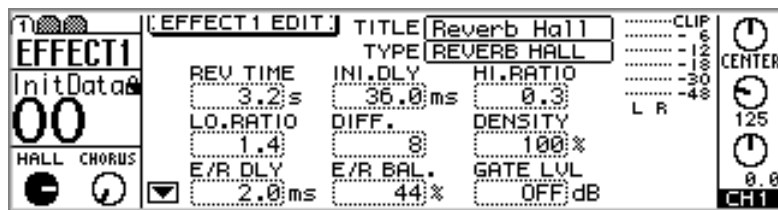

The MASTER fader now functions as effects send master level control for the selected effects send.

2. Use the MASTER fader to set the effects send master level.

The position of the effects send master fader is displayed at the top of the EFFECT PRE/POST page.

The effects send master levels can be viewed and adjusted on the VIEW pages. See “Viewing Effects Send Settings” on page 127 for more information.

## Muting Effects Sends



Effects send masters can be muted using the MASTER [ON] button, which lights up when an effects send is on. The function of this button depends on the selected Fader mode. See “ON Buttons” on page 34 for more information.

1. Use the [EFFECT 1] or [EFFECT 2] button to select an effects send.

An EFFECT page similar to the one shown below appears.

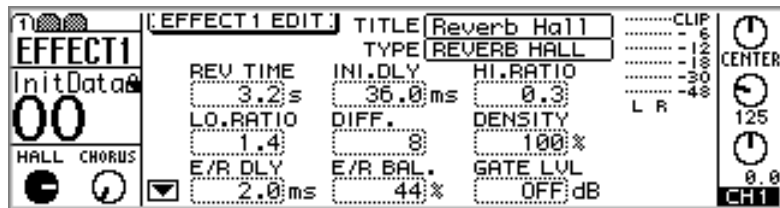

The MASTER [ON] button now functions as effects send master on/off switch for the selected effects send.

2. Use the MASTER [ON] button to turn the effects send on or off.

The effects send master switches can be viewed and set on the VIEW pages. See “Viewing Effects Send Settings” on page 127 for more information.

## Viewing Effects Returns Settings

Settings for the effects returns can be viewed, and certain parameters adjusted on VIEW pages 1 and 2.

1. Use the effects returns [SEL] button to select an effects returns. RTN1 or RTN2 appears on the display, indicating that an effects return is selected.
2. Use the [VIEW] button to locate VIEW pages 1 and 2, as shown below.

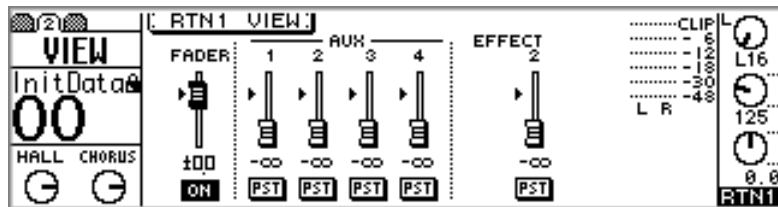
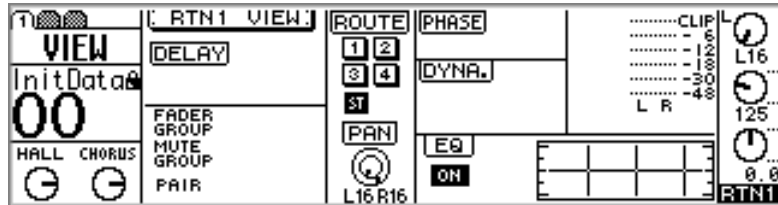

3. Use the cursor buttons to select the parameters, and the PARAMETER wheel, [-1/DEC], [+1/INC], and [ENTER] buttons to set them. Parameters are explained in the following sections.

## Metering Effects Returns

Effects returns signal levels can be metered on the EFFECT and VIEW pages. See “Using the Effects” on page 123 and “Viewing Effects Returns Settings” on page 130.

## Applying EQ to Effects Returns

Effects returns feature four-band parametric EQ. See “EQ” on page 61 for more information. The EQ can be turned on or off, and the EQ curve viewed on the VIEW page. See “Viewing Effects Returns Settings” on page 130 for more information.

## Muting Effects Returns



Effects returns can be turned on and off (i.e., muted) using the effects returns [ON] buttons. When an effects returns is on, its [ON] button lights up.

## Setting Effects Returns Levels



Effects return levels are controlled using the effects return rotary controls.

To adjust the level of an effects return, press the [HOME] button, and then use the rotary controls.

Rotary control operation depends on the selected Fader mode. See “Faders (plus Return Rotary Controls)” on page 35 for more information. The selected fader mode is shown on the display. See “Display” on page 28 for more information.

## Panning Effects Returns

Effects return panpots are used to pan signals between the left and right channels of the stereo out, and the odd and even bus outs. See “Panning Input Channels” on page 47 for more information.

## Routing Effects Returns

Effects returns can be routed to the four buses and stereo out. See “Routing Input Channels” on page 49 for more information.

## Monitoring Effects Returns

Effects returns can be monitored using the monitor out or phones. See “Monitor Setup” on page 78 for more information.

## Effects Returns & Aux Sends

Signals from effects returns 1 and 2 can be sent to aux sends 1 through 4. Effects return sends can be configured as either pre-fader or post-fader sends. When aux sends are paired, aux send panpots become available on each effects return. See “Aux Sends” on page 93 for more information.

## Effects Library

Effects settings are stored as programs in the effects library, which contains 42 preset programs (1–42) and 57 user programs (43–99). User programs are used to store custom effects settings, which can be titled for easy identification. The effects library can also be used to transfer settings from one effects processor to another. For example, the Effect 1 settings could be stored as a library program and then recalled to Effect 2. The unique collection of preset effects programs is designed for specific applications and instruments, and provides a good reference and starting point when using the effects processors. See page 121 for a complete list of the preset effects programs.

The effects library is controlled from the library page shown below. Use the [EFFECT 1] or [EFFECT 2] button to locate it. Although the effects library can be accessed using either button, the effects library is in fact common to both effects processors. When the library page is selected using the [EFFECT 1] button, store and recall operations affect Effect 1. When the library page is selected using the [EFFECT 2] button, store and recall operations affect Effect 2.

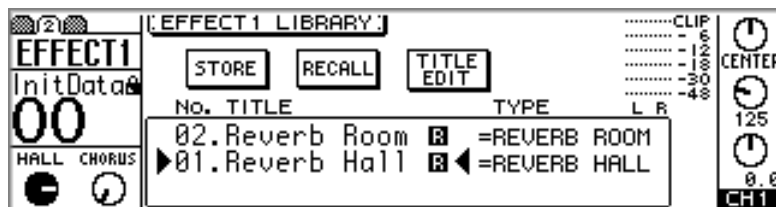

The top half of the library page contains the STORE, RECALL, and TITLE EDIT switches. Below these is the library window, which can be scrolled using the PARAMETER wheel. The “R” icon next to a preset program means read only. The meters indicate effects returns signal levels for the selected effects processor.



## Storing Effects Programs

Custom effects settings can be stored in user programs 43 through 99.

1. Use the [EFFECT 1] or [EFFECT 2] button to locate the library page, as shown below.

To store the effects settings of Effect 1, use the [EFFECT 1] button to locate the library page. To store the effects settings of Effect 2, use the [EFFECT 2] button.

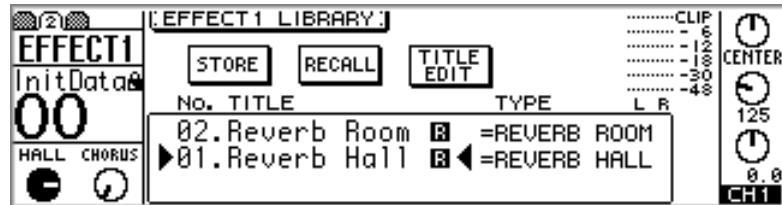

2. Use the PARAMETER wheel or [-1/DEC] and [+1/INC] buttons to select a user program from 43 through 99.

The program list order can be set using the LIBRARY LIST ORDER option in preferences (“Setting 01V Preferences” on page 203).

3. Use the cursor buttons to select the STORE switch, and then press the [ENTER] button.

The Title Edit dialog box appears. If the STORE CONFIRMATION option is turned off in the preferences (“Setting 01V Preferences” on page 203), the Title Edit dialog box does not appear and the effects program is stored.

4. Title the effects program.

See “Title Edit Dialog Box” on page 37 for more information.

5. Select OK, and then press the [ENTER] button.

The effects program is stored.

## Recalling Effects Programs

Effects programs 1 through 99 can be recalled. Programs that use the HQ, PITCH or FREEZE effects can be recalled only to Effect 2.

1. Use the [EFFECT 1] or [EFFECT 2] button to locate the Library page, as shown below.

To recall an effects program to Effect 1, use the [EFFECT 1] button to locate the library page. To recall an effects program to Effect 2, use the [EFFECT 2] button.

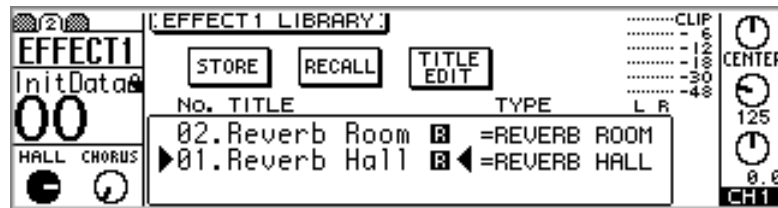

2. Use the PARAMETER wheel or [-1/DEC] and [+1/INC] buttons to select programs.

As each program is selected its type is displayed.

The program list order can be set using the LIBRARY LIST ORDER option in preferences (“Setting 01V Preferences” on page 203).

3. Use the cursor buttons to select the RECALL switch, and then press the [ENTER] button.

The effects program is recalled. If the RECALL CONFIRMATION option is turned on in the preferences (“Setting 01V Preferences” on page 203), a confirmation dialog box appears. In this case, select OK, and then press the [ENTER] button to confirm the recall.

## Editing Effects Program Titles

User program titles can be edited using the Title Edit function.

1. Use the [EFFECT 1] or [EFFECT 2] button to locate the library page, as shown below.

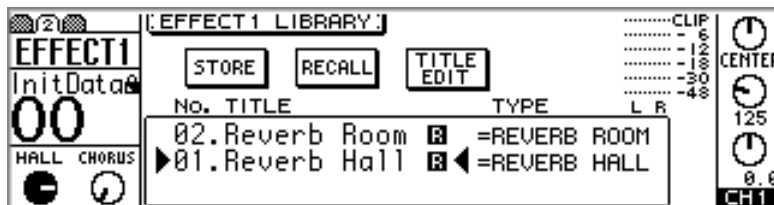

2. Use the PARAMETER wheel or [-1/DEC] and [+1/INC] buttons to select a user program from 43 through 99.
3. Use the cursor buttons to select the TITLE EDIT switch, and then press the [ENTER] button.  
The Title Edit dialog box appears.
4. Edit the program title.  
See “Title Edit Dialog Box” on page 37 for more information.
5. Select OK, and then press the [ENTER] button.  
The program is stored with its new title.

## Editing Effects

Effects programs can be edited, and then stored as user programs.

1. Press the [EFFECT 1] or [EFFECT 2] button to locate EFFECT1 page 1 or EFFECT2 page 1, depending on which effect you want to edit.

EFFECT1 page 1 is shown below.



2. Use the cursor buttons to select the effects parameters, and the PARAMETER wheel or [-1/DEC] and [+1/INC] buttons to set them.

Up and down arrow icons, like the down icon on this page, indicate that more parameters are available and can be selected using the up and down cursor buttons.

Effects parameters, including variable range and description, are listed on page 138.

To store the edited program, see “Storing Effects Programs” on page 133.

## Setting Delay, Freq, Note & Tempo Parameters

Delay parameters can be set manually by entering the delay time in milliseconds, or automatically by entering the NOTE and TEMPO parameters. For example, with the TEMPO set to 120 beats per minute and NOTE set to eighth note, the delay is automatically set to 250 milliseconds, as shown below. With the TEMPO still at 120 beats per minute, changing the DELAY to 500.0 milliseconds would automatically set the NOTE parameter to quarter note. Similarly, changing the NOTE parameter to sixteenth note would automatically set the DELAY parameter to 125.5 milliseconds. If the TEMPO parameter is changed, the DELAY parameter is automatically recalculated.

The TEMPO can be set from 25 to 300 beats per minute, although the range may be reduced if the DELAY parameter calculation exceeds the maximum delay time.

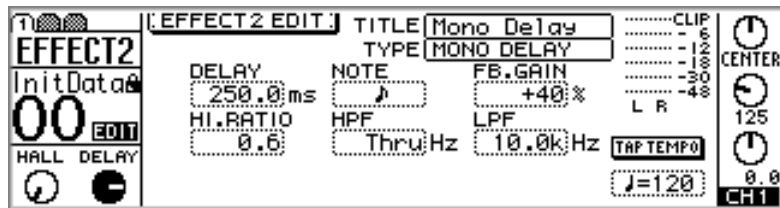

The FREQ. parameter for modulation-type effects can also be set either manually or automatically. For example, with the TEMPO set to 120 beats per minute and NOTE set to quarter note, the FREQ. is automatically set to 2.00 hertz, as shown below. With the TEMPO still at 120 beats per minute, changing the FREQ. to 4.00 hertz would automatically set the NOTE parameter to eighth note. Similarly, changing the NOTE parameter to sixteenth note would automatically set the FREQ. parameter to 8.00 hertz. If the TEMPO parameter is changed, the FREQ. parameter is automatically recalculated.

The TEMPO can be set from 25 to 300 beats per minute, although the range may be reduced if the FREQ. parameter calculation exceeds the maximum frequency.

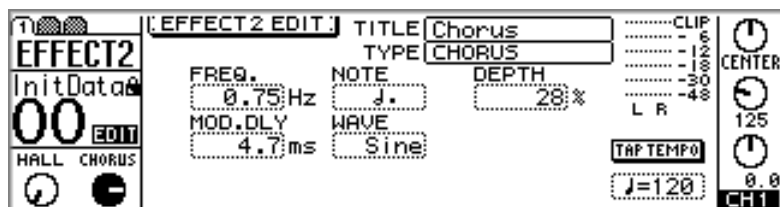

The TEMPO parameter can be entered manually or by using the Tap Tempo function. To use Tap Tempo, select the TAP TEMPO switch, and then press the [ENTER] button on each beat. The TEMPO is calculated automatically based on the time between each button press.

Only the DELAY and FREQ. parameters can be controlled by using MIDI Control Change and System Exclusive Parameter Change messages.

## Effects Parameters

### REVERB HALL, REVERB ROOM, REVERB STAGE, REVERB PLATE

Hall, room, stage, and plate simulations, all with gates.

Parameter	Range	Description
REV TIME	0.3–99.9 s	Reverb time
INI.DLY	0.0–500.0 ms	Initial delay before reverb begins
HI.RATIO	0.1–1.0	High-frequency reverb time ratio
LO.RATIO	0.1–2.4	Low-frequency reverb time ratio
DIFF.	0–10	Reverb diffusion (left–right reverb spread)
DENSITY	0–100%	Reverb density
E/R DLY	0.0–100.0 ms	Delay between early reflections and reverb
E/R BAL.	0–100%	Balance of early reflections and reverb (0% = ER, 100% = reverb)
GATE LVL	OFF, –60 to 0 dB	Level at which gate kicks in
ATTACK	0–120 ms	Gate opening speed
HOLD	*1	Gate open time
DECAY	*2	Gate closing speed
HPF	Thru, 21 Hz–8.0 kHz	High-pass filter cutoff frequency
LPF	50 Hz–16.0 kHz, Thru	Low-pass filter cutoff frequency

1. 0.02 ms–2.13 s ( $f_s=44.1$  kHz), 0.02 ms–1.96 s ( $f_s=48$  kHz)

2. 6.0 ms–46.0 s ( $f_s=44.1$  kHz), 5.0 ms–42.3 s ( $f_s=48$  kHz)

### EARLY REF.

Early reflections.

Parameter	Range	Description
TYPE	S-Hall, L-Hall, Random, Revers, Plate, Spring	Type of early reflection simulation
ROOMSIZE	0.1–20.0	Reflection spacing
LIVENESS	0–10	Early reflections decay characteristics (0 = dead, 10 = live)
INI.DLY	0.0–500.0 ms	Initial delay before reverb begins
DIFF.	0–10	Reverb diffusion (left–right reverb spread)
DENSITY	0–100%	Reverb density
ER NUM.	1–19	Number of early reflections
FB GAIN	–99 to +99%	Feedback gain
HI.RATIO	0.1–1.0	High-frequency feedback ratio
HPF	Thru, 21 Hz–8.0 kHz	High-pass filter cutoff frequency
LPF	50 Hz–16.0 kHz, Thru	Low-pass filter cutoff frequency

## GATE REVERB, REVERSE GATE

Early reflections with gate, and early reflections with reverse gate.

Parameter	Range	Description
TYPE	Type-A, Type-B	Type of early reflection simulation
ROOMSIZE	0.1–20.0	Reflection spacing
LIVENESS	0–10	Early reflections decay characteristics (0 = dead, 10 = live)
INI.DLY	0.0–500.0 ms	Initial delay before reverb begins
DIFF.	0–10	Reverb diffusion (left–right reverb spread)
DENSITY	0–100%	Reverb density
HI.RATIO	0.1–1.0	High-frequency feedback ratio
ER NUM.	1–19	Number of early reflections
FB GAIN	–99 to +99%	Feedback gain
HPF	Thru, 21 Hz–8.0 kHz	High-pass filter cutoff frequency
LPF	50 Hz–16.0 kHz, Thru	Low-pass filter cutoff frequency

## MONO DELAY

Basic repeat delay.

Parameter	Range	Description
DELAY	0.0–2730.0 ms	Delay time
NOTE	*1	Used in conjunction with TEMPO to determine DELAY
FB.GAIN	–99 to +99%	Feedback gain (plus values for normal-phase feedback, minus values for reverse-phase feedback)
HI.RATIO	0.1–1.0	High-frequency feedback ratio
HPF	Thru, 21 Hz–8.0 kHz	High-pass filter cutoff frequency
LPF	50 Hz–16.0 kHz, Thru	Low-pass filter cutoff frequency
TEMPO*2	25–300 bps	Used in conjunction with NOTE to determine DELAY

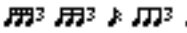
1.  (Maximum value depends on the tempo setting)
2. For more information about the DELAY, NOTE, and TEMPO parameters, see “Setting Delay, Freq, Note & Tempo Parameters” on page 137.

## STEREO DELAY

Basic stereo delay.

Parameter	Range	Description
DELAY L	0.0–1350.0 ms	Left channel delay time
NOTE L	*1	Used in conjunction with TEMPO to determine left channel DELAY
FB.G L	–99 to +99%	Left channel feedback (plus values for normal-phase feedback, minus values for reverse-phase feedback)
DELAY R	0.0–1350.0 ms	Right channel delay time
NOTE R	*1	Used in conjunction with TEMPO to determine right channel DELAY
FB.G R	–99 to +99%	Right channel feedback (plus values for normal-phase feedback, minus values for reverse-phase feedback)
HI.RATIO	0.1–1.0	High-frequency feedback ratio
HPF	Thru, 21 Hz–8.0 kHz	High-pass filter cutoff frequency
LPF	50 Hz–16.0 kHz, Thru	Low-pass filter cutoff frequency
TEMPO*2	25–300 bps	Used in conjunction with NOTE L and NOTE R to determine DELAY

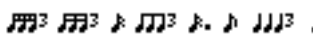
1.  (Maximum value depends on the tempo setting)
2. For more information about the DELAY, NOTE, and TEMPO parameters, see “Setting Delay, Freq, Note & Tempo Parameters” on page 137.

## MOD.DELAY

Basic repeat delay with modulation.

Parameter	Range	Description
DELAY	0.0–2725.0 ms	Delay time
DLY NOTE	*1	Used in conjunction with TEMPO to determine DELAY
FB.GAIN	–99 to +99%	Feedback gain (plus values for normal-phase feedback, minus values for reverse-phase feedback)
FREQ.	0.05–40.00 Hz	Modulation speed
MOD NOTE	*2	Used in conjunction with TEMPO to determine FREQ
DEPTH	0–100%	Modulation depth
HI.RATIO	0.1–1.0	High-frequency feedback ratio
HPF	Thru, 21 Hz–8.0 kHz	High-pass filter cutoff frequency
LPF	50 Hz–16.0 kHz, Thru	Low-pass filter cutoff frequency
TEMPO*3	25–300 bps	Used in conjunction with DLY NOTE and MOD NOTE to determine DELAY and FREQ.

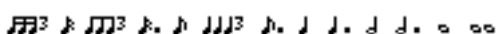
1.  (Maximum value depends on the tempo setting)
2. 
3. For more information about the DELAY, NOTE, and TEMPO parameters, see “Setting Delay, Freq, Note & Tempo Parameters” on page 137.



## DELAY LCR

Three-tap delay (left, center, right).

Parameter	Range	Description
DELAY L	0.0–2730.0 ms	Left channel delay time
NOTE L	*1	Used in conjunction with TEMPO to determine DELAY L
LEVEL L	–100 to +100%	Left channel delay level
DELAY C	0.0–2730.0 ms	Center channel delay time
NOTE C	*1	Used in conjunction with TEMPO to determine DELAY C
LEVEL C	–100 to +100%	Center channel delay level
DELAY R	0.0–2730.0 ms	Right channel delay time
NOTE R	*1	Used in conjunction with TEMPO to determine DELAY R
LEVEL R	–100 to +100%	Right channel delay level
FB.DLY	0.0–2730.0 ms	Feedback delay time
NOTE FB	*1	Used in conjunction with TEMPO to determine FB.DLY
FB.GAIN	–99 to +99%	Feedback gain (plus values for normal-phase feedback, minus values for reverse-phase feedback)
HI.RATIO	0.1–1.0	High-frequency feedback ratio
HPF	Thru, 21 Hz–8.0 kHz	High-pass filter cutoff frequency
LPF	50 Hz–16.0 kHz, Thru	Low-pass filter cutoff frequency
TEMPO*2	25–300 bps	Used in conjunction with NOTE parameters to determine DELAY L, DELAY C, DELAY R, and FB.DLY

1.  (Maximum value depends on the tempo setting)
2. For more information about the DELAY, NOTE, and TEMPO parameters, see “Setting Delay, Freq, Note & Tempo Parameters” on page 137.

## ECHO

Stereo delay with crossed feedback loop.

Parameter	Range	Description
DELAY L	0.0–1350.0 ms	Left channel delay time
NOTE L	*1	Used in conjunction with TEMPO to determine DELAY L
FB.G L	–99 to +99%	Left channel feedback gain (plus values for normal-phase feedback, minus values for reverse-phase feedback)
DELAY R	0.0–1350.0 ms	Right channel delay time
NOTE R	*1	Used in conjunction with TEMPO to determine DELAY R
FB.G R	–99 to +99%	Right channel feedback gain (plus values for normal-phase feedback, minus values for reverse-phase feedback)
FB.D L	0.0–1350.0 ms	Left channel feedback delay time
NOTE FBL	*1	Used in conjunction with TEMPO to determine FB.D L
L->R FB.G	–99 to +99%	Left to right channel feedback gain (plus values for normal-phase feedback, minus values for reverse-phase feedback)
FB.D R	0.0–1350.0 ms	Right channel feedback delay time
NOTE FBR	*1	Used in conjunction with TEMPO to determine FB.D R
R->L FB.G	–99 to +99%	Right to left channel feedback gain (plus values for normal-phase feedback, minus values for reverse-phase feedback)
HI.RATIO	0.1–1.0	High-frequency feedback ratio
HPF	Thru, 21 Hz–8.0 kHz	High-pass filter cutoff frequency
LPF	50 Hz–16.0 kHz, Thru	Low-pass filter cutoff frequency
TEMPO*2	25–300 bps	Used in conjunction with NOTE parameters to determine DELAY L, DELAY R, FB.D L, and FB.D R

1.  (Maximum value depends on the tempo setting)
2. For more information about the DELAY, NOTE, and TEMPO parameters, see “Setting Delay, Freq, Note & Tempo Parameters” on page 137.

## CHORUS

Chorus effect.

Parameter	Range	Description
FREQ.	0.05–40.00 Hz	Modulation speed
NOTE	*1	Used in conjunction with TEMPO to determine FREQ.
DEPTH	0–100%	Modulation depth
MOD.DLY	0.0–500.0 ms	Modulation delay time
WAVE	Sine, Tri	Modulation waveform
TEMPO*2	25–300 bps	Used in conjunction with NOTE to determine FREQ.

1. 
2. For more information about the FREQ., NOTE, and TEMPO parameters, see “Setting Delay, Freq, Note & Tempo Parameters” on page 137.

## FLANGE

Flange effect.

Parameter	Range	Description
FREQ.	0.05–40.00 Hz	Modulation speed
NOTE	*1	Used in conjunction with TEMPO to determine FREQ.
DEPTH	0–100%	Modulation depth
MOD.DLY	0.0–500.0 ms	Modulation delay time
FB.GAIN	–99 to +99%	Feedback gain (plus values for normal-phase feedback, minus values for reverse-phase feedback)
WAVE	Sine, Tri	Modulation waveform
TEMPO*2	25–300 bps	Used in conjunction with NOTE to determine FREQ.

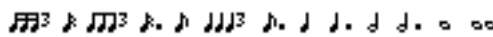
- 
- For more information about the FREQ., NOTE, and TEMPO parameters, see “Setting Delay, Freq, Note & Tempo Parameters” on page 137.

## SYMPHONIC

Symphonic effect.

Parameter	Range	Description
FREQ.	0.05–40.00 Hz	Modulation speed
NOTE	*1	Used in conjunction with TEMPO to determine FREQ.
DEPTH	0–100%	Modulation depth
MOD.DLY	0.0–500.0 ms	Modulation delay time
WAVE	Sine, Tri	Modulation waveform
TEMPO*2	25–300 bps	Used in conjunction with NOTE to determine FREQ.

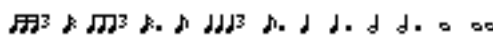
- 
- For more information about the FREQ., NOTE, and TEMPO parameters, see “Setting Delay, Freq, Note & Tempo Parameters” on page 137.

## PHASER

16-stage phaser.

Parameter	Range	Description
FREQ.	0.05–40.00 Hz	Modulation speed
NOTE	*1	Used in conjunction with TEMPO to determine FREQ.
DEPTH	0–100%	Modulation depth
FB.GAIN	–99 to +99%	Feedback gain (plus values for normal-phase feedback, minus values for reverse-phase feedback)
OFFSET	0–100	Lowest phase-shifted frequency offset
STAGE	2, 4, 8, 10, 12, 14, 16	Number of phase shift stages
TEMPO*2	25–300 bps	Used in conjunction with NOTE to determine FREQ.

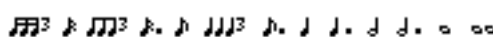
- 
- For more information about the FREQ., NOTE, and TEMPO parameters, see “Setting Delay, Freq, Note & Tempo Parameters” on page 137.

## AUTOPAN

Auto-panner.

Parameter	Range	Description
FREQ.	0.05–40.00 Hz	Modulation speed
NOTE	*1	Used in conjunction with TEMPO to determine FREQ.
DEPTH	0–100%	Modulation depth
DIR.	*2	Panning direction
WAVE	Sine, Tri, Square	Modulation waveform
TEMPO* <sup>3</sup>	25–300 bps	Used in conjunction with NOTE to determine FREQ.

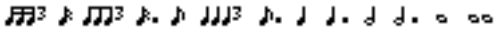
1. 
2. L<->R, L->R, L<-R, Turn L, Turn R
3. For more information about the FREQ., NOTE, and TEMPO parameters, see “Setting Delay, Freq, Note & Tempo Parameters” on page 137.

## TREMOLO

Tremolo effect.

Parameter	Range	Description
FREQ.	0.05–40.00 Hz	Modulation speed
NOTE	*1	Used in conjunction with TEMPO to determine FREQ.
DEPTH	0–100%	Modulation depth
WAVE	Sine, Tri, Square	Modulation waveform
TEMPO* <sup>2</sup>	25–300 bps	Used in conjunction with NOTE to determine FREQ.

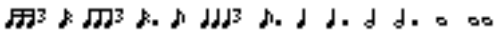
1. 
2. For more information about the FREQ., NOTE, and TEMPO parameters, see “Setting Delay, Freq, Note & Tempo Parameters” on page 137.

## HQ.PITCH (Effect 2 only)

High-quality pitch shifter.

Parameter	Range	Description
PITCH	-12 to +12 semitones	Pitch shift
FINE	-50 to +50 cents	Pitch shift fine
MODE	1–10	Pitch shift precision
DELAY	0.0–1000.0 ms	Delay time
NOTE	*1	Used in conjunction with TEMPO to determine DELAY
FB.GAIN	-99 to +99%	Feedback gain (plus values for normal-phase feedback, minus values for reverse-phase feedback)
TEMPO* <sup>2</sup>	25–300 bps	Used in conjunction with NOTE to determine DELAY

1.  (Maximum value depends on the tempo setting)
2. For more information about the DELAY, NOTE, and TEMPO parameters, see “Setting Delay, Freq, Note & Tempo Parameters” on page 137.

## DUAL PITCH

Twin-voice pitch shifter.

Parameter	Range	Description
PITCH L	-24 to +24 semitones	Left channel pitch shift
FINE L	-50 to +50 cents	Left channel pitch shift fine
LEVEL L	-100 to +100%	Left channel level (plus values for normal phase, minus values for reverse phase)
PITCH R	-24 to +24 semitones	Right channel pitch shift
FINE R	-50 to +50 cents	Right channel pitch shift fine
LEVEL R	-100 to +100%	Right channel level (plus values for normal phase, minus values for reverse phase)
DELAY L	0.0–1000.0 ms	Left channel delay time
NOTE L	*1	Used in conjunction with TEMPO to determine DELAY L
FB.G L	-99 to +99%	Left channel feedback gain (plus values for normal-phase feedback, minus values for reverse-phase feedback)
DELAY R	0.0–1000.0 ms	Right channel delay time
NOTE R	*1	Used in conjunction with TEMPO to determine DELAY R
FB.G R	-99 to +99%	Right channel feedback gain (plus values for normal-phase feedback, minus values for reverse-phase feedback)
MODE	1–10	Pitch shift precision
TEMPO* <sup>2</sup>	25–300 bps	Used in conjunction with NOTE parameters to determine DELAY L and DELAY R

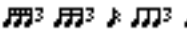
1.  (Maximum value depends on the tempo setting)
2. For more information about the DELAY, NOTE, and TEMPO parameters, see “Setting Delay, Freq, Note & Tempo Parameters” on page 137.

## ROTARY

Rotary speaker simulator.

Parameter	Range	Description
ROTATE	STOP, START	Rotation stop, start
SPEED	SLOW, FAST	Rotation speed (see SLOW and FAST parameters)
DRIVE	0–100	Overdrive level
ACCEL	0–10	Acceleration at speed changes
LOW	0–100	Low-frequency filter
HIGH	0–100	High-frequency filter
SLOW	0.05–10.00 Hz	SLOW rotation speed
FAST	0.05–10.00 Hz	FAST rotation speed

## RING MOD.

Ring modulator.

Parameter	Range	Description
SOURCE	OSC, SELF	Modulation source: oscillator or input signal
OSC FREQ	0.0–3000.0 Hz	Oscillator frequency
FM FREQ	0.05–40.00 Hz	Oscillator frequency modulation speed
NOTE FM	*1	Used in conjunction with TEMPO to determine FM FREQ
FM DEPTH	0–100%	Oscillator frequency modulation depth
TEMPO*2	25–300 bps	Used in conjunction with NOTE FM to determine FM FREQ

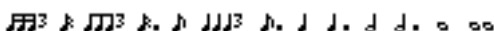
1. 
2. For more information about the FM FREQ., NOTE FM, and TEMPO parameters, see “Setting Delay, Freq, Note & Tempo Parameters” on page 137.

## MOD.FILTER

LFO modulation-type filter.

Parameter	Range	Description
FREQ.	0.05–40.00 Hz	Modulation speed
NOTE	*1	Used in conjunction with TEMPO to determine FREQ
DEPTH	0–100%	Modulation depth
TYPE	LPF, HPF, BPF	Filter type: low pass, high pass, band pass
OFFSET	0–100	Filter frequency offset
RESO.	0–20	Filter resonance
PHASE	0.00–354.38°	Left-channel modulation and right-channel modulation phase difference
LEVEL	0–100	Output level
TEMPO*2	25–300 bps	Used in conjunction with NOTE to determine FREQ.

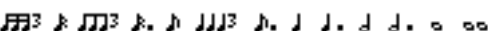
1. 
2. For more information about the FREQ., NOTE, and TEMPO parameters, see “Setting Delay, Freq, Note & Tempo Parameters” on page 137.

## DISTORTION

Distortion effect.

Parameter	Range	Description
DST TYPE	DST1, DST2, OVD1, OVD2, CRUNCH	Distortion type (DST = distortion, OVD = overdrive)
DRIVE	0–100	Distortion drive
MASTER	0–100	Master volume
TONE	–10 to +10	Tone
N.GATE	0–20	Noise reduction

## AMP SIMULATE

Guitar Amp Simulator.

Parameter	Range	Description
AMP TYPE	*1	Guitar amp simulation type
DST TYPE	DST1, DST2, OVD1, OVD2, CRUNCH	Distortion type (DST = distortion, OVD = overdrive)
N.GATE	0–20	Noise reduction
DRIVE	0–100	Distortion drive
MASTER	0–100	Master volume
CAB DEP	0–100%	Speaker cabinet simulation depth
BASS	0–100	Bass tone control
MIDDLE	0–100	Middle tone control
TREBLE	0–100	High tone control
EQ F	99–8.0 kHz	Parametric equalizer frequency
EQ G	–12 to +12 dB	Parametric equalizer gain
EQ Q	10.0–0.10	Parametric equalizer bandwidth

1. STK-M1, STK-M2, THRASH, MIDBST, CMB-PG, CMB-VR, CMB-DX, CMB-TW, MINI, FLAT

## DYNA.FILTER

Dynamically controlled filter.

Parameter	Range	Description
SOURCE	INPUT, MIDI	Control source: input signal or MIDI note on velocity
SENSE	0–100	Sensitivity
TYPE	LPF, HPF, BPF	Filter type
OFFSET	0–100	Filter frequency offset
RESO.	0–20	Filter resonance
LEVEL	0–100	Output Level
DIR.	UP, DOWN	Upward or downward frequency change
DECAY	*1	Filter frequency change decay speed

1. 6.0 ms–46.0 s (fs=44.1 kHz), 5.0 ms–42.3 s (fs=48 kHz)

## DYNA.FLANGE

Dynamically controlled flanger.

Parameter	Range	Description
SOURCE	INPUT, MIDI	Control source: input signal or MIDI note on velocity
SENSE	0–100	Sensitivity
FB GAIN	–99 to +99%	Feedback gain (plus values for normal-phase feedback, minus values for reverse-phase feedback)
OFFSET	0–100	Delay time offset
DIR.	UP, DOWN	Upward or downward frequency change
DECAY	*1	Decay speed

1. 6.0 ms–46.0 s (fs=44.1 kHz), 5.0 ms–42.3 s (fs=48 kHz)

## DYNA.PHASER

Dynamically controlled phaser.

Parameter	Range	Description
SOURCE	INPUT, MIDI	Control source: input signal or MIDI note on velocity
SENSE	0–100	Sensitivity
FB GAIN	–99 to +99%	Feedback gain (plus values for normal-phase feedback, minus values for reverse-phase feedback)
OFFSET	0–100	Lowest phase-shifted frequency offset
DIR.	UP, DOWN	Upward or downward frequency change
STAGE	2, 4, 8, 10, 12, 14, 16	Number of phase shift stages
DECAY	*1	Decay speed

1. 6.0 ms–46.0 s (fs=44.1 kHz), 5.0 ms–42.3 s (fs=48kHz)

## REV+CHORUS

Reverb and chorus effects in parallel.

Parameter	Range	Description
REV TIME	0.3–99.9 s	Reverb time
INI.DLY	0.0–500.0 ms	Initial delay before reverb begins
HI.RATIO	0.1–1.0	High-frequency reverb time ratio
DENSITY	0–100%	Reverb density
FREQ.	0.05–40.00 Hz	Modulation speed
NOTE	*1	Used in conjunction with TEMPO to determine FREQ.
DEPTH	0–100%	Modulation depth
MOD.DLY	0.0–500.0 ms	Modulation delay time
WAVE	Sine, Tri	Modulation waveform
REV/CHO	0–100%	Reverb and chorus balance (0% = chorus, 100% = reverb)
HPF	Thru, 21 Hz–8.0 kHz	High-pass filter cutoff frequency
LPF	50 Hz–16.0 kHz, Thru	Low-pass filter cutoff frequency
TEMPO*2	25–300 bps	Used in conjunction with NOTE to determine FREQ.

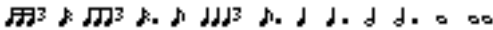
1. 
2. For more information about the FREQ., NOTE, and TEMPO parameters, see “Setting Delay, Freq, Note & Tempo Parameters” on page 137.



## REV->CHORUS

Reverb and chorus effects in series.

Parameter	Range	Description
REV TIME	0.3–99.9 s	Reverb time
INI.DLY	0.0–500.0 ms	Initial delay before reverb begins
HI.RATIO	0.1–1.0	High-frequency reverb time ratio
DENSITY	0–100%	Reverb density
FREQ.	0.05–40.00 Hz	Modulation speed
NOTE	*1	Used in conjunction with TEMPO to determine FREQ.
DEPTH	0–100%	Modulation depth
MOD.DLY	0.0–500.0 ms	Modulation delay time
WAVE	Sine, Tri	Modulation waveform
REV BAL.	0–100%	Reverb and chorused reverb balance (0% = chorused reverb, 100% = reverb)
HPF	Thru, 21 Hz–8.0 kHz	High-pass filter cutoff frequency
LPF	50 Hz–16.0 kHz, Thru	Low-pass filter cutoff frequency
TEMPO*2	25–300 bps	Used in conjunction with NOTE to determine FREQ.

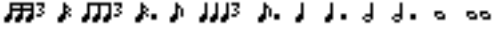
- 
- For more information about the FREQ., NOTE, and TEMPO parameters, see “Setting Delay, Freq, Note & Tempo Parameters” on page 137.

## REV+FLANGE

Reverb and flanger effects in parallel.

Parameter	Range	Description
REV TIME	0.3–99.9 s	Reverb time
INI.DLY	0.0–500.0 ms	Initial delay before reverb begins
HI.RATIO	0.1–1.0	High-frequency reverb time ratio
DENSITY	0–100%	Reverb density
FREQ.	0.05–40.00 Hz	Modulation speed
NOTE	*1	Used in conjunction with TEMPO to determine FREQ.
DEPTH	0–100%	Modulation depth
MOD.DLY	0.0–500.0 ms	Modulation delay time
FB.GAIN	–99 to +99%	Feedback gain (plus values for normal-phase feedback, minus values for reverse-phase feedback)
WAVE	Sine, Tri	Modulation waveform
REV/FLG	0–100%	Reverb and flange balance (0% = flange, 100% = reverb)
HPF	Thru, 21 Hz–8.0 kHz	High-pass filter cutoff frequency
LPF	50 Hz–16.0 kHz, Thru	Low-pass filter cutoff frequency
TEMPO*2	25–300 bps	Used in conjunction with NOTE to determine FREQ.

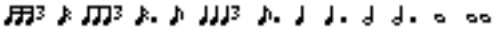
- 
- For more information about the FREQ., NOTE, and TEMPO parameters, see “Setting Delay, Freq, Note & Tempo Parameters” on page 137.

**REV->FLANGE**

Reverb and flanger effects in series.

Parameter	Range	Description
REV TIME	0.3–99.9 s	Reverb time
INI.DLY	0.0–500.0 ms	Initial delay before reverb begins
HI.RATIO	0.1–1.0	High-frequency reverb time ratio
DENSITY	0–100%	Reverb density
FREQ.	0.05–40.00 Hz	Modulation speed
NOTE	*1	Used in conjunction with TEMPO to determine FREQ.
DEPTH	0–100%	Modulation depth
MOD.DLY	0.0–500.0 ms	Modulation delay time
FB.GAIN	–99 to +99%	Feedback gain (plus values for normal-phase feedback, minus values for reverse-phase feedback)
WAVE	Sine, Tri	Modulation waveform
REV BAL.	0–100%	Reverb and flanged reverb balance (0% = flanged reverb, 100% = reverb)
HPF	Thru, 21 Hz–8.0 kHz	High-pass filter cutoff frequency
LPF	50 Hz–16.0 kHz, Thru	Low-pass filter cutoff frequency
TEMPO* <sup>2</sup>	25–300 bps	Used in conjunction with NOTE to determine FREQ.

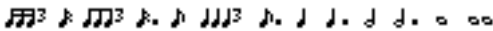
- 
- For more information about the FREQ., NOTE, and TEMPO parameters, see “Setting Delay, Freq, Note & Tempo Parameters” on page 137.

**REV+SYMPHO.**

Reverb and symphonic effects in parallel.

Parameter	Range	Description
REV TIME	0.3–99.9 s	Reverb time
INI.DLY	0.0–500.0 ms	Initial delay before reverb begins
HI.RATIO	0.1–1.0	High-frequency reverb time ratio
DENSITY	0–100%	Reverb density
FREQ.	0.05–40.00 Hz	Modulation speed
NOTE	*1	Used in conjunction with TEMPO to determine FREQ.
DEPTH	0–100%	Modulation depth
MOD.DLY	0.0–500.0 ms	Modulation delay time
WAVE	Sine, Tri	Modulation waveform
REV/SYM	0–100%	Reverb and symphonic balance (0% = symphonic, 100% = reverb)
HPF	Thru, 21 Hz–8.0 kHz	High-pass filter cutoff frequency
LPF	50 Hz–16.0 kHz, Thru	Low-pass filter cutoff frequency
TEMPO* <sup>2</sup>	25–300 bps	Used in conjunction with NOTE to determine FREQ.

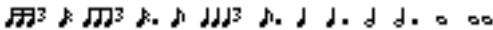
- 
- For more information about the FREQ., NOTE, and TEMPO parameters, see “Setting Delay, Freq, Note & Tempo Parameters” on page 137.

**REV->SYMPHO.**

Reverb and symphonic effects in series.

Parameter	Range	Description
REV TIME	0.3–99.9 s	Reverb time
INI.DLY	0.0–500.0 ms	Initial delay before reverb begins
HI.RATIO	0.1–1.0	High-frequency reverb time ratio
DENSITY	0–100%	Reverb density
FREQ.	0.05–40.00 Hz	Modulation speed
NOTE	*1	Used in conjunction with TEMPO to determine FREQ.
DEPTH	0–100%	Modulation depth
MOD.DLY	0.0–500.0 ms	Modulation delay time
WAVE	Sine, Tri	Modulation waveform
REV BAL.	0–100%	Reverb and symphonic reverb balance (0% = symphonic reverb, 100% = reverb)
HPF	Thru, 21 Hz–8.0 kHz	High-pass filter cutoff frequency
LPF	50 Hz–16.0 kHz, Thru	Low-pass filter cutoff frequency
TEMPO*2	25–300 bps	Used in conjunction with NOTE to determine FREQ.

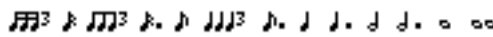
- 
- For more information about the FREQ., NOTE, and TEMPO parameters, see “Setting Delay, Freq, Note & Tempo Parameters” on page 137.

**REV->PAN**

Reverb and auto-pan effects in parallel.

Parameter	Range	Description
REV TIME	0.3–99.9 s	Reverb time
INI.DLY	0.0–500.0 ms	Initial delay before reverb begins
HI.RATIO	0.1–1.0	High-frequency reverb time ratio
DENSITY	0–100%	Reverb density
FREQ.	0.05–40.00 Hz	Modulation speed
NOTE	*1	Used in conjunction with TEMPO to determine FREQ.
DEPTH	0–100%	Modulation depth
DIR.	*2	Panning direction
WAVE	Sine, Tri, Square	Modulation waveform
REV BAL.	0–100%	Reverb and panned reverb balance (0% = panned reverb, 100% = reverb)
HPF	Thru, 21 Hz–8.0 kHz	High-pass filter cutoff frequency
LPF	50 Hz–16.0 kHz, Thru Hz	Low-pass filter cutoff frequency
TEMPO*3	25–300 bps	Used in conjunction with NOTE to determine FREQ.

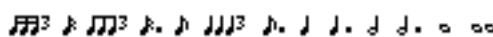
- 
- L<->R, L->R, L<-R, Turn L, Turn R
- For more information about the FREQ., NOTE, and TEMPO parameters, see “Setting Delay, Freq, Note & Tempo Parameters” on page 137.

**DELAY+ER.**

Delay and early reflections effects in parallel.

Parameter	Range	Description
DELAY L	0.0–1000.0 ms	Left channel delay time
NOTE L	*1	Used in conjunction with TEMPO to determine left channel DELAY L
FB.GAIN	–99 to +99%	Feedback gain (plus values for normal-phase feedback, minus values for reverse-phase feedback)
DELAY R	0.0–1000.0 ms	Right channel delay time
NOTE R	*1	Used in conjunction with TEMPO to determine right channel DELAY R
HI.RATIO	0.1–1.0	High-frequency feedback ratio
FB.DLY	0.0–1000.0 ms	Feedback delay time
NOTE FB	*1	Used in conjunction with TEMPO to determine FB.DLY
DLY/ER	0–100%	Delay and early reflections balance (0% = early reflections, 100% = delay)
TYPE	S-Hall, L-Hall, Random, Revers, Plate, Spring	Type of early reflection simulation
ROOMSIZE	0.1–20.0	Reflection spacing
LIVENESS	0–10	Early reflections decay characteristics (0 = dead, 10 = live)
INI.DLY	0.0–500.0 ms	Initial delay before reverb begins
DENSITY	0–100%	Reverb density
ER NUM.	1–19	Number of early reflections
TEMPO*2	25–300 bps	Used in conjunction with NOTE parameters to determine DELAY L, DELAY R, and FB.DLY

1.  (Maximum value depends on the tempo setting)
2. For more information about the DELAY, NOTE, and TEMPO parameters, see “Setting Delay, Freq, Note & Tempo Parameters” on page 137.

**DELAY->ER.**

Delay and early reflections effects in series.

Parameter	Range	Description
DELAY L	0.0–1000.0 ms	Left channel delay time
NOTE L	*1	Used in conjunction with TEMPO to determine left channel DELAY L
FB.GAIN	–99 to +99%	Feedback gain (plus values for normal-phase feedback, minus values for reverse-phase feedback)
DELAY R	0.0–1000.0 ms	Right channel delay time
NOTE R	*1	Used in conjunction with TEMPO to determine right channel DELAY R
HI.RATIO	0.1–1.0	High-frequency feedback ratio
FB.DLY	0.0–1000.0 ms	Feedback delay time
NOTE FB	*1	Used in conjunction with TEMPO to determine FB.DLY
DLY BAL.	0–100%	Delay and early reflected delay balance (0% = early reflected delay, 100% = delay)
TYPE	S-Hall, L-Hall, Random, Revers, Plate, Spring	Type of early reflection simulation
ROOMSIZE	0.1–20.0	Reflection spacing
LIVENESS	0–10	Early reflections decay characteristics (0 = dead, 10 = live)
INI.DLY	0.0–500.0 ms	Initial delay before reverb begins
DENSITY	0–100%	Reverb density
ER NUM.	1–19	Number of early reflections
TEMPO*2	25–300 bps	Used in conjunction with NOTE parameters to determine DELAY L, DELAY R, and FB.DLY

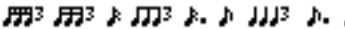
1.  (Maximum value depends on the tempo setting)
2. For more information about the DELAY, NOTE, and TEMPO parameters, see “Setting Delay, Freq, Note & Tempo Parameters” on page 137.

## DELAY+REV

Delay and reverb effects in parallel.

Parameter	Range	Description
DELAY L	0.0–1000.0 ms	Left channel delay time
NOTE L	*1	Used in conjunction with TEMPO to determine left channel DELAY L
FB.GAIN	–99 to +99%	Feedback gain (plus values for normal-phase feedback, minus values for reverse-phase feedback)
DELAY R	0.0–1000.0 ms	Right channel delay time
NOTE R	*1	Used in conjunction with TEMPO to determine right channel DELAY R
DLY HI	0.1–1.0	Delay high-frequency feedback ratio
FB.DLY	0.0–1000.0 ms	Feedback delay time
NOTE FB	*1	Used in conjunction with TEMPO to determine FB.DLY
DLY/REV	0–100%	Delay and reverb balance (0% = reverb, 100% = delay)
REV TIME	0.3–99.9 s	Reverb time
INI.DLY	0.0–500.0 ms	Initial delay before reverb begins
REV HI	0.1–1.0	High-frequency reverb time ratio
DENSITY	0–100%	Reverb density
HPF	Thru, 21 Hz–8.0 kHz	High-pass filter cutoff frequency
LPF	50 Hz–16.0 kHz, Thru	Low-pass filter cutoff frequency
TEMPO*2	25–300 bps	Used in conjunction with NOTE parameters to determine DELAY L, DELAY R, and FB.DLY

1.  (Maximum value depends on the tempo setting)
2. For more information about the DELAY, NOTE, and TEMPO parameters, see “Setting Delay, Freq, Note & Tempo Parameters” on page 137.

**DELAY->REV**

Delay and reverb effects in series.



Parameter	Range	Description
DELAY L	0.0–1000.0 ms	Left channel delay time
NOTE L	*1	Used in conjunction with TEMPO to determine left channel DELAY L
FB.GAIN	–99 to +99%	Feedback gain (plus values for normal-phase feedback, minus values for reverse-phase feedback)
DELAY R	0.0–1000.0 ms	Right channel delay time
NOTE R	*1	Used in conjunction with TEMPO to determine right channel DELAY R
DLY HI	0.1–1.0	Delay high-frequency feedback ratio
FB.DLY	0.0–1000.0 ms	Feedback delay time
NOTE FB	*1	Used in conjunction with TEMPO to determine FB.DLY
DLY BAL	0–100%	Delay and delayed reverb balance (0% = delayed reverb, 100% = delay)
REV TIME	0.3–99.9 s	Reverb time
INI.DLY	0.0–500.0 ms	Initial delay before reverb begins
REV HI	0.1–1.0	High-frequency reverb time ratio
DENSITY	0–100%	Reverb density
HPF	Thru, 21 Hz–8.0 kHz	High-pass filter cutoff frequency
LPF	50 Hz–16.0 kHz, Thru	Low-pass filter cutoff frequency
TEMPO*2	25–300 bps	Used in conjunction with NOTE parameters to determine DELAY L, DELAY R, and FB.DLY

1.  (Maximum value depends on the tempo setting)
2. For more information about the DELAY, NOTE, and TEMPO parameters, see “Setting Delay, Freq, Note & Tempo Parameters” on page 137.

## DIST->DELAY

Distortion and delay effects in series.

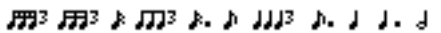
Parameter	Range	Description
DST TYPE	DST1, DST2, OVD1, OVD2, CRUNCH	Distortion type (DST = distortion, OVD = overdrive)
DRIVE	0–100	Distortion drive
MASTER	0–100	Master volume
TONE	–10 to +10	Tone control
N.GATE	0–20	Noise reduction
DLY BAL	0–100%	Distortion and delay balance (0% = distortion, 100% = delayed distortion)
DELAY	0.0–2725.0 ms	Delay time
DLY NOTE	*1	Used in conjunction with TEMPO to determine DELAY
FB.GAIN	–99 to +99%	Feedback gain (plus values for normal-phase feedback, minus values for reverse-phase feedback)
HI.RATIO	0.1–1.0	High-frequency feedback ratio
FREQ.	0.05–40.00 Hz	Modulation speed
MOD NOTE	*2	Used in conjunction with TEMPO to determine FREQ.
DEPTH	0–100%	Modulation depth
TEMPO* <sup>3</sup>	25–300 bps	Used in conjunction with NOTE parameters to determine DELAY and FREQ.

1.  (Maximum value depends on the tempo setting)
2. 
3. For more information about the DELAY, NOTE, and TEMPO parameters, see “Setting Delay, Freq, Note & Tempo Parameters” on page 137.

## MULTI FILTER

Three-band parallel filter (24 dB/octave)

Parameter	Range	Description
TYPE 1	HPF, LPF, BPF	Filter 1 type: low pass, high pass, band pass
TYPE 2	HPF, LPF, BPF	Filter 2 type: low pass, high pass, band pass
TYPE 3	HPF, LPF, BPF	Filter 3 type: low pass, high pass, band pass
FREQ. 1	28 Hz–16.0 kHz	Filter 1 frequency
FREQ. 2	28 Hz–16.0 kHz	Filter 2 frequency
FREQ. 3	28 Hz–16.0 kHz	Filter 3 frequency
LEVEL 1	0–100	Filter 1 level
LEVEL 2	0–100	Filter 2 level
LEVEL 3	0–100	Filter 3 level
RESO. 1	0–20	Filter 1 resonance
RESO. 2	0–20	Filter 2 resonance
RESO. 3	0–20	Filter 3 resonance



**FREEZE (Effect 2 only)**

Basic Sampler with 2.9 second memory.

Parameter	Range	Description
REC MODE	MANUAL, INPUT	In MANUAL mode, recording is started by pressing the [ENTER] button. In INPUT mode, recording is triggered by an input signal.
START	*1	Playback start point in milliseconds
[SAMPLE]	0–131070	Playback start point in samples
PLY MODE	MOMENT, CONTI., INPUT	In MOMENT mode, the sample plays for the moment that the [ENTER] button is pressed. In CONT. mode, playback continues once the [ENTER] button has been pressed. In INPUT mode, playback continues once it's been triggered by an input signal. The number of times the sample plays is set using the LOOP NUM parameter.
END	*1	Playback end point in milliseconds
[SAMPLE]	0–131070	Playback end point in samples
LOOP NUM	0–100	Number of times the sample plays
LOOP	*1	Loop start point in milliseconds
[SAMPLE]	0–131070	Loop start point in samples
TRG LVL	–60 to 0 dB	Input trigger level (i.e., the signal level required to trigger recording or playback)
TRG DLY	–1000 to +1000 ms	Recording delay. For plus values, recording starts after the trigger is received. For minus values, recording starts before the trigger is received.
TRG MASK	0–1000 ms	Once playback has been triggered, subsequent triggers are ignored for the duration of the TRG MASK time.
MIDI TRG	OFF, C1–C6, ALL	Sample playback can be triggered using MIDI Note on/off messages.
PITCH	–12 to +12 semitones	Playback pitch shift
FINE	–50 to +50 cents	Playback pitch shift fine

1. 0.0–2972.1 ms (fs=44.1 kHz), 0.0 ms–2730.6 ms (fs=48 kHz)

To record and playback a sample

1. **Send a channel signal to Effect 2, and then recall the Freeze effect.**  
See “Using the Effects” on page 123 and “Recalling Effects Programs” on page 134.
2. **Use the [EFFECT 2] button to locate EFFECT 2 page 1, as shown below.**



3. **Select the  (REC) switch, and then press the [ENTER] button. Note that the previous sampler is deleted at this point.**

The REC switch appears highlighted, and input signal can be heard.

4. Select the  (PLAY) switch, and press the [ENTER] button to start recording.

The bar below the REC and PLAY switches fills up as recording progresses.

With the REC MODE is set to INPUT, recording starts automatically when an input signal exceeds the TRG LVL.

5. To play back the sample, select the  (PLAY) switch, and then press the [ENTER] button.

With the PLY MODE is set to INPUT, playback starts automatically when an input signal exceeds the TRG LVL.

Use the PLY MODE parameters to set the type of playback, and the START, END, and LOOP parameters to edit the sample.

Be aware that samples are lost when another type of effect is recalled or the 01V is turned off.

# Effects Block Diagram

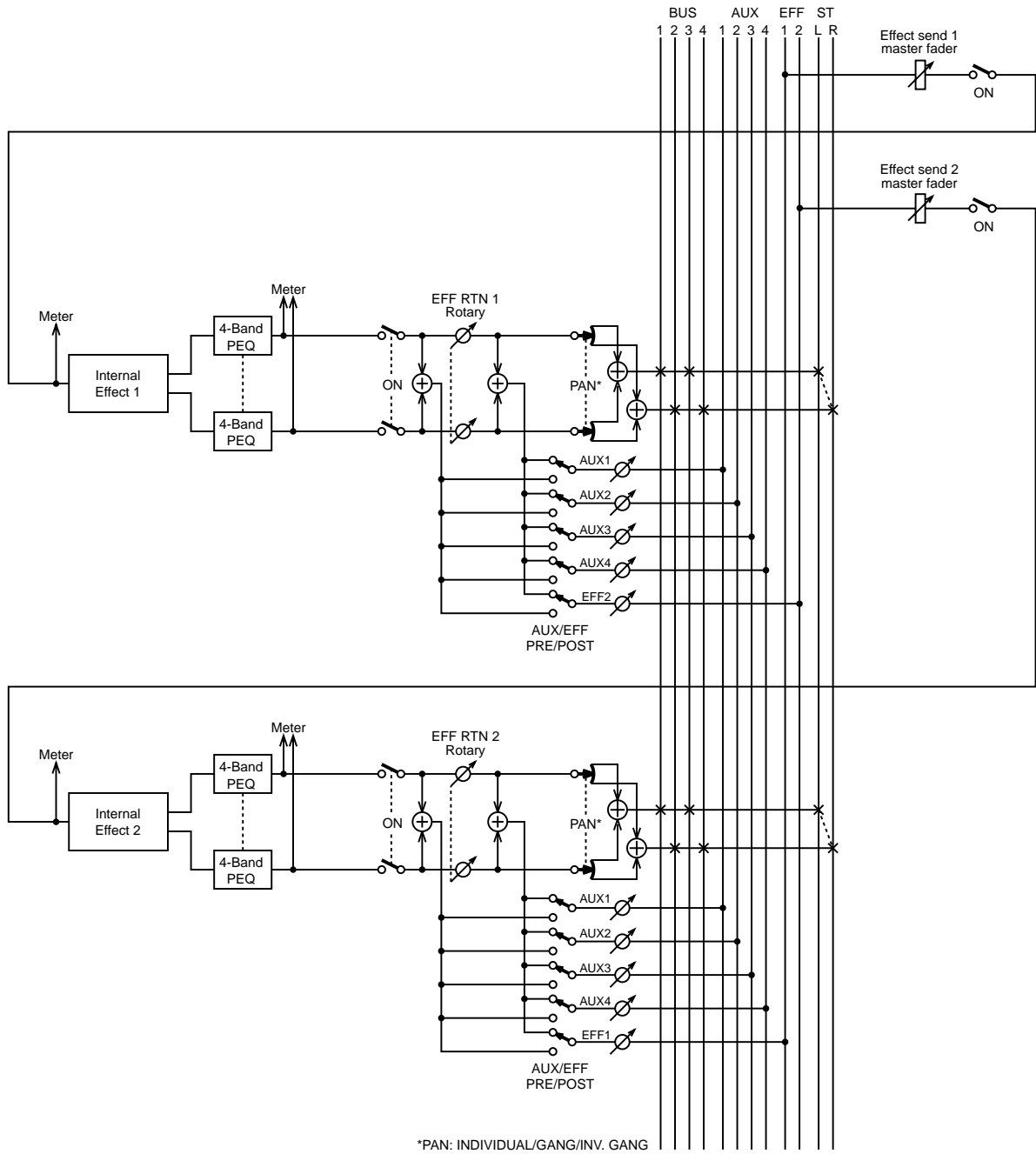

---

# Dynamics Processors

---

# 13

## In this chapter...

About the Dynamics Processors .....	162
Preset Dynamics Programs .....	163
Using the Dynamics Processors .....	164
Editing the Dynamics Processors .....	166
Processor Types .....	167
Dynamics Library .....	173
Storing Dynamics Programs .....	174
Recalling Dynamics Programs .....	175
Editing Dynamics Program Titles .....	176
Preset Dynamics Program Settings .....	177

## About the Dynamics Processors

Input channels 1 through 16, the aux sends, and the stereo output all feature powerful dynamics processors, offering compressor, limiter, gate, ducker, and compander functions. See the “Block Diagram” on page 24 for the exact location of each dynamics processor. Input channel processors can be self triggering (i.e., the signal being processed is used as the trigger signal), or triggered by a signal from another input channel.

Dynamics settings are stored as programs in the dynamics library, which contains 40 preset programs and 40 user programs. See “Dynamics Library” on page 173 for more information. Dynamics settings are also stored in scene memories. See “Storing Mix Scenes” on page 186 for more information.

Dynamics processors are edited on DYNAMICS page 1, as shown below. Use the [DYNAMICS] button to locate this page.

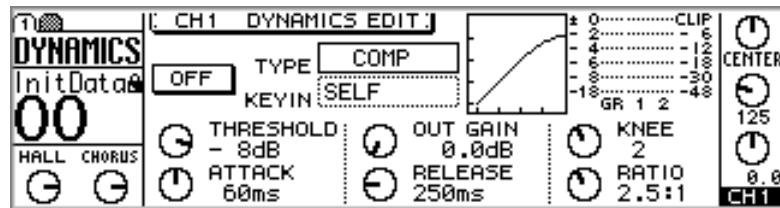

The name of the type of dynamics processor appears in the middle of the page next the dynamics curve. To the left is the processor on/off switch. Below these are the dynamics parameters, the number of which vary depending on the type of processor selected. The GR meter indicates the amount of gain reduction being applied to the selected channel. Next to this are level meters for the selected channel and its neighbor.

## Preset Dynamics Programs

The following table lists the preset dynamics programs. See “Preset Dynamics Program Settings” on page 177 for detailed parameter information.

No.	Title	Type
01	Comp	COMP
02	Gate	GATE
03	Expand	EXPAND
04	Ducking	DUCKING
05	Compander(H)	COMPAND-H
06	Compander(S)	COMPAND-S
07	A.Dr.BD	COMP
08	A.Dr.BD	GATE
09	A.Dr.BD	COMPAND-H
10	A.Dr.SN	COMP
11	A.Dr.SN	EXPAND
12	A.Dr.SN	GATE
13	A.Dr.SN	COMPAND-S
14	A.Dr.Tom	EXPAND
15	A.Dr.OverTop	COMPAND-S
16	E.B.Finger	COMP
17	E.B.Slap	COMP
18	Syn.Bass	COMP
19	Piano1	COMP
20	Piano2	COMP

No.	Title	Type
21	E.Guitar	COMP
22	A.Guitar	COMP
23	Strings1	COMP
24	Strings2	COMP
25	Strings3	COMP
26	BrassSection	COMP
27	Syn.Pad	COMP
28	SamplingPerc	COMPAND-S
29	Sampling BD	COMP
30	Sampling SN	COMP
31	Hip Comp	COMPAND-S
32	Solo Vocal1	COMP
33	Solo Vocal2	COMP
34	Chorus	COMP
35	Click Erase	EXPAND
36	Announcer	COMPAND-H
37	Limiter1	COMPAND-S
38	Limiter2	COMP
39	Total Comp1	COMP
40	Total Comp2	COMP

## Using the Dynamics Processors

Input channels 1 through 16, the aux sends, and the stereo output all feature dynamics processors.

To recall a program from the dynamics library, see “Recalling Dynamics Programs” on page 175. To edit a dynamics processor, see “Editing the Dynamics Processors” on page 166.

### For Input Channels 1–16

1. Use [SEL] buttons 1 through 16 to select channels.
2. Use the [DYNAMICS] button to locate DYNAMICS page 1, as shown below.

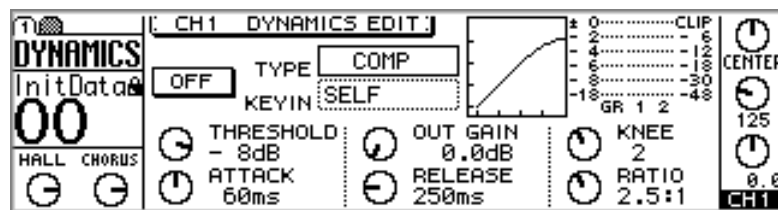

3. Press the [ENTER] button to turn on the dynamics processor.

The ON/OFF switch appears highlighted when the dynamics processor is on. While DYNAMICS page 1 is displayed, the [ENTER] button turns the dynamics processor on or off regardless of the cursor position.

4. Use the cursor buttons to select the parameters, and the PARAMETER wheel or [-1/DEC] and [+1/INC] buttons to set them.

The dynamics processors on input channels 13 and 14 (likewise 15 and 16) are permanently linked. When input channels 1 through 12 are paired (“Pairing Input Channels” on page 52), their dynamics processors are linked, so adjustments can be made with either channel selected.

### For Aux Sends 1–4

1. Use the [AUX] buttons to select an aux send, and then press the MASTER [SEL] button.

AUX appears on the display, indicating that an aux send is selected.

2. Use the [DYNAMICS] button to locate DYNAMICS page 1, as shown below.

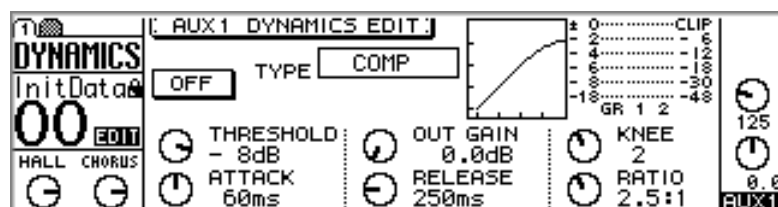

3. Press the [ENTER] button to turn on the dynamics processor.

The ON/OFF switch appears highlighted when the dynamics processor is on. While DYNAMICS page 1 is displayed, the [ENTER] button turns the dynamics processor on or off regardless of the cursor position.

4. Use the cursor buttons to select the parameters, and the **PARAMETER** wheel or **[-1/DEC]** and **[+1/INC]** buttons to set them.

When aux sends are paired (“Making Aux Send Pairs” on page 101), their dynamics processors are linked.

### For the Stereo Output

1. Press the **[HOME]** button, and then the **MASTER [SEL]** button.  
ST appears on the display, indicating that the stereo output is selected.
2. Use the **[DYNAMICS]** button to locate **DYNAMICS** page 1, as shown below.

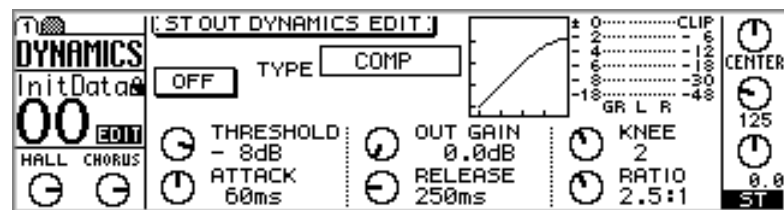

3. Press the **[ENTER]** button to turn on the dynamics processor.  
The ON/OFF switch appears highlighted when the dynamics processor is on. While **DYNAMICS** page 1 is displayed, the **[ENTER]** button turns the dynamics processor on or off regardless of the cursor position.
4. Use the cursor buttons to select the parameters, and the **PARAMETER** wheel or **[-1/DEC]** and **[+1/INC]** buttons to set them.



## Editing the Dynamics Processors

Dynamics processors are edited on the DYNAMICS page 1, as shown below.

1. Use the [DYNAMICS] button to locate DYNAMICS page 1, as shown below.

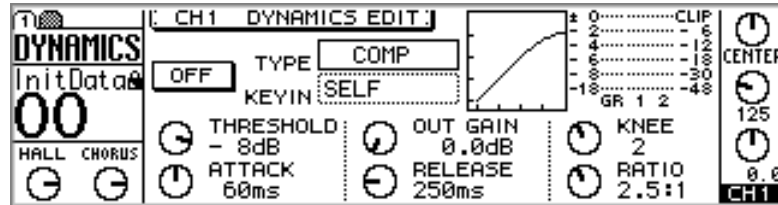

2. Use [SEL] buttons 1 through 16 and MASTER to select channels.
3. Use the cursor buttons to select the parameters, and the PARAMETER wheel or [-1/DEC] and [+1/INC] buttons to set them.

**TYPE**—This is the name of the type of dynamics processor currently selected: COMP, GATE, DUCKING, EXPAND, COMPANDER-(H), or COMPANDER-(S).

**ON/OFF**—This switch is used to turn on or off the dynamics processors. While DYNAMICS page 1 is displayed, the [ENTER] button turns the dynamics processor on or off regardless of the cursor position.

**KEY IN**—This parameter is used to select the trigger source for the dynamics processors, and can be set to SELF (i.e., the signal being processed is used as the trigger signal) or triggered by a signal from another input channel from CH1 through CH16.

**CURVE**—This window shows the curve of the dynamics processor, providing a visual indication of how it's set. The horizontal axis corresponds to the input signal and the vertical axis corresponds to the output signal.

A straight line at 45 degrees from the bottom left corner indicates that the input signal will pass through the dynamics processor unaffected. This can be seen when, for example, a compressor is set with a compression ratio of 1:1.

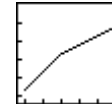

**PARAMETER**—These controls are used to adjust the dynamics processor's parameters. The number and type of parameters available depends on the type of dynamics processor selected.

**Meters**—The GR meter indicates the amount of gain reduction being applied to the selected channel. Next to this are level meters for the selected channel and its neighbor. The GR meter works from top to bottom. For the COMP, DUCKING, EXPAND, and COMPANDER types, the GR meter displays the amount of gain reduction. For the GATE type, the processor is active when the input signal is below the threshold, so the GR meter displays the amount of gain reduction when the input signal is below the threshold, and when there is no input signal.

The dynamics processors parameters are explained in detail on page 167.

# Processor Types

Dynamics processors are generally used to correct or control signal levels, although they can also be used creatively to shape a sound's volume envelope. The following sections explain the COMP, GATE, DUCKING, EXPAND, COMPANDER-(H), and COMPANDER-(S) dynamics processors, their parameters, and general applications.

## COMP

The COMP processor is a compressor that attenuates signals above a specified threshold, providing automatic level control. Vocalists that tend to move toward and away from the microphone while singing produce fluctuating signal levels; sometimes loud, sometimes soft. Likewise, acoustic instruments with a large dynamic range produce sound levels from *pianissimo* (very soft) through to *fortissimo* (very loud). In these situations, it is often difficult to set an average fader level that will allow a voice or instrument to be heard clearly throughout a song or piece of music. This is where the compressor comes in with automatic level control. By automatically reducing high levels, thus effectively reducing the dynamic range, the compressor makes it much easier to control signals and set appropriate fader levels. Reducing the dynamic range also means that recording levels can be set higher, therefore improving signal-to-noise performance.

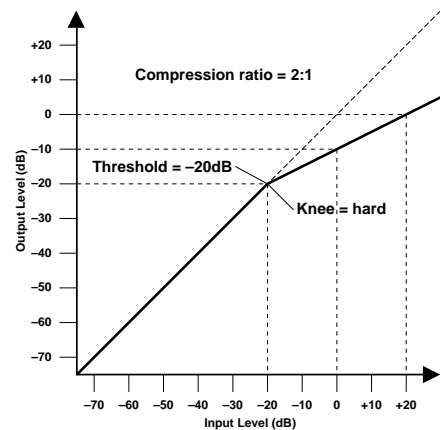

The COMP processor can also be used as a limiter, which is essentially a compressor with a high ratio setting. Compression ratios above 10:1 are considered to limit signals rather than compress them. When an input signal exceeds the specified threshold level, its level is automatically reduced to the threshold level. This means that the limiter's output level never actually exceeds the threshold level. Limiters are often used to prevent signals from overloading amplifiers and tape recorders. A limiter with a relatively high threshold, for example, could be used with the stereo outputs to prevent amplifier and speaker overload.

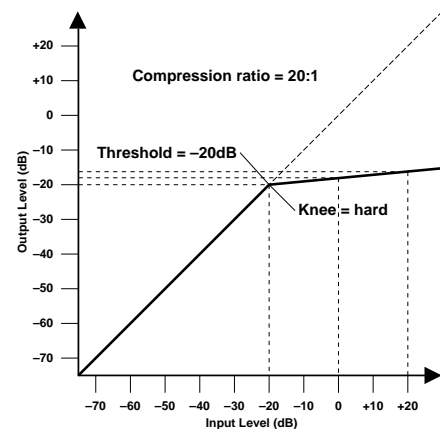

Parameter	Range
THRESHOLD	-54 dB to 0 dB (55 steps)
OUT GAIN	0.0 dB to +18.0 dB (0.5 dB steps)
KNEE	hard, 1, 2, 3, 4, 5
ATTACK	0–120 ms (1 ms steps)
RELEASE	5 ms–42.3 s (fs = 48 kHz) 6 ms–46 s (fs = 44.1 kHz)
RATIO	1:1, 1.1:1, 1.3:1, 1.5:1, 1.7:1, 2:1, 2.5:1, 3:1, 3.5:1, 4:1, 5:1, 6:1, 8:1, 10:1, 20:1, ∞:1 (16 steps)

**THRESHOLD**—This determines the level of input signal required to trigger the compressor. Signals at a level below the threshold pass through the compressor unaffected. Signals at and above the threshold level are compressed by the amount specified using the Ratio parameter. The trigger signal is sourced using the KEY IN parameter.

**OUT GAIN**—This sets the compressor’s output signal level, and can be used to compensate for the overall level change caused by the compression process.

**KNEE**—This determines how compression is applied at the threshold point. When set to hard, compression at the specified ratio is applied as soon as the input signal level exceeds the specified threshold. For knee settings from 1 to 5, however, compression is applied gradually as the signal exceeds the specified threshold, creating a more natural sound. This is called soft-knee compression.

**ATTACK**—This determines how soon the signal is compressed once the compressor has been triggered. With a fast attack time, the signal is compressed almost immediately. With a slow attack time, however, the initial transient of a sound passes through unaffected. Attack times from 1 to 5 milliseconds are a good place to start.

**RELEASE**—This determines how soon the compressor returns to its normal gain once the trigger signal level drops below the threshold. If the release time is too short, the gain will recover too quickly causing level pumping (i.e., noticeable gain fluctuations). If it is set too long, the compressor may not have time to recover before the next high level signal appears, and it will be compressed incorrectly. Release times from 0.1 to 0.5 seconds are a good place to start.

**RATIO**—This determines the amount of compression, that is, the change in output signal level relative to change in input signal level. For a 2:1 ratio, for example, a 10 dB change in input level (above the threshold) results in a 5 dB change in output level. For a 5:1 ratio, a 10 dB change in input level (above the threshold) results in a 2 dB change in output level.

## GATE

A gate, or noise gate is essentially an audio switch used to mute signals below a set threshold level. It can be used to cut background noise picked up by open microphones, noise and hiss from guitar valve amps and effects pedals, and leakage between drum microphones. It also has many creative uses too. For example, gating a drum sound with a short decay time tightens up the sound. Also, patching a gate into a droning bass synth channel and then triggering it from the kick drum channel allows the bass synth through only when the kick drum is struck, adding extra “oomph” on the beat.

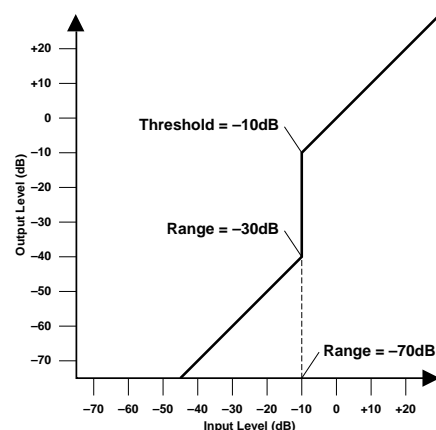

Parameter	Range
<b>THRESHOLD</b>	-54 dB to 0 dB (55 steps)
<b>RANGE</b>	-70 dB to 0 dB (71 steps)
<b>HOLD</b>	0.02 ms–1.96 s (fs = 48 kHz) 0.02 ms–2.13 s (fs = 44.1 kHz)
<b>ATTACK</b>	0–120 ms (1 ms steps)
<b>DECAY</b>	5 ms–42.3 s (fs = 48 kHz) 6 ms–46 s (fs = 44.1 kHz)

**THRESHOLD**—This determines the level at which the gate closes, cutting off the signal. Signals above the threshold level pass through unaffected. Signals at or below the threshold, however, cause the gate to close. The trigger signal is sourced using the KEY IN parameter.

**RANGE**—This determines the level to which the gate closes. Think of it as a brick holding a garden gate open so that a certain amount of signal always flows through. For a setting of  $-70$  dB, the gate closes completely when the input signal falls below the threshold. For a setting of  $-30$  dB, however, the gate half closes. For a setting of  $0$  dB, the gate has no effect. When signals are gated abruptly, the sudden disappearance can sometimes sound odd. This parameter causes the gate to reduce the signal level rather than cut it completely.

**HOLD**—This determines how long the gate stays open once the trigger signal has fallen below the threshold level.

**ATTACK**—This determines how fast the gate opens when the signal exceeds the threshold level. Slow attack times can be used to remove the initial transient edge of percussive sounds. Too slow an attack time makes some sounds appear backwards.

**DECAY**—This determines how fast the gate closes once the hold time has expired. A longer decay time produces a more natural gating effect, allowing the natural decay of an instrument to pass through. With a maximum decay time of between 42 and 63 seconds, you could even use this for fade-outs.

## DUCKING

Ducking is commonly used for voice-over applications in which the background music level is reduced automatically when an announcer speaks. Ducking is achieved by triggering a compressor with a different sound source. For example, a ducker is patched into the background music channel, and the KEY IN signal is sourced from the announcer’s microphone channel. When the announcer’s microphone level exceeds the specified threshold, the background music level is reduced automatically, allowing the announcer to be heard clearly. The same technique can also be used for vocals in a mix.

For example, ducking backing sounds such as rhythm guitar and synth pad during vocal phrases allows the vocals to be heard more clearly. This can also be used to bring solo instruments up in a mix.

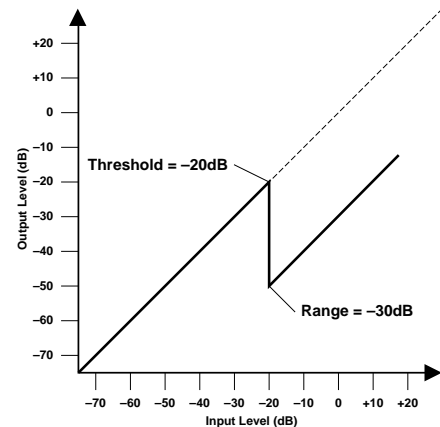

Parameter	Range
<b>THRESHOLD</b>	$-54$ dB to $0$ dB (55 steps)
<b>RANGE</b>	$-70$ dB to $0$ dB (71 steps)
<b>HOLD</b>	0.02 ms–1.96 s (fs = 48 kHz) 0.02 ms–2.13 s (fs = 44.1 kHz)
<b>ATTACK</b>	0–120 ms (1 ms steps)
<b>DECAY</b>	5 ms–42.3 s (fs = 48 kHz) 6 ms–46 s (fs = 44.1 kHz)

**THRESHOLD**—This determines the level of trigger signal (KEY IN) required to activate ducking. Trigger signal levels below the threshold do not activate ducking. Trigger signals at and above the threshold level, however, activate ducking, and the signal level

is reduced to a level set by the Range parameter. The trigger signal is sourced using the KEY IN parameter.

**RANGE**—This determines the level to which the signal is ducked. For a setting of  $-80$  dB, the signal is virtually cutoff. For a setting of  $-30$  dB, however, the signal is ducked by 30 dB. For a setting of 0 dB, the ducker has no effect.

**HOLD**— This determines how long ducking remains active once the trigger signal has fallen below the threshold level.

**ATTACK**—This determines how soon the signal is ducked once the ducker has been triggered. With a fast attack time, the signal is ducked almost immediately. With a slow attack time, however, ducking appears to fade the signal. Too fast an attack time may sound abrupt.

**DECAY**—This determines how soon the ducker returns to its normal gain once the trigger signal level drops below the threshold.

## EXPAND

An expander is similar to a compressor except that it works on signals below the threshold level. By reducing signals below the threshold level, the expander attenuates low-level noise, effectively increasing the dynamic range and improving the signal-to-noise performance. An expander set to an infinite ratio (i.e.,  $\infty:1$ ) is essentially a gate. The following two graphs show typical expander curves. The one on the left shows an expander with an expansion ratio of 2:1 and a hard knee setting. The one on the right shows an expander with an expansion ratio of 2:1 and a soft knee setting of 5.

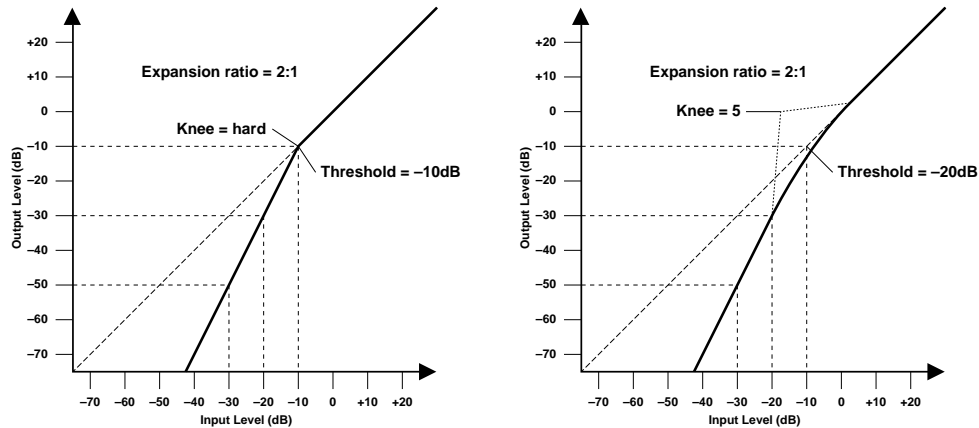

Parameter	Range
<b>THRESHOLD</b>	$-54$ dB to 0 dB (55 steps)
<b>OUT GAIN</b>	0.0 dB to +18.0 dB (0.5 dB steps)
<b>KNEE</b>	hard, 1, 2, 3, 4, 5
<b>ATTACK</b>	0–120 ms (1 ms steps)
<b>RELEASE</b>	5 ms–42.3 s ( $f_s = 48$ kHz) 6 ms–46 s ( $f_s = 44.1$ kHz)
<b>RATIO</b>	1:1, 1.1:1, 1.3:1, 1.5:1, 1.7:1, 2:1, 2.5:1, 3:1, 3.5:1, 4:1, 5:1, 6:1, 8:1, 10:1, 20:1, $\infty:1$ (16 steps)

**THRESHOLD**—This determines the level of input signal required to trigger the expander. Signals above the threshold pass through the expander unaffected. Signals at and below the threshold level are attenuated by the amount specified using the Ratio parameter. The trigger signal is sourced using the KEY IN parameter.

**OUT GAIN**—This sets the expander’s output signal level, and can be used to compensate for the overall level change caused by the expansion process.

**KNEE**—This determines how expansion is applied at the threshold point. When set to hard, expansion at the specified ratio is applied as soon as the input signal level falls below the specified threshold. For knee settings from 1 to 5, however, expansion is applied gradually as the signal falls below the specified threshold, creating a more natural sound.

**ATTACK**—This determines how soon the signal is expanded once the expander has been triggered. With a fast attack time, the signal is expanded almost immediately. With a slow attack time, however, the initial transient of a sound passes through unaffected. Attack times from 1 to 5 milliseconds are a good place to start.

**RELEASE**—This determines how soon the expander returns to its normal gain once the trigger signal level exceeds the threshold. If the release time is too short, the gain will recover too quickly causing level pumping (i.e., noticeable gain fluctuations). If it is set too long, the expander may not have time to recover before the next low-level signal appears, and it will be expanded incorrectly. Release times from 0.1 to 0.5 seconds are a good place to start.

**RATIO**—This determines the amount of expansion. That is, the change in output signal level relative to change in input signal level. For a 2:1 ratio, for example, a 5 dB change in input level (below the threshold) results in a 10 dB change in output level. For a 5:1 ratio, a 2 dB change in input level (below the threshold) results in a 10 dB change in output level.

## COMPANDER (HARD & SOFT)

The hard (H) and soft (S) companders comprise of compressor, expander, and limiter. The limiter prevents output signals from exceeding 0 dB. The compressor compresses signals that exceed the threshold level. The expander attenuates signals below the threshold and width. The soft compander has an expansion ratio of 1.5:1, while the hard compander has an expansion ratio of 5:1. The following two graphs show typical compander curves. The one on the left shows the hard compander. The one on the right, the soft compander.

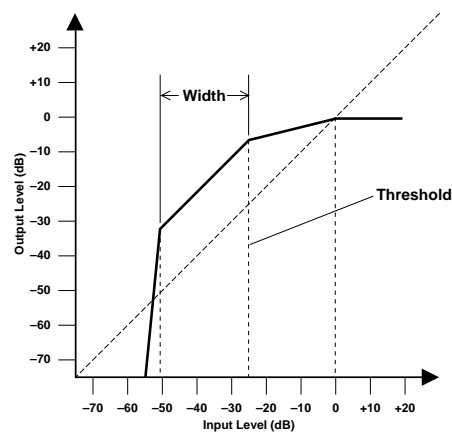

Hard Compander

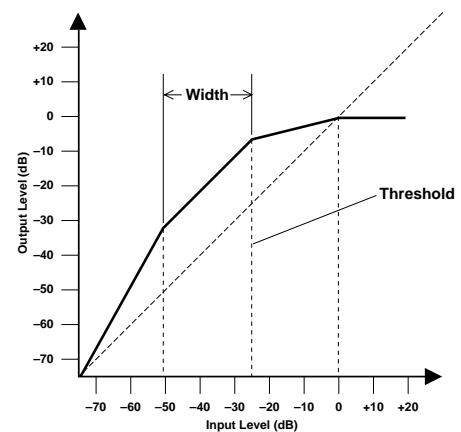

Soft Compander

Parameter	Range
<b>THRESHOLD</b>	–54 dB to 0 dB (55 steps)
<b>OUT GAIN</b>	–18 dB to 0 dB (0.5 dB steps)
<b>WIDTH</b>	1 dB–90 dB (1 dB steps)
<b>ATTACK</b>	0–120 ms (1 ms steps)
<b>RELEASE</b>	5 ms–42.3 s (fs = 48 kHz) 6 ms–46 s (fs = 44.1 kHz)
<b>RATIO</b>	1:1, 1.1:1, 1.3:1, 1.5:1, 1.7:1, 2:1, 2.5:1, 3:1, 3.5:1, 4:1, 5:1, 6:1, 8:1, 10:1, 20:1 (15 steps)

**THRESHOLD**—This determines the input signal level at which compression and expansion are applied. Signals at a level below the sum of the threshold and width are attenuated by the expander. Signals at and above the threshold level are compressed by the amount specified using the Ratio parameter. The trigger signal is sourced using the KEY IN parameter.

**OUT GAIN**—This sets the compander’s output signal level. It can be used to compensate for the overall level change caused by the compression and expansion processes.

**WIDTH**—This determines how far below the threshold level expansion is applied. The expander is essentially turned off when the width is set to 90 dB.

**ATTACK**—This determines how soon the signal is compressed and expanded once the compander has been triggered. With a fast attack time, the signal is compressed almost immediately. With a slow attack time, however, the initial transient of a sound passes through unaffected. Attack times from 1 to 5 milliseconds are a good place to start.

**RELEASE**—This determines how soon the compressor and expander return to their normal gains once the trigger signal level drops below the threshold. If the release time is too short, the gain will recover too quickly causing level pumping (i.e., noticeable gain fluctuations). If it is set too long, the compressor may not have time to recover before the next high level signal appears, and it will be compressed incorrectly. Release times from 0.1 to 0.5 seconds are a good place to start.

**RATIO**—This determines the amount of compression. That is, the change in output signal level relative to change in input signal level. For a 2:1 ratio, for example, a 10 dB change in input level (above the threshold) results in a 5 dB change in output level. For a 5:1 ratio, a 10 dB change in input level (above the threshold) results in a 2 dB change in output level. The expander ratios are fixed: 1.5:1 for the soft compander (S) and 5:1 for the hard compander (H).

## Dynamics Library

Dynamics settings are stored as programs in the dynamics library, which contains 40 preset programs (1–40) and 40 user programs (41–80). User programs are used to store custom dynamics settings, which can be titled for easy identification. The dynamics library can also be used to transfer settings from one dynamics processor to another. For example, the stereo out dynamics settings could be stored as a library program, and then recalled to an aux send dynamics processor. The unique collection of preset dynamics programs is designed for specific applications and instruments, and provides a good reference and starting point when using the dynamics processors. See page 177 for a complete list of the preset dynamics programs.

The dynamics library is controlled from the library page shown below. Use the [DYNAMICS] button to locate it.

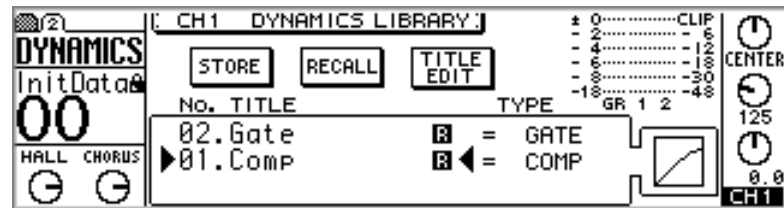

The top half of the library page contains the STORE, RECALL, and TITLE EDIT switches. Below these is the library window, which can be scrolled using the PARAMETER wheel. The “R” icon next to a preset program means read only. As each program is selected, its dynamics curve is displayed. The GR meter indicates the amount of gain reduction being applied to the selected channel. Next to this are level meters for the selected channel and its neighbor.



## Storing Dynamics Programs

Custom dynamics settings can be stored in user programs 41 through 80.

1. **Select the channel whose dynamics processor settings you want to store as a program.**

Use [SEL] buttons 1 through 16 to select the input channels 1 through 16. To select an aux send, use the [AUX] buttons to select an aux send, and then press the MASTER [SEL] button. To select the stereo output, press the [HOME] button, and then the MASTER [SEL] button.

2. **Use the [DYNAMICS] button to locate the Library page, as shown below.**

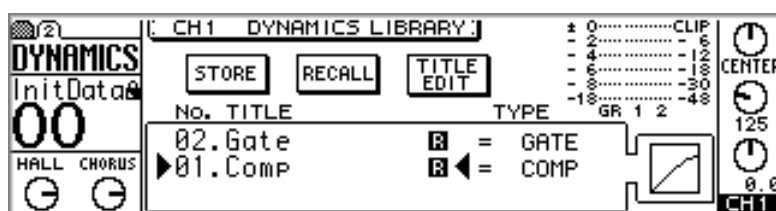

3. **Use the PARAMETER wheel or [-1/DEC] and [+1/INC] buttons to select a user program from 41 through 80.**

The program list order can be set using the LIBRARY LIST ORDER option in preferences (“Setting 01V Preferences” on page 203).

4. **Use the cursor buttons to select the STORE switch, and then press the [ENTER] button.**

The Title Edit dialog box appears. If the STORE CONFIRMATION option is turned off in the preferences (“Setting 01V Preferences” on page 203), the Title Edit dialog box does not appear and the dynamics program is stored.

5. **Title the dynamics program.**

See “Title Edit Dialog Box” on page 37 for more information.

6. **Select OK, and then press the [ENTER] button.**

The dynamics program is stored.

## Recalling Dynamics Programs

Dynamics programs 1 through 80 can be recalled.

- Select the channel to which you want to recall the dynamics program.**  
 Use [SEL] buttons 1 through 16 to select the input channels 1 through 16. To select an aux send, use the [AUX] buttons to select an aux send, and then press the MASTER [SEL] button. To select the stereo output, press the [HOME] button, and then the MASTER [SEL] button.
- Use the [DYNAMICS] button to locate the Library page, as shown below.**

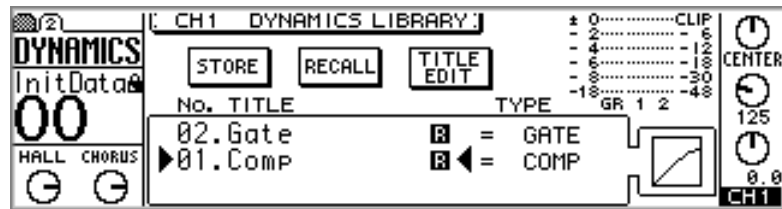

- Use the PARAMETER wheel or [-1/DEC] and [+1/INC] buttons to select programs.**

As each program is selected its dynamics curve is displayed.

The program list order can be set using the LIBRARY LIST ORDER option in preferences (“Setting 01V Preferences” on page 203).

- Use the cursor buttons to select the RECALL switch, and then press the [ENTER] button.**

The Dynamics program is recalled. If the RECALL CONFIRMATION option is turned on in the preferences (“Setting 01V Preferences” on page 203), a confirmation dialog box appears. In this case, select OK, and then press the [ENTER] button to confirm the recall.

## Editing Dynamics Program Titles

User program titles can be edited using the Title Edit function.

1. Use the [DYNAMICS] button to locate the Library page, as shown below.

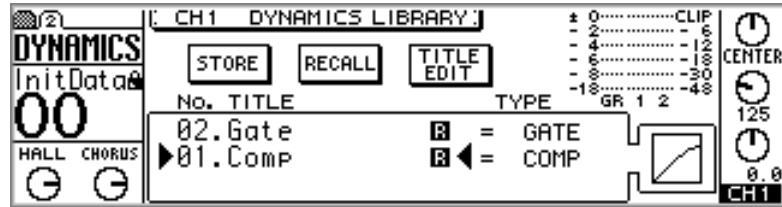

2. Use the PARAMETER wheel or [-1/DEC] and [+1/INC] buttons to select a user program from 41 through 80.
3. Use the cursor buttons to select the TITLE EDIT switch, and then press the [ENTER] button.

The Title Edit dialog box appears.

4. Edit the program title.  
See “Title Edit Dialog Box” on page 37 for more information.
5. Select OK, and then press the [ENTER] button.

The program is stored with its new title.

## Preset Dynamics Program Settings

#	Title	Type	Parameter	Value	Description
01	Comp	COMP	Threshold (dB)	-8	Compressor intended to reduce the overall volume level. Use it on the stereo output during mix-down. It can also be used with the stereo input.
			Ratio ( :1)	2.5	
			Attack (ms)	60	
			Out gain (dB)	0.0	
			Knee	2	
			Release (ms)	250	
02	Gate	GATE	Threshold (dB)	-26	Gate template.
			Range (dB)	-56	
			Attack (ms)	0	
			Hold (ms)	2.56	
			Decay (ms)	331	
03	Expand	EXPAND	Threshold (dB)	-23	Expander template.
			Ratio ( :1)	1.7	
			Attack (ms)	1	
			Out gain (dB)	3.5	
			Knee	2	
			Release (ms)	70	
04	Ducking	DUCKING	Threshold (dB)	-19	Ducking template.
			Range (dB)	-22	
			Attack (ms)	93	
			Hold (ms)	1.20 S	
			Decay (ms)	6.32 S	
05	Compander(H)	COMPAND-H	Threshold (dB)	-10	Hard-knee compressor template.
			Ratio ( :1)	3.5	
			Attack (ms)	1	
			Out gain (dB)	0.0	
			Width (dB)	6	
			Release (ms)	250	
06	Compander(S)	COMPAND-S	Threshold (dB)	-8	Soft-knee compressor template.
			Ratio ( :1)	4	
			Attack (ms)	25	
			Out gain (dB)	0.0	
			Width (dB)	24	
			Release (ms)	180	
07	A.Dr.BD	COMP	Threshold (dB)	-24	Compressor program for use with acoustic kit's bass drum.
			Ratio ( :1)	3	
			Attack (ms)	9	
			Out gain (dB)	5.5	
			Knee	2	
			Release (ms)	58	
08	A.Dr.BD	GATE	Threshold (dB)	-11	Gate program for use with acoustic kit's bass drum.
			Range (dB)	-53	
			Attack (ms)	0	
			Hold (ms)	1.93	
			Decay (ms)	400	

#	Title	Type	Parameter	Value	Description
09	A.Dr.BD	COMPAND-H	Threshold (dB)	-11	COMPAND-H program for use with acoustic kit's bass drum.
			Ratio (:1)	3.5	
			Attack (ms)	1	
			Out gain (dB)	-1.5	
			Width (dB)	7	
			Release (ms)	192	
10	A.Dr.SN	COMP	Threshold (dB)	-17	Compressor program for use with acoustic kit's snare drum.
			Ratio (:1)	2.5	
			Attack (ms)	8	
			Out gain (dB)	3.5	
			Knee	2	
			Release (ms)	12	
11	A.Dr.SN	EXPAND	Threshold (dB)	-23	Expander program for use with acoustic kit's snare drum.
			Ratio (:1)	2	
			Attack (ms)	0	
			Out gain (dB)	0.5	
			Knee	2	
			Release (ms)	151	
12	A.Dr.SN	GATE	Threshold (dB)	-8	Gate program for use with acoustic kit's snare drum.
			Range (dB)	-23	
			Attack (ms)	1	
			Hold (ms)	0.63	
			Decay (ms)	238	
13	A.Dr.SN	COMPAND-S	Threshold (dB)	-8	COMPAND-H program for use with acoustic kit's snare drum.
			Ratio (:1)	1.7	
			Attack (ms)	11	
			Out gain (dB)	0.0	
			Width (dB)	10	
			Release (ms)	128	
14	A.Dr.Tom	EXPAND	Threshold (dB)	-20	Expander program for use with acoustic kit's tom toms, which automatically reduces the volume when the tom toms are not played, helping to differentiate the bass and snare drums clearly.
			Ratio (:1)	2	
			Attack (ms)	2	
			Out gain (dB)	5.0	
			Knee	2	
			Release (ms)	749	
15	A.Dr.OverTop	COMPAND-S	Threshold (dB)	-24	Soft-knees compander program to emphasize the attack and ambience of cymbals recorded with overhead microphones. It automatically reduces the volume when the cymbals are not played, helping to differentiate the bass and snare drums clearly.
			Ratio (:1)	2	
			Attack (ms)	38	
			Out gain (dB)	-3.5	
			Width (dB)	54	
			Release (ms)	842	
16	E.B.Finger	COMP	Threshold (dB)	-12	Compressor program to level the attack and volume level of a finger-picked electric bass guitar.
			Ratio (:1)	2	
			Attack (ms)	15	
			Out gain (dB)	4.5	
			Knee	2	
			Release (ms)	470	

#	Title	Type	Parameter	Value	Description
17	E.B.Slap	COMP	Threshold (dB)	-12	Compressor program to level the attack and volume level of a slap electric bass guitar.
			Ratio ( :1)	1.7	
			Attack (ms)	6	
			Out gain (dB)	4.0	
			Knee	hard	
			Release (ms)	133	
18	Syn.Bass	COMP	Threshold (dB)	-10	Compressor program to control or emphasize the level of a synth bass.
			Ratio ( :1)	3.5	
			Attack (ms)	9	
			Out gain (dB)	3.0	
			Knee	hard	
			Release (ms)	250	
19	Piano1	COMP	Threshold (dB)	-9	Compressor program to brighten the tonal color of a piano.
			Ratio ( :1)	2.5	
			Attack (ms)	17	
			Out gain (dB)	1.0	
			Knee	hard	
			Release (ms)	238	
20	Piano2	COMP	Threshold (dB)	-18	A variation on program 19, using a deep threshold to change the entire attack and level.
			Ratio ( :1)	3.5	
			Attack (ms)	7	
			Out gain (dB)	6.0	
			Knee	2	
			Release (ms)	174	
21	E.Guitar	COMP	Threshold (dB)	-8	Compressor program for electric guitar cutting and arpeggio-style backing performance. The sound color can be varied using different playing styles.
			Ratio ( :1)	3.5	
			Attack (ms)	7	
			Out gain (dB)	2.5	
			Knee	4	
			Release (ms)	261	
22	A.Guitar	COMP	Threshold (dB)	-10	Compressor program for acoustic guitar stroke and arpeggio-style backing performance.
			Ratio ( :1)	2.5	
			Attack (ms)	5	
			Out gain (dB)	1.5	
			Knee	2	
			Release (ms)	238	
23	Strings1	COMP	Threshold (dB)	-11	Compressor program for strings.
			Ratio ( :1)	2	
			Attack (ms)	33	
			Out gain (dB)	1.5	
			Knee	2	
			Release (ms)	749	
24	Strings2	COMP	Threshold (dB)	-12	A variation on program 23, intended for violas or cellos.
			Ratio ( :1)	1.5	
			Attack (ms)	93	
			Out gain (dB)	1.5	
			Knee	4	
			Release (ms)	1.35 S	

#	Title	Type	Parameter	Value	Description
25	Strings3	COMP	Threshold (dB)	-17	A variation on program 23, intended for string instruments with a very low range, such as cellos or contrabass.
			Ratio (:1)	1.5	
			Attack (ms)	76	
			Out gain (dB)	2.5	
			Knee	2	
			Release (ms)	186	
26	BrassSection	COMP	Threshold (dB)	-18	Compressor program intended for brass sounds with a fast and strong attack.
			Ratio (:1)	1.7	
			Attack (ms)	18	
			Out gain (dB)	4.0	
			Knee	1	
			Release (ms)	226	
27	Syn.Pad	COMP	Threshold (dB)	-13	Compressor program for synth pad, intended to prevent diffusion of the sound.
			Ratio (:1)	2	
			Attack (ms)	58	
			Out gain (dB)	2.0	
			Knee	1	
			Release (ms)	238	
28	SamplingPerc	COMPAND-S	Threshold (dB)	-18	Compressor program for sampled sounds, making them as powerful as real acoustic drums. This program is for percussion sounds.
			Ratio (:1)	1.7	
			Attack (ms)	8	
			Out gain (dB)	-2.5	
			Width (dB)	18	
			Release (ms)	238	
29	Sampling BD	COMP	Threshold (dB)	-14	A variation on program 28, intended for sampled bass drum sounds.
			Ratio (:1)	2	
			Attack (ms)	2	
			Out gain (dB)	3.5	
			Knee	4	
			Release (ms)	35	
30	Sampling SN	COMP	Threshold (dB)	-18	A variation on program 28, intended for sampled snare drum sounds.
			Ratio (:1)	4	
			Attack (ms)	8	
			Out gain (dB)	8.0	
			Knee	hard	
			Release (ms)	354	
31	Hip Comp	COMPAND-S	Threshold (dB)	-23	A variation on program 28, intended for sampled sound loops.
			Ratio (:1)	20	
			Attack (ms)	15	
			Out gain (dB)	0.0	
			Width (dB)	15	
			Release (ms)	163	
32	Solo Vocal1	COMP	Threshold (dB)	-20	Compressor program suited for use with solo vocals.
			Ratio (:1)	2.5	
			Attack (ms)	31	
			Out gain (dB)	2.0	
			Knee	1	
			Release (ms)	342	

#	Title	Type	Parameter	Value	Description
33	Solo Vocal2	COMP	Threshold (dB)	-8	A variation on program 32.
			Ratio ( :1)	2.5	
			Attack (ms)	26	
			Out gain (dB)	1.5	
			Knee	3	
			Release (ms)	331	
34	Chorus	COMP	Threshold (dB)	-9	A variation on program 32, intended for chorus vocals.
			Ratio ( :1)	1.7	
			Attack (ms)	39	
			Out gain (dB)	2.5	
			Knee	2	
			Release (ms)	226	
35	Click Erase	EXPAND	Threshold (dB)	-33	Expander program to remove click track sounds that may bleed out of the musicians monitor headphones.
			Ratio ( :1)	2	
			Attack (ms)	1	
			Out gain (dB)	2.0	
			Knee	2	
			Release (ms)	284	
36	Announcer	COMPAND-H	Threshold (dB)	-14	Hard compander program to reduce the music level when the announcer speaks, making the voice clearer.
			Ratio ( :1)	2.5	
			Attack (ms)	1	
			Out gain (dB)	-2.5	
			Width (dB)	18	
			Release (ms)	180	
37	Limiter1	COMPAND-S	Threshold (dB)	-9	A soft-knee compander program with a slow release.
			Ratio ( :1)	3	
			Attack (ms)	20	
			Out gain (dB)	-3.0	
			Width (dB)	90	
			Release (ms)	3.90 s	
38	Limiter2	COMP	Threshold (dB)	0	A compressor program using the peak-stop style.
			Ratio ( :1)	∞	
			Attack (ms)	0	
			Out gain (dB)	0.0	
			Knee	hard	
			Release (ms)	319	
39	Total Comp1	COMP	Threshold (dB)	-18	Compressor intended to reduce the overall volume level. Use it on the stereo output during mix-down. It can also be used with the stereo input.
			Ratio ( :1)	3.5	
			Attack (ms)	94	
			Out gain (dB)	2.5	
			Knee	hard	
			Release (ms)	447	
40	Total Comp2	COMP	Threshold (dB)	-16	A variation on program 39 with greater compression.
			Ratio ( :1)	6	
			Attack (ms)	11	
			Out gain (dB)	6.0	
			Knee	1	
			Release (ms)	180	



---

# Scene Memories

---

# 14

## In this chapter...

About Scene Memories .....	184
What's Stored in Scene Memories? .....	184
About the Edit Buffer & Indicator .....	185
Scene Memory 00 .....	185
Scene Memory Display Area .....	185
Storing Mix Scenes .....	186
Recalling Mix Scenes .....	187
Recalling Mix Scenes Using MIDI Program Change Messages .....	188
Undoing Mix Scene Recalls .....	189
Protecting Scene Memories .....	189
Editing Scene Memory Titles .....	190
Renumbering Scene Memories .....	190
Setting a Fade Time .....	191
Recalling Scene Data Safely .....	192

## About Scene Memories

Scene memories are memory locations that are used to store mix scenes. A mix scene consists of all 01V mix settings (i.e., EQ, fader positions, effects, dynamics, and so on). There are 100 scene memories, and 1 through 99 can be titled for easy identification. The Recall Undo function can be used to undo accidental scene memory recalls, or for quick A/B mix comparisons. Crossfades from 0 to 25 seconds can be set up using the Fade Time function. Individual channels can be set as “safe channels” so their settings remain unchanged when a mix scene is recalled.

Scene memories can be stored and recalled in two ways:

- Manually on MEMORY page 1
- Remotely using MIDI Program Change messages from a computer or MIDI sequencer

Scene memory data can be backed up to an external MIDI device, such as a MIDI data filer, using MIDI Bulk Dump. See “Bulk Dump” on page 232 for more information. A scene memory to Program Change assignment table is provided on page 273.

Mix scenes are stored and recalled on MEMORY page 1, as shown below. Use the [MEMORY] button to locate it.

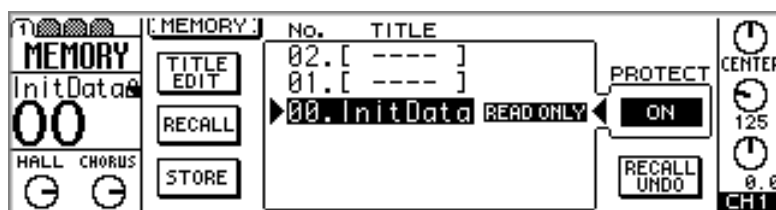

The area to the left of the page contains the TITLE EDIT, RECALL, and STORE switches. Next to these is the scene memory list, which can be scrolled using the PARAMETER wheel. If the INC/DEC MEMORY RECALL option is turned on in the preferences (“Setting 01V Preferences” on page 203), the [–1/DEC] and [+1/INC] buttons can also be used to select and recall scene memories. Scene memory 00 contains the initial settings and is a read-only memory, which means it can only be recalled. As each scene memory is selected, the PROTECT switch indicates whether or not it’s protected. Below this is the RECALL UNDO switch for undoing mix scene recalls. After initializing the 01V, the RECALL UNDO switch appears gray until a mix scene is recalled, because there is no data for undoing.

## What’s Stored in Scene Memories?

Virtually all 01V mix settings are stored in a scene memories. Settings that are not stored consist mainly of analog controls and switches. Namely, the 26 dB PAD switches, GAIN controls, 15/16–2TR IN switch, MONITOR–2TR IN switch, MONITOR OUT LEVEL control, PHONES LEVEL control, display contrast control, and on the rear panel, the phantom power switches.

In addition, the following data types are not stored: 01V Setup data, MIDI Program Change Map, MIDI Control Change Map, Scene Memory data, EQ library, Dynamics library, and Effects library. This data can be backed up to an external MIDI device, such as a MIDI data filer, using MIDI Bulk Dump. See “Bulk Dump” on page 232 for more information.

## About the Edit Buffer & Indicator

The Edit Buffer is the scene memory area inside the 01V that contains the current mix settings. When a mix scene is stored, the mix settings in the Edit Buffer are written to the selected scene memory. When a mix scene is recalled, the contents of the selected scene memory are placed in the Edit Buffer, making them the current mix settings.

When a parameter is adjusted after a mix scene has been recalled, the EDIT indicator appears in the Memory area of the display, indicating that the current mix settings (i.e., those in the Edit Buffer) no longer match those of the mix scene that was recalled last.



Scene memory 02 has just been recalled, so the contents of the Edit Buffer match those of scene memory 02.



The EDIT indicator means that a parameter has been changed since scene memory 02 was recalled, so the contents of the Edit Buffer no longer match those of scene memory 02.

The Edit Buffer settings are stored when the 01V is turned off, so they don't have to be stored to a scene memory before the 01V is turned off.

## Scene Memory 00

Scene memory 00 is a little different to scene memories 1 through 99 in that it's a read-only memory and contains the initial 01V settings. You can recall it, but you cannot store it. To reset all mix settings to their initial values, recall scene memory 00.

## Scene Memory Display Area

The scene memory area of the display shows the number and title of the selected scene memory, whether that scene memory is read only or write protected (indicated by the closed padlock icon), and whether or not the contents of the Edit Buffer have been edited. Scene memories from 1 to 99 can be protected individually against accidental overwriting. Scene memory 00 is a read only memory. When a scene memory other than the one recalled last is selected, the scene memory number flashes. If the scene memory that was recalled last is selected again, or a different scene memory is recalled, the number stops flashing. Also in the Memory area are the MIDI and HOST indicators, which appear when MIDI data is received at the MIDI IN or TO HOST port, respectively. See "MIDI Receive Indicators" on page 224 for more information.



## Storing Mix Scenes

Mix scenes can be stored in scene memories 1 through 99.

*Caution: When storing mix scenes, make sure that there are no mix settings in the Edit Buffer that you do not want to store. Perhaps some settings have been adjusted accidentally, or by someone else. If you are not sure of the Edit Buffer's exact contents, recall the last mix scene, make the adjustments that you really want, and then store the mix scene. You may want to store the current mix settings to an unused scene memory just in case.*

1. Use the [MEMORY] button to locate MEMORY page 1, as shown below.

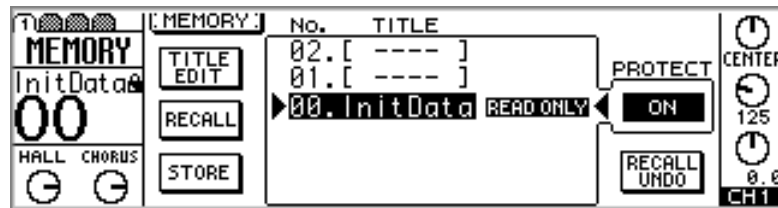

2. Use the PARAMETER wheel or [-1/DEC] and [+1/INC] buttons to select a scene memory from 1 through 99.

The scene memory list order can be set using the LIBRARY LIST ORDER option in preferences (“Setting 01V Preferences” on page 203).

3. Use the cursor buttons to select the STORE switch, and then press the [ENTER] button.

The Title Edit dialog box appears. If the STORE CONFIRMATION option is turned off in the preferences (“Setting 01V Preferences” on page 203), the Title Edit dialog box does not appear and the mix scene is stored.

4. Title the mix scene.

See “Title Edit Dialog Box” on page 37 for more information.

5. Select OK, and then press the [ENTER] button.

The mix scene is stored to the selected scene memory, the scene memory number stops flashing, and the EDIT indicator disappears.

## Recalling Mix Scenes

Mix scenes can be recalled from scene memories 0 through 99 manually, or remotely using MIDI Program Change messages.

*Note: When recalling mix scenes, be aware that volume levels may change suddenly as channels are turned on and fader levels adjusted. Nobody likes sudden loud noises, or speaker damage.*

1. Use the [MEMORY] button to locate MEMORY page 1, as shown below.

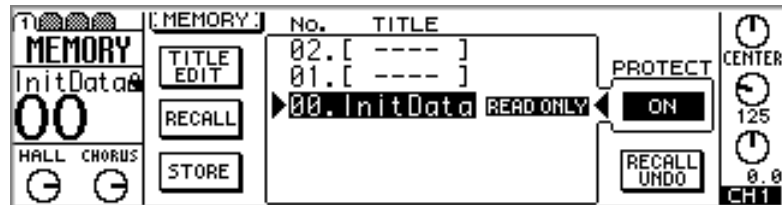

2. Use the PARAMETER wheel or [-1/DEC] and [+1/INC] buttons to select scene memories.

As each scene memory is selected, its title and number flash on the display.

The program list order can be set using the LIBRARY LIST ORDER option in preferences (“Setting 01V Preferences” on page 203).

3. Use the cursor buttons to select the RECALL switch, and then press the [ENTER] button.

The mix scene is recalled, the scene memory title and number stop flashing, and the EDIT indicator disappears.

If the RECALL CONFIRMATION option is turned on in the preferences (“Setting 01V Preferences” on page 203), a confirmation dialog box appears. In this case, select OK, and then press the [ENTER] button to confirm the recall.

If the INC/DEC MEMORY RECALL option is turned on in the preferences (“Setting 01V Preferences” on page 203), the [-1/DEC] and [+1/INC] buttons can be used to select and recall scene memories. As the [-1/DEC] or [+1/INC] button is pressed, subsequent scene memories that contain a mix scene are selected and recalled.

Mix scene recalls can be undone using the Recall Undo function. See “Undoing Mix Scene Recalls” on page 189 for more information.

## Recalling Mix Scenes Using MIDI Program Change Messages

MIDI Program Change messages can be used to recall mix scenes for snapshot-style mix automation. Program Change messages can be transmitted from a controlling computer, MIDI sequencer, or MIDI keyboard. Most MIDI keyboards, for example, transmit a Program Change message when a voice is selected. This could be used to recall a corresponding mix scene on the 01V, so that just one press of a button (or foot-switch), the synthesizer and 01V are reconfigured ready for the next song or scene.

To recall mix scenes using MIDI Program Change messages you must:

- 1. Connect MIDI equipment capable of transmitting Program Change messages to the 01V.**
- 2. Configure the 01V to receive MIDI Program Change messages. See “MIDI Setup” on page 224 for more information.**
- 3. Assign Program Change messages to scene memories. See “Program Change Scene Recall” on page 227 for more information.**

If the Program Change Tx switch is turned on (“MIDI Setup” on page 224), the 01V transmits a Program Change message each time a mix scene is recalled. This could be used to recall programs on other MIDI equipment, for example, effects program on an external effects processor, or a voice on a synthesizer. Recalling scene memory #10, for example, would recall voice #10 on a synthesizer. Program Change messages transmitted by the 01V can be recorded to a MIDI sequencer for automated scene changes.

## Undoing Mix Scene Recalls

Mix scene recalls can be undone using the Recall Undo function.

1. Use the [MEMORY] button to locate MEMORY page 1, as shown below.

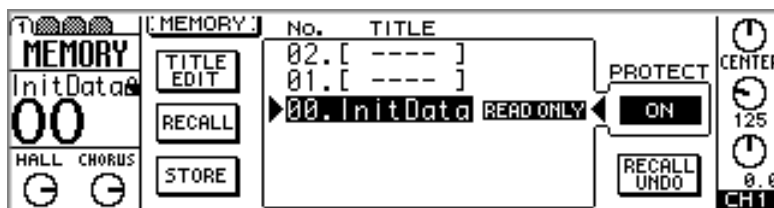

2. Use the cursor buttons to select the RECALL UNDO switch.

The RECALL UNDO switch appears gray until a mix scene is recalled after the 01V is initialized.

3. Press the [ENTER] button.

The 01V returns to the mix settings that were active before the mix scene was recalled. Pressing the [ENTER] button again redoes the mix scene recall. Pressing again undoes it, and so on.

Recall Undo is useful when a mix scene is recalled by mistake, but can also be used for A/B mix comparisons. To compare different mix settings, for example, store them to two scene memories. Recall one mix scene, and then the other. Recall Undo will then toggle between the two mixes.

## Protecting Scene Memories

Scene memories can be protected individually against accidental overwriting by using the Protect function. When a scene memory is protected, mix scenes cannot be stored in it, and scene memory data received via MIDI Bulk Dump is ignored.

1. Use the [MEMORY] button to locate MEMORY page 1, as shown below.

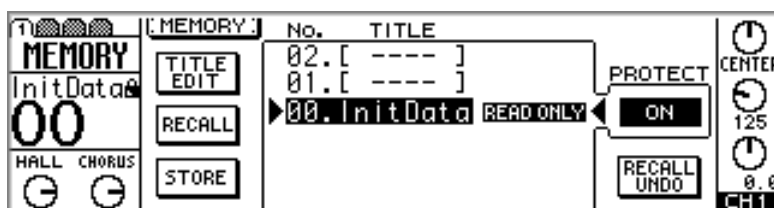

2. Use the PARAMETER wheel or [-1/DEC] and [+1/INC] buttons to select a scene memory.

Only scene memories that contain a mix scene can be protected.

3. Use the cursor buttons to select the PROTECT switch.

4. Press the [ENTER] button.

When a scene memory is protected, the word PROTECT appears next to it in the scene memory list and a closed padlock appears in the scene memory area on the display.

To turn off the protection, select the PROTECT switch, and then press the [ENTER] button.

## Editing Scene Memory Titles

Scene memory titles can be edited using the Title Edit function.

1. Use the [MEMORY] button to locate MEMORY page 1, as shown below.

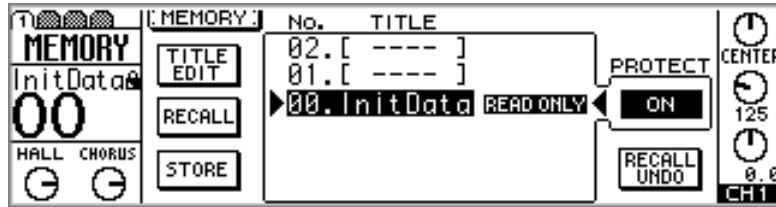

2. Use the PARAMETER wheel or [-1/DEC] and [+1/INC] buttons to select a scene memory.
3. Use the cursor buttons to select the TITLE EDIT switch, and then press the [ENTER] button.

The Title Edit dialog box appears.

4. Edit the scene memory title.  
See “Title Edit Dialog Box” on page 37 for more information.
5. Select OK, and then press the [ENTER] button.

The scene memory is stored with its new title.

## Renumbering Scene Memories

Scene memories can be renumbered by using the Sort function.

1. Use the [MEMORY] button to locate MEMORY page 3, as shown below.

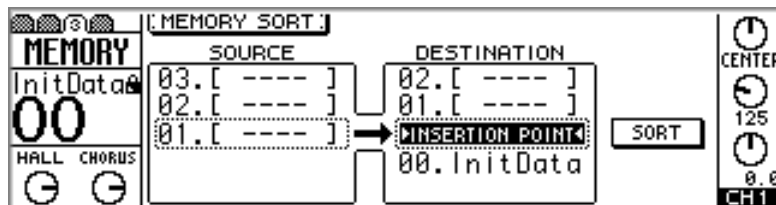

2. Use the cursor buttons to select the list on the left, and the PARAMETER wheel or [-1/DEC] and [+1/INC] buttons to select a scene memory.
3. Use the cursor buttons to select the list on the right, and the PARAMETER wheel or [-1/DEC] and [+1/INC] buttons to select the insertion point.
4. Use the cursor buttons to select the SORT switch, and then press the [ENTER] button.

The selected scene memory is renumbered.



## Setting a Fade Time

Using the Fade Time function, crossfades, fade outs, and fade ins from 0 to 25 seconds can be performed automatically by recalling mix scenes. Fade Time settings must be stored with a mix scene before they have any effect. Faders for input channels 1 through 16, the effects returns, aux send masters, bus out masters, and the stereo output can be enabled for fading individually.

1. Use the [MEMORY] button to locate MEMORY page 2, as shown below.

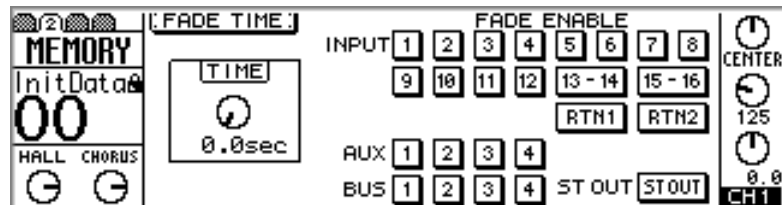

2. Use the cursor buttons to select the TIME control, and the PARAMETER wheel or [-1/DEC] and [+1/INC] buttons to set it.

The Fade Time can be set from 0 to 25 seconds in 0.1 second steps.

3. Use the cursor buttons to select the FADE ENABLE switches, and the [ENTER] button to enable channels for fading.

FADE ENABLE switches appear highlighted when channels are enabled for fading.

4. Store the current mix scene in a scene memory. See “Storing Mix Scenes” on page 186 for more information.

*Note: The Fade Time settings must be stored with a mix scene before they have any effect.*

5. Recall the mix scene. See “Recalling Mix Scenes” on page 187 for more information.

When the mix scene is recalled, enabled faders move to their new positions over the specified time. With a 5-second fade time, for example, it takes the enabled faders 5 seconds to reach their new positions. In a typical crossfade, one channel would fade out while another channel fades in.

## Recalling Scene Data Safely

When a mix scene is recalled, all mix settings are updated so that they match those of the recalled mix scene. In some cases, it may be necessary to retain mix settings of certain channels. This can be achieved using the Recall Safe function. Safe channels remain the same when mix scenes are recalled.

1. Use the [MEMORY] button to locate MEMORY page 4, as shown below.

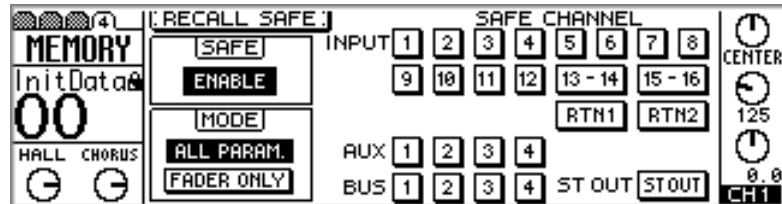

2. Use the cursor buttons to select the SAFE CHANNEL switches, and the [ENTER] button to set channels as safe.

SAFE CHANNEL switches appear highlighted for safe channels.

3. Use the cursor buttons to select a MODE (ALL PARAM or FADER ONLY), and the [ENTER] button to activate it.

In ALL PARAM mode, all parameters are safe. In FADER ONLY mode, only the faders are safe. All other parameters are updated when mix scenes are recalled.

4. Make sure the SAFE switch is set to ENABLE.

5. Use the cursor buttons to select the SAFE switch, and then press the [ENTER] button to enable the Recall Safe function.

The SAFE switch works as a master Recall Safe on/off, so you don't have to set individual channels when you want a scene recall to update all channels.

6. Recall a mix scene. See "Recalling Mix Scenes" on page 187 for more information.

When a mix scene is recalled, and providing that the SAFE switch is set to ENABLE, mix settings on safe channels remain the same.

If a mix scene containing paired channels, fader group, or mute group settings is recalled, and one of the channels in the pair or group is set as a safe channel, the pair or group is cancelled and only the non-safe channel is updated.

Recall Safe settings are not stored in mix scenes. They are, however, stored as part of the 01V Setup data. See "Bulk Dump" on page 232 for more information.

# Other Functions

---

# 15

## In this chapter...

Assigning Faders & On Buttons .....	194
Using the Oscillator .....	202
Setting 01V Preferences .....	203
Initializing the 01V .....	204
Calibrating the Faders .....	204

## Assigning Faders & On Buttons

The faders and [ON] buttons of input channels 1 through 16 and the stereo output (master) can be assigned functions other than their regular functions. Input channel faders 1 through 4, for example, can be used to control bus out master levels, which do not have their own dedicated faders. These assignments are active only when REMOTE page 1 is displayed. Select another page and the [ON] buttons and faders perform their regular functions. Four assignment sets can be stored in banks 1 through 4.

1. Use the [REMOTE] button to locate REMOTE page 1, as shown below.

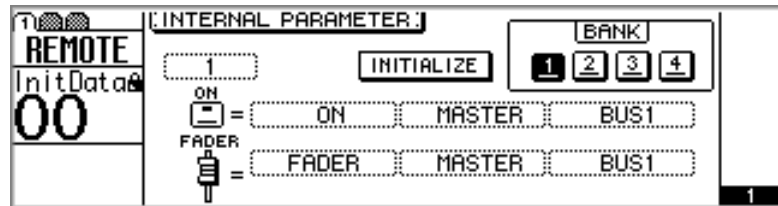

While this page is displayed, faders and [ON] buttons perform the functions assigned to them here, not their regular functions.

2. Use [SEL] buttons 1 through 16 and MASTER to select the channels whose [ON] buttons and faders you want to reassign.
3. Use the cursor buttons to select the parameters boxes, and the PARAMETER wheel or [-1/DEC] and [+1/INC] buttons to set them.

Available functions for the faders and [ON] buttons are listed in the subsequent tables.

4. Use the cursor buttons to select the BANK switches, and then press the [ENTER] button to activate the selected bank.

The switch of the active bank appears highlighted.

Custom assignments are stored in their respective banks when other banks are selected, and banks can be stored using MIDI Bulk Dump. See “Bulk Dump” on page 232 for more information.

To reset a bank back to its initial assignments, make it the active bank, select the INITIALIZE switch, and then press the [ENTER] button. A confirmation dialog box appears. Select OK, and then press the [ENTER] button to confirm your action. The selected bank is reset to its initial assignments.

## Fader Assignments

Faders 1 through 16 and master can be assigned to the following parameters.

	Parameter	Channel
NO ASSIGN	—	—
FADER	CHANNEL	CH1–12, CH13–14, CH15–16, CH17–24, RETURN1, RETURN2
	MASTER	AUX1–4, BUS1–4, EFFECT1, EFFECT2, ST OUT
	AUX1 SEND, AUX2 SEND	CH1–12, CH13–14, CH15–16, CH17–24, RETURN1, RETURN2
	AUX3 SEND, AUX4 SEND	CH1–12, CH13–14, CH15–16, RETURN1, RETURN2
	EFF1 SEND	CH1–12, CH13–14, CH15–16, CH17–24, RETURN2
	EFF2 SEND	CH1–12, CH13–14, CH15–16, CH17–24, RETURN1
DELAY	TIME	CH1–12, CH13–14, CH15–16, ST OUT L, ST OUT R, OMNI1–4
	MIX	
	FB GAIN	
EQ (F, G, Q)	F LOW	CH1–12, CH13–14, CH15–16, CH17–24, RETURN1, RETURN2, AUX1–4, ST OUT
	G LOW	
	Q LOW	
	F L-MID	CH1–12, CH13–14, CH15–16, RETURN1, RETURN2, AUX1–4, ST OUT
	G L-MID	
	Q L-MID	
	F H-MID	CH1–12, CH13–14, CH15–16, RETURN1, RETURN2, AUX1–4, ST OUT
	G H-MID	
	Q H-MID	
	F HIGH	CH1–12, CH13–14, CH15–16, CH17–24, RETURN1, RETURN2, AUX1–4, ST OUT
	G HIGH	
	Q HIGH	
	ATT	CH1–12, CH13–14, CH15–16, CH17–24
DYNAMICS	RATIO	CH1–12, CH13–14, CH15–16, AUX1–4, ST OUT
	KNEE/HOLD	
	THRESHOLD	
	ATTACK	
	G/RANGE	
	REL/DECAY	
EFFECT	EFFECT1	PARAM1–19
	EFFECT2	
PAN	CHANNEL	CH1–24, RETURN1 L, RETURN1 R, RETURN2 L, RETURN2 R
	AUX1, 2	
	AUX3, 4	CH1–16, RETURN1 L, RETURN1 R, RETURN2 L, RETURN2 R
	BUS TO ST	BUS1–4
	BALANCE	ST OUT

## On Button Assignments

On buttons 1 through 16 and master can be assigned to the following parameters.

	Parameter	Channel
<b>NO ASSIGN</b>	—	—
<b>ON (channel on/off)</b>	CHANNEL	CH1-12, CH13-14, CH15-16, CH17-24, RETURN1, RETURN2
	MASTER	AUX1-4, BUS1-4, EFFECT1, EFFECT2, ST OUT
	BUS TO ST	BUS1-4
<b>PHASE (normal/reverse)</b>	CHANNEL	CH1-16
<b>PRE/POST (pre/post)</b>	AUX1 SEND, AUX2 SEND	CH1-12, CH13-14, CH15-16, CH17-24, RETURN1, RETURN2
	AUX3 SEND, AUX4 SEND	CH1-12, CH13-14, CH15-16, RETURN1, RETURN2
	EFF1 SEND	CH1-12, CH13-14, CH15-16, CH17-24, RETURN2
	EFF2 SEND	CH1-12, CH13-14, CH15-16, CH17-24, RETURN1
<b>DELAY (on/off)</b>	CHANNEL	CH1-12, CH13-14, CH15-16
	OUTPUT	ST OUT L, ST OUT R, OMNI1-4
<b>EQ (on/off)</b>	CHANNEL	CH1-12, CH13-14, CH15-16, CH17-24, RETURN1, RETURN2
	OUTPUT	AUX1-4, ST OUT
<b>DYNAMICS (on/off)</b>	CHANNEL	CH1-12, CH13-14, CH15-16
	OUTPUT	AUX1-4, ST OUT

## Initial Assignments for Bank 1

These are the initial fader and [ON] button assignments for Bank 1.

Channel	Control	Parameter		
1	[ON] button	ON	MASTER	BUS1
	Fader	FADER	MASTER	BUS1
2	[ON] button	ON	MASTER	BUS2
	Fader	FADER	MASTER	BUS2
3	[ON] button	ON	MASTER	BUS3
	Fader	FADER	MASTER	BUS3
4	[ON] button	ON	MASTER	BUS4
	Fader	FADER	MASTER	BUS4
5	[ON] button	ON	MASTER	AUX1
	Fader	FADER	MASTER	AUX1
6	[ON] button	ON	MASTER	AUX2
	Fader	FADER	MASTER	AUX2
7	[ON] button	ON	MASTER	AUX3
	Fader	FADER	MASTER	AUX3
8	[ON] button	ON	MASTER	AUX4
	Fader	FADER	MASTER	AUX4
9	[ON] button	ON	MASTER	EFFECT1
	Fader	FADER	MASTER	EFFECT1
10	[ON] button	ON	MASTER	EFFECT2
	Fader	FADER	MASTER	EFFECT2
11	[ON] button	NO ASSIGN	—	—
	Fader	NO ASSIGN	—	—
12	[ON] button	NO ASSIGN	—	—
	Fader	NO ASSIGN	—	—
13–14	[ON] button	NO ASSIGN	—	—
	Fader	NO ASSIGN	—	—
15–16	[ON] button	NO ASSIGN	—	—
	Fader	NO ASSIGN	—	—
MAS	[ON] button	ON	MASTER	ST OUT
	Fader	FADER	MASTER	ST OUT

## Initial Assignments for Bank 2

These are the initial fader and [ON] button assignments for Bank 2.

Channel	Control	Parameter		
1	[ON] button	DELAY	CHANNEL	CH1
	Fader	DELAY	TIME	CH1
2	[ON] button	DELAY	CHANNEL	CH2
	Fader	DELAY	TIME	CH2
3	[ON] button	DELAY	CHANNEL	CH3
	Fader	DELAY	TIME	CH3
4	[ON] button	DELAY	CHANNEL	CH4
	Fader	DELAY	TIME	CH4
5	[ON] button	DELAY	CHANNEL	CH5
	Fader	DELAY	TIME	CH5
6	[ON] button	DELAY	CHANNEL	CH6
	Fader	DELAY	TIME	CH6
7	[ON] button	DELAY	CHANNEL	CH7
	Fader	DELAY	TIME	CH7
8	[ON] button	DELAY	CHANNEL	CH8
	Fader	DELAY	TIME	CH8
9	[ON] button	DELAY	CHANNEL	CH9
	Fader	DELAY	TIME	CH9
10	[ON] button	DELAY	CHANNEL	CH10
	Fader	DELAY	TIME	CH10
11	[ON] button	DELAY	CHANNEL	CH11
	Fader	DELAY	TIME	CH11
12	[ON] button	DELAY	CHANNEL	CH12
	Fader	DELAY	TIME	CH12
13-14	[ON] button	DELAY	CHANNEL	CH13-14
	Fader	DELAY	TIME	CH13-14
15-16	[ON] button	DELAY	CHANNEL	CH15-16
	Fader	DELAY	TIME	CH15-16
MAS	[ON] button	NO ASSIGN	—	—
	Fader	NO ASSIGN	—	—



## Initial Assignments for Bank 3

These are the initial fader and [ON] button assignments for Bank 3.

Channel	Control	Parameter		
1	[ON] button	NO ASSIGN	—	—
	Fader	EFFECT	EFFECT1	PARAM1
2	[ON] button	NO ASSIGN	—	—
	Fader	EFFECT	EFFECT1	PARAM2
3	[ON] button	NO ASSIGN	—	—
	Fader	EFFECT	EFFECT1	PARAM3
4	[ON] button	NO ASSIGN	—	—
	Fader	EFFECT	EFFECT1	PARAM4
5	[ON] button	NO ASSIGN	—	—
	Fader	EFFECT	EFFECT1	PARAM5
6	[ON] button	NO ASSIGN	—	—
	Fader	EFFECT	EFFECT1	PARAM6
7	[ON] button	NO ASSIGN	—	—
	Fader	EFFECT	EFFECT1	PARAM7
8	[ON] button	NO ASSIGN	—	—
	Fader	EFFECT	EFFECT1	PARAM8
9	[ON] button	NO ASSIGN	—	—
	Fader	EFFECT	EFFECT1	PARAM9
10	[ON] button	NO ASSIGN	—	—
	Fader	EFFECT	EFFECT1	PARAM10
11	[ON] button	NO ASSIGN	—	—
	Fader	EFFECT	EFFECT1	PARAM11
12	[ON] button	NO ASSIGN	—	—
	Fader	EFFECT	EFFECT1	PARAM12
13–14	[ON] button	NO ASSIGN	—	—
	Fader	EFFECT	EFFECT1	PARAM13
15–16	[ON] button	NO ASSIGN	—	—
	Fader	EFFECT	EFFECT1	PARAM14
MAS	[ON] button	NO ASSIGN	—	—
	Fader	EFFECT	EFFECT1	PARAM15

## Initial Assignments for Bank 4

These are the initial fader and [ON] button assignments for Bank 4.

Channel	Control	Parameter		
1	[ON] button	NO ASSIGN	—	—
	Fader	EFFECT	EFFECT2	PARAM1
2	[ON] button	NO ASSIGN	—	—
	Fader	EFFECT	EFFECT2	PARAM2
3	[ON] button	NO ASSIGN	—	—
	Fader	EFFECT	EFFECT2	PARAM3
4	[ON] button	NO ASSIGN	—	—
	Fader	EFFECT	EFFECT2	PARAM4
5	[ON] button	NO ASSIGN	—	—
	Fader	EFFECT	EFFECT2	PARAM5
6	[ON] button	NO ASSIGN	—	—
	Fader	EFFECT	EFFECT2	PARAM6
7	[ON] button	NO ASSIGN	—	—
	Fader	EFFECT	EFFECT2	PARAM7
8	[ON] button	NO ASSIGN	—	—
	Fader	EFFECT	EFFECT2	PARAM8
9	[ON] button	NO ASSIGN	—	—
	Fader	EFFECT	EFFECT2	PARAM9
10	[ON] button	NO ASSIGN	—	—
	Fader	EFFECT	EFFECT2	PARAM10
11	[ON] button	NO ASSIGN	—	—
	Fader	EFFECT	EFFECT2	PARAM11
12	[ON] button	NO ASSIGN	—	—
	Fader	EFFECT	EFFECT2	PARAM12
13–14	[ON] button	NO ASSIGN	—	—
	Fader	EFFECT	EFFECT2	PARAM13
15–16	[ON] button	NO ASSIGN	—	—
	Fader	EFFECT	EFFECT2	PARAM14
MAS	[ON] button	NO ASSIGN	—	—
	Fader	EFFECT	EFFECT2	PARAM15

## User Assignment table

Use this table for your own assignments.

Channel	Control	Parameter		
1	[ON] button			
	Fader			
2	[ON] button			
	Fader			
3	[ON] button			
	Fader			
4	[ON] button			
	Fader			
5	[ON] button			
	Fader			
6	[ON] button			
	Fader			
7	[ON] button			
	Fader			
8	[ON] button			
	Fader			
9	[ON] button			
	Fader			
10	[ON] button			
	Fader			
11	[ON] button			
	Fader			
12	[ON] button			
	Fader			
13-14	[ON] button			
	Fader			
15-16	[ON] button			
	Fader			
MAS	[ON] button			
	Fader			

## Using the Oscillator

The 01V features a useful audio oscillator with 100 Hz, 1 kHz, and 10 kHz sine wave tones and pink noise and burst pink noise. It can be assigned to individual aux sends, bus outs, effects sends, or the stereo output, and is useful for calibration or diagnostic purposes. Assigning burst noise to an effects send is a convenient way to audition reverb settings.

1. Use the [UTILITY] button to locate **UTILITY** page 1, as shown below.

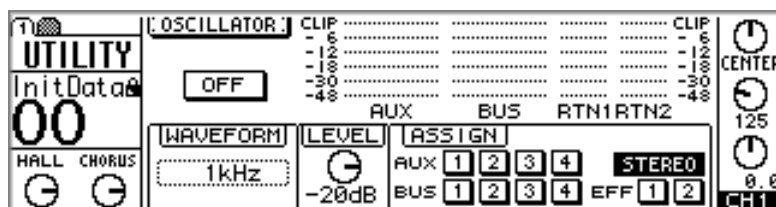

2. Use the cursor buttons to select the parameters, and the [ENTER] button, **PARAMETER** wheel, or [-1/DEC] and [+1/INC] buttons to set them.

**ON/OFF**—This switch is used to turn the oscillator on or off.

*Note: To prevent sudden tone-burst surprises in your monitors or headphones, set the oscillator level, stereo output, aux sends, bus outs, or effects returns to a minimal level.*

**WAVEFORM**—This switch is used to select the type of waveform generated by the oscillator: 100 Hz, 1 kHz, or 10 kHz sine wave tones, pink noise, or burst pink noise, which consists of 200 ms pulses at four second intervals.

**LEVEL**—This control is used to adjust the output level of the oscillator from 0 dB to -96 dB.

**ASSIGN**—These switches are used to assign the oscillator to individual aux sends, bus outs, effects sends, or the stereo output.

The Oscillator page also features level meters for the aux sends, bus outs, and effects returns.

When the oscillator is assigned to a bus, the oscillator signal has priority and other signals routed to that bus are muted.

## Setting 01V Preferences

The Preferences are used to customize the operation of the 01V.

1. Use the [UTILITY] button to locate UTILITY page 2 or 3, as shown below.

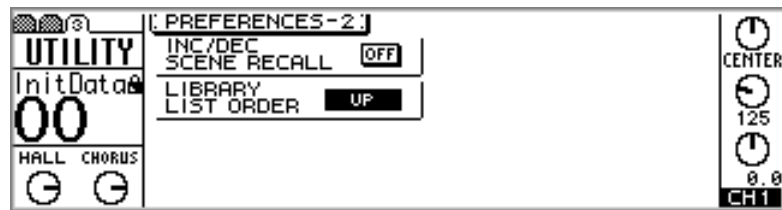

2. Use the cursor buttons to select the parameters, and the [ENTER] button, PARAMETER wheel, or [-1/DEC] and [+1/INC] buttons to set them.

**EQ AUTO SCREEN**—When this option is turned on, EQ page 1 or OPTION page 2 appears when the selected channel F or G control is adjusted, or the selected channel [HIGH], [HI-MID], [LO-MID], or [LOW] button is pressed. See “Adjusting the EQ” on page 63 for more information.

**PANPOT AUTO SCREEN**—When this option is turned on, PAN/ROUT page 1 or OPTION page 2 appears when the selected channel PAN control is adjusted. See “Panning Input Channels” on page 47 for more information.

**STORE CONFIRMATION**—When this option is turned on, the Title Edit dialog box, which also functions as a confirmation, appears whenever a mix scene or library program is stored; useful for preventing mix scenes and library programs from being stored accidentally.

**RECALL CONFIRMATION**—When this option is turned on, a confirmation dialog box appears whenever a mix scene or library program is recalled; useful for preventing mix scenes and library programs from being recalled accidentally.

**DIGITAL IN SYNC CAUTION**—When this option is turned on, a warning message appears if digital signals from the Digital Stereo Coaxial In or Option I/O inputs are not wordclock synchronized with the 01V. See “Setting the Wordclock” on page 209 for more information.

**“SELECTED CH” MESSAGE**—When this option is turned on, a message indicating the selected channel appears when the Fader mode is switched to and from Option I/O.

**DELAY UNITS**—Delay values for the input channel delay, stereo output delay, and omni out delay can be specified in milliseconds, meters, or samples. See “Delaying Channel Signals” on page 45, “Stereo Output Delay” on page 91, and “Omni Out Delay” on page 117.

**INC/DEC SCENE RECALL**—When this option is turned on, the [-1/DEC] and [+1/INC] buttons can be used to select and recall scene memories while MEMORY page 1 is displayed. As the [-1/DEC] or [+1/INC] button is pressed, subsequent scene memories that contain a mix scene are selected and recalled. See “Recalling Mix Scenes” on page 187 for more information.

**LIBRARY LIST ORDER**—When this option is set to UP, EQ, effects, dynamics, and scene memory lists appear with the lowest program/scene at the bottom and the highest at the top. When set to DOWN, they appear with the lowest at the top, highest at the bottom.

## Initial Settings

Preference	Options	Initial Setting
EQ AUTO SCREEN	ON/OFF	ON
PANPOT AUTO SCREEN	ON/OFF	ON
STORE CONFIRMATION	ON/OFF	ON
RECALL CONFIRMATION	ON/OFF	OFF
DIGITAL IN SYNC CAUTION	ON/OFF	ON
“SELECTED CH” MESSAGE	ON/OFF	ON
DELAY UNITS	msec, meter, sample	msec
INC/DEC SCENE RECALL	ON/OFF	OFF
LIBRARY LIST ORDER	UP/DOWN	UP

## Initializing the 01V

The Initialization function can be used to reset the 01V to its factory settings, clear all programs in the EQ, effects, and dynamics libraries, empty all scene memories, and reset the MIDI Program Change to scene memory, and Control Change to parameter assignment tables.

*Note: If you want to reset just the mix settings and retain the programs and scene memories, recall scene memory 00 instead. See “Scene Memory 00” on page 185 for more information.*

1. **Turn off the 01V.**
2. **While holding down the [MEMORY] button, turn on the 01V.**  
 <<INITIALIZE MEMORY?>> appears on the display.
3. **Release the [MEMORY] button.**
4. **Press the [+1/INC] to initialize the 01V, or the [-1/DEC] to cancel.**

If you choose to initialize the 01V, mix settings are reset to their factory settings, all programs in the EQ, effects, and dynamics libraries are cleared, the scene memories are emptied, and the faders are calibrated.

## Calibrating the Faders

If the 01V is not used for a long time, it’s moved to a new location, or fader movements have been obstructed, the faders may need calibrating. The calibration process calculates the torque required by each fader motor to drive its fader accurately and smoothly.

1. **Turn off the 01V.**
2. **While holding down the [ENTER] button, turn on the 01V.**
3. **Release the [ENTER] button.**

The fader calibration process starts. When the faders return to their original positions, calibration is complete. Do not attempt to use the 01V before calibration is completed.

---

# Using the Digital Inputs & Outputs

---

# 16

## In this chapter...

About Wordclocks .....	206
Setting the Wordclock .....	209
Digital Stereo Out .....	211
Output Dither .....	212
Digital Stereo In .....	213
Cascading 01Vs .....	214
About Option I/O Cards .....	216
Installing Option I/O Cards .....	218
Assigning Option I/O Digital Outputs .....	219
Option I/O Block Diagram .....	220

## About Wordclocks

Unlike analog audio equipment, digital audio equipment must be synchronized when digital audio is transferred from one device to another. Otherwise, the digital audio might not be read correctly and audible noise, glitches, or clicks may occur. Synchronization is achieved using what's called a *wordclock*, which is a clock signal for synchronizing all the digital audio words in an audio system. Note that wordclocks are not the same as SMPTE or MIDI timecode, which are used to synchronize audio recorders, MIDI sequencers, and so on. Wordclock synchronization refers to the synchronization of the digital audio processing circuits inside each digital audio device.

In a typical digital audio system, one device acts as the wordclock master and the other devices act as wordclock slaves that synchronize to the master wordclock signal. If the 01V is the only digital audio device in your system, no special wordclock settings are required and the 01V synchronizes to its own internal wordclock. Add a DAT recorder or digital multitrack recorder, however, and you must decide which device to use as wordclock master and which devices to use as slaves. Even when you've done this and configured your system, it may be necessary to change the wordclock settings in certain situations, such as when recording from a DAT or CD player.

The wordclock signal runs at the same frequency as the sampling rate. The 01V generates its own wordclock at 44.1 kHz (the industry-standard sampling rate for music CDs) and can be used as wordclock master. Alternatively, it can be used as a wordclock slave synchronized to an external wordclock of between 44.1 kHz  $-10\%$  and 48 kHz  $+6\%$ . Converting the sampling rate of digital audio is a complicated process, so it's best to use the 44.1 kHz sampling rate, especially if your work is destined for CD distribution.

Wordclock signals can be distributed via dedicated cables or derived from standard digital audio connections, as shown below. With AES/EBU and Coaxial digital audio connections, a wordclock signal is transmitted even when no audio signal is present.

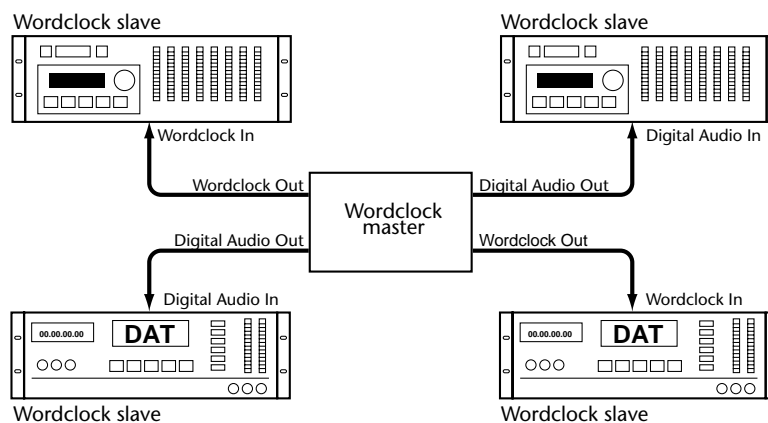

In a system where all devices share a common wordclock, it's important that all devices be turned on even when they're not being used. Turn on the wordclock master first, and then the slaves. When shutting down the system, turn off the slaves first, and then the master. Before commencing with a recording session, make sure that all wordclock slaves are synchronized to the master wordclock. Some devices have front panel indicators to show when they are wordclock synchronized. Refer to the instructions for each device.

The following system examples show three typical wordclock setups with the 01V. For detailed system examples with specific equipment, see "System Examples" on page 241.



## Digitally Recording to DAT

01V (wordclock master)

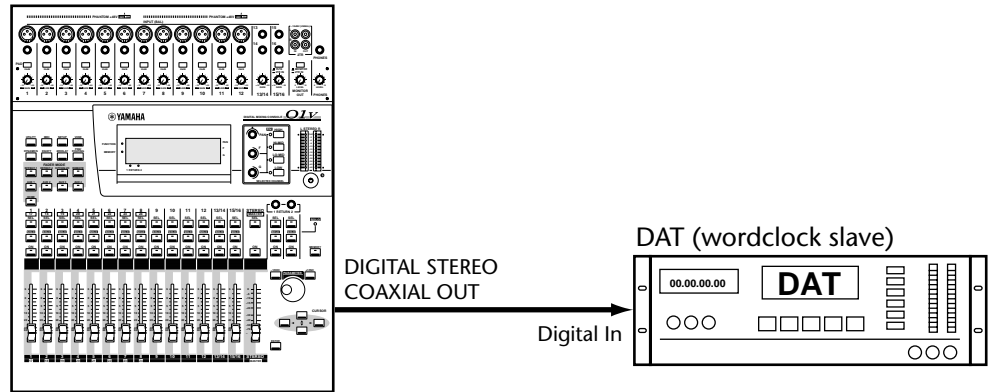

In this system, the 01V's stereo output signal is digitally transferred to a DAT recorder. The 01V works as wordclock master and the DAT works as wordclock slave. The 01V is set to internal wordclock. The DAT derives its wordclock signal from the Digital Stereo Coaxial Out connection of the 01V. Both devices operate at a sampling rate of 44.1 kHz.

## Multitrack Recording

01V (wordclock slave)

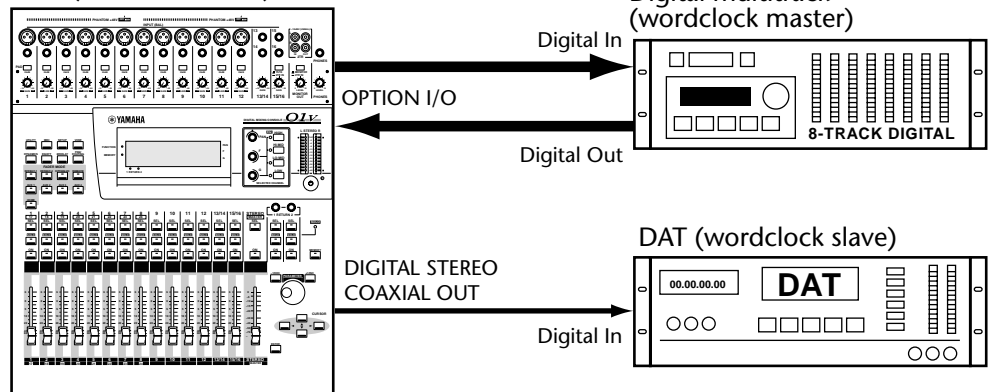

In this system, audio is recorded to, and mixed from the digital multitrack recorder. The 01V's stereo output signal is digitally transferred to the DAT recorder. The digital multitrack recorder is wordclock master and the 01V and DAT recorder are wordclock slaves. The 01V derives its wordclock from the Option I/O digital input. The DAT derives its wordclock signal from the Digital Stereo Coaxial Out connection of the 01V. The sampling rate is the same as that used when the digital multitrack tapes were formatted or recorded.

## Multitrack Recording with Digital DAT Source

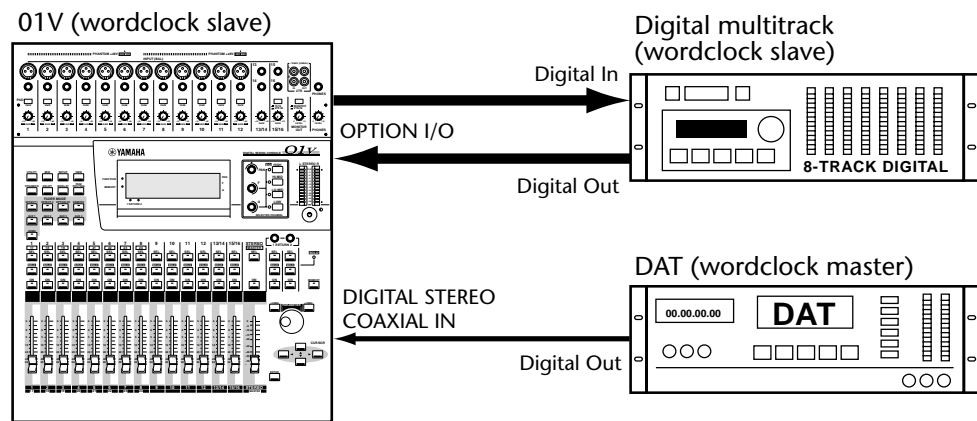

In this system, audio is recorded to, and mixed from the digital multitrack recorder. The DAT output signal is digitally transferred to the 01V for recording to the digital multitrack recorder. The DAT recorder is wordclock master and the 01V and digital multitrack recorder are wordclock slaves. The 01V derives its wordclock from the Digital Stereo Coaxial In connection. The digital multitrack recorder derives its wordclock from the 01V's Option I/O connection. The sampling rate is the same as that used when the DAT tape was recorded. A CD player could be connected instead of the DAT recorder. In this case, the sampling rate would be fixed at 44.1 kHz, the industry-standard sampling rate for music CDs.

## Setting the Wordclock

The 01V can generate its own internal wordclock at 44.1 kHz (the industry-standard sampling rate for music CDs) or synchronize to an external wordclock of between 44.1 kHz  $-10\%$  and 48 kHz  $+6\%$ , which can be sourced from the Digital Stereo In or a digital Option I/O card.

*Note: If the 01V is the only digital audio device in your system, you do not need to change the wordclock source. It can be left at internal 44.1 kHz.*

1. Use the [SETUP] button to locate **SETUP page 1**, as shown below.

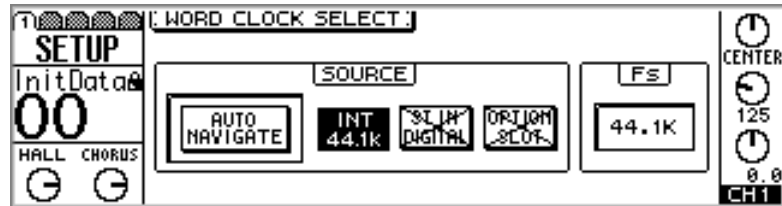

*Note: When the wordclock source is changed, audible glitches or clicks may be produced, so it's a good idea to turn down the volume on all monitor amps and headphones first.*

2. Use the cursor buttons to select the **SOURCE** switches, and the [ENTER] button to set them.

**AUTO NAVIGATE**—This function checks all possible wordclock sources and then displays a dialog box recommending a suitable source. Note that in some situations this function may not be able to recommend a suitable source. The following dialog box appears when this function is run. Select OK, and press the [ENTER] button to start digital input scanning.



To select the wordclock source manually, use the following switches.



This switch selects the internal 44.1 kHz wordclock. A highlighted switch like the one shown here indicates that the 01V is synchronized to the wordclock source and ready for use.



This switch selects the Digital Stereo In as the wordclock source. A switch like the one shown here with a single diagonal line indicates that a wordclock signal is present at this input but the 01V is not synchronized to it.



This switch selects the Option I/O card as the wordclock source. A switch like the one shown here with two diagonal lines indicates that no wordclock signal is present at this input.



A highlighted switch with two diagonal lines like the one shown here indicates that no wordclock is being received from the selected source, and the Fs window will probably show UNLOCK. Before using the 01V, correct the external wordclock, or select another source. This condition typically occurs when the external wordclock source is turned off, or the cable carrying the wordclock signal has been disconnected.

If the DIGITAL IN SYNC CAUTION option is turned on in the preferences (“Setting 01V Preferences” on page 203), a warning message appears if digital signals from the Digital Stereo Coaxial In or Option I/O inputs are not wordclock synchronized with the 01V. If this message appears, configure the external device as wordclock master.

When an MY8-AE Option I/O card is installed, the OPTION SLOT switch is replaced by four SLOT switches, as shown below.

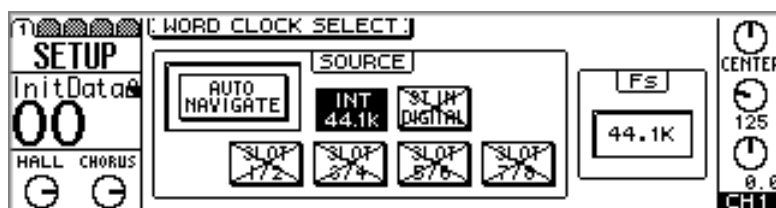

These switches are used to select a pair of AES/EBU digital inputs as the wordclock source.

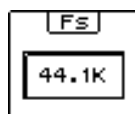

This window displays the status of the 01V wordclock. 44.1k indicates that the 01V is locked to a sampling rate of 44.1 kHz. When the wordclock source is changed, the word LOCK appears, indicating that the 01V is in the process of locking to the new source. If the external wordclock source is lost, the word UNLOCK appears. This condition typically occurs when the external wordclock source is turned off or the cable carrying the wordclock signal has been disconnected.

When a CD player is connected to the Digital Stereo In, the only available sampling rate is 44.1 kHz. When a DAT is connected, the sampling rate is determined by the DAT. Some DATs record at a fixed sampling rate, while others allow the user to choose, typically between 44.1 kHz and 48 kHz.

## Digital Stereo Out

The stereo output signal is output digitally in Consumer format from the Digital Stereo Out Coaxial connector. Typically this is connected to the digital input on a DAT or MiniDisc deck for stereo mix recording, or the Digital Stereo In of another 01V for cascade operation. See “Cascading 01Vs” on page 214 for more information. The wordlength of the Digital Stereo Out Coaxial signal is set using the Dither function. See “Output Dither” on page 212 for more information.

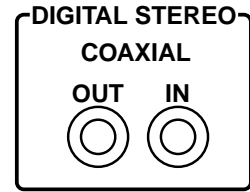

In the following example, the Digital Stereo Coaxial Out on the 01V is connected to the digital input of a DAT recorder for digital mixdown recording. The 01V works as wordclock master, while the DAT works as wordclock slave. See “About Wordclocks” on page 206 for more information. When the digital input on the DAT recorder is selected as the recording source, the DAT should automatically synchronize to the wordclock signal coming from the 01V. On some DAT recorders, the wordclock source may have to be set separately. Refer to the instructions supplied with your DAT recorder.

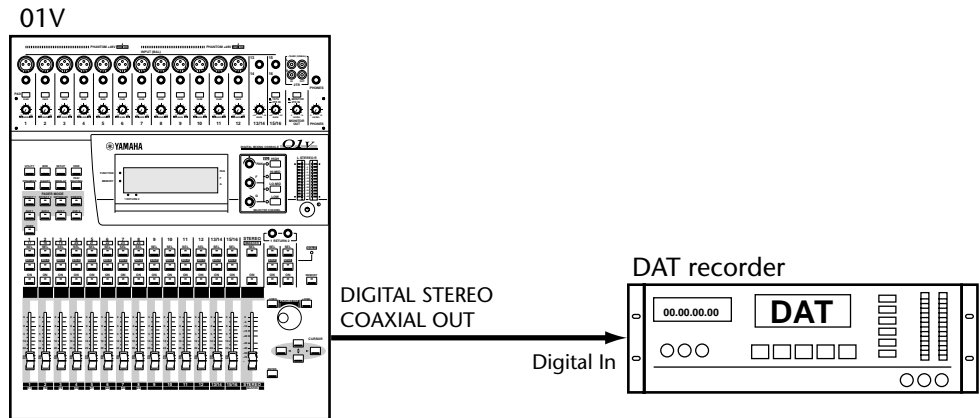

## Output Dither

When a high-resolution digital audio signal is transferred to a lower-resolution system, some of the least-significant bits (LSB) of data are ignored by the receiving system, which can make low-level signals sound grainy and step like, similar to the noise produced by a low-resolution digital reverb as signals fade. To prevent this, the wordlength of a digital audio signal can be shortened to match that of the receiving system. Instead of simply chopping the unwanted bits off, the 01V uses the industry-standard technique known as *dither* is used to optimize the wordlength reduction process.

Dither can be set independently for the Digital Stereo Out and Option I/O digital outputs, and should be matched to the wordlength supported by the receiving digital audio device. For example, with a 16-bit DAT recorder connected to the Digital Stereo Out, the DIGITAL ST OUT should be set to a wordlength of 16, and with a 20-bit digital multitrack recorder connected via the Option I/O, OPTION OUT should be set to 20.

1. Use the [SETUP] button to locate **SETUP** page 5, as shown below.

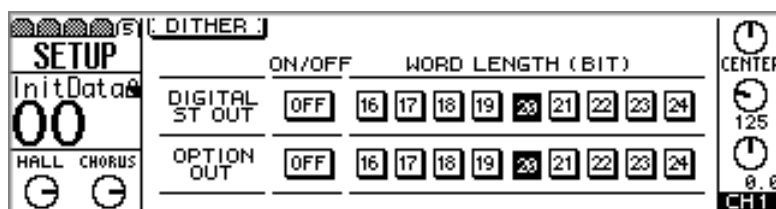

2. Use the cursor buttons to select the **WORD LENGTH** switches, and the [ENTER] button to set them.

Dither works by comparing the output of a special pseudorandom number sequence generator with the lowest data bit of the shortened data word and the unwanted data bits. The lowest bit is then rounded up or down prior to D/A conversion, thereby optimizing the digital output signal for use with lower-resolution systems. Since dither endows the digital signal with a noise floor close to the minimum theoretical limit, some audio professionals choose not to use it for applications with a wide dynamic range, such as classical recording. If you're in any doubt, it's probably best to use it.

## Digital Stereo In

Consumer format digital audio signals can be connected to the 01V using the Digital Stereo In Coaxial connection. The digital output of a CD player, DAT, or MiniDisc deck could be connected here, or the Digital Stereo Out of another 01V for cascade operation. See “Cascading 01Vs” on page 214 for more information.

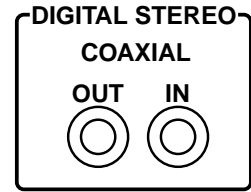

1. Use the [PAN/ROUTING] button to locate PAN/ROUT page 4, as shown below.

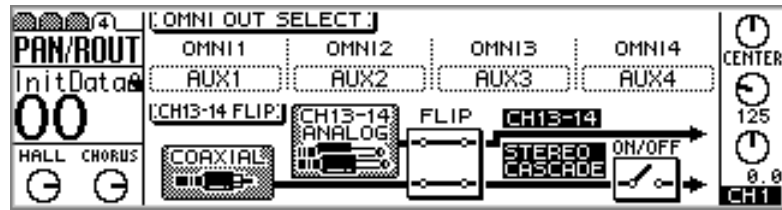

2. Use the cursor buttons to select the FLIP and ON/OFF switches, and the [ENTER] button to set them.

**FLIP**—This switch is used to flip the inputs of input channels 13 and 14 with the Digital Stereo In. Normally, analog inputs 13 and 14 feed input channels 13 and 14, and the Digital Stereo In feeds the Stereo bus. When flipped, analog inputs 13 and 14 feed the Stereo bus, and the Digital Stereo In feeds input channels 13 and 14.

**ON/OFF**—This switch is used to turn on or off the stereo cascade signal. The source of the stereo cascade signal is set by the FLIP switch. The stereo cascade signal can be monitored pre or post this switch using the monitors or phones. See “Monitor Setup” on page 78 for more information.

*Note: To prevent noise when using the Digital Stereo In connection, the source device and the 01V must be wordclock synchronized. See “About Wordclocks” on page 206 for more information.*

Digital audio signals containing emphasis are automatically deemphasized.

In the following example, the Digital Stereo Coaxial In on the 01V is connected to the digital output of a DAT recorder for mixing from a digital source. The 01V works as wordclock slave, while the DAT works as wordclock master. On 01V SETUP page 1, set the wordclock source to ST IN DIGITAL. See “Setting the Wordclock” on page 209 for more information.

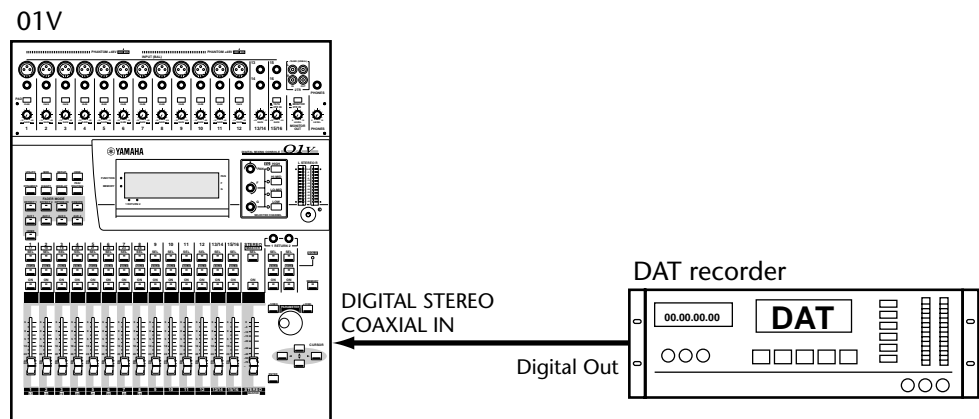

## Cascading 01Vs

By using the Stereo Digital In and Stereo Digital Out connections, two 01Vs can be cascaded together for 48-channel digital mixing, as shown below. 01V-A audio signals are combined into a stereo mix that is then sent to 01V-B via the Digital Stereo Coaxial connections and mixed with the audio signals of 01V-B. 01V-A works as wordclock master and is set to INT 44.1K, while 01V-B works as wordclock slave with its wordclock source set to ST IN DIGITAL. See “Setting the Wordclock” on page 209 for more information.

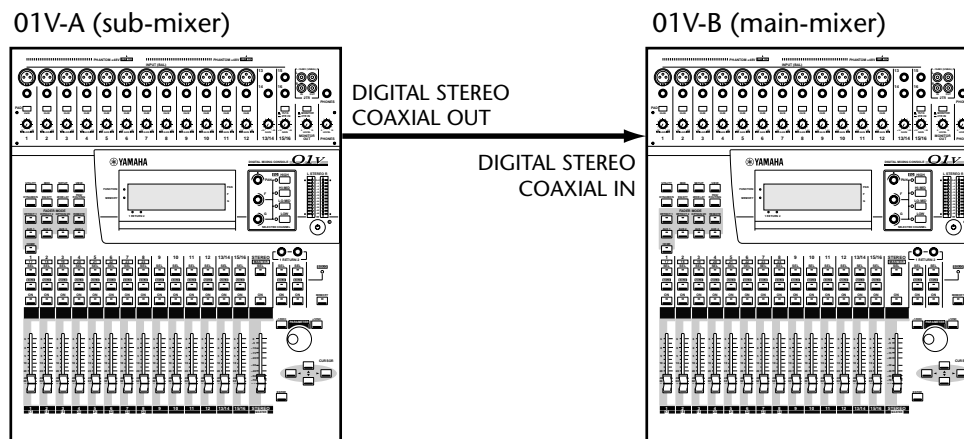

For cascade operation, 01V-B Coaxial input should not be flipped and Stereo Cascade should be turned on. See “Digital Stereo In” on page 213 for more information.

## MIDI Local Control

Using the MIDI Local Control function, 01V-A can be controlled using the controls on 01V-B. When Local Control on 01V-B is turned off, its faders, buttons, and display pages all control 01V-A instead of its own functions. In addition, the meters on 01V-B display 01V-A signal levels. See “Local Control” on page 234 for more information.

## Link Port

For simultaneous solo operation, display page and fader mode selection, two or more 01Vs can be linked together using the TO HOST or MIDI ports. See “Linking 01Vs” on page 239.

## Cascading Aux Sends

Aux sends can be cascaded as follows. Assign, say, aux send 1 on 01V-A (submixer) to a MONI OUT and connect it to, say, input 13 on 01V-B (main-mixer). Then, feed channel 13 on 01V-B through to aux send 1 pre-fader. 01V-B aux send 1 output now contains the aux send 1 signals of both 01Vs. Aux sends 2, 3, and 4 can be cascaded in a similar manner using inputs 14, 15, and 16 on 01V-B.



### Cascade Delay

Since it takes 01V-A several hundred microseconds to process its digital audio data, the input signals of 01V-B need to be delayed slightly to bring them into phase with the signals from 01V-A. The following illustration shows why phase correction is necessary.

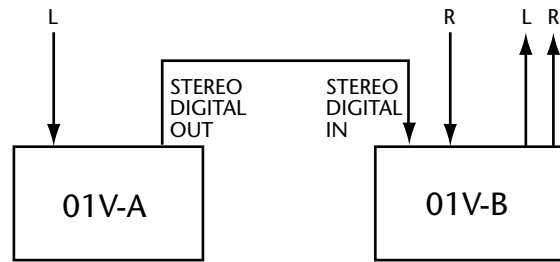

Since signal L has been processed by both 01V-A and 01V-B, it's out of phase with signal R. To bring the signals back in phase, input signal R is delayed by 14 samples on 01V-B.

This kind of phase correction is not unique to the 01V. All digital audio equipment takes a few hundred microseconds to process digital audio data. Use the Delay function (“Delaying Channel Signals” on page 45) on 01V-B to delay all input channels by 14 samples.

### Cascading Two or More 01Vs

In this example, the channel delay should be set to 14 samples on 01V-C, 28 samples on 01V-B.

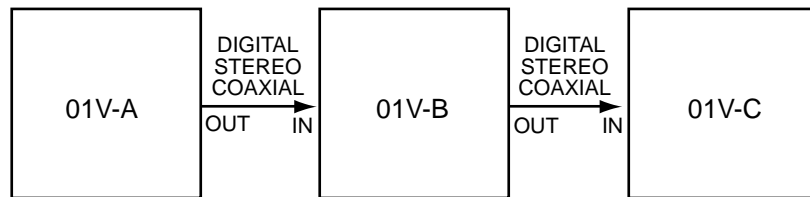

## About Option I/O Cards

The 01V features a single slot for an optional Option I/O card, providing eight digital inputs (input channels 17 through 24) and eight assignable digital outputs. Option I/O allows a direct digital connection to digital multitrack recorders, with cards for the following formats: ADAT, Tascam, and AES/EBU. Various Option I/O cards with analog inputs and outputs are also available. See the Yamaha PA Web site for news of other 01V Option I/O cards. 01V Option I/O cards are not interchangeable with the YGDAI cards used by the Yamaha 02R and 03D Digital Recording Consoles.

<<http://www.yamaha.co.jp/product/proaudio/homeenglish/>>

### **MY8-AT ADAT**

The MY8-AT card has two Alesis ADAT MultiChannel Optical Digital Interface connectors and is used to connect 8-track digital multitrack recorders such as the Alesis ADAT, Alesis ADAT-XT, or Fostex D-90 Hard Disk Recorder.

### **MY8-TD Tascam**

The MY8-TD card has a Tascam Digital Audio Interface (TDIF-1) 25-pin D-sub connector and is used to connect 8-track digital multitrack recorders such as the Tascam DA-88 or DA-38. MY8-TD cards feature a device selector switch that should be set according to the type of recorder connected. EXT: 88 for use with a Tascam DA-88. INT: 38 for use with a Tascam DA-38 or other recorder.

### **MY8-AE AES/EBU**

The MY8-AE card has a 25-pin D-sub connector and is used to connect digital audio equipment with AES/EBU format digital inputs and outputs.

### **MY4-DA Analog Output**

The MY4-DA card features four analog XLR outputs. With this card you could, for example, assign the four bus outs to the Omni outputs and the four aux sends to the MY4-DA analog outputs for a total of eight analog outputs.

### **MY8-AD 8 Analog Input**

The MY8-AD card features eight analog phone jack inputs, providing eight analog inputs to input channels 17 through 24.

### **MY4-AD 4 Analog Input**

The MY4-AD card features four analog XLR inputs, providing four analog inputs to input channels 17 through 20.

## Card Specifications

Card	Description	Inputs	Outputs	Connector
MY8-AT	ADAT Digital I/O	8 (CH17–24)	8 (bus, aux, stereo, ch direct)	Optical x2
MY8-TD	Tascam TDIF-1 Digital I/O	8 (CH17–24)		25-pin D-sub x1
MY8-AE* <sup>1</sup>	AES/EBU Digital I/O	8 (CH17–24)		25-pin D-sub x1
MY4-DA	Analog output	—	4 (bus, aux, stereo, ch direct)	XLR-3-32 type (balanced) x4
MY8-AD	Analog input	8 (CH17–24)	—	Phone jack x8
MY4-AD	Analog input	4 (CH17–20)	—	XLR-3-31 type (balanced) x4

\*1. Cable not included.

The eight Option I/O digital inputs feed input channels 17 through 24. See “Input Channels 17–24” on page 40 for more information. The inputs to channels 1 through 8 can be swapped with those of input channels 17 through 24 either individually or altogether. This allows signals from the Option I/O digital inputs to make use of the 4-band EQ, dynamics processors, and other functions of full-feature input channels 1 through 8. See “Swapping Inputs 1–8 & 17–24” on page 51 for more information. Option I/O digital audio signals containing emphasis are automatically deemphasized.

The eight Option I/O digital outputs can be assigned to bus outs 1 through 4, aux sends 1 through 4, the left or right channels of the stereo output, or the post-fader direct outputs of input channels 1 through 16. See “Assigning Option I/O Digital Outputs” on page 219 for more information.

## Installing Option I/O Cards

*Warning: Turn off the 01V before installing an Option I/O card. Failure to do so is an electrical shock hazard and may cause serious damage.*

1. Turn off the 01V.
2. Undo the two fixing screws and remove the slot cover, as shown below.

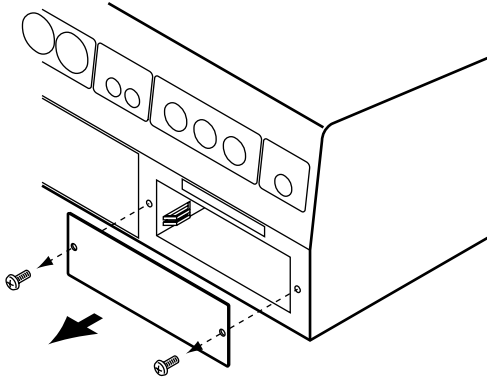

Keep the cover in a safe place for future use.

3. Insert the card into the slot as shown below. Push it in all the way so that the card's connector mates correctly with the internal 01V connector.

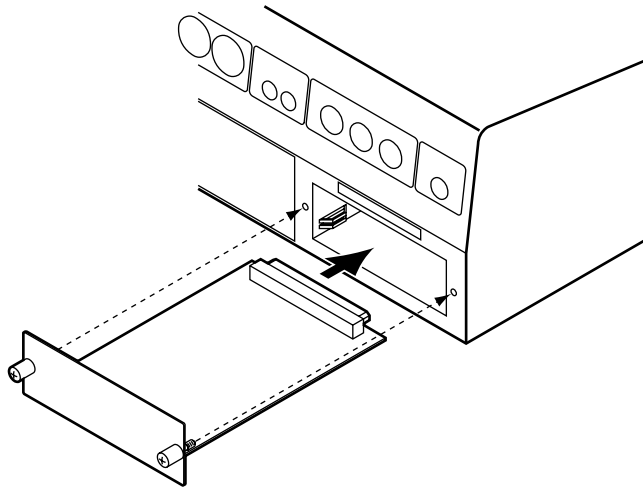

4. Secure the card using the two fixing screws. Do not leave the screws loose, as the card will not be grounded correctly.
5. Turn on the 01V.

The 01V checks to see what type of Option I/O card is installed when it's turned on. If installation is successful, the type of card installed is displayed on OPTION page 1, as shown below.

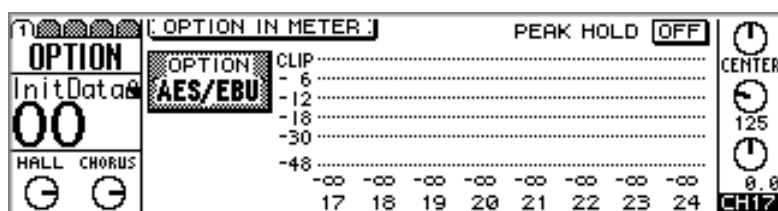

## Assigning Option I/O Digital Outputs

The eight Option I/O digital outputs can be assigned to bus outs 1 through 4, aux sends 1 through 4, the left or right channels of the stereo output, or the post-fader direct outputs of input channels 1 through 16. Although the 01V is a four-bus mixer, assigning the four bus outs and four aux sends to digital outputs allows eight-track simultaneous recording.

1. Use the [OPTION I/O] button to locate OPTION page 4, as shown below.

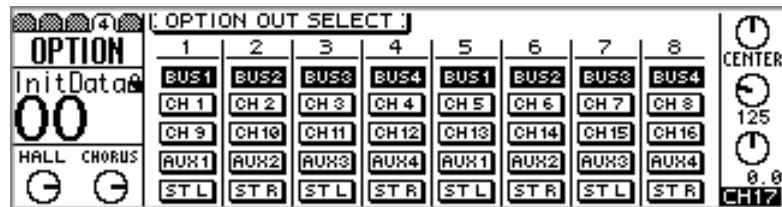

2. Use the cursor buttons to select the switches, and the [ENTER] button, PARAMETER wheel, or [-1/DEC] and [+1/INC] buttons to set them.

Switches appear highlighted when selected as the output source.

Option I/O digital outputs are automatically assigned to post-fader direct outputs of input channels 1 through 12 when the corresponding D switch on PAN/ROUT page 1 is turned on. Likewise, when a direct output is selected as the source for an Option I/O output on this page, the corresponding D switch is turned on on the PAN/ROUT page. See “Routing Input Channels” on page 49 for more information.

# Option I/O Block Diagram

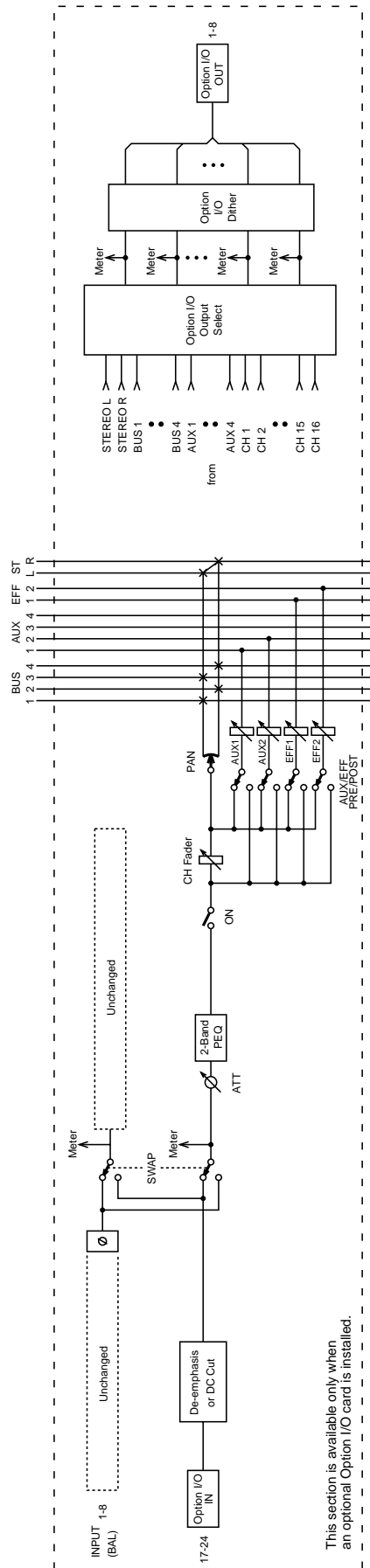

This section is available only when an optional Option I/O card is installed.

---

**MIDI**

---

# 17

**In this chapter...**

MIDI & the 01V .....	222
MIDI Ports .....	222
MIDI Receive Indicators .....	224
MIDI Setup .....	224
Program Change Scene Recall .....	227
Control Change Parameter Control .....	229
System Exclusive Parameter Control .....	231
Bulk Dump .....	232
Local Control .....	234
MIDI Machine Control .....	236
User Defined MIDI Controllers .....	238
Linking 01Vs .....	239

## MIDI & the 01V

The 01V can be used with MIDI in the following ways.

- Program Change messages for mix scene recall—“Program Change Scene Recall” on page 227.
- Control Change messages for real-time parameter control—“Control Change Parameter Control” on page 229.
- System Exclusive messages for parameter control—“System Exclusive Parameter Control” on page 231.
- System Exclusive Bulk Dump for data backup and transfer between 01Vs—“Bulk Dump” on page 232.
- MMC (MIDI Machine Control) for remote recorder control—“MIDI Machine Control” on page 236.
- MIDI Link for simultaneous operation—“Linking 01Vs” on page 239.
- MIDI Local Control for remote 01V operation—“Local Control” on page 234.
- User defined MIDI controllers for remote operation—“User Defined MIDI Controllers” on page 238.
- MIDI Note On for Freeze effect playback and Note On velocity for the DYNA.FILTER, DYNA.FLANGE, and DYNA.PHASER effects—“Effects Parameters” on page 138.

## MIDI Ports

The MIDI IN port receives MIDI messages, while the MIDI OUT port transmits them. The MIDI THRU port transmits all MIDI messages received at the MIDI IN port. In addition to regular MIDI ports, the 01V features a TO HOST port for connecting to a personal computer without a MIDI interface.

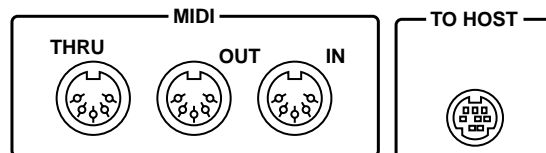

Apart from being a bidirectional connection that can transmit and receive MIDI data, the TO HOST port functions in the same way as the regular MIDI ports. Whether you use the regular MIDI ports or TO HOST port will depend on your particular system and application. The PORT parameter on MIDI page 1 is used to select the port for regular MIDI transmission. See “MIDI Setup” on page 224 for more information. The unused port automatically becomes the LINK PORT, which is used for simultaneous operation with another 01V.



## Using the TO HOST Port

In this system, the 01V is connected to a personal computer without a MIDI interface via the TO HOST port. The PORT parameter on MIDI page 1 is set to match the type of computer (PC-1, PC-2, or Mac). See “MIDI Setup” on page 224 for more information. 01V operations are recorded as MIDI messages by the MIDI sequencer software. During playback, the sequencer transmits the MIDI messages back to the 01V for automated mixing.

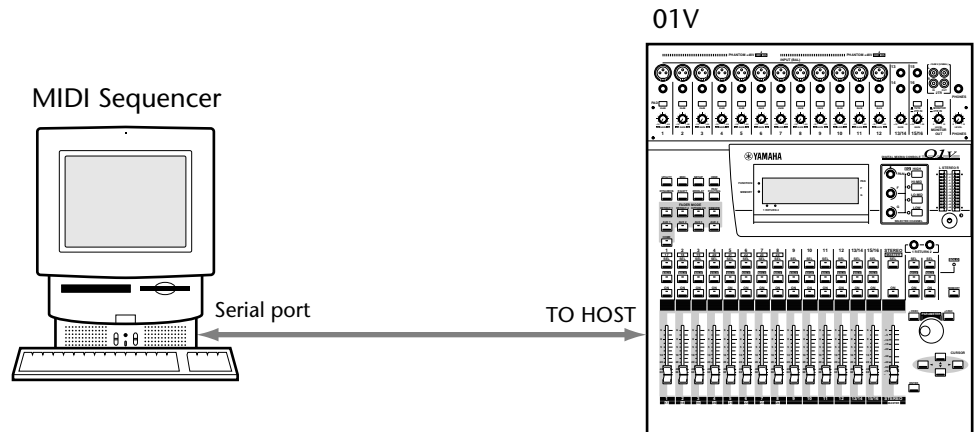

## Using the MIDI Ports

In this system, the 01V, MIDI keyboard, and MIDI sampler connect to the computer via a standard MIDI interface. Since the MIDI interface features only one MIDI IN port, which is connected to the MIDI OUT of the MIDI keyboard, the system must be repatched in order to record MIDI messages from the 01V. Alternatively, a MIDI interface with two or more MIDI INs could be used.

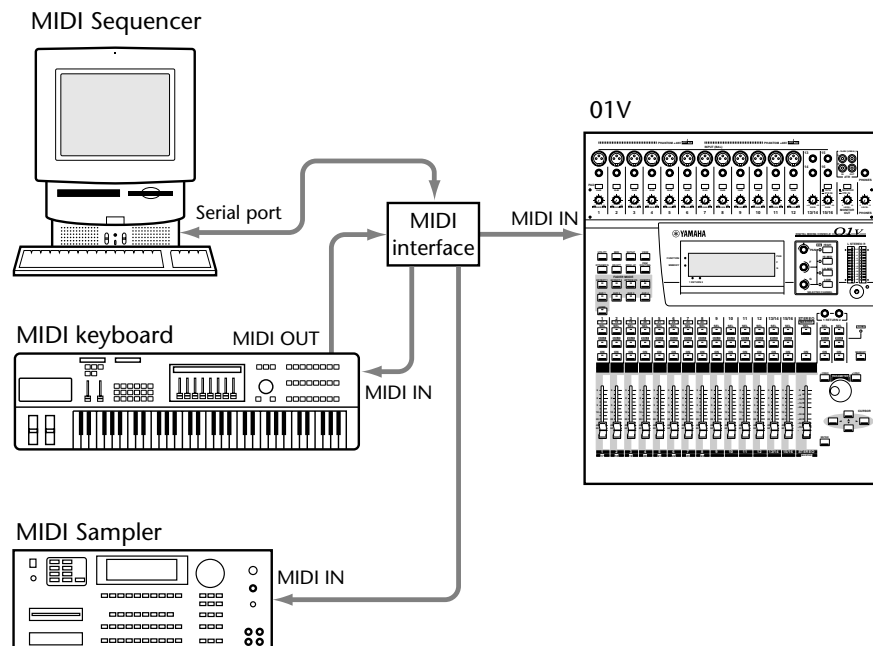

## Using the Link Port

In this system, two 01Vs are linked together for simultaneous operation. When, for example, mix scenes are recalled, Program Change messages are transmitted via the port assigned as the Link Port for simultaneous scene recall on both 01Vs. See “Cascading 01Vs” on page 214 for more information.

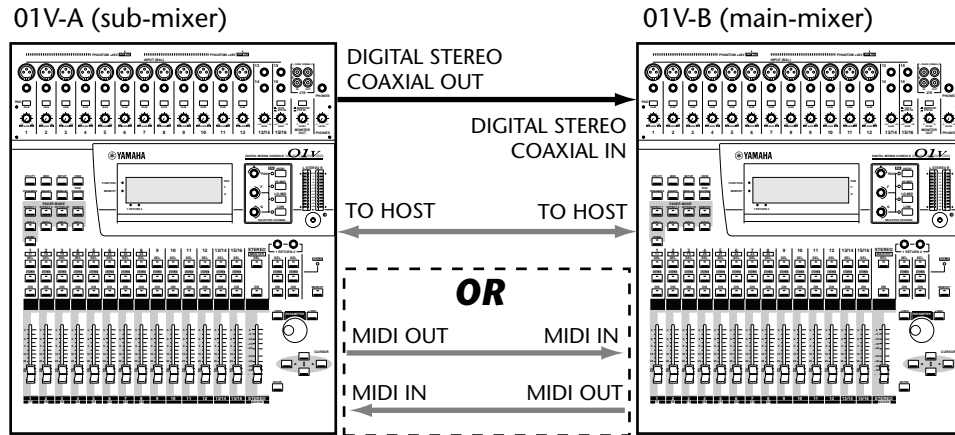

*Note: When the MIDI ports and TO HOST ports of two 01Vs are connected together, be sure to turn off the Program Change Tx and Rx switches. Otherwise, a MIDI loop will occur when mix scenes are recalled.*

## MIDI Receive Indicators

- MIDI** When MIDI data is received via the MIDI IN port, the MIDI receive indicator shown here appears.
- HOST** When data is received via the TO HOST port, the HOST receive indicator shown here appears.

## MIDI Setup

MIDI parameters such as transmit channel (Tx), receive channel (Rx), omni, and echo are set on MIDI page 1.

1. Use the [MIDI] button to locate MIDI page 1, as shown below.

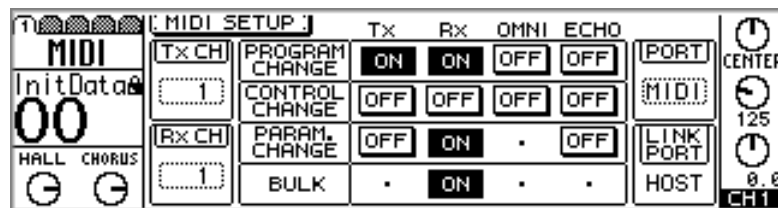

2. Use the cursor buttons to select the parameters, and the [ENTER] button, PARAMETER wheel, or [-1/DEC] and [+1/INC] buttons to set them.

**PORT/LINK PORT**—The PORT parameter determines whether the TO HOST or MIDI ports are used for regular MIDI transmission. The LINK PORT parameter, used when linking 01Vs (“Linking 01Vs” on page 239), is automatically set to the unused port. If, for example, PORT is set to MIDI, LINK PORT will be set to HOST, and vice

versa. When using the TO HOST port, PORT should be set to match the type of computer connected to the 01V, as follows.

Setting	Computer Platform	Port	Transmission Speed
<b>MIDI</b>	Standard MIDI	MIDI IN, OUT, THRU	31.25 kbps
<b>PC1</b>	NEC PC9800 Series	TO HOST	31.25 kbps
<b>PC2</b>	IBM PC compatible	TO HOST	38.4 kbps
<b>Mac</b>	Macintosh (clock: 1MHz)	TO HOST	31.25 kbps

**Tx CH**—This parameter determines which MIDI Channel the 01V uses to transmit MIDI messages, and can be set from 1 through 16. The device receiving MIDI messages from the 01V should be set to the same MIDI Channel. When the 01V transmits MIDI data in response to a request, that data is transmitted on the same MIDI Channel that the request was received on.

**Rx CH**—This parameter determines which MIDI Channel the 01V uses to receive MIDI messages, and can be set from 1 through 16. The device transmitting MIDI messages to the 01V should be set to the same MIDI Channel. When PROGRAM CHANGE OMNI or CONTROL CHANGE OMNI is turned on, program change and Control Change messages can be received regardless of this setting.

**PROGRAM CHANGE**—Program Change messages are used to recall mix scenes. See “Program Change Scene Recall” on page 227 for more information. The four ON/OFF switches in this group are as follows.

Tx determines whether the 01V transmits Program Change messages when a mix scene is recalled. Rx determines whether the 01V recalls mix scenes when Program Change messages are received. OMNI determines whether the 01V receives Program Change messages on all 16 MIDI Channels (ON) or just the Rx channel (OFF).

ECHO determines whether received Program Change messages are echoed through to the MIDI OUT port. When ECHO is on, the 01V receives Program Change messages and echoes them through to the MIDI OUT port regardless of the MIDI Channel settings.

**CONTROL CHANGE**—Control Change messages are used to control 01V parameters in real time. See “Control Change Parameter Control” on page 229 for more information. The four ON/OFF switches in this group are as follows.

Tx determines whether the 01V transmits Control Change messages when mix parameters are adjusted. Rx determines whether the 01V adjusts mix parameters when Control Change messages are received. OMNI determines whether the 01V receives Control Change messages on all 16 MIDI Channels (ON) or just the Rx channel (OFF).

ECHO determines whether received Control Change messages are echoed through to the MIDI OUT port. When ECHO is on, the 01V receives Control Change messages and echoes them through to the MIDI OUT port regardless of the MIDI Channel settings.

**PARAM. CHANGE**—Parameter Change System Exclusive messages are used to control 01V parameters in real time. See “System Exclusive Parameter Control” on page 231 for more information. The three ON/OFF switches in this group are as follows.

Tx determines whether the 01V transmits Parameter Change System Exclusive messages when mix parameters are adjusted. Rx determines whether or not the 01V adjusts mix parameters when Parameter Change System Exclusive messages are received. When Rx is turned on, the 01V transmits Parameter Change System Exclusive messages in response to requests even if Tx is turned off.

ECHO determines whether received Parameter Change System Exclusive messages are echoed through to the MIDI OUT port. When ECHO is on, the 01V receives Parameter Change System Exclusive messages and echoes them through to the MIDI OUT port regardless of the MIDI Channel settings.

**BULK**—This switch determines whether the 01V receives MIDI Bulk requests and MIDI Bulk Dump messages. When turned on, the 01V transmits Bulk Dump messages in response to Bulk Dump requests. Bulk Dump messages and Bulk Dump requests are never echoed. Bulk Dump messages can be transmitted from the 01V regardless of this setting. See “Bulk Dump” on page 232 for more information.

## Program Change Scene Recall

When a MIDI Program Change message is received, a mix scene is recalled in accordance with the scene memory to Program Change assignment table. Likewise, when a mix scene is recalled, the 01V transmits a Program Change message that can be used to recall a mix scene on another 01V or recorded to a MIDI sequencer for automated scene recall. See “Recalling Mix Scenes Using MIDI Program Change Messages” on page 188.

Initially, scene memories 1 through 99 are assigned sequentially to Program Changes 1 through 99 as listed in the “Scene Memory to Program Change Table” on page 273, although these assignments can be edited on MIDI page 2. These assignments are used for both transmission and reception, so if Program Change #10 is assigned to scene memory 20, the 01V recalls scene memory 20 when Program Change #10 is received, and transmits Program Change #10 when scene memory 20 is recalled.

In order for the 01V to receive and transmit MIDI Program Change messages, the Program Change Rx and Tx switches on MIDI page 1 must be turned on. See “MIDI Setup” on page 224 for more information.

1. Use the [MIDI] button to locate MIDI page 2, as shown below.

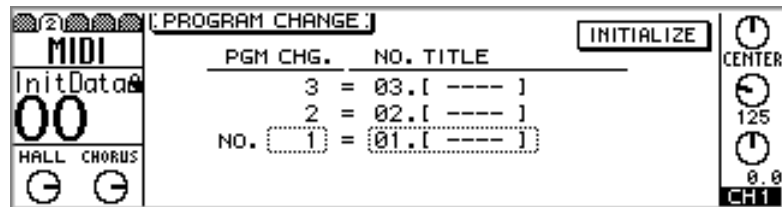

2. Use the cursor buttons to select the PGM CHG. column, and then use the PARAMETER wheel or [-1/DEC] and [+1/INC] buttons to select a Program Change.
3. Use the right cursor button to select the NO. TITLE column, and then use the PARAMETER wheel or [-1/DEC] and [+1/INC] buttons to select a scene memory.

A scene memory to Program Change assignment table is provided on page 273. To reset the assignments to their initial settings, use the cursor buttons to select the INITIALIZE switch, and then press the [ENTER] button. The dialog box shown here appears. Click OK to initialize.



The current scene memory to Program Change assignment table can be stored to an external MIDI device, such as a MIDI data filer, using MIDI Bulk Dump. See “Bulk Dump” on page 232 for more information.

If a scene memory is assigned to two or more Program Changes, the lowest Program Change is transmitted when that scene memory is recalled.

If a scene memory that is not assigned to a Program Change is recalled, a System Exclusive Parameter Change Scene Recall message is transmitted. See “System Exclusive Parameter Control” on page 231 for more information.

## Using Program Changes

In the following example, scene memory #10 is recalled on 01V-A and MIDI Program Change #10 is transmitted, hence scene memory #10 is also recalled on 01V-B. This assumes that the initial Program Change assignment table is being used. By editing the Program Change to scene memory assignments, Program Change #10 could be used to recall a different scene memory on 01V-B, or 01V-A could be set to transmit a different Program Change when scene memory #10 is recalled.

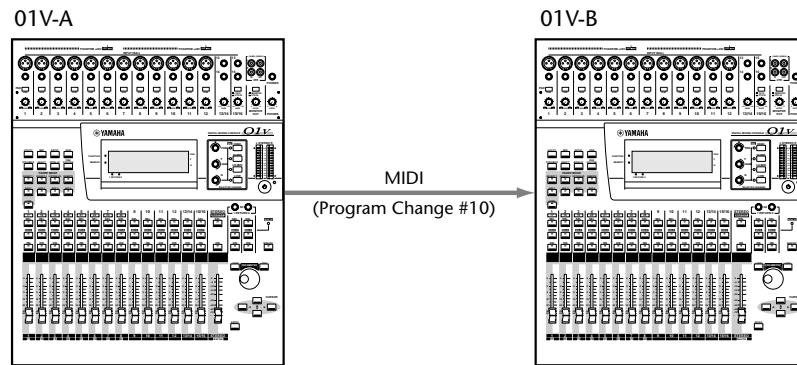

In the following example, program, or patch #5 is selected on the MIDI keyboard and MIDI Program Change #5 is transmitted, hence scene memory #5 is recalled on the 01V. This assumes that the initial Program Change assignment table is being used. By editing the Program Change to scene memory assignments, Program Change #5 could be used to recall a different scene memory on the 01V.

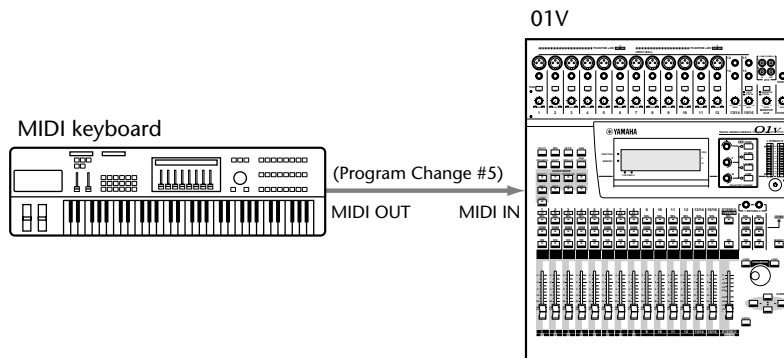

In the following example, Program Change #26 has been entered into a song on the MIDI sequencer. When the song is played, MIDI Program Change #26 is transmitted at the specified location and scene memory #26 is recalled automatically on the 01V. Since the 01V outputs Program Change messages when mix scenes are recalled, mix scene recalls can be recorded to the MIDI sequencer in real time.

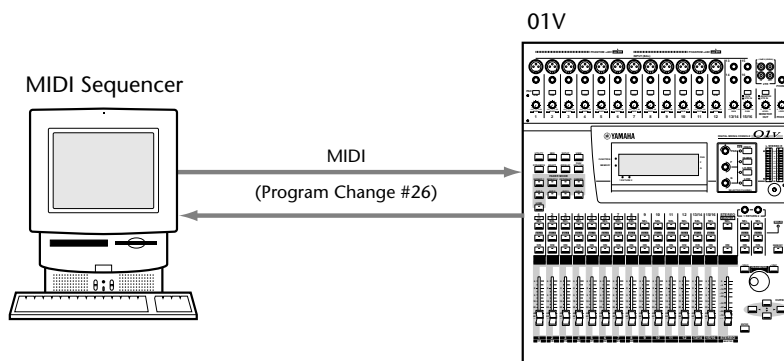

## Control Change Parameter Control

When a MIDI Control Change message is received, a mix parameter is adjusted in accordance with the parameter to Control Change assignment table. Likewise, when a mix parameter is adjusted, the 01V transmits a Control Change message that can be used to control another 01V or recorded to a MIDI sequencer for automated parameter control.

Up to 114 mix parameters can be assigned to Control Changes 0 through 95 and 102 through 119 (Control Changes 96 through 101 are not used). Initially, 01V parameters are assigned to Control Changes as listed in the “01V Parameter to Control Change Table” on page 274, although these assignments can be edited on MIDI page 3. These assignments are used for both transmission and reception, so if Control Change 10 is assigned to channel fader 10, the 01V adjusts channel fader 10 when Control Change #10 data is received, and transmits Control Change #10 when channel fader 10 is adjusted. Assignment tables for use with the Yamaha Programmable Mixer 01 and Yamaha 03D Digital Mixing Console are also provided.

In order for the 01V to receive and transmit MIDI Control Change messages, the Control Change Rx and Tx switches on MIDI page 1 must be turned on. See “MIDI Setup” on page 224 for more information.

1. Use the [MIDI] button to locate MIDI page 3, as shown below.

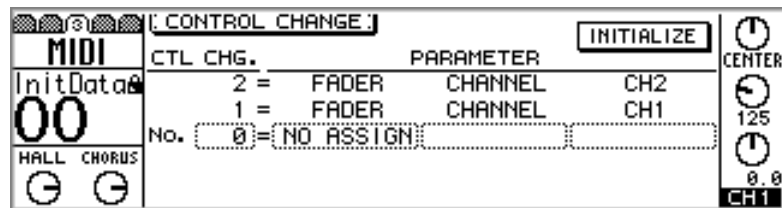

2. Use the cursor buttons to select the CTL CHG. column, and then use the PARAMETER wheel or [-1/DEC] and [+1/INC] buttons to select a Control Change.

Since Control Changes 0 and 32 are used in conjunction with Program Change and Bank Select messages, some MIDI sequencers may not record these Control Changes correctly. In this case, set Control Changes 0 and 32 to NO ASSIGN.

3. Use the right cursor button to select the PARAMETER columns and the PARAMETER wheel or [-1/DEC] and [+1/INC] buttons to select parameters.

A parameter to Control Change assignment table is provided on page 274. To reset the assignments to their initial settings, use the cursor buttons to select the INITIALIZE switch, and then press the [ENTER] button. The dialog box shown here appears. Choose DEFAULT to initialize.

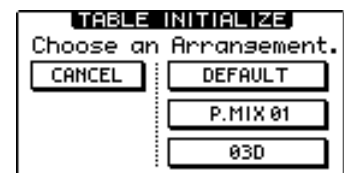

The P.MIX 01 and 03D switches are used to configure Control Changes for use with the Yamaha Programmable Mixer 01 or Yamaha 03D Digital Mixer. Parameter to Control Change assignment tables for these are provided on page 277.

The current parameter to Control Change assignment table can be stored to an external MIDI device, such as a MIDI data file, using MIDI Bulk Dump. See “Bulk Dump” on page 232 for more information.

When a Control Change message is received while MIDI page 3 is displayed, that Control Change is selected automatically, making it easy to determine which Control Change is being transmitted when, say, the slider of an external MIDI controller is operated.

### Using Control Changes

In the following example, 01V-A Master fader is operated and MIDI Control Change #27 is transmitted, hence the Master fader on 01V-B is also operated. This assumes that the initial Control Change assignment table is being used. By editing the Control Change to parameter assignments, Control Change #27 could be used to control a different parameter on 01V-B, or 01V-A could be set to transmit a different Control Change when its Master fader is operated.

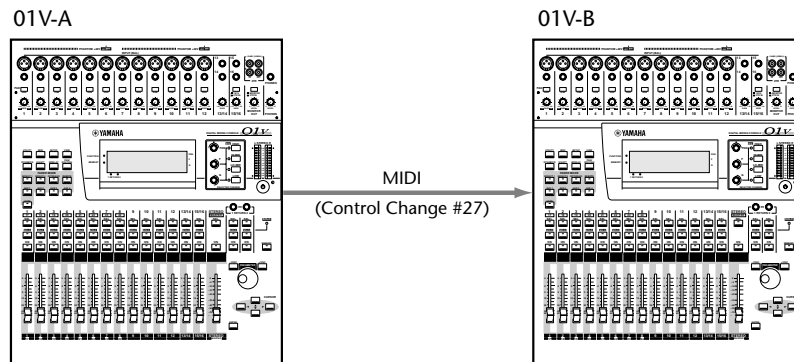

In the following example, an assignable MIDI controller on the MIDI keyboard is assigned Control Change #85. When this controller is adjusted, Control Change #85 is transmitted, hence the effects 1 send level for input channel 9 is adjusted on the 01V. This assumes that the initial Control Change assignment table is being used. By editing the Control Change to parameter assignments, MIDI controllers can be used to control various 01V parameters.

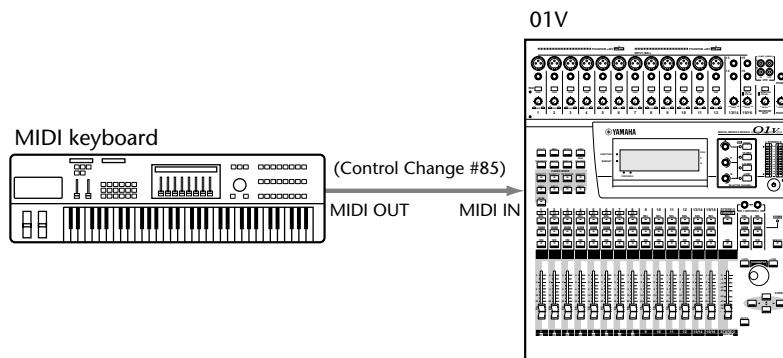



In the following example, input channel 5 fader movements are recorded in real time to a MIDI sequencer using Control Change #5. During playback, the sequencer transmits Control Change #5 messages back to the 01V and fader 5 moves accordingly. This technique can also be used with [ON] buttons, panpots, and effects, providing automated mixing.

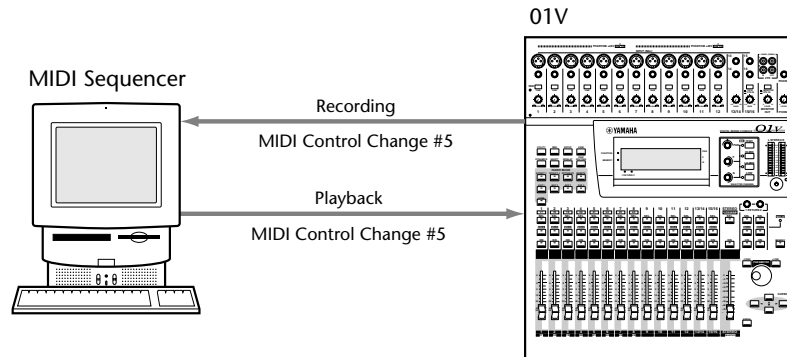

## System Exclusive Parameter Control

01V mix parameters can also be controlled in real time using MIDI System Exclusive messages. When a mix parameter is adjusted, the 01V transmits a System Exclusive Parameter Change message. The Transmit and Request functions on MIDI page 5 use System Exclusive messages to request parameter settings from other 01Vs.

When programs are recalled from the EQ, dynamics, or effects library, System Exclusive Parameter Change Library Recall messages are also transmitted. When channels are soloed, System Exclusive Parameter Change Key Remote messages are transmitted.

If a scene memory that is not assigned to a Program Change is recalled, a System Exclusive Parameter Change Scene Recall message is transmitted.

In order for the 01V to receive and transmit System Exclusive Parameter Change messages, the PARAM. CHANGE Rx and Tx switches on MIDI page 1 must be turned on. See “MIDI Setup” on page 224 for more information.

Data formats for System Exclusive Parameter Change messages are provided in “MIDI Data Format” on page 280.

## Bulk Dump

01V scene memories, library programs, and setup data can be transferred to another MIDI device using System Exclusive Bulk Dump. This can be used to back up important 01V data to a MIDI data file or controlling computer, or to exchange data between 01Vs.

The 01V can transmit MIDI System Exclusive Bulk Dump messages at anytime. In order for the 01V to respond to Bulk Dump requests from other MIDI devices, the BULK Rx switch on MIDI page 1 must be turned on. See “MIDI Setup” on page 224 for more information.

1. Use the [MIDI] button to locate MIDI page 4, as shown below.

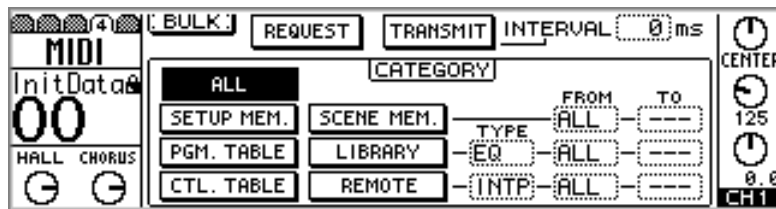

2. Use the cursor buttons to select a CATEGORY switch, and press the [ENTER] button to select it.  
The switch of the selected category appears highlighted.
3. For the SCENE MEM., LIBRARY, and REMOTE categories, use the cursor buttons, PARAMETER wheel, and [-1/DEC] and [+1/INC] buttons to set the TYPE, FROM, and TO parameters.

Data Type	Type	Range	Description
ALL	—	—	All the following data
SETUP MEM.	—	—	01V setup data (all current settings)
PGM. TABLE	—	—	MIDI page 2 settings (scene memory to Program Change assignment table)
CTL. TABLE	—	—	MIDI page 3 settings (parameter to Control Change assignment table)
SCENE MEM.	—	EDIT, 1–99	Scene memories (EDIT is the Edit Buffer)
LIBRARY	EQ	41–80	EQ library user programs
	DYNA	41–80	Dynamics library user programs
	EFF	43–99	Effects library user programs
REMOTE	INTP	Banks 1–4	REMOTE page 1 banks
	MMC	ALL (locate points 1–6)	REMOTE page 2 locate points
	UDEF	Banks 1–4	REMOTE page 3 banks

4. Use the cursor buttons to select the REQUEST or TRANSMIT switch, and then press the [ENTER] button.

When REQUEST is used, the 01V transmits a MIDI Bulk Dump request message. The receiving device then transmits the requested Bulk Dump data to the 01V. When TRANSMIT is used, the 01V transmits the selected data category via Bulk Dump.

**TRANSMIT INTERVAL**—This parameter specifies the interval between data blocks during Bulk Dump transmission. MIDI devices with a relatively small data buffer are easily overloaded when too much data is received at once. Setting an interval of, say, 300 milliseconds allows a slower device to process the received MIDI data correctly. An interval setting of 0 can be used when transferring Bulk Dump data between 01Vs.

## Using MIDI Bulk Dump

In the following example, the scene memories and user effects programs from 01V-A are transferred to 01V-B using MIDI Bulk Dump. The BULK Rx switch on MIDI page 1 of 01V-B must be turned on, otherwise the Bulk Dump data will be ignored. See “MIDI Setup” on page 224 for more information.

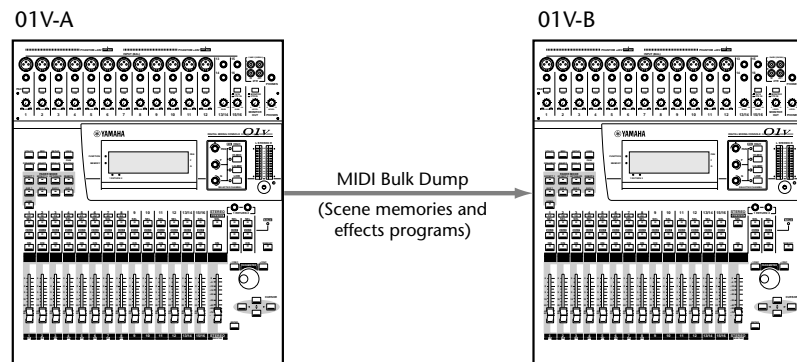

In the following example, all data from the 01V is transferred to a MIDI data file. The storage device could also be a computer running software with Bulk data management features. In order to transfer Bulk Dump data from the MIDI data file back to the 01V, the BULK Rx switch on MIDI page 1 must be turned on. See “MIDI Setup” on page 224 for more information.

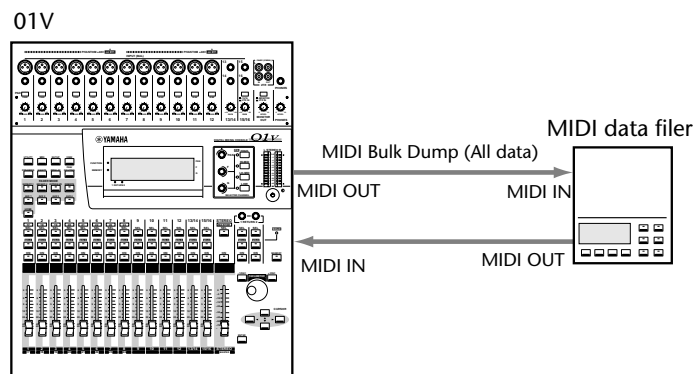

## Local Control

The MIDI Local Control function can be used to control a remote 01V. Normally, the 01V controls (faders, buttons, rotary controls, and display pages) set the 01V's internal parameters. When Local Control is turned off, the internal parameters remain the same when controls are operated but the System Exclusive Parameter Change messages that the 01V transmits can be used to control a remote 01V. Controllable parameters include all those that can be stored in mix scenes and the solo and monitor settings. When Local Control is turned off, the parameter values displayed on the local 01V are in fact those of the remote 01V. In addition, the meters on the local 01V display the signals levels of the remote 01V. This is useful when two 01Vs are cascaded together. See “Cascading 01Vs” on page 214 for more information.

1. Use the [MIDI] button to locate MIDI page 5, as shown below.

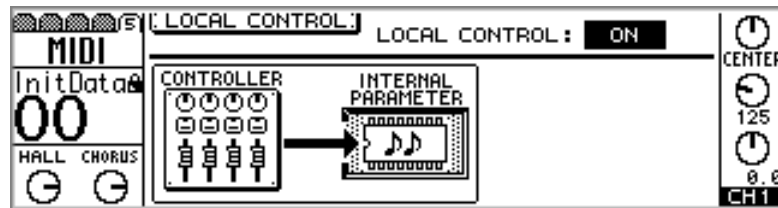

2. Use the cursor buttons to select the LOCAL CONTROL switch, and then press the [ENTER] button.

Local Control is turned off and MIDI page 5 appears, as shown below.

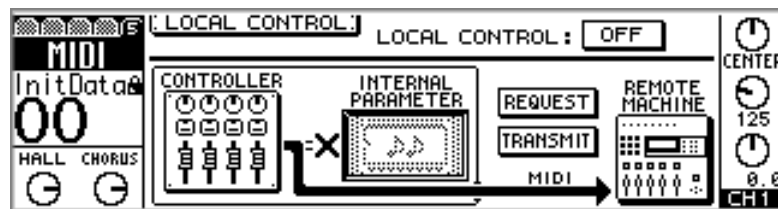

While Local Control is turned off, the function area of the display appears highlighted, as shown here, serving as a reminder that Local Control is off.



The TRANSMIT and REQUEST functions are used to match local and remote settings when 01Vs are first connected. The TRANSMIT function transmits the local 01V CONTROLLER settings to the remote 01V. The REQUEST function requests the parameter settings of the remote 01V and sets the local 01V CONTROLLER accordingly. The internal parameters of the local 01V are unaffected by either function.

For scene memories, the local 01V stores and recalls its own parameter settings regardless of the Local Control function.

Be aware that when Local Control is being used to control a remote 01V (i.e., Local Control is off on the local 01V), remote control may be disrupted temporarily due to wordclock abnormalities on the local 01V. Also, if parameters are adjusted directly on the remote 01V, the meters on the local 01V may not display levels correctly.

Local Control cannot be turned off while a mix-scene crossfade is in progress (Fade Time), and a warning message appears if you try to do so. Local Control can, however, be turned on while a mix-scene fade is in progress.

In the following example, 01V-A (remote) and 01V-B (local) are cascaded together for 48-channel digital mixing. Using the Local Control function, both 01Vs can be controlled using the faders, buttons, rotary controls, and display pages of 01V-B. Even the signal levels of 01V-A can be metered on 01V-B. To control 01V-B, the Local Control function on 01V-B is turned ON. To control 01V-A, the Local Control function on 01V-B is turned OFF. Both 01Vs should be set to the same PORT (MIDI or TO HOST), and the MIDI receive channel (Rx) on 01V-A should match the MIDI transmit channel (Tx) on 01V-B. See “MIDI Setup” on page 224 for more information.

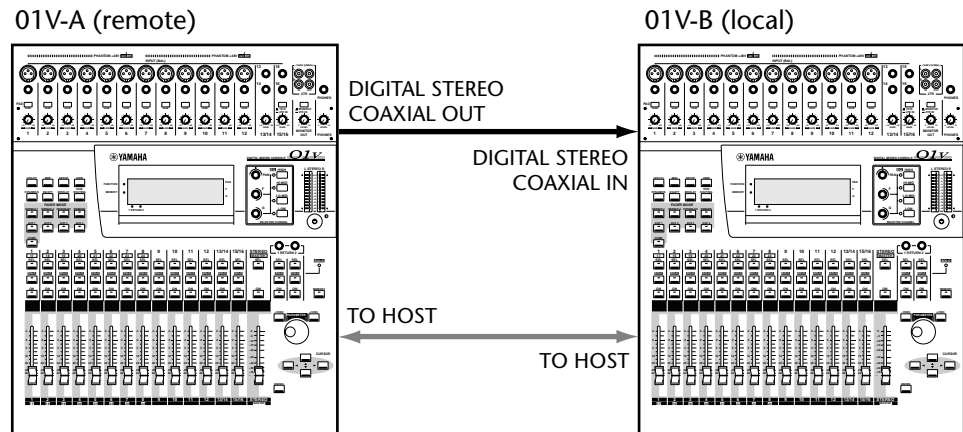

## MIDI Machine Control

Using MIDI Machine Control (MMC) commands, an MMC-compatible recorder can be controlled from the 01V. [ON] buttons 1 through 6 can be used to control transport functions, while [SEL] buttons 1 through 6 can be used to locate six definable locate points. MMC commands are transmitted via MIDI.

1. Use the [REMOTE] button to locate REMOTE page 2, as shown below.

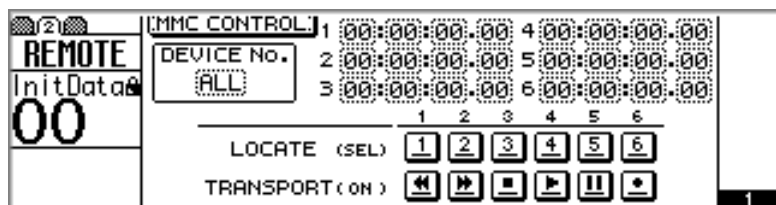

While this page is displayed, controls other than [ON] buttons 1 through 6 and [SEL] buttons 1 through 6 are disabled.

2. Use the cursor buttons to select the **DEVICE No. parameter**, and the **PARAMETER wheel** or [-1/DEC] and [+1/INC] buttons to select a device number.

The device number, which can be set from 1 through 127 or ALL, should be set to match that of the recorder you want to control. When set to ALL, all MMC-compatible recorders connected can be controlled together.

3. Use [ON] buttons 1 through 6 to transmit the following transport commands to a recorder.

On Button	Function	MMC Command Value
1	Rewind	05
2	Fast Forward	04
3	Stop	01
4	Play	02
5	Pause	09
6	Record	06

4. Use the cursor buttons and **PARAMETER wheel** or [-1/DEC] and [+1/INC] buttons to set the locate times in hours, minutes, seconds, and frames.
5. Use [SEL] buttons 1 through 6 to transmit the locate commands to the recorder.

Locate points can be stored using MIDI Bulk Dump. See “Bulk Dump” on page 232 for more information.

In the following example, an MMC-compatible hard disk recording system running on a personal computer is remotely controlled from an 01V using MMC commands. The device number on REMOTE page 2 of the 01V should match that of the hard disk recorder.

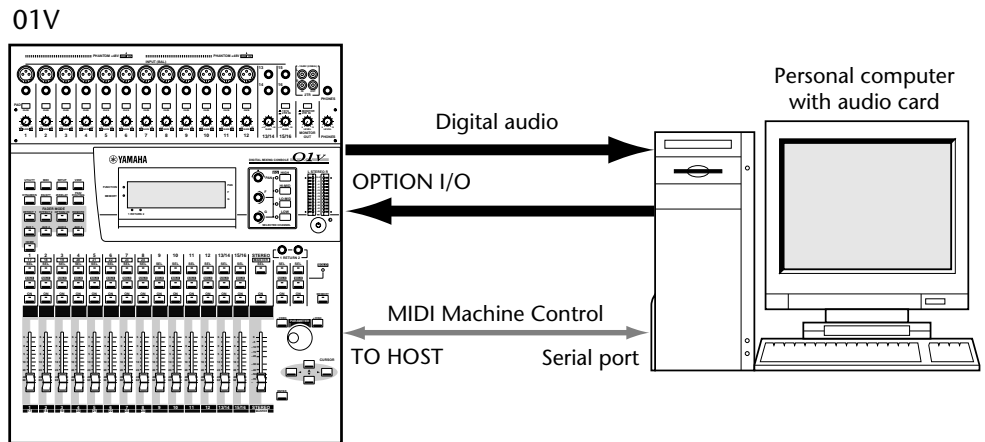

In the following example, an MMC-compatible digital multitrack recorder is remotely controlled from an 01V using MMC commands. The device number on REMOTE page 2 of the 01V should match that of the digital multitrack recorder.

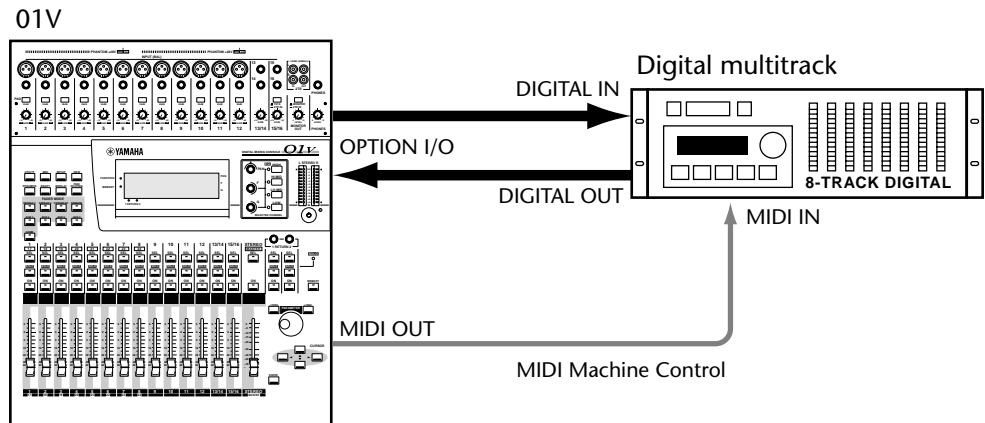

## User Defined MIDI Controllers

The [SOLO] buttons, [ON] buttons, and faders of channels 1 through 16 and Master can be used as MIDI controllers for remote MIDI device control. A MIDI data string up to 16 bytes long can be assigned to each control, and assignments are active only when REMOTE page 3 is displayed. Select another page and these controls perform their regular functions. Four assignment sets can be stored in banks 1 through 4.

1. Use the [REMOTE] button to locate REMOTE page 3, as shown below.

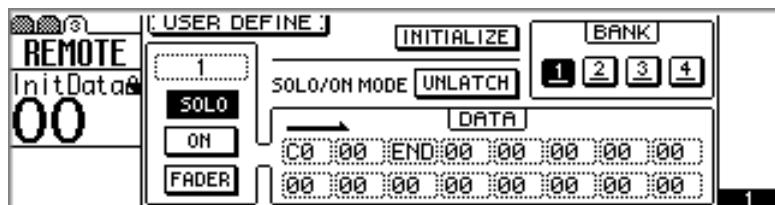

While this page is displayed, the [SOLO] and [ON] buttons and faders on channels 1 through 16 and Master transmit the assigned MIDI data when operated. Other controls are disabled.

2. Use the [SEL] buttons to select channels 1 through 16 or Master, and the cursor buttons and [ENTER] button to select the SOLO, ON, and FADER switches.

Controls can also be selected simply by operating them. For example, operating channel fader 5 automatically selects it. The switch of the selected control appears highlighted. The Master channel does not feature a [SOLO] button.

3. Use the cursor buttons to select the DATA parameters, and the PARAMETER wheel or [-1/DEC] and [+1/INC] buttons to set them.

The following hexadecimal DATA values can be set.

Hex: 00–FF

SW: [SOLO] and [ON] buttons (7F for ON, 00 for OFF)

FAD: Faders (00–7F)

END: Completes the command

4. Use the cursor buttons to select the BANK switches, and then press the [ENTER] button to activate the selected bank.

The switch of the active bank appears highlighted.

In UNLATCH mode, the [SOLO] and [ON] buttons function as momentary switches, and the specified data is transmitted when they're pressed and then released. SW is transmitted as 7F when buttons are pressed, and 00 when they're released.

In LATCH mode, the [SOLO] and [ON] buttons function as latching switches (i.e., they remain on when pressed), and the specified data is transmitted only when they're pressed. SW is transmitted as 7F when buttons are pressed, and 00 is transmitted when the buttons are pressed again.

When a Control Change message is received while REMOTE page 3 is displayed, its value appears in the DATA boxes, making it easy to determine which Control Change is being transmitted when, say, the slider of an external MIDI controller is operated.

Custom assignments are stored when other banks are selected, and banks can be stored using MIDI Bulk Dump. See “Bulk Dump” on page 232 for more information.



To reset a bank back to its initial assignments, make it the active bank, select the INITIALIZE switch, and then press the [ENTER] button. A confirmation dialog box appears. Select OK, and then press the [ENTER] button to confirm your action. The selected bank is reset to its initial assignments.

In the following example, REMOTE page 3 is displayed while the modulation controller on the MIDI keyboard is operated. The 01V detects Modulation Controller Control Change #1 and assigns it to the selected 01V fader. Then, when the fader is operated, the 01V transmits Control Change #1 messages back to the MIDI keyboard. The 01V must be set to receive MIDI Control Change messages. See “MIDI Setup” on page 224 for more information.

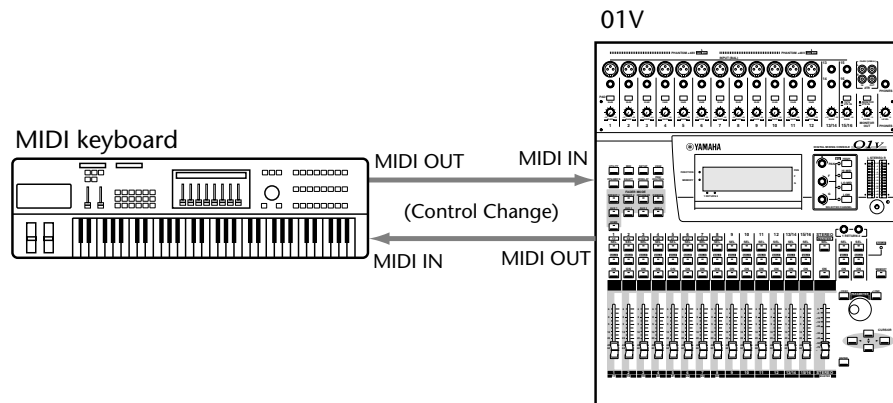

## Linking 01Vs

The TO HOST connection links the two or more 01Vs together for simultaneous operation, so when, for example, the fader mode is set to Aux 1 on 01V-B, the fader mode on 01V-A is also set to Aux 1, and vice versa. Other linked functions include

- Operations

Fader mode & Display page selection, Scene memory title edit, and Mix scene store (including title) and recall

- Parameters

Solo, Metering point (HOME page 5), and Meter Peak Hold on/off

The LINK PORT parameter on MIDI page 1 should be set to HOST. See “MIDI Setup” on page 224 for more information.

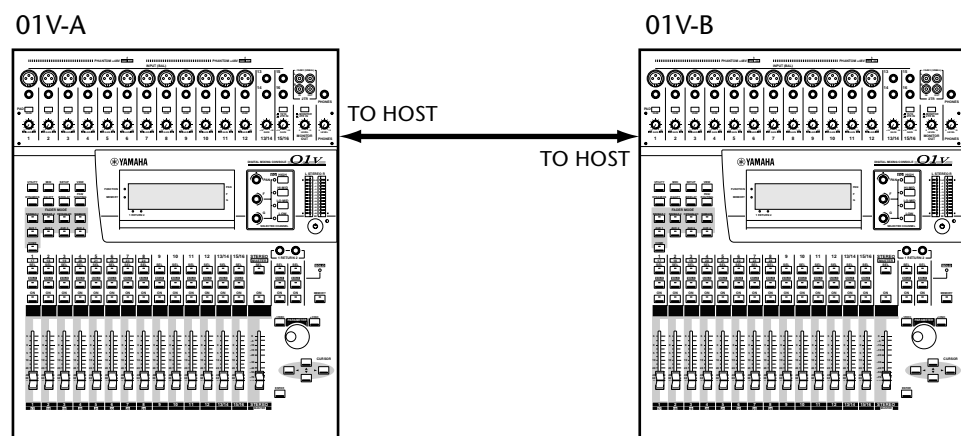

### Linking 01Vs using the MIDI Ports

If the TO HOST port is connected to a computer for MIDI purposes, simultaneous operation of two 01Vs is still possible using the MIDI ports, as shown below. The LINK PORT parameter on MIDI page 1 should be set to MIDI. See “MIDI Setup” on page 224 for more information.

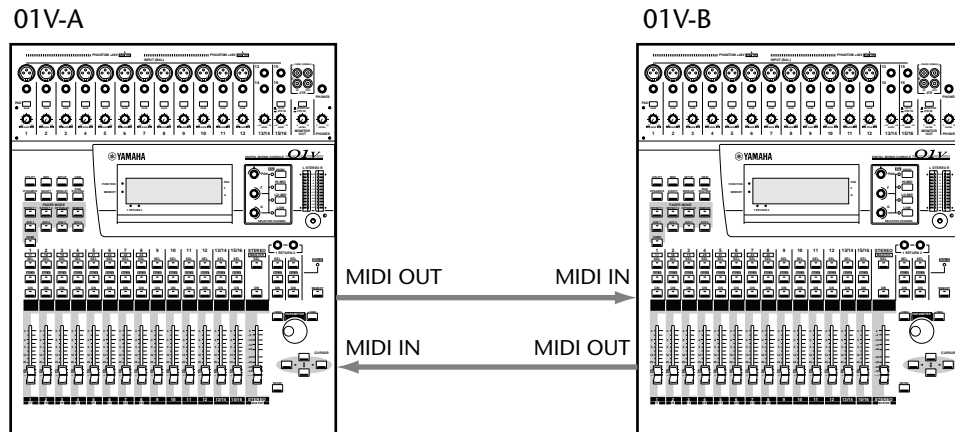

### Cascading Two or More 01Vs

Three or more 01Vs can be linked as shown below, although in this case, only settings made on 01VA are reflected to the other 01Vs. Adjustments made on 01V-B or 01V-C do not affect the other 01Vs. The LINK PORT parameters on MIDI page 1 should be set to MIDI. See “MIDI Setup” on page 224 for more information.

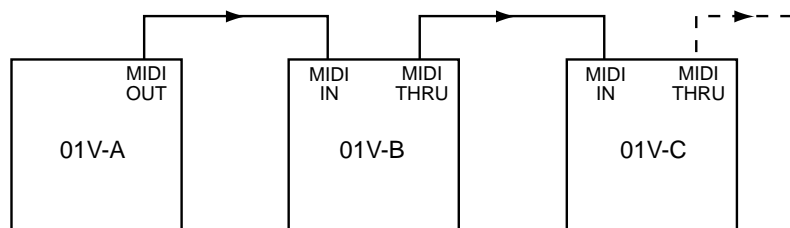

# System Examples

---

# 18

## In this chapter...

01V & ADAT-Interface Recorder .....	242
Two 01Vs & two ADAT-Interface Recorders .....	244
01V & Tascam-Interface Recorder .....	246
Two 01Vs & two Tascam-Interface Recorders .....	248
01V & Pro Tools (AES/EBU) .....	250

## 01V & ADAT-Interface Recorder

This example shows how the 01V can be used with an 8-track digital tape recorder, or 8-track hard disk recorder, featuring ADAT optical connections to create a 16-input, 8-track fully digital recording system, with the 16 mic/line inputs and eight digital tape returns providing up to 24 inputs during mixdown.

### System Components

- 01V Digital Mixing Console
- MY8-AT Option I/O card
- 8-track digital tape recorder, or 8-track hard disk recorder, such as Alesis ADAT, Alesis ADAT-XT, Alesis M20, Akai DR8, Akai DD8, Fostex D-90, or Fostex CX-8.
- Two ADAT optical cables

See “Installing Option I/O Cards” on page 218 for MY8-AT installation instructions.

### Wordclock Configuration

For digital audio transfer, digital audio devices must be wordclock synchronized (see “About Wordclocks” on page 206). In this example, the digital multitrack recorder is wordclock master and the 01V and DAT recorder are wordclock slaves. The 01V derives its wordclock from the Option I/O digital input. The DAT derives its wordclock from the Digital Stereo Coaxial Out of the 01V. The wordclock frequency, which is the same as the sampling rate, is set when the digital multitrack tape is formatted or first recorded.

For digital recording from the DAT recorder to the digital multitrack recorder, the DAT recorder must be configured as wordclock master and the 01V and digital multitrack recorder as wordclock slaves. In this case, the 01V would derive its wordclock from the Digital Stereo Coaxial In connection, and the digital multitrack recorder would derive its wordclock from the 01V’s Option I/O connection. The sampling rate will be the same as that used when the DAT tape was recorded. If a CD player is used instead of the DAT, the sampling rate will be fixed at 44.1 kHz, the industry-standard for music CDs.

### System Notes

- The digital IN and OUT connectors on the MY8-AT card are connected to the digital multitrack recorder using ADAT optical cables.
- On an Alesis ADAT 8-Track Digital Audio Recorder, use the DIGITAL IN button to select the optical digital input.
- Although the 01V is a four-bus mixer, a combination of bus outs, aux sends, and channel direct outputs can be assigned to the digital outputs for eight-track simultaneous recording. See “Assigning Option I/O Digital Outputs” on page 219 for more information.

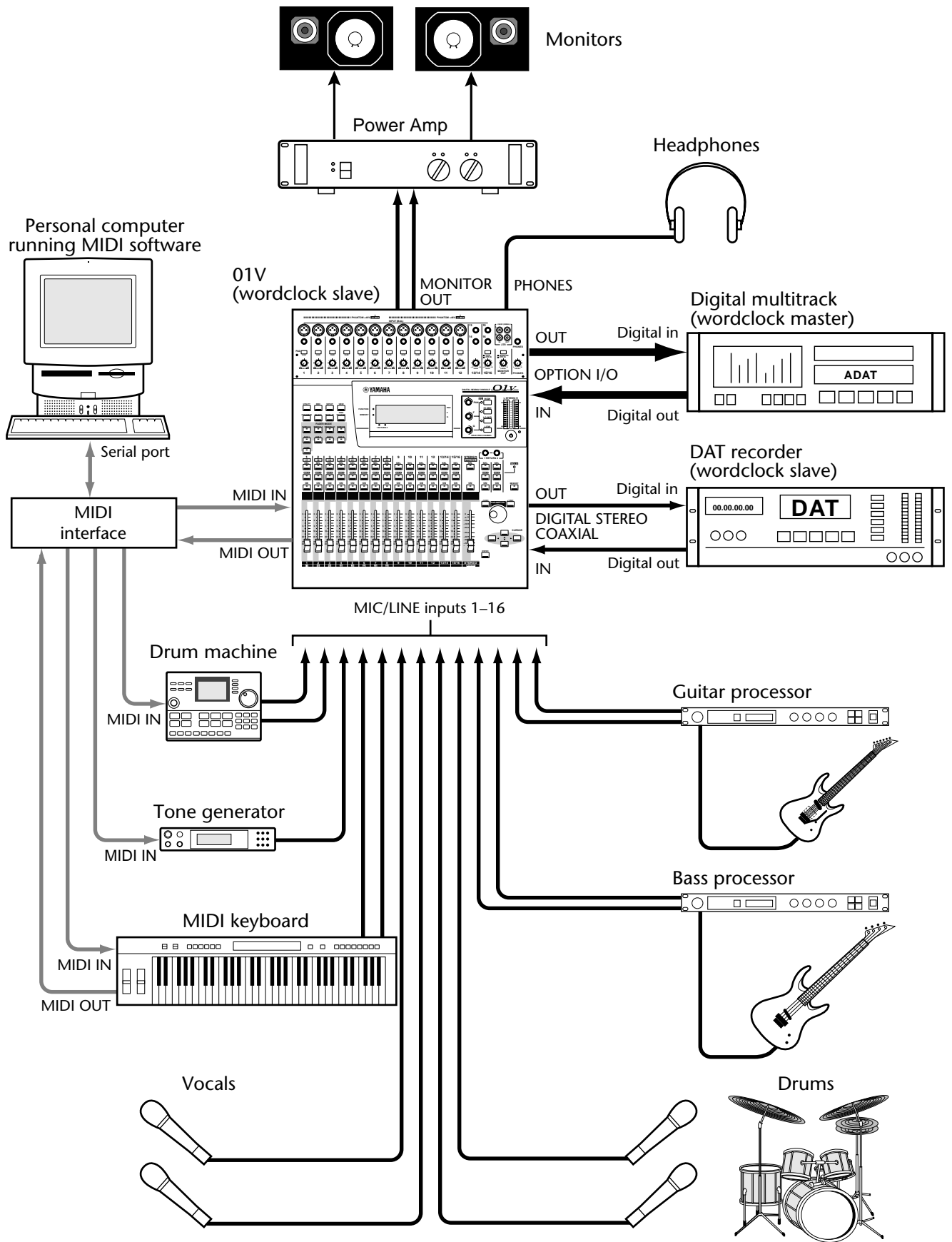

## Two 01Vs & two ADAT-Interface Recorders

This example shows how two 01Vs can be used with two 8-track digital tape recorders, or 8-track hard disk recorders, featuring ADAT optical connections to create a 32-input, 16-track fully digital recording system, with the 32 mic/line inputs and 16 digital tape returns providing up to 48 inputs during mixdown.

01V-A and 01V-B are cascaded together using the Stereo Digital In and Stereo Digital Out connections. 01V-B audio signals are combined into a stereo mix, which is then fed to 01V-A via the Digital Stereo Coaxial connections and mixed with the audio signals of 01V-A. The TO HOST connection links the two 01Vs together for simultaneous operation, so when, for example, the fader mode is set to Aux 1 on 01V-A, the fader mode on 01V-B is also set to Aux 1, and vice versa. See “Cascading 01Vs” on page 214 for more information.

### System Components

- Two 01V Digital Mixing Consoles
- Two MY8-AT Option I/O cards
- Two 8-track digital tape recorders, or 8-track hard disk recorders, such as Alesis ADAT, ADAT-XT, Alesis M20, Akai DR8, Akai DD8, Fostex D-90, or Fostex CX-8.
- Four ADAT optical cables
- ADAT sync cable

See “Installing Option I/O Cards” on page 218 for MY8-AT installation instructions.

### Wordclock Configuration

For digital audio transfer, digital audio devices must be wordclock synchronized (see “About Wordclocks” on page 206). In this example, digital multitrack recorder A is wordclock master, while digital multitrack recorder B, the 01Vs, and DAT recorder are wordclock slaves. Digital multitrack recorder B derives its wordclock from the sync connection with recorder A. The 01Vs derive their wordclocks from their Option I/O digital inputs, and the DAT, from the Digital Stereo Coaxial Out of the 01V. The wordclock frequency, which is the same as the sampling rate, is set when the digital multitrack tape is formatted or first recorded.

For digital recording from the DAT recorder to the digital multitrack recorders, the DAT recorder must be configured as wordclock master and the 01Vs and digital multitrack recorders as wordclock slaves. The sampling rate will be the same as that used when the DAT tape was recorded. If a CD player is used instead of the DAT, the sampling rate will be fixed at 44.1 kHz, the industry-standard for music CDs.

### System Notes

- The digital IN and OUT connectors on the MY8-AT cards are connected to the digital multitrack recorders using ADAT optical cables.
- On Alesis ADAT 8-Track Digital Audio Recorders, use the DIGITAL IN button to select the optical digital input.
- Although the 01V is a four-bus mixer, a combination of bus outs, aux sends, and channel direct outputs can be assigned to the digital outputs for eight-track simultaneous recording. See “Assigning Option I/O Digital Outputs” on page 219 for more information.

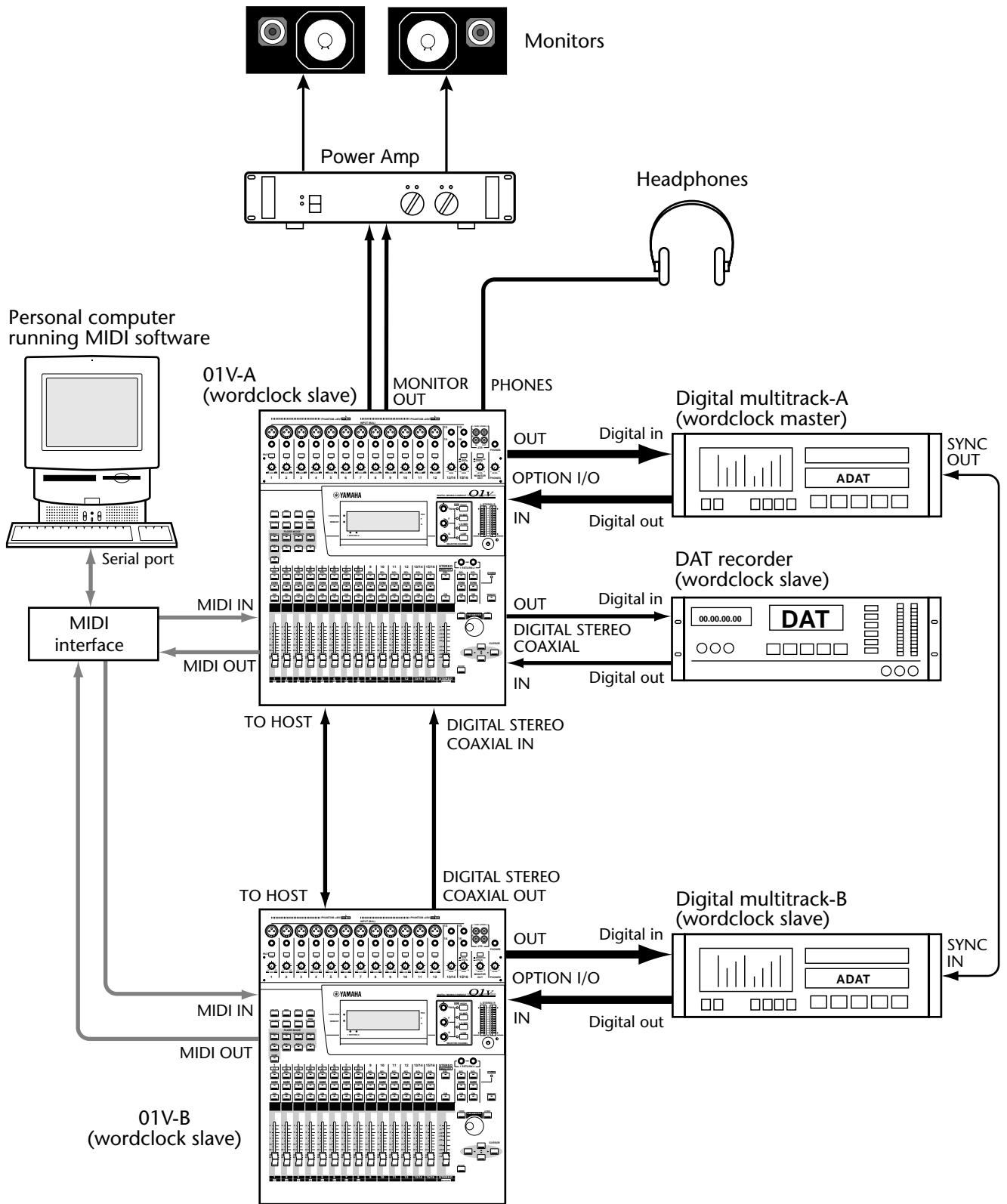

## 01V & Tascam-Interface Recorder

This example shows how the 01V can be used with an 8-track digital tape recorder, or 8-track hard disk recorder, featuring a Tascam Digital Audio Interface (TDIF-1) connection to create a 16-input, 8-track fully digital recording system, with the 16 mic/line inputs and eight digital tape returns providing up to 24 inputs during mixdown.

### System Components

- 01V Digital Mixing Console
- MY8-TD Option I/O card
- 8-track digital tape recorder, or 8-track hard disk recorder, such as the Tascam DA-38, Tascam DA-88, Tascam DA-98, or Akai DD8.
- Tascam PW-88D digital audio cable

See “Installing Option I/O Cards” on page 218 for MY8-TD installation instructions.

### Wordclock Configuration

For digital audio transfer, digital audio devices must be wordclock synchronized (see “About Wordclocks” on page 206). In this example, the digital multitrack recorder is wordclock master and the 01V and DAT recorder are wordclock slaves. The 01V derives its wordclock from the Option I/O digital input. The DAT derives its wordclock from the Digital Stereo Coaxial Out of the 01V. The wordclock frequency, which is the same as the sampling rate, is set when the digital multitrack tape is formatted or first recorded.

For digital recording from the DAT recorder to the digital multitrack recorder, the DAT recorder must be configured as wordclock master and the 01V and digital multitrack recorder as wordclock slaves. In this case, the 01V would derive its wordclock from the Digital Stereo Coaxial In connection. Since the digital multitrack recorder cannot derive a wordclock signal from its digital inputs, a BNC cable is used to supply a wordclock signal from the 01V. (Note that this connection is only necessary when the digital multitrack recorder is used as a wordclock slave.) The sampling rate will be the same as that used when the DAT tape was recorded. If a CD player is used instead of the DAT, the sampling rate will be fixed at 44.1 kHz, the industry-standard for music CDs.

### System Notes

- The TDIF-1 connector on the MY8-TD is connected to the digital multitrack recorder using a Tascam PW-88D digital audio cable.
- MY8-TD cards feature a device selector switch that should be set according to the type of recorder connected. “EXT: 88” for DA-88. “INT: 38” for DA-38 or other recorder.
- Although the 01V is a four-bus mixer, a combination of bus outs, aux sends, and channel direct outputs can be assigned to the digital outputs for eight-track simultaneous recording. See “Assigning Option I/O Digital Outputs” on page 219 for more information.
- The BNC wordclock connection from the 01V to the digital multitrack recorder is only necessary when the digital multitrack recorder is used as a wordclock slave.



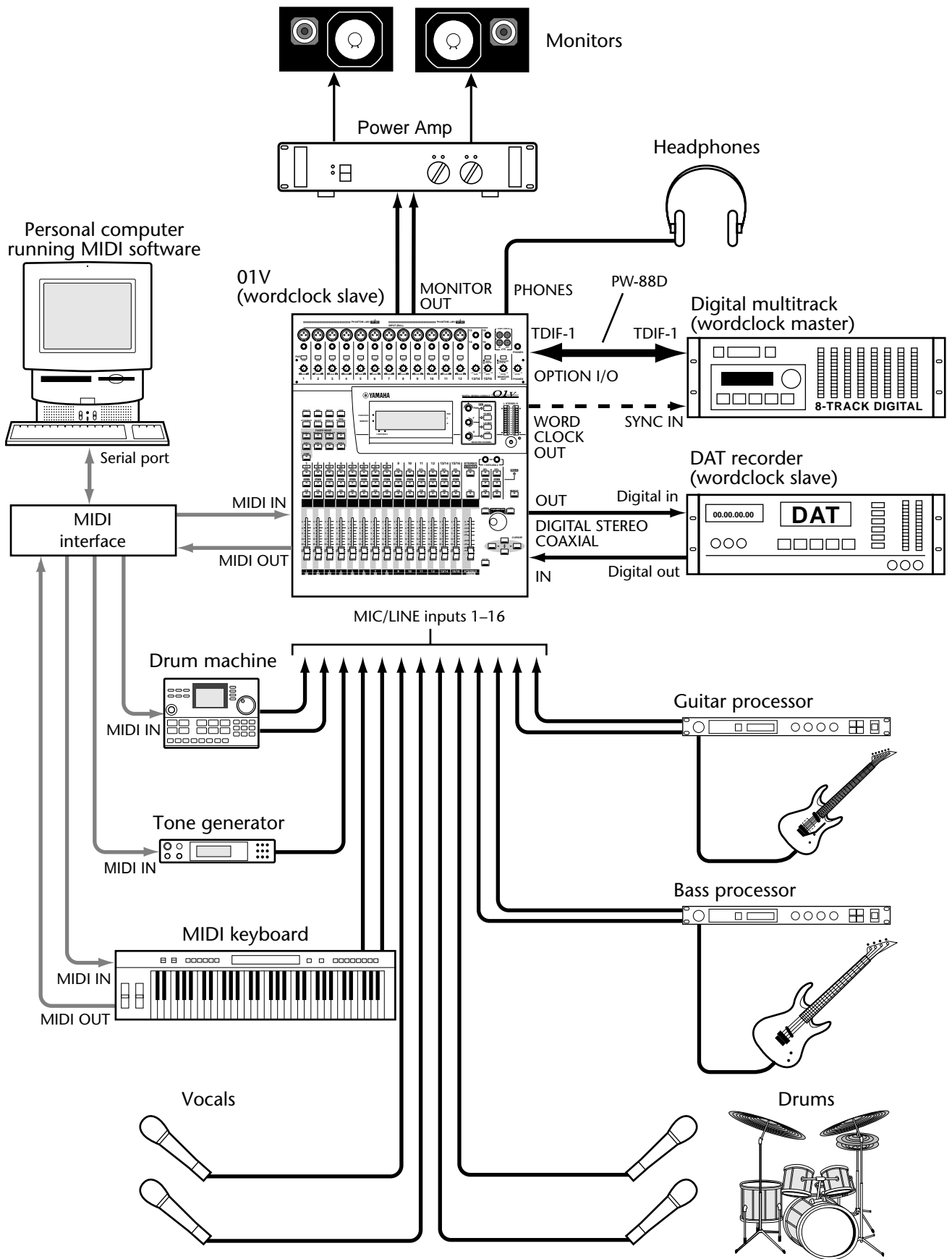

## Two 01Vs & two Tascam-Interface Recorders

This example shows how two 01Vs can be used with two 8-track digital tape recorders, or 8-track hard disk recorders, featuring Tascam Digital Audio Interface (TDIF-1) connections to create a 32-input, 16-track fully digital recording system, with the 32 mic/line inputs and 16 digital tape returns providing up to 48 inputs during mixdown.

01V-A and 01V-B are cascaded together using the Stereo Digital In and Stereo Digital Out connections. 01V-B audio signals are combined into a stereo mix, which is then fed to 01V-A via the Digital Stereo Coaxial connections and mixed with the audio signals of 01V-A. The TO HOST connection links the two 01Vs together for simultaneous operation, so when, for example, the fader mode is set to Aux 1 on 01V-A, the fader mode on 01V-B is also set to Aux 1, and vice versa. See “Cascading 01Vs” on page 214 for more information.

### System Components

- Two 01V Digital Mixing Consoles
- Two MY8-TD Option I/O cards
- Two 8-track digital tape recorders, or 8-track hard disk recorders, such as the Tascam DA-38 Tascam DA-88, Tascam DA-98, or Akai DD8.
- Two Tascam PW-88D digital audio cables
- Tascam PW-88S sync cable

See “Installing Option I/O Cards” on page 218 for MY8-TD installation instructions.

### Wordclock Configuration

For digital audio transfer, digital audio devices must be wordclock synchronized (see “About Wordclocks” on page 206). In this example, digital multitrack recorder A is wordclock master, while digital multitrack recorder B, the 01Vs, and DAT recorder are wordclock slaves. Digital multitrack recorder B derives its wordclock from the sync connection with recorder A. The 01Vs derive their wordclocks from their Option I/O digital inputs, and the DAT, from the Digital Stereo Coaxial Out of the 01V. The wordclock frequency, which is the same as the sampling rate, is set when the digital multitrack tape is formatted or first recorded.

For digital recording from the DAT recorder to the digital multitrack recorders, the DAT recorder must be configured as wordclock master and the 01Vs and digital multitrack recorders as wordclock slaves. The sampling rate will be the same as that used when the DAT tape was recorded. If a CD player is used instead of the DAT, the sampling rate will be fixed at 44.1 kHz, the industry-standard for music CDs.

### System Notes

- The TDIF-1 connectors on the MY8-TD cards are connected to the digital multitrack recorders using Tascam PW-88D digital audio cables.
- MY8-TD cards feature a device selector switch that should be set according to the type of recorder connected. “EXT: 88” for DA-88. “INT: 38” for DA-38 or other recorder.
- Although the 01V is a four-bus mixer, a combination of bus outs, aux sends, and channel direct outputs can be assigned to the digital outputs for eight-track simultaneous recording. See “Assigning Option I/O Digital Outputs” on page 219 for more information.

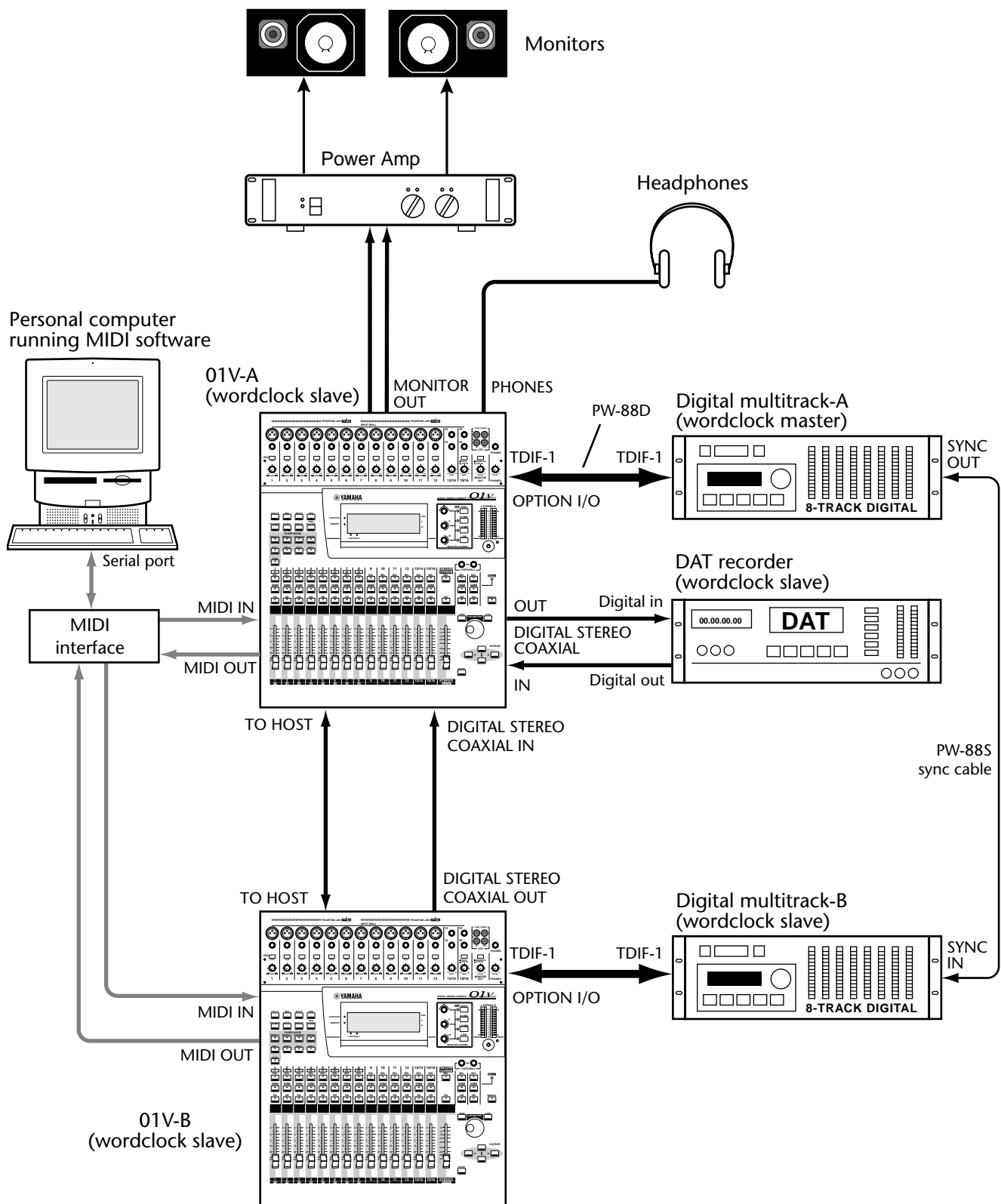

## 01V & Pro Tools (AES/EBU)

This example shows how the 01V can be used with a Pro Tools system to create a 16-input, 8-track fully digital recording system, with the 16 mic/line inputs and eight digital tape returns providing up to 24 inputs during mixdown.

A Digidesign 888 I/O Audio Interface connects the 01V to the Pro Tools system, with a special 50-pin Pro Tools cable between the computer card and 888. The 01V connects to the 888 via a 25-pin D-sub cable and XLR to 25-pin D-sub splitter box, which provides eight AES/EBU inputs (four XLRs) and eight AES/EBU outputs (four XLRs).

Pro Tools transport functions can be controlled remotely from the 01V using MIDI Machine Control (MMC) commands. See “MIDI Machine Control” on page 236 for more information.

### System Components

- 01V Digital Mixing Console
- MY8-AE Option I/O card
- Pro Tools system with Digidesign 888 I/O Audio Interface
- XLR to 25-pin D-sub splitter box (or 25-pin D-sub to XLR break-out cable)
- 25-pin D-sub cable, 50-pin Pro Tools cable

See “Installing Option I/O Cards” on page 218 for MY8-AE installation instructions.

### Wordclock Configuration

For digital audio transfer, digital audio devices must be wordclock synchronized (see “About Wordclocks” on page 206). In this example, Pro Tools is wordclock master and the 01V and DAT recorder are wordclock slaves. The 01V derives its wordclock from the Option I/O digital input. The DAT derives its wordclock from the Digital Stereo Coaxial Out of the 01V. The wordclock frequency, which is the same as the sampling rate, is set by Pro Tools.

For digital recording from the DAT recorder to Pro Tools, the DAT recorder must be configured as wordclock master and the 01V and Pro Tools as wordclock slaves. In this case, the 01V would derive its wordclock from the Digital Stereo Coaxial In connection, and Pro Tools would derive its wordclock from the 01V’s Option I/O connection. The sampling rate will be the same as that used when the DAT tape was recorded. If a CD player is used instead of the DAT, the sampling rate will be fixed at 44.1 kHz, the industry-standard for music CDs.

### System Notes

- The AES/EBU connector on the MY8-AE card is connected to the XLR to 25-pin D-sub splitter box using a 25-pin D-sub cable.
- The splitter box is connected to the 888 I/O Audio Interface using AES/EBU compatible XLR cables.
- The 888 I/O Audio Interface is connected to the Pro Tools audio card using a special 50-pin Pro Tools cable.
- The XLR to 25-pin D-sub splitter box is custom made and not available from Yamaha.
- A 25-pin D-sub to XLR break-out cable could be used instead of the splitter box.

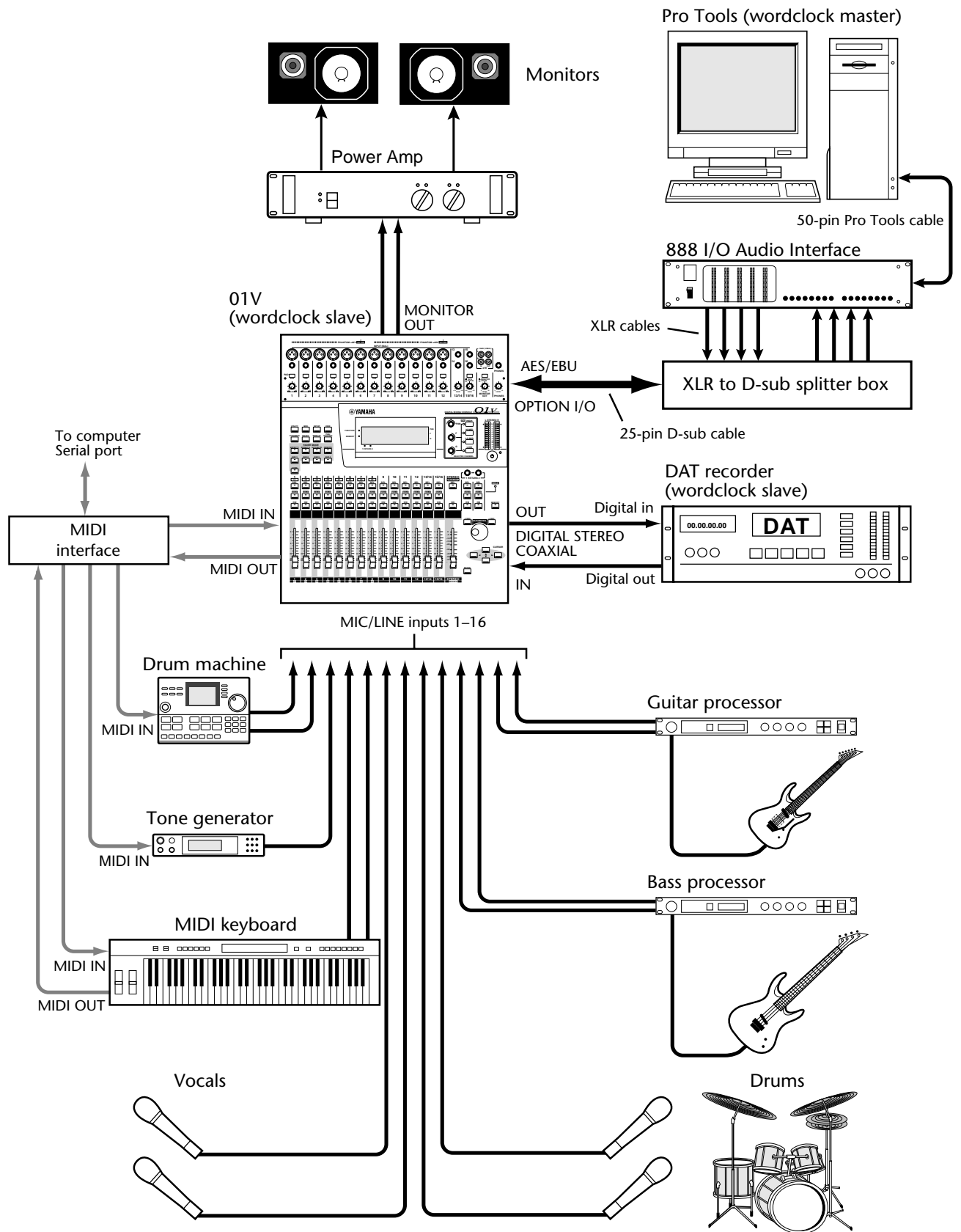

# Troubleshooting

Symptom	Advice
Cannot turn on the 01V.	Make sure that the power cord is connected to a suitable AC wall outlet. See “Connecting the Power Cord” on page 11 for more information.
	Make sure that the 01V POWER switch is set to the ON position. See “Turning On the 01V” on page 11 for more information.
	If you still cannot turn on the 01V, contact your Yamaha dealer.
The display is difficult to read.	Try adjusting the contrast. See “Display, Selected Channel Controls & Meters” on page 16 for more information.
Connected a condenser-type microphone but it doesn’t work.	Make sure that the +48 V phantom power is turned on for that input.
	If a phone plug is plugged into the same input channel, the XLR input is disabled. See “Input Channel Overview” on page 40 for more information.
The SELECTED CHANNEL PAN and EQ F and G controls adjust the wrong channel.	Use the [SEL] buttons to select channels. See “SEL Buttons” on page 32 for more information.
Input channel signal levels are too low or too high.	Make sure that the GAIN control and PAD switch are set correctly. See Gain and Pad on page 41.
	Use the HOME pages to check signal levels. See “Metering Signal Levels” on page 83 for more information.
Faders don’t function as expected.	Make sure that you have selected the right fader mode. See “Faders (plus Return Rotary Controls)” on page 35 for more information.
[SEL] buttons don’t function as expected.	Make sure that you have selected the correct fader mode. See “SEL Buttons” on page 32 for more information.
[SOLO] buttons don’t function as expected.	Make sure that you have selected the correct fader mode. See “Solo Buttons” on page 33 for more information.
[ON] buttons don’t function as expected.	Make sure that you have selected the correct fader mode. See “ON Buttons” on page 34 for more information.
Effects Return Rotary controls don’t function as expected	Make sure that you have selected the correct fader mode. See “Faders (plus Return Rotary Controls)” on page 35 for more information.
Cannot access input channels 17 through 24.	Input channels 17 through 24 are available only when an optional Option I/O card is installed. See “About Option I/O Cards” on page 216 for more information.
Cannot select the HI-MID and LO-MID EQ bands on input channels 17 through 24.	Input channels 17 through 24 feature 2-band EQ, so these bands cannot be selected.
Cannot send signals from input channels 17 through 24 to aux sends 3 and 4.	This is correct. Input channels 17 through 24 can only be sent to aux sends 1 and 2. See “About the Aux Sends” on page 94 for more information.
Input signals 1 through 8 appear on input channels 17 through 24.	Probably because the inputs have been swapped. See “Swapping Inputs 1–8 & 17–24” on page 51 for more information.
Input signals are present but the stereo output is dead.	Raise the STEREO fader and turn on the STEREO [ON] button. Make sure that the input channels are routed to the stereo output. See “Routing Input Channels” on page 49 for more information.

Symptom	Advice
Input signals are present but the monitor output and phones are dead.	Make sure that the MONITOR–2TR IN switch is set to MONITOR. See “Using Monitor” on page 78 for more information.
	Make sure a monitor SOURCE is selected on SETUP page 2. See “Monitor Setup” on page 78 for more information.
	Make sure that the MONITOR OUT LEVEL (or PHONES LEVEL) control is turned up. Also check the MONI TRIM parameter on SETUP page 2. See “Monitor Setup” on page 78 for more information.
Solo mode is selected but nothing can be heard.	Make sure that the MONITOR–2TR IN switch is set to MONITOR. See “Two-track Input (2TR IN)” on page 77 for more information.
	Make sure that the MONITOR OUT LEVEL (or PHONES LEVEL) control is turned up, and that the SOLO TRIM control on SETUP page 2 is turned up. See “Using Solo” on page 81 for more information.
Solo doesn’t function as expected and the [SOLO] button indicators light up instead of flashing.	Check whether or not the Solo function is enabled. See “Solo Setup” on page 80 for more information.
Channels seem to run out of headroom, especially when EQ boost is applied.	Use the Attenuator function on the EQ page to reduce the level. See “Attenuating Input Channel Signals” on page 43 for more information.
The Digital Stereo Coaxial In signal appears on input channels 13 and 14.	Probably because the Digital Stereo Coaxial In is flipped with inputs 13 and 14. See “Digital Stereo In” on page 213 for more information.
Cannot hear signals connected to inputs 13 and 14.	Probably because these inputs have been flipped with the Digital Stereo Coaxial In on PAN/ROUT page 4. See “Digital Stereo In” on page 213 for more information.
The 2TR IN signal appears on input channels 15 and 16.	Probably because the 15/16–2TR IN switch is set to 2TR IN. See “Two-track Input (2TR IN)” on page 77 for more information.
Cannot hear signals connected to inputs 15 and 16.	Probably because the 15/16–2TR IN switch is set to 2TR IN. See “Two-track Input (2TR IN)” on page 77 for more information.
Cannot select the bus out master faders.	Bus out master levels are set using the virtual faders on PAN/ROUT page 3. See “Setting Bus Out Master Levels” on page 109 for more information.
Recordings made via the Digital Stereo Coaxial Out or Option I/O sound grainy.	Make sure that the Dither function is set to match the wordlength of the digital recorder. See “Output Dither” on page 212 for more information.
Digital Stereo Coaxial In and Option I/O digital input signals sound noisy.	Make sure that all digital audio equipment is wordclock synchronized to a common wordclock source. See “About Wordclocks” on page 206 for more information.
Input channels are configured as a stereo pair but the signal appears to be mono.	Make sure that the odd channel is panned hard left and the right channel is panned hard right. See “Panning Input Channels” on page 47 for more information.
Configured a stereo pair but the signal sounds out of phase.	Make sure that the phase of both input channels in the stereo pair is set the same. Phase settings are not linked when channels are paired. See “Changing the Input Phase” on page 42 for more information.
Signals sound delayed.	Make sure that the Channel Delay function is set correctly. See “Delaying Channel Signals” on page 45 for more information.
Added faders to a fader group but grouping does not work.	Make sure that the fader group is enabled. See “Grouping Faders” on page 55 for more information.

Symptom	Advice
<b>Added channels to a mute group but group muting does not work.</b>	Make sure that the mute group is enabled. See "Grouping Mutes" on page 56 for more information.
<b>Cannot store an EQ program.</b>	EQ settings cannot be stored to preset programs 1 through 40. Try storing to user programs 41 through 80. See "Storing EQ Programs" on page 68 for more information. EQ settings of channel 17 through 24 can not be stored.
<b>Cannot recall EQ programs to input channels 17 through 24.</b>	EQ programs cannot be recalled to input channels 17 through 24.
<b>Cannot locate the aux send panpots.</b>	Aux send panpots are only available when aux sends are paired. See "Pairing Aux Sends" on page 101 for more information.
<b>The bus master level faders work in unison.</b>	Probably because the bus outs are paired. See "Pairing Bus Outs" on page 111 for more information.
<b>No output from the OMNI OUTs.</b>	Check the OMNI OUT source assignments. See "Assigning Omni Outs" on page 116 for more information.
<b>Cannot send channel signals to the effects processors.</b>	If the effects sends are configured post-fader, the regular channel fader must be raised in addition to the aux send fader. See "Using the Effects" on page 123 for more information.
<b>The effects send meters indicate that signals are being sent to the effects, but the processed sounds cannot be heard.</b>	Processed signals are returned via the effects returns. See "Returning Processed Signals" on page 124 for more information.
<b>Cannot store effects programs.</b>	Effects settings cannot be stored to preset programs 1 through 42. Try storing to user programs 43 through 99. See "Storing Effects Programs" on page 133 for more information.
<b>Cannot recall effects programs 19 and 42 to Effect 1.</b>	These effects programs use the HQ, PITCH and FREEZE type effects and can only be recalled to Effect 2. See "Preset Effects Programs" on page 121 for more information.
<b>Cannot feed effects return 1 to Effect 1, or effects return 2 to Effect 2.</b>	This is to prevent signal loops. See "Using the Effects" on page 123 for more information.
<b>Cannot store dynamics programs.</b>	Dynamics settings cannot be stored to preset programs 1 through 40. Try storing to user programs 41 through 80. See "Storing Dynamics Programs" on page 174 for more information.
<b>Cannot store to scene memory 00.</b>	Scene memory 00 is a read-only memory. See "Scene Memory 00" on page 185 for more information.
<b>Cannot store mix scenes.</b>	Is the selected scene memory protected? See "Protecting Scene Memories" on page 189 for more information.
<b>Cannot recall mix scenes.</b>	Only scene memories that contain data can be recalled.
<b>Help! I recalled a mix scene by mistake.</b>	Use the Undo function to return to the previous mix settings. See "Undoing Mix Scene Recalls" on page 189 for more information.
<b>The scene memory number keeps flashing.</b>	This is because a scene memory other than the one last recalled has been selected but not recalled. See "Scene Memory Display Area" on page 185 for more information.
<b>Recalling a mix scene doesn't update some channels.</b>	Perhaps these channels are safe channels? See "Recalling Scene Data Safely" on page 192 for more information.
<b>The specified fade time has no effect.</b>	Fade Time settings must be stored in mix scenes before they take effect. See "Setting a Fade Time" on page 191 for more information.



Symptom	Advice
<b>Fader movements are inconsistent.</b>	Try calibrating the faders. See “Calibrating the Faders” on page 204 for more information.
<b>DIGITAL IN Sync Error message appears.</b>	This warning message appears if digital signals from the Digital Stereo Coaxial In or Option I/O inputs are not wordclock synchronized with the 01V. Make sure that all digital equipment is wordclock synchronized to a common wordclock source. See “Setting the Wordclock” on page 209 for more information.
<b>UNLOCK appears in the Fs window of SETUP page 1.</b>	Make sure the external wordclock source is turned on and that the cable carrying the wordclock signal has not been disconnected. See “Setting the Wordclock” on page 209 for more information.
<b>Cannot transmit or receive MIDI messages.</b>	On MIDI page 1, check the following settings: PORT, Tx CH, Rx CH, and the Tx and Rx switches for Program Change, Control Change, etc. See “MIDI Setup” on page 224 for more information.
<b>MIDI Program Change messages don't recall mix scenes.</b>	Make sure that the 01V is configured to receive Program Change messages and that the MIDI Channels of the 01V and transmitting device match. See “MIDI Setup” on page 224 for more information.
	Perhaps the Program Change being transmitted is not assigned to an 01V scene memory? Check the mix scene to Program Change assignment table. See “Program Change Scene Recall” on page 227 for more information.
<b>MIDI Control Change messages don't control mix parameters.</b>	If the scene memory assigned to the received Program Change contains no data, it cannot be recalled.
	Make sure that the 01V is configured to receive Control Change messages and that the MIDI Channels of the 01V and transmitting device match. See “MIDI Setup” on page 224 for more information.
<b>Cannot receive MIDI Bulk Dump data.</b>	Perhaps the Control Change being transmitted is not assigned to an 01V parameter? Check the parameter to Control Change assignment table. See “Control Change Parameter Control” on page 229 for more information.
	Make sure that the BULK Rx switch on MIDI page 1 is turned on. See “MIDI Setup” on page 224 for more information.
<b>Controls have no effect on the 01V.</b>	Perhaps the Local Control function on MIDI page 5 is turned off? See “Local Control” on page 234 for more information.
<b>MMC commands have no effect.</b>	Make sure the device number matches that of the MMC-compatible recorder. See “MIDI Machine Control” on page 236 for more information.

# Appendix A: General

## 01V Level Diagram

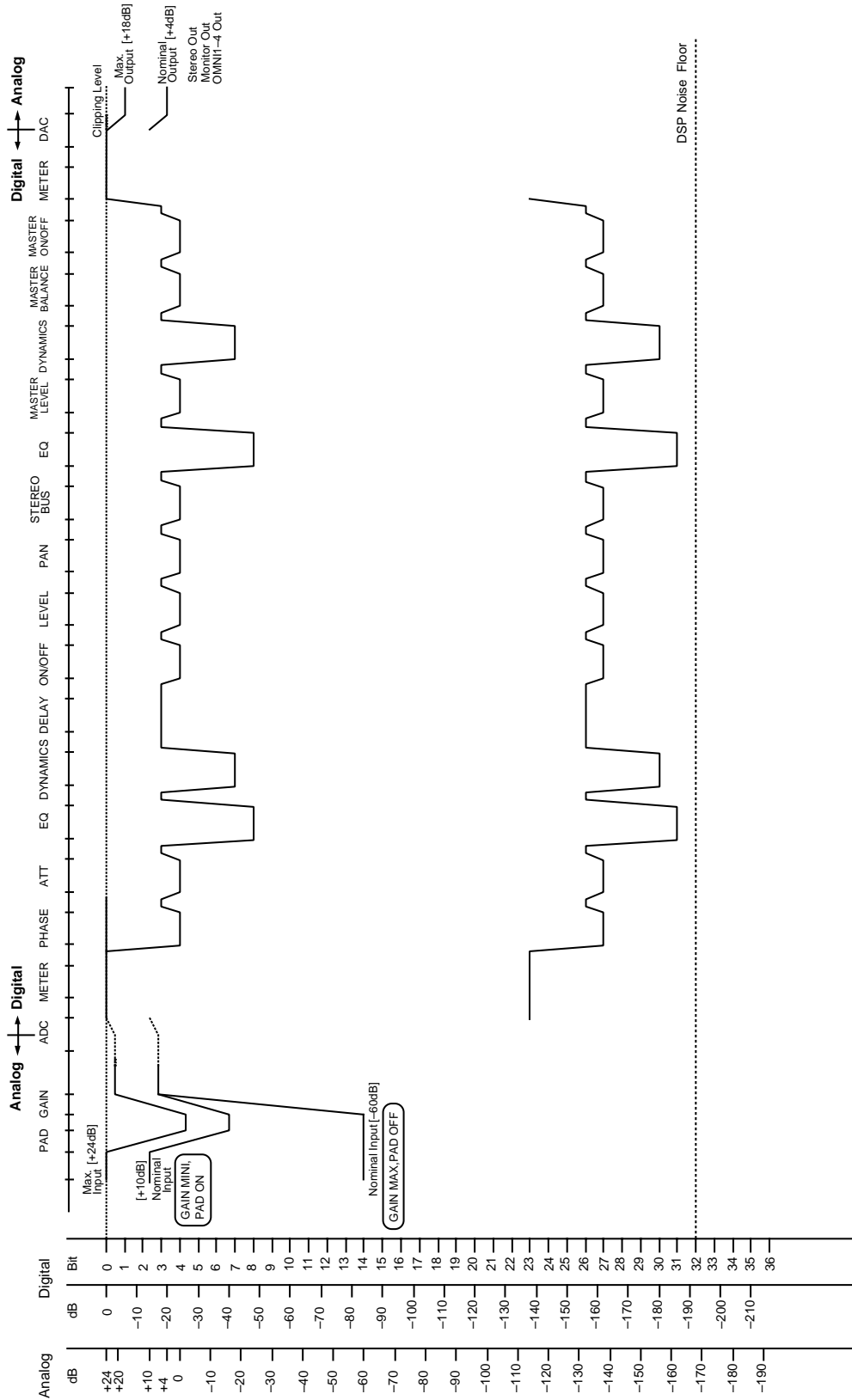

## Display Messages

Message	Meaning
<b>BULK: Byte Count Mismatch!</b>	The byte count of the received Bulk Dump data is not correct.
<b>BULK: Check Sum Error!</b>	The check sum of the received Bulk Dump data is not correct.
<b>BULK: Memory Protected!</b>	The Bulk Dump data cannot be stored because the destination is write-protected.
<b>DIGITAL IN Sync Error!</b>	This warning message appears if the Digital Stereo Coaxial In signal is not wordclock synchronized with the 01V. Make sure that all digital equipment is wordclock synchronized to a common wordclock source. See "Setting the Wordclock" on page 209 for more information. This warning message can be disabled by turning off the DIGITAL IN SYNC CAUTION option in the preferences ("Setting 01V Preferences" on page 203).
<b>For Effect2 Only.</b>	The selected effect program can be recalled only to Effect 2.
<b>LOW BATTERY!!</b>	The internal battery voltage is getting very low. Back up the Setup data ("Bulk Dump" on page 232), and ask your dealer to replace the battery.
<b>Memory Protected</b>	Cannot execute as selected scene memory is protected.
<b>MIDI IN: Framing Error!</b>	An incorrect signal may have been input to the MIDI IN.
<b>MIDI IN: Data Overrun!</b>	An incorrect signal may have been input to the MIDI IN.
<b>MIDI: Rx Buffer Full!</b>	The 01V is probably receiving too much MIDI data.
<b>MIDI: Tx Buffer Full!</b>	The 01V is probably transmitting too much MIDI data.
<b>NO DATA</b>	Cannot execute as no data has been stored.
<b>Now Fading(Fade Time).</b>	Local Control cannot be turned off while a mix-scene fade is in progress (Fade Time).
<b>OPTION IN Sync Error!</b>	This warning message appears if the Option I/O input digital signal is not wordclock synchronized with the 01V. Make sure that all digital equipment is wordclock synchronized to a common wordclock source. See "Setting the Wordclock" on page 209 for more information. This warning message can be disabled by turning off the DIGITAL IN SYNC CAUTION option in the preferences ("Setting 01V Preferences" on page 203).
<b>Read Only</b>	Cannot execute as selected scene memory is read only.
<b>Selected channel: CHxx</b>	CHxx is the selected channel.
<b>Preparing to LOCAL OFF...</b>	The MIDI Local Control function is preparing for use.
<b>TO HOST: Framing Error!</b>	An incorrect signal may have been input to the TO HOST connector.
<b>TO HOST: Data Overrun!</b>	An incorrect signal may have been input to the TO HOST connector.
<b>TO HOST: Data Parity Error!</b>	An incorrect signal may have been input to the TO HOST connector.
<b>TO HOST: Rx Buffer Full!</b>	The 01V is probably receiving too much MIDI data at the TO HOST connector.
<b>TO HOST: Tx Buffer Full!</b>	The 01V is probably transmitting too much MIDI data from the TO HOST connector.
<b>WRONG WORD CLOCK!</b>	The received wordclock is not correct and the 01V cannot synchronize correctly. Select a suitable wordclock, or use the AUTO NAVIGATE function on the SETUP page 1.

## Security Cover

For certain applications you may wish to fit a protective cover over the 01V's GAIN controls and PAD switches. Although Yamaha do not make such a cover, the 01V has four fixing holes to affix a custom-made cover. If you fit such a cover, make sure that the fixing screws do not protrude inside the 01V by more than 10 mm. The fixing holes accept M3-size machine screws, and are spaced 40.0 mm vertically, 414 mm horizontally.

## Rack-mounting Kit

The 01V can be rack mounted using the optional RK124 Rack Mount Kit. See your Yamaha dealer for details.

Attach the rack-mount brackets as shown below.

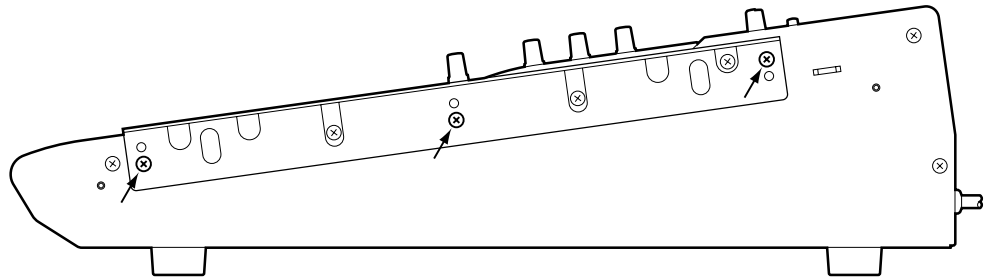

# Appendix B: Specifications

## General

<b>Sampling rate</b>	Internal	44.1 kHz
	External	44.1 kHz (-10%) to 48 kHz (+6%)
<b>Signal delay</b>		Less than 2.5 ms, $f_s=44.1$ kHz, CH IN to ST OUT
<b>Fader</b>		15 × 60 mm motorized
<b>Fader resolution</b>	Master faders except ST OUT	0 to -72, $-\infty$ dB (128 steps/60 mm)
	Other faders	+6 to -72, $-\infty$ dB (128 steps/60 mm)
	ST OUT fader	0 to -96, $-\infty$ dB (128 steps/60 mm)
<b>Total harmonic distortion</b> (Input gain min.)		Less than 0.1%, 20 Hz–20 kHz, +14 dB into 600 $\Omega$
		Less than 0.02%, 1 kHz, +18 dB into 600 $\Omega$ , CH IN to ST OUT
<b>Frequency response</b>		20 Hz–20 kHz +1, -3 dB, +4 dB into 600 $\Omega$
<b>Dynamic range</b> (maximum signal to noise level ratio)	D/A converter (ST OUT)	110 dB typ.
	A/D+D/A (to ST OUT)	105 dB typ.
<b>Hum &amp; Noise</b> (20 Hz–20 kHz) $R_s$ 150 $\Omega$ , Input gain max., Input pad 0 dB, Input sensitivity -60 dB Measured with a 6 dB/oct filter at 12.7 kHz; equivalent to a 20 kHz filter with an infinite dB/oct attenuation		-128 dB equivalent input noise
		-94 dB residual output noise, ST OUT off
		-94 dB (98 dB S/N) ST OUT, ST fader at nominal level and all CH IN faders at min.
		-64 dB (68 dB S/N) ST OUT fader at nominal level and one CH IN fader at nominal level.
<b>Maximum voltage gain</b>	CH IN (CH 1–12) to ST OUT/OMNI (BUS) OUT	70 dB
	CH IN (CH 1–12) to OMNI (AUX) OUT (pre input fader)	70 dB
	CH IN (CH 13–16) to ST OUT	30 dB
	CH IN (CH 1–12) to MONITOR OUT (via ST bus)	76 dB
<b>Crosstalk</b> (at 1 kHz)	Adjacent input channels (CH 1–12)	-70 dB
	Adjacent input channels (CH 13–16)	-60 dB
	Input to output	-70 dB

<b>Analog controls</b>	INPUT (1–12)	PAD (0/26 dB) GAIN (–16 to –60) PHANTOM +48 V switched (CH 1–6, 7–12)
	INPUT (13/14)	GAIN (+10 to –20)
	INPUT (15/16)	GAIN (+10 to –20) INPUT SELECT (15/16, 2TR IN)
	OUTPUT	MONITOR SELECT (2TR IN, MONITOR) MONITOR LEVEL CONTROL PHONES LEVEL CONTROL
<b>Digital controls</b>	ON & SEL buttons	CH 1–12 CH 13/14 CH 15/16 STEREO/MASTER (AUX 1–4, EFFECT 1, 2) RETURN 1, 2
	Faders	CH 1–12 CH 13/14 CH 15/16 STEREO/MASTER (AUX 1–4, EFFECT 1, 2)
	Encoders	RETURN 1, 2
	SOLO buttons	CH 1–12 CH 13/14 CH 15/16 RETURN 1, 2
	FADER MODE buttons	HOME, EFFECT 1, EFFECT 2, OPTION I/O, REMOTE, AUX 1, AUX 2, AUX 3, AUX 4
	SELECTED CHANNEL EQ buttons Encoders	HIGH, HI-MID, LO-MID, LOW PAN, F (EQ), G (EQ)
	Input control buttons	EQ/ATT, Ø/DELAY, DYNAMICS, PAN/ROUTING, VIEW
	Setup buttons	UTILITY, MIDI, SETUP, MEMORY
	Data entry Encoder Buttons	PARAMETER (24 detents) +1/INC, –1/DEC, ENTER
	CURSOR buttons	LEFT, RIGHT, UP, DOWN
<b>Display</b>	LCD	320 × 80 dot Graphic LCD w/backlight and contrast control
	LED	ST OUT meters, 12 elements × 2 SOLO mode indicator
<b>Power requirements</b>		U.S.A. & Canada 120 V AC, 60 Hz Europe 230 V AC, 50 Hz
<b>Power consumption</b>		70 W
<b>Dimensions (W × H × D)</b>		430 × 148 × 520 mm (16.9 × 5.8 × 20.4 inches)
<b>Weight</b>		12.5 kg (27.5 lbs)
<b>Free-air operating temperature range</b>		10° C to 35° C (50° F to 95° F)
<b>Security cover</b>		Four M3 fixing holes for custom-made cover
<b>Options</b>		Digital interface card (MY8, MY4 series), Rack-Mount Kit (RK124)

## Input Channels 1–16

<b>PHANTOM switch</b>	+48 V, CH 1-6, CH 7-12
<b>GAIN control</b>	44 dB (–60 to –16 dB), CH 1–12 detented 30 dB (–20 to +10 dB); CH 13/14, 15/16
<b>PAD switch</b>	0/26 dB attenuation CH 1–12
<b>AD converter</b>	20-bit linear 128-times oversampling
<b>Phase</b>	Normal/Reverse
<b>Input swap</b>	Normal (CH 1–8)/Swap (OPTION INPUT CH 17–24)
<b>Input flip</b>	Normal (CH 13/14)/Flip (DIGITAL STEREO IN)
<b>Input select switch</b>	CH 15/16–2TR IN
<b>Attenuator</b>	0 to –96 dB (1 dB steps)
<b>EQ</b>	4-band PEQ (Low, Lo-Mid, Hi-Mid, High)
<b>Dynamics</b>	Compressor, Gate, Ducking, Expander, Compander
<b>Delay</b>	0–250 ms, fs=44.1 kHz
<b>ON/OFF</b>	
<b>Fader</b>	60 mm motorized INPUT, AUX 1, AUX 2, AUX 3, AUX 4, EFFECT 1, EFFECT 2
<b>AUX, EFFECT send</b>	AUX 1–4, EFFECT 1, EFFECT 2 (pre/post fader)
<b>Solo</b>	ON/OFF AFL/PFL
<b>Pan</b>	33 positions (L1–16, CENTER, R1–16)
<b>Routing</b>	STEREO, BUS 1–4 Direct out (OMNI OUT 1–4, OPTION OUT via OUTPUT SELECT)
<b>Metering</b>	Displayed on LCD Peak hold ON/OFF

## Option I/O Inputs 17–24 (need optional card)

De-emphasis	Automatic de-emphasis filter (15 $\mu$ s/50 $\mu$ s)
Input swap	Normal (CH 17–24)/Swap (CH 1–8)
Attenuator	0 to –96 dB (1 dB steps)
EQ	2-band PEQ (Low, High)
ON/OFF	
Fader	60 mm motorized
AUX, EFFECT send	AUX 1, AUX 2, EFFECT 1, EFFECT 2 (pre/post fader)
Solo	ON/OFF AFL/PFL
Pan	33 positions (L1–16, CENTER, R1–16)
Routing	STEREO, BUS 1–4
Metering	Displayed on LCD Peak hold ON/OFF

## Digital Stereo In

De-emphasis	Automatic de-emphasis filter (15 $\mu$ s/50 $\mu$ s)
Input select	Normal (CH 13/14) / Flip (DIGITAL STEREO IN)
Cascade in	ON/OFF (to STEREO BUS)

## Return 1, 2 (Internal Effect 1, 2)

EQ	4-band PEQ
ON/OFF	
Level control	Rotary encoder INPUT, AUX 1, AUX 2, AUX 3, AUX 4, EFFECT 1, 2
AUX, EFFECT send	AUX 1–4, EFFECT 1, 2 (pre/post)
Solo	ON/OFF AFL/PFL
Pan	33 positions (L1–16, CENTER, R1–16)
Routing	STEREO, BUS 1–4
Metering	Displayed on LCD Peak hold ON/OFF



## Bus 1–4

Master level	
ON/OFF	
Monitor	ON/OFF AFL/PFL
BUS to STEREO	ON/OFF
PAN to STEREO	33 positions (L1–16, CENTER, R1–16)
Metering	Displayed on LCD Peak hold ON/OFF

## Aux 1–4

EQ	4-band PEQ (Low, Lo-Mid, Hi-Mid, High)
Dynamics	Compressor, Gate, Ducking, Expander, Compander
Fader	60 mm motorized
ON/OFF	
Monitor	ON/OFF AFL/PFL
Metering	Displayed on LCD Peak hold ON/OFF

## Stereo Out

EQ	4-band PEQ (Low, Lo-Mid, Hi-Mid, High)
Fader	60 mm motorized
Balance	
Dynamics	Compressor, Gate, Ducking, Expander, Compander
ON/OFF	
Delay	0–300 ms, $f_s=44.1$ kHz
Monitor	ON/OFF AFL/PFL
Metering	12-element $\times$ 2 LED meters. (post fader) and displayed on LCD
DA converter	20-bit linear 8-times oversampling

## Omni Out 1–4

Output select	CH 1–16, BUS 1–4, AUX 1–4, STEREO L, STEREO R
Delay	0–300 ms, $f_s=44.1$ kHz
DA converter	18-bit linear 8-times oversampling

## Monitor Out (Solo)

Solo trim	+6 to -60 dB (1 dB steps)
Mono	
DA converter	18-bit linear 8-times oversampling
SELECT switch	MONITOR/2TR IN
Level control	Analog rotary control
Phones level	Analog rotary control

## Digital Stereo Out

Dither	ON/OFF Word length: 16–24 bit
--------	----------------------------------

## Option I/O Output (need optional card)

Output select (MY8-AE, TD, AT)	OPTION OUT 1: BUS 1, CH 1, CH 9, AUX 1, ST OUT L OPTION OUT 2: BUS 2, CH 2, CH 10, AUX 2, ST OUT R OPTION OUT 3: BUS 3, CH 3, CH 11, AUX 3, ST OUT L OPTION OUT 4: BUS 4, CH 4, CH 12, AUX 4, ST OUT R OPTION OUT 5: BUS 1, CH 5, CH 13, AUX 1, ST OUT L OPTION OUT 6: BUS 2, CH 6, CH 14, AUX 2, ST OUT R OPTION OUT 7: BUS 3, CH 7, CH 15, AUX 3, ST OUT L OPTION OUT 8: BUS 4, CH 8, CH 16, AUX 4, ST OUT R
Output select (MY4-DA)	OPTION OUT 1: BUS 1, CH 1, CH 5, CH 9, CH 13, AUX 1, ST OUT L OPTION OUT 2: BUS 2, CH 2, CH 6, CH 10, CH 14, AUX 2, ST OUT R OPTION OUT 3: BUS 3, CH 3, CH 7, CH 11, CH 15, AUX 3, ST OUT L OPTION OUT 4: BUS 4, CH 4, CH 8, CH 12, CH 16, AUX 4, ST OUT R
Dither	ON/OFF Word length: 16–24 bit

## Memories & Libraries

Type	Total	Preset	User
Scene Memories	100	1	99
Effects Library	99	42	57
Dynamics Library	80	40	40
EQ Library	80	40	40

## EQ

	Low	Lo-Mid <sup>*1</sup>	Hi-Mid <sup>1</sup>	High
Gain (G)	-18.0 dB to +18.0 dB (0.5 dB steps) <sup>*2</sup>			
Frequency (F)	21 Hz–20.1 kHz (1/12 octave steps, 120 steps)			
Q	HPF, 10.0–0.10 (41 steps), L.SHELF	10.0–0.10 (41 steps)		LPF, 10.0–0.10 (41 steps), H.SHELF

\*1. 4-band EQs only (low and high bands only on input channels 17 through 24).

\*2. When the low and high EQ bands are configured as HPF and LPF, their gain controls function as filter on and off switches.

## Analog Inputs

Connection	PAD	GAIN	Actual Load Impedance	For Use With Nominal	Input level			Connector in Console
					Sensitivity* <sup>1</sup>	Nominal	Max. Before Clip	
Input channels 1–12	0	–60	3 k $\Omega$	50–600 $\Omega$ Mics & 600 $\Omega$ Lines	–66 dB (388 $\mu$ V)	–60 dB (775 $\mu$ V)	–46 dB (3.88 mV)	XLR-3-31 type (balanced) <sup>*2</sup> & TRS phone jack (balanced) <sup>*3</sup>
	0	–16			–22 dB (61.6 mV)	–16 dB (123 mV)	–2 dB (616 mV)	
	26				+4 dB (1.23 V)	+10 dB (2.45 V)	+24 dB (12.3 V)	
Input channels 13–16		–20	10 k $\Omega$	600 $\Omega$ Lines	–26 dB (38.8 mV)	–20 dB (77.5 mV)	–6 dB (388 mV)	TRS phone jack (balanced) <sup>3</sup>
		+10			+4 dB (1.23 V)	+10 dB (2.45 V)	+24 dB (12.3 V)	
2TR IN (L, R)			10 k $\Omega$	600 $\Omega$ Lines	–10 dBV (316 mV)	–10 dBV (316 mV)	+4 dBV (1.58 V)	Phono (unbalanced)

\*1. Sensitivity is the lowest level that will produce an output of +4 dB (1.23 V) or the nominal output level when the 01V is set to maximum gain (all faders and level controls at maximum positions).

\*2. Input channel XLR-type connectors are balanced (pin 1 = ground, pin 2 = hot, pin 3 = cold).

\*3. Input channel phone jacks are balanced (tip = hot, ring = cold, sleeve = ground).

\* Where dB represents a specific voltage, 0 dB is referenced to 0.775 V rms.

\* For 2TR IN levels, 0 dBV is referenced to 1.00 V rms.

\* Input channels 1–16 and ST IN use linear 20-bit 128-times oversampling A/D converters.

\* +48 V DC phantom powering switched in 6-channel blocks (1-6, 7-12) available via the XLR-type connectors of input channels 1–12

## Analog Outputs

Connection	Actual Source Impedance	For Use With Nominal	Output Level		Connector in Console
			Nominal	Max. Before Clip	
STEREO OUT (L, R)	150 $\Omega$	600 $\Omega$ Lines	+4 dB (1.23 V)	+18 dB (6.16 V)	XLR-3-32 type (balanced) <sup>*1</sup>
OMNI OUT (1–4)	150 $\Omega$	10 k $\Omega$ Lines	+4 dB (1.23 V)	+18 dB (6.16 V)	TRS phone jack (balanced) <sup>*2</sup>
2TR OUT (L, R)	600 $\Omega$	10 k $\Omega$ Lines	–10 dBV (316 mV)	+4 dBV (1.58 V)	Phono (unbalanced)
MONITOR OUT (L, R)	150 $\Omega$	10 k $\Omega$ Lines	+4 dB (1.23 V)	+18 dB (6.16 V)	TRS phone jack (balanced) <sup>2</sup>
PHONES	100 $\Omega$	8 $\Omega$ phones	4 mW	25 mW	Stereo phone jack (unbalanced) <sup>*3</sup>
		40 $\Omega$ phones	12 mW	75 mW	

\*1. STEREO OUT XLR-type connectors are balanced (pin 1 = ground, pin 2 = hot, pin 3 = cold).

\*2. OMNI/MONITOR OUT TRS phone jacks are balanced (tip = hot, ring = cold, sleeve = ground).

\*3. PHONES stereo phone jack is unbalanced (tip = send, ring = return, sleeve = ground).

\* For 2TR OUT, 0 dBV is referenced to 1.00 V rms.

\* Where dB represents a specific voltage, 0 dB is referenced to 0.775 V rms.

\* STEREO OUT uses 20-bit 8-times oversampling D/A converters.

\* OMNI OUT 1–4 and MONITOR OUT use 18-bit 8-times oversampling D/A converters.

## Digital Audio Inputs

Connection		Format	Wordlength	Level	Connector
DIGITAL STEREO IN*1	COAXIAL	IEC-60958	24 bit	0.5 V pp (75 Ω)	Phono

\*1. De-emphasis is automatically processed when input signal contains emphasis.

## Digital Audio Outputs

Connection		Format	Wordlength	Level	Connector
DIGITAL STEREO OUT	COAXIAL	IEC-60958*1 Consumer Use	24 bit*2	0.5 V pp (75 Ω)	Phono

\*1. Channel status

Type: 2 audio channels

Category code: 2 channel PCM encoder/decoder

Copy prohibit: No

Emphasis: No

Clock accuracy: Level II (1,000 ppm)

Sampling rate: depends on internal configuration

\*2. Dither: wordlength 16–24 bit

## Option I/O Cards

Card	Format	Inputs	Outputs
MY8-AT	ADAT	8 IN (CH 17–24)	8 OUT (BUS, AUX, ST, CH direct)
MY8-TD	TASCAM	8 IN (CH 17–24)	8 OUT (BUS, AUX, ST, CH direct)
MY8-AE	AES/EBU	8 IN (CH 17–24)	8 OUT (BUS, AUX, ST, CH direct)
MY4-DA	Analog out	—	4 OUT (BUS, AUX, ST, CH direct)
MY8-AD	Analog in	8 IN (CH 17–24)	—
MY4-AD	Analog in	4 IN (CH 17–20)	—

## Control I/O

Connection	Format	Level	Connector
TO HOST	—	RS-422	8-pin mini DIN
MIDI IN	MIDI	—	5-pin DIN
MIDI THRU	MIDI	—	5-pin DIN
MIDI OUT	MIDI	—	5-pin DIN

## 01V Dimensions

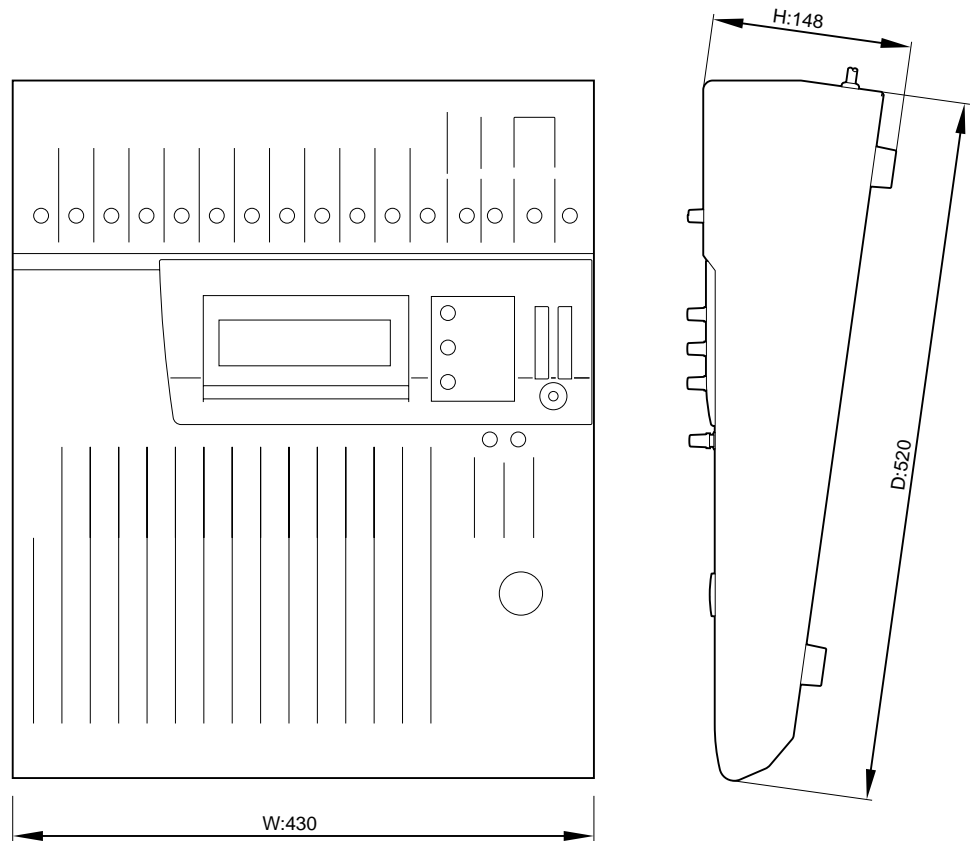

Specifications and external appearance are subject to change without notice.

For European Model

Purchaser/User Information specified in EN55103-1 and EN55103-2.

Inrush Current: 4A

Conformed Environment: E1, E2, E3 and E4

# Appendix C: MIDI

## Scene Memory to Program Change Table

Program Change #	Initial Scene #	User Scene #
1	01	
2	02	
3	03	
4	04	
5	05	
6	06	
7	07	
8	08	
9	09	
10	10	
11	11	
12	12	
13	13	
14	14	
15	15	
16	16	
17	17	
18	18	
19	19	
20	20	
21	21	
22	22	
23	23	
24	24	
25	25	
26	26	
27	27	
28	28	
29	29	
30	30	
31	31	
32	32	
33	33	
34	34	
35	35	
36	36	
37	37	
38	38	
39	39	
40	40	
41	41	
42	42	
43	43	

Program Change #	Initial Scene #	User Scene #
44	44	
45	45	
46	46	
47	47	
48	48	
49	49	
50	50	
51	51	
52	52	
53	53	
54	54	
55	55	
56	56	
57	57	
58	58	
59	59	
60	60	
61	61	
62	62	
63	63	
64	64	
65	65	
66	66	
67	67	
68	68	
69	69	
70	70	
71	71	
72	72	
73	73	
74	74	
75	75	
76	76	
77	77	
78	78	
79	79	
80	80	
81	81	
82	82	
83	83	
84	84	
85	85	
86	86	

Program Change#	Initial Scene #	User Scene #
87	87	
88	88	
89	89	
90	90	
91	91	
92	92	
93	93	
94	94	
95	95	
96	96	
97	97	
98	98	
99	99	
100	00	
101	—	
102	—	
103	—	
104	—	
105	—	
106	—	
107	—	
108	—	
109	—	
110	—	
111	—	
112	—	
113	—	
114	—	
115	—	
116	—	
117	—	
118	—	
119	—	
120	—	
121	—	
122	—	
123	—	
124	—	
125	—	
126	—	
127	—	
128	—	



## 01V Parameter to Control Change Table

Control Change #	Parameter					
	01V Initial (Default)			User		
0	NO ASSIGN					
1	FADER	CHANNEL	CH1			
2	FADER	CHANNEL	CH2			
3	FADER	CHANNEL	CH3			
4	FADER	CHANNEL	CH4			
5	FADER	CHANNEL	CH5			
6	FADER	CHANNEL	CH6			
7	FADER	CHANNEL	CH7			
8	FADER	CHANNEL	CH8			
9	FADER	CHANNEL	CH9			
10	FADER	CHANNEL	CH10			
11	FADER	CHANNEL	CH11			
12	FADER	CHANNEL	CH12			
13	FADER	CHANNEL	CH13-14			
14	FADER	CHANNEL	CH15-16			
15	FADER	CHANNEL	RETURN1			
16	FADER	CHANNEL	RETURN2			
17	FADER	MASTER	AUX1			
18	FADER	MASTER	AUX2			
19	FADER	MASTER	AUX3			
20	FADER	MASTER	AUX4			
21	FADER	MASTER	BUS1			
22	FADER	MASTER	BUS2			
23	FADER	MASTER	BUS3			
24	FADER	MASTER	BUS4			
25	FADER	MASTER	EFFECT1			
26	FADER	MASTER	EFFECT2			
27	FADER	MASTER	ST OUT			
28	ON	CHANNEL	CH1			
29	ON	CHANNEL	CH2			
30	ON	CHANNEL	CH3			
31	ON	CHANNEL	CH4			
32	NO ASSIGN					
33	ON	CHANNEL	CH5			
34	ON	CHANNEL	CH6			
35	ON	CHANNEL	CH7			
36	ON	CHANNEL	CH8			
37	ON	CHANNEL	CH9			

Control Change #	Parameter			User		
	01V Initial (Default)					
38	ON	CHANNEL	CH10			
39	ON	CHANNEL	CH11			
40	ON	CHANNEL	CH12			
41	ON	CHANNEL	CH13-14			
42	ON	CHANNEL	CH15-16			
43	ON	CHANNEL	RETURN1			
44	ON	CHANNEL	RETURN2			
45	ON	MASTER	AUX1			
46	ON	MASTER	AUX2			
47	ON	MASTER	AUX3			
48	ON	MASTER	AUX4			
49	ON	MASTER	BUS1			
50	ON	MASTER	BUS2			
51	ON	MASTER	BUS3			
52	ON	MASTER	BUS4			
53	ON	MASTER	EFFECT1			
54	ON	MASTER	EFFECT2			
55	ON	MASTER	ST OUT			
56	PAN	CHANNEL	CH1			
57	PAN	CHANNEL	CH2			
58	PAN	CHANNEL	CH3			
59	PAN	CHANNEL	CH4			
60	PAN	CHANNEL	CH5			
61	PAN	CHANNEL	CH6			
62	PAN	CHANNEL	CH7			
63	PAN	CHANNEL	CH8			
64	PAN	CHANNEL	CH9			
65	PAN	CHANNEL	CH10			
66	PAN	CHANNEL	CH11			
67	PAN	CHANNEL	CH12			
68	PAN	CHANNEL	CH13			
69	PAN	CHANNEL	CH14			
70	PAN	CHANNEL	CH15			
71	PAN	CHANNEL	CH16			
72	PAN	CHANNEL	RETURN1 L			
73	PAN	CHANNEL	RETURN1 R			
74	PAN	CHANNEL	RETURN2 L			
75	PAN	CHANNEL	RETURN2 R			
76	PAN	BALANCE	ST OUT			
77	FADER	EFF1 SEND	CH1			
78	FADER	EFF1 SEND	CH2			
79	FADER	EFF1 SEND	CH3			

Control Change #	Parameter			User		
	01V Initial (Default)					
80	FADER	EFF1 SEND	CH4			
81	FADER	EFF1 SEND	CH5			
82	FADER	EFF1 SEND	CH6			
83	FADER	EFF1 SEND	CH7			
84	FADER	EFF1 SEND	CH8			
85	FADER	EFF1 SEND	CH9			
86	FADER	EFF1 SEND	CH10			
87	FADER	EFF1 SEND	CH11			
88	FADER	EFF1 SEND	CH12			
89	FADER	EFF1 SEND	CH13-14			
90	FADER	EFF1 SEND	CH15-16			
91	FADER	EFF2 SEND	CH1			
92	FADER	EFF2 SEND	CH2			
93	FADER	EFF2 SEND	CH3			
94	FADER	EFF2 SEND	CH4			
95	FADER	EFF2 SEND	CH5			
102	FADER	EFF2 SEND	CH6			
103	FADER	EFF2 SEND	CH7			
104	FADER	EFF2 SEND	CH8			
105	FADER	EFF2 SEND	CH9			
106	FADER	EFF2 SEND	CH10			
107	FADER	EFF2 SEND	CH11			
108	FADER	EFF2 SEND	CH12			
109	FADER	EFF2 SEND	CH13-14			
110	FADER	EFF2 SEND	CH15-16			
111	FADER	CHANNEL	CH17			
112	FADER	CHANNEL	CH18			
113	FADER	CHANNEL	CH19			
114	FADER	CHANNEL	CH20			
115	FADER	CHANNEL	CH21			
116	FADER	CHANNEL	CH22			
117	FADER	CHANNEL	CH23			
118	FADER	CHANNEL	CH24			
119	NO ASSIGN					

## 03D & Programmable Mixer 01 Parameter to Control Change Table

Control Change #	Parameter					
	03D Arrangement			Programmable Mixer 01 Arrangement		
0	NO ASSIGN			FADER	CHANNEL	CH1
1	FADER	CHANNEL	CH1	FADER	CHANNEL	CH2
2	FADER	CHANNEL	CH2	FADER	CHANNEL	CH3
3	FADER	CHANNEL	CH3	FADER	CHANNEL	CH4
4	FADER	CHANNEL	CH4	FADER	CHANNEL	CH5
5	FADER	CHANNEL	CH5	FADER	CHANNEL	CH6
6	FADER	CHANNEL	CH6	FADER	CHANNEL	CH7
7	FADER	CHANNEL	CH7	FADER	CHANNEL	CH8
8	FADER	CHANNEL	CH8	FADER	CHANNEL	CH9
9	FADER	CHANNEL	CH9	FADER	CHANNEL	CH10
10	FADER	CHANNEL	CH10	FADER	CHANNEL	CH11
11	FADER	CHANNEL	CH11	FADER	CHANNEL	CH12
12	FADER	CHANNEL	CH12	FADER	CHANNEL	CH17
13	NO ASSIGN			FADER	CHANNEL	CH18
14	NO ASSIGN			FADER	CHANNEL	CH19
15	NO ASSIGN			FADER	CHANNEL	CH20
16	NO ASSIGN			FADER	CHANNEL	CH13-14
17	FADER	CHANNEL	CH17	FADER	CHANNEL	RETURN1
18	FADER	CHANNEL	CH18	FADER	CHANNEL	RETURN2
19	FADER	CHANNEL	CH19	FADER	MASTER	AUX1
20	FADER	CHANNEL	CH20	FADER	MASTER	AUX2
21	FADER	CHANNEL	CH21	FADER	MASTER	ST OUT
22	FADER	CHANNEL	CH22	ON	CHANNEL	CH1
23	FADER	CHANNEL	CH23	ON	CHANNEL	CH2
24	FADER	CHANNEL	CH24	ON	CHANNEL	CH3
25	FADER	CHANNEL	CH13-14	ON	CHANNEL	CH4
26	FADER	CHANNEL	RETURN1	ON	CHANNEL	CH5
27	FADER	CHANNEL	RETURN2	ON	CHANNEL	CH6
28	FADER	MASTER	AUX1	ON	CHANNEL	CH7
29	FADER	MASTER	AUX2	ON	CHANNEL	CH8
30	FADER	MASTER	AUX3	ON	CHANNEL	CH9
31	FADER	MASTER	AUX4	ON	CHANNEL	CH10
32	NO ASSIGN			ON	CHANNEL	CH11
33	FADER	MASTER	BUS1	ON	CHANNEL	CH12
34	FADER	MASTER	BUS2	ON	CHANNEL	CH17
35	FADER	MASTER	BUS3	ON	CHANNEL	CH18
36	FADER	MASTER	BUS4	ON	CHANNEL	CH19
37	FADER	MASTER	ST OUT	ON	CHANNEL	CH20

Control Change #	Parameter					
	03D Arrangement			Programmable Mixer 01 Arrangement		
38	PAN	CHANNEL	CH1	ON	CHANNEL	CH13-14
39	PAN	CHANNEL	CH2	ON	CHANNEL	RETURN1
40	PAN	CHANNEL	CH3	ON	CHANNEL	RETURN2
41	PAN	CHANNEL	CH4	ON	MASTER	AUX1
42	PAN	CHANNEL	CH5	ON	MASTER	AUX2
43	PAN	CHANNEL	CH6	ON	MASTER	ST OUT
44	PAN	CHANNEL	CH7	PAN	CHANNEL	CH1
45	PAN	CHANNEL	CH8	PAN	CHANNEL	CH2
46	PAN	CHANNEL	CH9	PAN	CHANNEL	CH3
47	PAN	CHANNEL	CH10	PAN	CHANNEL	CH4
48	PAN	CHANNEL	CH11	PAN	CHANNEL	CH5
49	PAN	CHANNEL	CH12	PAN	CHANNEL	CH6
50			NO ASSIGN	PAN	CHANNEL	CH7
51			NO ASSIGN	PAN	CHANNEL	CH8
52			NO ASSIGN	PAN	CHANNEL	CH9
53			NO ASSIGN	PAN	CHANNEL	CH10
54	PAN	CHANNEL	CH17	PAN	CHANNEL	CH11
55	PAN	CHANNEL	CH18	PAN	CHANNEL	CH12
56	PAN	CHANNEL	CH19	PAN	CHANNEL	CH17
57	PAN	CHANNEL	CH20	PAN	CHANNEL	CH18
58	PAN	CHANNEL	CH21	PAN	CHANNEL	CH19
59	PAN	CHANNEL	CH22	PAN	CHANNEL	CH20
60	PAN	CHANNEL	CH23	PAN	CHANNEL	CH13
61	PAN	CHANNEL	CH24	PAN	CHANNEL	CH14
62	PAN	CHANNEL	CH13	PAN	CHANNEL	RETURN1 L
63	PAN	CHANNEL	CH14	PAN	CHANNEL	RETURN1 R
64	ON	CHANNEL	CH1	PAN	CHANNEL	RETURN2 L
65	ON	CHANNEL	CH2	PAN	CHANNEL	RETURN2 R
66	ON	CHANNEL	CH3			NO ASSIGN
67	ON	CHANNEL	CH4	PAN	BALANCE	ST OUT
68	ON	CHANNEL	CH5	FADER	EFF1 SEND	CH1
69	ON	CHANNEL	CH6	FADER	EFF1 SEND	CH2
70	ON	CHANNEL	CH7	FADER	EFF1 SEND	CH3
71	ON	CHANNEL	CH8	FADER	EFF1 SEND	CH4
72	ON	CHANNEL	CH9	FADER	EFF1 SEND	CH5
73	ON	CHANNEL	CH10	FADER	EFF1 SEND	CH6
74	ON	CHANNEL	CH11	FADER	EFF1 SEND	CH7
75	ON	CHANNEL	CH12	FADER	EFF1 SEND	CH8
76			NO ASSIGN	FADER	EFF1 SEND	CH9
77			NO ASSIGN	FADER	EFF1 SEND	CH10
78			NO ASSIGN	FADER	EFF1 SEND	CH11
79			NO ASSIGN	FADER	EFF1 SEND	CH12

Control Change #	Parameter					
	03D Arrangement			Programmable Mixer 01 Arrangement		
80	ON	CHANNEL	CH17	FADER	EFF1 SEND	CH17
81	ON	CHANNEL	CH18	FADER	EFF1 SEND	CH18
82	ON	CHANNEL	CH19	FADER	EFF1 SEND	CH19
83	ON	CHANNEL	CH20	FADER	EFF1 SEND	CH20
84	ON	CHANNEL	CH21	FADER	EFF1 SEND	CH13-14
85	ON	CHANNEL	CH22	FADER	EFF2 SEND	CH1
86	ON	CHANNEL	CH23	FADER	EFF2 SEND	CH2
87	ON	CHANNEL	CH24	FADER	EFF2 SEND	CH3
88	ON	CHANNEL	CH13-14	FADER	EFF2 SEND	CH4
89	ON	CHANNEL	RETURN1	FADER	EFF2 SEND	CH5
90	ON	CHANNEL	RETURN2	FADER	EFF2 SEND	CH6
91	ON	MASTER	AUX1	FADER	EFF2 SEND	CH7
92	ON	MASTER	AUX2	FADER	EFF2 SEND	CH8
93	ON	MASTER	AUX3	FADER	EFF2 SEND	CH9
94	ON	MASTER	AUX4	FADER	EFF2 SEND	CH10
95	ON	MASTER	ST OUT	FADER	EFF2 SEND	CH11
102	FADER	EFF1 SEND	CH1	FADER	AUX1 SEND	CH1
103	FADER	EFF1 SEND	CH2	FADER	AUX1 SEND	CH2
104	FADER	EFF1 SEND	CH3	FADER	AUX1 SEND	CH3
105	FADER	EFF1 SEND	CH4	FADER	AUX1 SEND	CH4
106	FADER	EFF1 SEND	CH5	FADER	AUX1 SEND	CH5
107	FADER	EFF1 SEND	CH6	FADER	AUX1 SEND	CH6
108	FADER	EFF1 SEND	CH7	FADER	AUX1 SEND	CH7
109	FADER	EFF1 SEND	CH8	FADER	AUX1 SEND	CH8
110	FADER	EFF1 SEND	CH9	FADER	AUX1 SEND	CH9
111	FADER	EFF1 SEND	CH10	FADER	AUX1 SEND	CH10
112	FADER	EFF1 SEND	CH11	FADER	AUX1 SEND	CH11
113	FADER	EFF1 SEND	CH12	FADER	AUX1 SEND	CH12
114			NO ASSIGN	FADER	AUX1 SEND	CH17
115			NO ASSIGN	FADER	AUX1 SEND	CH18
116			NO ASSIGN	FADER	AUX1 SEND	CH19
117			NO ASSIGN	FADER	AUX1 SEND	CH20
118	FADER	EFF1 SEND	CH13-14	FADER	AUX1 SEND	CH13-14
119	FADER	BALANCE	ST OUT			NO ASSIGN

# MIDI Data Format

## 1. TRANSMIT/RECEIVE DATA

### 1.1 CHANNEL MESSAGE

#### 1.1.1 NOTE OFF (8n)

##### Reception

Received if [Rx CH] matches.

Used for EFFECT control. See below for details.

STATUS	1000nnnn	8n	Note Off Message
DATA	0nnnnnnn	nn	Note No.
	0vvvvvvv	vv	Velocity ( ignored)

#### 1.1.2 NOTE ON (9n)

##### Reception

Received if [Rx CH] matches.

Used for EFFECT control. See below for details.

A velocity of 0x00 is the same as NOTE OFF.

STATUS	1001nnnn	9n	Note On Message
DATA	0nnnnnnn	nn	Note No.
	0vvvvvvv	vv	Velocity ( 1-127:On, 0:off)

\* Using Note data for EFFECT control

1: Dynamic Flange/Dynamic Phase/Dynamic Filter

When the SOURCE parameter is set to MIDI, Velocity will be used together with Note On/Off to control the frequency width of Modulation.

2: Freeze

When PLAY MODE is MOMENT or CONTINUE, a Note On message will start play. However, this is only when the note number specified for MIDI TRG is received. Also, play will not occur if there is no recorded data.

Regardless of the Note Number, a Note Off message will stop play if PLAY MODE is MOMENT.

#### 1.1.3 CONTROL CHANGE (Bn)

##### Reception

Received when [Control Change RX] is ON and the [Rx CH] matches. However if [OMNI] is ON, this message is received regardless of the channel.

When [Control Change ECHO] is ON, this message will be echoed. Parameters will be controlled according to the settings of the [control assign table].

Control of specific faders can be disabled by the [midi fader control input mute] settings.

If this message is received while the [control assign table] page is displayed, the cursor location will move to that control number.

##### Transmission

If [Control Change TX] is ON, this message is transmitted on the [Tx CH] whenever a parameter specified in the [control assign table] is operated.

If [Control Change ECHO] is ON, these messages will be merged with the unit's own output while taking advantage of running status.

STATUS	1011nnnn	Bn	Control Change
DATA	0ccccccc	cc	Control No. ( 0-95, 102-119)
	0vvvvvvv	vv	Control Value (0-127)

The control value is converted to the parameter value according to the following equation.

$C = 128$  (byte parameter)

16384 (word parameter)

$S =$  number of total possible steps for the parameter

$C / S = X$  remainder  $Y$

$INT((Y+1)/2) = Z$

If (MIDI DATA - Z) < 0 then -> param = 0

If ((MIDI DATA - Z)/X) > MAX then -> param = MAX

In other cases -> param =

$INT((MIDI DATA - Z)/X)$

#### 1.1.4 PROGRAM CHANGE (Cn)

##### Reception

Received when [Program Change RX] is ON if the [Rx CH] matches.

However if [OMNI] is ON, this is received regardless of the channel. This is echoed if [Program Change ECHO] is ON.

A scene memory will be recalled according to the settings of the [Program change table].

##### Transmission

If [Program Change TX] is ON, this is transmitted on the [Tx CH] channel when a scene memory is recalled.

If two or more program numbers have been assigned to the memory number which was recalled, the lowest numbered program number will be transmitted.

This message is echoed if [Program Change ECHO] is ON. (If a memory number which is not specified in the [Midi Program Change Assign Table] is recalled, the Parameter Change (Function Call) described below will be transmitted.)

STATUS	1100nnnn	Cn	Program Change
DATA	0nnnnnnn	nn	Program No. ( 0-127)

### 1.2 EXCLUSIVE MESSAGE (F0-F7)

#### 1.2.1 MOTION CONTROL STATE (MCS)

##### MMC STOP/PLAY/FORWARD/REWIND/RECORD/PAUSE

##### Transmission

In the [REMOTE-MMC] page, this is transmitted by key operations. The [DEVICE NO.] specifies the transmission destination.

STATUS	11110000	F0	System Exclusive Message
ID No.	01111111	7F	Real Time System Exclusive
Device ID	0ddddddd	dd	Destination (00-7E, 7F:all call)
Command	00000110	06	Machine Control Command(mcc) sub-id
	0ccccccc	cc	Command String
			[1]:Stop
			[2]:Play
			[4]:Fast Forward
			[5]:Rewind
			[6]:Record Stroke
			[9]:Pause
EOX	11110111	F7	End Of Exclusive

#### 1.2.2 MOTION CONTROL PROCESS (MCP)

##### MMC LOCATE (target)

##### Transmission

In the [REMOTE-MMC] page, this is transmitted by key operations. The [DEVICE NO.] specifies the transmission destination. (The ID of the receiving device must be set.)

STATUS	11110000	F0	System Exclusive Message
ID No.	01111111	7F	Real Time System Exclusive
Device ID	0ddddddd	dd	Destination (00-7E, 7F:all call)
Command	00000110	06	Machine Control Command(mcc) sub-id
	01000100	44	Locate
	00000110	06	byte count
	00000001	01	"target" sub command
	0hhhhhhh	hh	hour
	0mmmmmmm	mm	minute
	0sssssss	ss	second
	0ffffff	ff	frame
	0sssssss	ss	sub-frame( only '0')
EOX	11110111	F7	End Of Exclusive

### 1.3 ACTIVE SENSING (Fe)

#### Reception

Once this message has been received, an interval of 300ms or more during which no message is received will cause MIDI communications to be initialized, clearing Running Status etc.

STATUS 11111110 FE Active Sensing

## 2. TRANSMISSION CONDITION

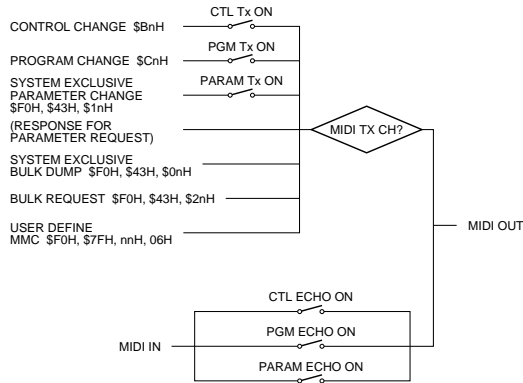

## 3. RECEIVE CONDITION

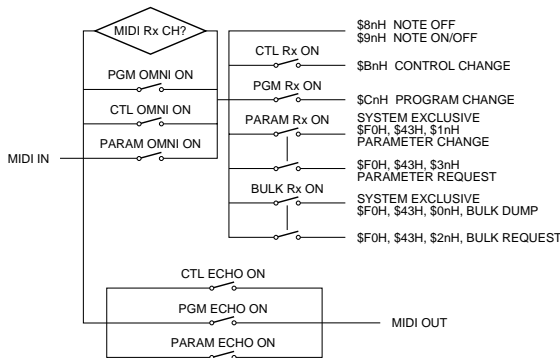

## 4. PARAMETER CHANGE

### BASIC FORMAT

STATUS	11110000 F0	System Exclusive Message
ID No.	01000011 43	Manufacturer's ID No.(YAMAHA)
SUB STATUS	0ppppnnn pn	p=mode 1:parameter change or response for request, 3:parameter request n=0-15(Device Channel No.1-16)
GROUP ID	00111110 3e	MODEL ID (digital mixer)
MODEL ID	00000100 04	Device code (01V)
PARAM TYPE	0ttttttt tt	(type)
DATA	0ddddd dd0	data 0
	:	:
	0ddddd ddn	data n
EOX	11110111 F7	End Of Exclusive

type

0x00	edit buffer ...byte operation format
0x01	system memory (setup, backup) ...byte operation format
0x02	function call (mem/lib recall, mem/lib store, clear, title)
0x03	controller (LCD/fader mode)...byte operation format
0x04	multiple link (fader mode, solo mode, title,...)
0x05	remote meter (meter data)
0x10	edit buffer ...7bit operation format
0x40	edit buffer ...bit operation format
0x41	system memory (setup, backup) ...bit operation format
0x43	controller (key remote) ...bit operation format

### PARAMETER CHANGE (byte operation for type 0x00:edit buffer)

#### Reception

This message is received if [Parameter Change RX] is ON and the [Rx CH] matches the Device Channel included in the SUB STATUS. If [Parameter Change ECHO] is ON, this will be echoed. The specified parameter will be controlled when this message is received.

#### Transmission

If [Parameter Change TX] is ON, this message will be transmitted on the [Tx CH] Device Channel when a parameter that is not specified in the [Control Assign Table] is modified.

STATUS	11110000 F0	System Exclusive Message
ID No.	01000011 43	Manufacturer's ID No.(YAMAHA)
SUB STATUS	0001nnnn 1n	parameter change or response n=0-15(Device Channel No.1-16)
GROUP ID	00111110 3e	MODEL ID
MODEL ID	00000100 04	Device code (01V)
PARAM TYPE	00000000 00	byte operation for edit buffer (type)
DATA	0aaaaaaaa dd1	address (H) high 7 bits of 14 bits address
	0aaaaaaaa dd2	address (L) low 7 bits of 14 bits address
	0000dddd dd3	data (H) high 4 bits of 8 bits data
	0000dddd dd4	data (L) low 4 bits of 8 bits data
	:	: continuous address datas
EOX	11110111 F7	End Of Exclusive

The valid range of addresses is 0x0000 - 0x03FF



**PARAMETER CHANGE (7bit operation for type 0x10:edit buffer)****Reception**

This message is received if [Parameter Change RX] is ON and the [Rx CH] matches the Device Channel included in the SUB STATUS. This is echoed if [Parameter Change ECHO] is ON. When this is received, the specified parameter will be controlled.

**Transmission**

If [Parameter Change TX] is ON, this message is transmitted on the [Tx CH] Device Channel when a parameter not specified in the [Control Assign Table] is modified.

STATUS	11110000	F0	System Exclusive Message
ID No.	01000011	43	Manufacturer's ID No.(YAMAHA)
SUB STATUS	0001nnnn	1n	parameter change n=0-15(Device Channel No.1-16)
GROUP ID	00111110	3e	MODEL ID
MODEL ID	00000100	04	Device code (01V)
PARAM TYPE	00010000	10	7bit operation for edit buffer (type)
DATA	0aaaaaaa	dd0	address( H) high 7 bits of 14 bits address
	0aaaaaaa	dd1	address( L) low 7 bits of 14 bits address
	0ddddd	dd2	data 7bit
	:	:	:
EOX	11110111	F7	End Of Exclusive

The valid range of addresses is 0x0000 - 0x03FF

**PARAMETER CHANGE (bit operation for type 0x40:edit buffer)****Reception**

When [Parameter Change RX] is ON, this message is received if the [Rx CH] matches the Device Channel included in the SUB STATUS. If [Parameter Change ECHO] is ON, this message will be echoed. When this message is received, the specified parameter will be controlled.

**Transmission**

If [Parameter Change TX] is ON, this message is transmitted on the [Tx CH] Device Channel when a parameter not specified in the [Control Assign Table] is modified.

STATUS	11110000	F0	System Exclusive Message
ID No.	01000011	43	Manufacturer's ID No.(YAMAHA)
SUB STATUS	0001nnnn	1n	parameter change n=0-15(Device Channel No.1-16)
GROUP ID	00111110	3e	MODEL ID
MODEL ID	00000100	04	Device code (01V)
PARAM TYPE	01000000	40	bit operation for edit buffer (type)
DATA	0aaaaaaa	dd0	address( H) high 7 bits of 14 bits address
	0aaaaaaa	dd1	address( L) low 7 bits of 14 bits address
	0ddddd	dd2	data(bit0-2:change bit no.0-7, bit3:0=reset 1=set)
	:	:	:
EOX	11110111	F7	End Of Exclusive

The valid range of addresses is 0x0000 - 0x03FF

**PARAMETER CHANGE (byte operation for type 0x01:system memory)****Reception**

When [Parameter Change RX] is ON, this message is received if the [Rx CH] matches the Device Channel included in the SUB STATUS. When [Parameter Change ECHO] is ON, this is echoed. When this is received, the specified parameter will be controlled.

STATUS	11110000	F0	System Exclusive Message
ID No.	01000011	43	Manufacturer's ID No.(YAMAHA)
SUB STATUS	0001nnnn	1n	parameter change or response n=0-15(Device Channel No.1-16)
GROUP ID	00111110	3e	MODEL ID
MODEL ID	00000100	04	Device code (01V)
PARAM TYPE	00000001	01	byte operation for system memory (type)
DATA	0aaaaaaa	dd0	address( H) high 7 bits of 14 bits address
	0aaaaaaa	dd1	address( L) low 7 bits of 14 bits address
	0000ddd	dd2	data( H) high 4 bits of 8 bits data
	0000ddd	dd3	data( L) low 4 bits of 8 bits data
	:	:	: continuous address datas
EOX	11110111	F7	End Of Exclusive

The system memory will depend on the address, as follows.

0x0000 - 0x007F	: setup memory(128byte)
0x0080 - 0x0147	: backup memory(200byte)
0x0200	: card type(1byte)

**PARAMETER CHANGE (bit operation for type 0x41:system memory)****Reception**

When [Parameter Change RX] is ON, this message is received if the [Rx CH] matches the Device Channel included in the SUB STATUS. When [Parameter Change ECHO] is ON, this is echoed. When this is received, the specified parameter will be controlled.

STATUS	11110000	F0	System Exclusive Message
ID No.	01000011	43	Manufacturer's ID No.(YAMAHA)
SUB STATUS	0001nnnn	1n	parameter change or response n=0-15(Device Channel No.1-16)
GROUP ID	00111110	3e	MODEL ID
MODEL ID	00000100	04	Device code (01V)
PARAM TYPE	01000001	41	bit operation for system memory (type)
DATA	0aaaaaaa	dd0	address( H) high 7 bits of 14 bits address
	0aaaaaaa	dd1	address( L) low 7 bits of 14 bits address
	0ddddd	dd2	data(bit0-2:change bit no.0-7, bit3:0=reset 1=set)
	:	:	:
EOX	11110111	F7	End Of Exclusive

The system memory will depend on the address, as follows.

0x0000 - 0x007F	: setup memory(128byte)
0x0080 - 0x0147	: backup memory(200byte)

**PARAMETER VALUE REQUEST (type 0x00:edit buffer, 0x01:system memory)**

**Reception**

When [Parameter Change RX] is ON, this message is received if the [Rx CH] matches the Device Channel included in the SUB STATUS. When [Parameter Change ECHO] is ON, this message will be echoed if the device itself did not receive the message.

When this message is received, the value of the specified parameter will be transmitted as a Parameter Change message.

**Transmission**

When [Parameter Change ECHO] is ON, this message will be transmitted without change if the device itself did not receive the message.

STATUS	11110000 F0	System Exclusive Message
ID No.	01000011 43	Manufacturer's ID No.(YAMAHA)
SUB STATUS	0011nnnn 3n	parameter request n=0-15(Device Channel No.1-16)
GROUP ID	00111110 3e	MODEL ID
MODEL ID	00000100 04	Device code (01V)
PARAM TYPE	00tttttt tt	00:edit buffer, 01:system memory (type)
DATA	0aaaaaaa dd0	address( H) high 7 bits of 14 bits address
	0aaaaaaa dd1	address( L) low 7 bits of 14 bits address
	0ddddd dd	count
EOX	11110111 F7	End Of Exclusive

The system memory will depend on the address, as follows.

- 0x0000 - 0x007F : setup memory(128byte)
- 0x0080 - 0x0147 : backup memory(200byte)
- 0x0200 : card type(1byte)

**PARAMETER CHANGE (type 0x02:function call)**

**Reception**

When [Parameter Change RX] is ON, this message is received if the [Rx CH] matches the Device Channel included in the SUB STATUS. When [Parameter Change ECHO] is ON, this message will be echoed.

When this message is received, the corresponding memory/library/table will be recalled/stored/cleared.

STATUS	11110000 F0	System Exclusive Message
ID No.	01000011 43	Manufacturer's ID No.(YAMAHA)
SUB STATUS	0001nnnn 1n	parameter change n=0-15(Device Channel No.1-16)
GROUP ID	00111110 3e	MODEL ID
MODEL ID	00000100 04	Device code (01V)
PARAM TYPE	00000010 02	function call
DATA	0ddddd dd0	function
	0ddddd dd1	number
	0ddddd dd2	channel
EOX	11110111 F7	End Of Exclusive

function	number	channel	Tx/Rx
0x00 scene recall	0-99(memory 0-99)	0x7f	Tx*/Rx
0x01 eq lib recall	0-79(library 1-80)	0-19,22	Tx/Rx
0x02 dyn lib recall	0-79(library 1-80)	0-13,16-19,22	Tx/Rx
0x03 eff lib recall	0-98(library 1-99)	0,1	Tx/Rx
0x10 scene store	1-99(memory 1-99)	0x7f	Rx only
0x11 eq lib store	40-79(library 41-80)	0-19,22	Rx only
0x12 dyn lib store	40-79(library 41-80)	0-13,16-19,22	Rx only
0x13 eff lib store	42-98(library 43-99)	0,1	Rx only
Channel	0-11(ch1-12), 12-13(13/14-15/16), 14-15(return 1-2), 16-19(aux 1-4), 22(st mas), 23-30(ch17-24)		
	0,1(EFF1,2 for eff lib recall/store), 0x7f(current/edit buffer)		

\* [0x00:scene recall] is transmitted only when a program which is not assigned to the program change table has been recalled. In other cases, a program change will normally be transmitted.

**PARAMETER CHANGE (type 0x02:function call(title))**

**Reception**

When [Parameter Change RX] is ON and the [Rx CH] matches the Device Channel included in the SUB STATUS, this message will be received.

When [Parameter Change ECHO] is ON, this message will be echoed.

When this message is received, the title of the corresponding memory/library will be modified.

**Transmission**

Parameter Change messages are transmitted on the [Rx CH] channel in response to a request.

STATUS	11110000 F0	System Exclusive Message
ID No.	01000011 43	Manufacturer's ID No.(YAMAHA)
SUB STATUS	0001nnnn 1n	parameter change or response n=0-15(Device Channel No.1-16)
GROUP ID	00111110 3e	MODEL ID
MODEL ID	00000100 04	Device code (01V)
PARAM TYPE	00000010 02	function call
DATA	0ddddd dd0	function
	0ddddd dd1	number
	0ddddd dd2	title1(If data is empty, TITLs are not transmitted.)
	:	:
	0ddddd ddn	title-n
EOX	11110111 F7	End Of Exclusive

If 01V receives a bulk request for an empty memory, TITLs are not transmitted.

function	number	
0x30 scene title	0-99(mem 0-99),0x7f(edit buffer)	for response
	1-99(mem 1-99),0x7f(edit buffer)	for Rx
0x31 eq lib title	0-79(library 1-80)	for response
	40-79(library 41-80)	for Rx
0x32 dynamics lib title	0-79(library 1-80)	for response
	40-79(library 41-80)	for Rx
0x33 eff lib title	0-98(library 1-99)	for response
	42-98(library 43-99)	for Rx

**PARAMETER VALUE REQUEST (type 0x02:function call(title))**

**Reception**

When [Parameter Change RX] is ON and the [Rx CH] matches the Device Channel included in the SUB STATUS, this message will be received.

When [Parameter Change ECHO] is ON and the 01V itself did not receive the message, the message will be echoed.

When this is received, the title of the corresponding memory/library will be transmitted.

**Transmission**

When [Parameter Change ECHO] is ON and the 01V itself did not receive the message, the message will be echoed.

STATUS	11110000 F0	System Exclusive Message
ID No.	01000011 43	Manufacturer's ID No.(YAMAHA)
SUB STATUS	0011nnnn 3n	parameter request n=0-15(Device Channel No.1-16)
GROUP ID	00111110 3e	MODEL ID
MODEL ID	00000100 04	Device code (01V)
PARAM TYPE	00000010 02	function call
DATA	0ddddd dd0	function
	0ddddd dd1	number
EOX	11110111 F7	End Of Exclusive

function	number	
0x30 scene title	0-99(mem 0-99),0x7f(edit buffer)	
0x31 eq lib title	0-79(library 1-80)	
0x32 dynamics lib title	0-79(library 1-80)	
0x33 eff lib title	0-98(library 1-99)	

**PARAMETER CHANGE (type operation for type 0x03:controller(LCD-Fader mode))**

**Reception**

When [Parameter Change RX] is ON and the [Rx CH] matches the Device Channel included in the SUB STATUS, the message will be received.

When [Parameter Change ECHO] is ON, this message will be echoed.

When this message is received, the LCD screen, the corresponding Fader Mode, and the specified channel will be selected.

STATUS	11110000	F0	System Exclusive Message
ID No.	01000011	43	Manufacturer's ID No.(YAMAHA)
SUB STATUS	0001nnnn	1n	parameter change n=0-15(Device Channel No.1-16)
GROUP ID	00111110	3e	MODEL ID
MODEL ID	00000100	04	Device code (01V)
PARAM TYPE	01000011	03	controller (type)
DATA	00000001	01	control No.(LCD-Fader mode)
	0ddddddd	dd	channel select(0-30)
	0ddddddd	dd	LCD select No.(0-17)
	0000dddd	dd	PAGE No.(0-4)
EOX	11110111	F7	End Of Exclusive

**PARAMETER CHANGE (bit operation for type 0x43:controller(key remote))**

**Reception**

When [Parameter Change RX] is ON and the [Rx CH] matches the Device Channel included in the SUB STATUS, this message will be received.

When [Parameter Change ECHO] is ON, this message will be echoed.

When this message is received, the same processing will be performed as when the specified key (refer to the table below) is pressed (released).

**Transmission**

When [Parameter Change ECHO] is ON, this message will be transmitted without change.

STATUS	11110000	F0	System Exclusive Message
ID No.	01000011	43	Manufacturer's ID No.(YAMAHA)
SUB STATUS	0001nnnn	1n	parameter change n=0-15(Device Channel No.1-16)
GROUP ID	00111110	3e	MODEL ID
MODEL ID	00000100	04	Device code (01V)
PARAM TYPE	01000011	43	controller
DATA	00000000	00	control no.(0:key remote)
	0ddddddd	dd	No. 0-10,99-102(key 1-11,100-103)
	0000dddd	dd	data(bit0-2:change bit no.0-7, bit3:0=reset 1=set)
	:	:	:
EOX	11110111	F7	End Of Exclusive

KEY	key no.	bit0	bit1	bit2	bit3	bit4	bit5	bit6	bit7
key1	0	ON1	ON2	ON3	ON4	ON5	ON6	ON7	ON8
key2	1	ON9	ON10	ON11	ON12	ON13-14	ON15-16	ONSTOUT	-----
key3	2	SOLO1	SOLO2	SOLO3	SOLO4	SOLO5	SOLO6	SOLO7	SOLO8
key4	3	SOLO9	SOLO10	SOLO11	SOLO12	SOLO13-14	SOLO15-16	-----	-----
key5	4	SEL1	SEL2	SEL3	SEL4	SEL5	SEL6	SEL7	SEL8
key6	5	SEL9	SEL10	SEL11	SEL12	SEL13-14	SEL15-16	SEL STO	-----
key7	6	ONRTN1	ONRTN2	SOLORT1	SOLORT2	SELRTN1	SELRTN2	HOME	MEMORY
key8	7	AUX1	AUX2	AUX3	AUX4	EFFECT1	EFFECT2	OPTION	REMOTTE
key9	8	LOW	L-MID	H-MID	HIGH	-----	-----	-----	-----
key10	9	UP	LEFT	RIGHT	DOWN	ENTER	INC	DEC	-----
key11	10	DYNAMIX EQ	DELAY	PAN	UTILITY	MIDI	SETUP	VIEW	-----
key100	99	FRZ-REC	FRZ-PLAY	-----	-----	-----	-----	-----	-----
key101	100	SOLO1	SOLO2	SOLO3	SOLO4	SOLO5	SOLO6	SOLO7	SOLO8
key102	101	SOLO9	SOLO10	SOLO11	SOLO12	SOLO13-14	SOLO15-16	SOLO-RTN1	SOLO-RTN2
key103	102	SOLO17	SOLO18	SOLO19	SOLO20	SOLO21	SOLO22	SOLO23	SOLO24

\* Normally, data should be transmitted as "set(bit3=1)." In this case, the 01V will determine that that switch has been pressed and then immediately released, and will perform the appropriate processing. This means that you will not have to transmit "reset(bit3=0)" separately.

\* The keys followed by 100 are virtual key, it would be the keys on LCD.

**PARAMETER CHANGE (type 0x04:multiple linking)**

This message is valid only for the connector that has been specified as the LINK PORT.

When two '01V' units have been connected by a cable, some of the functions (refer to the following table) will be linked.

The same LINK PORT connector settings must be made on both units.

**Reception**

This message is always received, and will execute the LINK function (refer to the following table). (This is not dependent on MIDI-SETUP.)

**Transmission**

This message is transmitted when LINK-related functions (refer to following table) are performed. (This is not dependent on MIDI-SETUP.)

When [Parameter Change ECHO] is ON, this message is transmitted without change.

STATUS	11110000	F0	System Exclusive Message
ID No.	01000011	43	Manufacturer's ID No.(YAMAHA)
SUB STATUS	0001nnnn	1n	n=0-15(Tx/Rx Channel No.1-16)
GROUP ID	00111110	3e	MODEL ID
MODEL ID	00000100	04	Device code (01V)
PARAM TYPE	00000100	04	multiple linking
DATA	0mmfffff	mf	data format (bit6-5:status, bit4-0:contents)
	0ddddddd	dd0	data #0
	0ddddddd	dd1	data #1
	:	:	:
EOX	11110111	F7	End Of Exclusive

Status	Function	Note
0x00	scene recall	Recall the specified memory number
0x01	scene store	Store to the specified memory number with title (Assign the same title to all)
0x02	scene title edit	If the title was modified, make it the same, make it match
0x48	solo mode bit6: enable/disable bit5: on/off bit2: recording/mixdown bit1: sel mix/last bit0: after fader/pre fader	Match the solo mode
0x60	display call	When the screen (Fader Mode) is changed, make it match
0x61	metering point	Make the meter points match
0x62	peak hold	Make the meter Peak Hold ON/OFF match

**PARAMETER CHANGE(type 0x05:remote meter)**

When the following request is received to enable transmission, the specified parameter data will be transmitted at 30 msec intervals for five seconds. If you want meter data to be transmitted continuously, you must continue transmitting requests less than five seconds apart.

**Reception**

When [Parameter Change RX] is ON and the [Rx CH] matches the Device Channel that is included in the SUB STATUS, this message is received.

When [LOCAL OFF] is ON, the incoming meter data will be displayed. In other cases it will be ignored.

**Transmission**

When transmission is enabled by a request, this will be transmitted every 30msec on the [Rx CH] channel, for five seconds.

Transmission will be disabled when the power is turned on, and when PORT settings have been modified.

STATUS	11110000	F0	System Exclusive Message
ID No.	01000011	43	Manufacturer's ID No.(YAMAHA)
SUB STATUS	0001nnnn	1n	n=0-15(Tx/Rx Channel No.1-16)
GROUOP ID	00111110	3e	MODEL ID
MODEL ID	00000100	04	Device code (01V)
PARAM TYPE	00000101	05	remote meter
DATA	0sgttttt	tt	meter no.(s:special bit, g:gr bit)
	0mmmmmm	mm0	
	0mmmmmm	mm1	
	:	:	
EOX	11110111	F7	End Of Exclusive

In the Meter no., bit 6 is the special bit, and bit 5 is the gr bit.

When the Gr bit is on, the single byte gr will be added uniformly to the end of the data string.

When the Special bit is on, the two bytes stLED L/R will be added uniformly to the end of the data string.

When both are on, gr comes first, and stLED L/R come later.

**PARAMETER VALUE REQUEST(type 0x05:remote meter)**

This message is used to obtain meter data from the 01V. It is used in LOCAL OFF MODE to display the meter of the remote device, or to display the meter on the screen of a personal computer, etc.

In order to obtain meter data, the meter whose data is required must be displayed in the LCD of the remote device. This means that before transmitting this request, you must first transmit the above-described "4.6.4.11 PARAMETER CHANGE (type 0x03:bit operation for controller(LCD-Fader mode))" to display the appropriate meter in the LCD screen of the remote device.

**Reception**

When [Parameter Change RX] is ON and the [Rx CH] matches the Device Channel included in SUB STATUS, this message will be received.

When this message is received, Parameter Change (remote meter) messages will begin to be transmitted on the [Rx CH] channel.

**Transmission**

When [LOCAL OFF] is ON, transmit a meter data request for the currently displayed meter on the [Tx CH]. For each request, meter data will be transmitted for five seconds. If you want meter data continuously for longer than this, you will need to transmit requests at intervals of five seconds or less. When the 01V is in LOCAL OFF MODE, transmit requests at approximately one-second intervals. When [Parameter Change ECHO] is ON and the 01V itself did not receive this message, the message will be echoed.

STATUS	11110000	F0	System Exclusive Message
ID No.	01000011	43	Manufacturer's ID No.(YAMAHA)
SUB STATUS	0011nnnn	3n	n=0-15(Tx/Rx Channel No.1-16)
GROUOP ID	00111110	3e	MODEL ID
MODEL ID	00000100	04	Device code (01V)
PARAM TYPE	00000101	05	remote meter
DATA	0sgttttt	tt	meter no.(s:special bit, g:gr bit)
EOX	11110111	F7	End Of Exclusive

Table of signal levels and codes

Level	code	Level	code	Level	code
-72dB	0x1F	-30dB	0x57	-9dB	0x72
-68dB	0x24	-27dB	0x5A	-8dB	0x73
-64dB	0x29	-24dB	0x5F	-7dB	0x75
-60dB	0x2F	-21dB	0x62	-6dB	0x77
-56dB	0x33	-18dB	0x67	-5dB	0x78
-51dB	0x3A	-16dB	0x69	-4dB	0x79
-48dB	0x3F	-15dB	0x6A	-3dB	0x7A
-46dB	0x41	-14dB	0x6B	-2dB	0x7B
-42dB	0x47	-13dB	0x6D	-1dB	0x7D
-39dB	0x4A	-12dB	0x6F	0dB	0x7E
-36dB	0x4F	-11dB	0x70	CLIP	0x7F
-33dB	0x52	-10dB	0x71		

**5. SYSTEM EXCLUSIVE MESSAGE (Bulk Dump) & REQUEST**

These messages input and output the contents of various types of internal memory.

The unique header identifies whether or not the data is for the 01V.

The CHECK SUM is calculated by adding the data following the BYTE COUNT(LOW) until the data preceding the CHECK SUM, then inverting the bits (2's complement), and setting bit 7 to 0.

CHECK SUM = ( -sum) & 0x7F

**Reception**

This is received if [Bulk RX] is ON and the [Rx CH] matches the Device Channel that is included in SUB STATUS.

When a BULK DUMP is received, it will immediately be written into the specified memory.

When a BULK DUMP REQUEST is received, a bulk dump will be transmitted immediately.

**Transmission**

In the [MIDI-BULK] page, this is transmitted on the [Tx CH] channel by key operations.

In response to a Bulk Dump Request, a Bulk Dump Message is transmitted on the [Rx CH] channel.

data name	rx/tx	function
'M'	rx/tx	Scene Memory & Request
'S'	rx/tx	Setup Memory & Request
'T'	rx/tx	Remote(Internal Parameter) Memory & Request
'L'	rx/tx	Remote(MMC) Memory & Request
'U'	rx/tx	Remote(User Define) Memory & Request
'C'	rx/tx	Control Change Assign Table & Request
'P'	rx/tx	Program Change Assign Table & Request
'Q'	rx/tx	Equalizer Library & Request
'Y'	rx/tx	Dynamics Library & Request
'E'	rx/tx	Effect Library & Request

**SCENE MEMORY BULK DUMP FORMAT**

```

STATUS          11110000 F0 System Exclusive Message
ID No.          01000011 43 Manufacturer's ID No.(YAMAHA)
SUB STATUS      0000nnnn 0n n=0-15(Device Channel No.1-16)
FORMAT No.      01111110 7E Universal Bulk Dump
BYTE COUNT(HIGH) 00010000 10 2048(2038+10)bytes
BYTE COUNT(LOW) 00001010 00
                01001100 4C 'L'
                01001101 4D 'M'
                00100000 20 ''
                00100000 20 ''
                00111000 38 '8'
                01000010 42 'B'
                00110011 33 '3'
                00110100 34 '4'
DATA NAME       01001101 4D 'M'
                0mmmmmmmm nm m=0-99,127(Scene Memory No.0-99,
                edit buffer)
                Receive is effective No.1-99,127
DATA            0ddddddd ds Scene Memory(10+(1014*2) bytes)
                :
                0ddddddd de
CHECK SUM       0eeeeeee ee ee=(INVERT('L'+M'+...+ds+...+de)+1)
                AND 7Fh
EOX             11110111 F7 End Of Exclusive
    
```

The ten bytes at the beginning are the ID + title, and are 7 bit data.  
The subsequent 1014 bytes are all split into 4 bit data.

**SCENE MEMORY BULK DUMP REQUEST FORMAT**

```

STATUS          11110000 F0 System Exclusive Message
ID No.          01000011 43 Manufacturer's ID (YAMAHA)
SUB STATUS      0010nnnn 2n n=0-15(Device Channel No.1-16)
FORMAT No.      01111110 7E Universal Bulk Dump
                01001100 4C 'L'
                01001101 4D 'M'
                00100000 20 ''
                00100000 20 ''
                00111000 38 '8'
                01000010 42 'B'
                00110011 33 '3'
                00110100 34 '4'
DATA NAME       01001101 4D 'M'
                0mmmmmmmm nm m=0-99,127(Scene Memory No.0-99,cur-
                rent)
EOX             11110111 F7 End Of Exclusive
    
```

**SETUP MEMORY BULK DUMP FORMAT**

```

STATUS          11110000 F0 System Exclusive Message
ID No.          01000011 43 Manufacturer's ID No.(YAMAHA)
SUB STATUS      0000nnnn 0n n=0-15(Device Channel No.1-16)
FORMAT No.      01111110 7E Universal Bulk Dump
BYTE COUNT(HIGH) 00000010 02 266(256+10)bytes
BYTE COUNT(LOW) 00001010 0A
                01001100 4C 'L'
                01001101 4D 'M'
                00100000 20 ''
                00100000 20 ''
                00111000 38 '8'
                01000010 42 'B'
                00110011 33 '3'
                00110100 34 '4'
DATA NAME       01010011 53 'S'
                00100000 20 ''
DATA            0ddddddd ds Setup Memory(128*2bytes)
                :
                0ddddddd de
CHECK SUM       0eeeeeee ee ee=(INVERT('L'+M'+...+ds+...+de)+1)
                AND 7Fh
EOX             11110111 F7 End Of Exclusive
    
```

All data is split into 4 bit.

**SETUP MEMORY BULK DUMP REQUEST FORMAT**

```

STATUS          11110000 F0 System Exclusive Message
ID No.          01000011 43 Manufacturer's ID (YAMAHA)
SUB STATUS      0010nnnn 2n n=0-15(Device Channel No.1-16)
FORMAT No.      01111110 7E Universal Bulk Dump
                01001100 4C 'L'
                01001101 4D 'M'
                00100000 20 ''
                00100000 20 ''
                00111000 38 '8'
                01000010 42 'B'
                00110011 33 '3'
                00110100 34 '4'
DATA NAME       01010011 53 'S'
                00100000 20 ''
EOX             11110111 F7 End Of Exclusive
    
```

**REMOTE(Internal Parameter) MEMORY BULK DUMP FORMAT**

```

STATUS          11110000 F0 System Exclusive Message
ID No.          01000011 43 Manufacturer's ID No.(YAMAHA)
SUB STATUS      0000nnnn 0n n=0-15(Device Channel No.1-16)
FORMAT No.      01111110 7E Universal Bulk Dump
BYTE COUNT(HIGH) 00000000 00 100(90+10)bytes
BYTE COUNT(LOW) 01100100 64
                01001100 4C 'L'
                01001101 4D 'M'
                00100000 20 ''
                00100000 20 ''
                00111000 38 '8'
                01000010 42 'B'
                00110011 33 '3'
                00110100 34 '4'
DATA NAME       01001001 49 T
                0bbbbbbb bb b = 0-3(bank no.1-4)
DATA            0ddddddd ds Remote(Internal Parameter) Mem-
                ory(90bytes)
                :
                0ddddddd de
CHECK SUM       0eeeeeee ee ee=(INVERT('L'+M'+...+ds+...+de)+1)
                AND 7Fh
EOX             11110111 F7 End Of Exclusive
    
```

All data is 7 bit data.

**REMOTE(Internal Parameter) MEMORY BULK DUMP REQUEST FORMAT**

```

STATUS          11110000 F0 System Exclusive Message
ID No.          01000011 43 Manufacturer's ID (YAMAHA)
SUB STATUS      0010nnnn 2n n=0-15(Device Channel No.1-16)
FORMAT No.      01111110 7E Universal Bulk Dump
                01001100 4C 'L'
                01001101 4D 'M'
                00100000 20 ''
                00100000 20 ''
                00111000 38 '8'
                01000010 42 'B'
                00110011 33 '3'
                00110100 34 '4'
DATA NAME       01001001 49 T
                0bbbbbbb bb b = 0-3(bank no.1-4)
EOX             11110111 F7 End Of Exclusive
    
```

**REMOTE(MMC) MEMORY BULK DUMP FORMAT**

STATUS	11110000	F0	System Exclusive Message
ID No.	01000011	43	Manufacturer's ID No.(YAMAHA)
SUB STATUS	0000nnnn	0n	n=0-15(Device Channel No.1-16)
FORMAT No.	01111110	7E	Universal Bulk Dump
BYTE COUNT(HIGH)	00000000	00	34(24+10)bytes
BYTE COUNT(LOW)	00100010	22	
	01001100	4C	'L'
	01001101	4D	'M'
	00100000	20	''
	00100000	20	''
	00111000	38	'8'
	01000010	42	'B'
	00110011	33	'3'
	00110100	34	'4'
DATA NAME	01001100	4C	'L'
	00100000	20	''
DATA	0ddddd	ds	Remote(MMC) Memory(24bytes)
	:	:	
	0ddddd	de	
CHECK SUM	0eeeeeee	ee	ee=(INVERT('L'+M'+...+ds+...+de)+1) AND 7Fh
EOX	11110111	F7	End Of Exclusive

All data is 7 bit data.

**REMOTE(MMC) MEMORY BULK DUMP REQUEST FORMAT**

STATUS	11110000	F0	System Exclusive Message
ID No.	01000011	43	Manufacturer's ID (YAMAHA)
SUB STATUS	0010nnnn	2n	n=0-15(Device Channel No.1-16)
FORMAT No.	01111110	7E	Universal Bulk Dump
	01001100	4C	'L'
	01001101	4D	'M'
	00100000	20	''
	00100000	20	''
	00111000	38	'8'
	01000010	42	'B'
	00110011	33	'3'
	00110100	34	'4'
DATA NAME	01001100	4C	'L'
	00100000	20	''
EOX	11110111	F7	End Of Exclusive

**REMOTE(User Define) MEMORY BULK DUMP FORMAT**

STATUS	11110000	F0	System Exclusive Message
ID No.	01000011	43	Manufacturer's ID No.(YAMAHA)
SUB STATUS	0000nnnn	0n	n=0-15(Device Channel No.1-16)
FORMAT No.	01111110	7E	Universal Bulk Dump
BYTE COUNT(HIGH)	00001011	0B	1450(1440+10)bytes
BYTE COUNT(LOW)	00101010	2A	
	01001100	4C	'L'
	01001101	4D	'M'
	00100000	20	''
	00100000	20	''
	00111000	38	'8'
	01000010	42	'B'
	00110011	33	'3'
	00110100	34	'4'
DATA NAME	01010101	55	'U'
	0bbbbbbb	bb	bb = 0-3(bank no. 1-4)
DATA	0ddddd	ds	Remote(User Define) Memory(1440bytes)
	:	:	
	0ddddd	de	
CHECK SUM	0eeeeeee	ee	ee=(INVERT('L'+M'+...+ds+...+de)+1) AND 7Fh
EOX	11110111	F7	End Of Exclusive

All data (word) is split into 7 bit.

**REMOTE(User Define) MEMORY BULK DUMP REQUEST FORMAT**

STATUS	11110000	F0	System Exclusive Message
ID No.	01000011	43	Manufacturer's ID (YAMAHA)
SUB STATUS	0010nnnn	2n	n=0-15(Device Channel No.1-16)
FORMAT No.	01111110	7E	Universal Bulk Dump
	01001100	4C	'L'
	01001101	4D	'M'
	00100000	20	''
	00100000	20	''
	00111000	38	'8'
	01000010	42	'B'
	00110011	33	'3'
	00110100	34	'4'
DATA NAME	01010101	55	'U'
	0bbbbbbb	bb	bb = 0-3(bank no. 1-4)
EOX	11110111	F7	End Of Exclusive

**EQUALIZER LIBRARY BULK DUMP FORMAT**

STATUS	11110000	F0	System Exclusive Message
ID No.	01000011	43	Manufacturer's ID No.(YAMAHA)
SUB STATUS	0000nnnn	0n	n=0-15(Device Channel No.1-16)
FORMAT No.	01111110	7E	Universal Bulk Dump
BYTE COUNT(HIGH)	00000000	00	46(36+10)bytes
BYTE COUNT(LOW)	00101110	2E	
	01001100	4C	'L'
	01001101	4D	'M'
	00100000	20	''
	00100000	20	''
	00111000	38	'8'
	01000010	42	'B'
	00110011	33	'3'
	00110100	34	'4'
DATA NAME	01010001	51	'Q'
	0mmmmmm	mm	m= 0-79 (Equalizer Library No.1-80) 96-124(ch1-12,13/14,15/16,RTN1/2,AUX 1-4,ST MAS,ch17-24) Receive is effective No.40-79,96-125 Equalizer Library Mem- ory(12+(12*2)bytes)
DATA	0ddddd	ds	
	:	:	
	0ddddd	de	
CHECK SUM	0eeeeeee	ee	ee=(INVERT('L'+M'+...+ds+...+de)+1) AND 7Fh
EOX	11110111	F7	End Of Exclusive

The twelve bytes at the beginning are the title, and are 7 bit data. The following twelve bytes are all split into 4 bit data.

**EQUALIZER LIBRARY BULK DUMP REQUEST FORMAT**

STATUS	11110000	F0	System Exclusive Message
ID No.	01000011	43	Manufacturer's ID (YAMAHA)
SUB STATUS	0010nnnn	2n	n=0-15(Device Channel No.1-16)
FORMAT No.	01111110	7E	Universal Bulk Dump
	01001100	4C	'L'
	01001101	4D	'M'
	00100000	20	''
	00100000	20	''
	00111000	38	'8'
	01000010	42	'B'
	00110011	33	'3'
	00110100	34	'4'
DATA NAME	01010001	51	'Q'
	0mmmmmm	mm	m= 0-79 (Equalizer Library No.1-80) 96-124(ch1-12,13/14,15/16,RTN1/2,AUX 1-4,ST MAS,ch17-24)
EOX	11110111	F7	End Of Exclusive

**DYNAMICS LIBRARY BULK DUMP FORMAT**

```

STATUS          11110000 F0 System Exclusive Message
ID No.          01000011 43 Manufacturer's ID No.(YAMAHA)
SUB STATUS      0000nnnn 0n n=0-15(Device Channel No.1-16)
FORMAT No.      01111110 7E Universal Bulk Dump
BYTE COUNT(HIGH) 00000000 00 36(26+10)bytes
BYTE COUNT(LOW) 00100100 24
                01001100 4C 'L'
                01001101 4D 'M'
                00100000 20 ''
                00100000 20 ''
                00111000 38 '8'
                01000010 42 'B'
                00110011 33 '3'
                00110100 34 '4'
                01011001 59 'Y'
DATA NAME       01011001 59 'Y'
                0mmmmmmmm mm m= 0-79 (Dynamics Library No.1-80)
                96-114(ch1-12,13/14,15/16,AUX1-4,ST
                MAS)
                Receive is effective No.40-79,96-115
DATA            0ddddd ds Dynamics Library Mem-
                : : ory(12+(7*2)bytes)
                0ddddd de
CHECK SUM       0eeeee ee ee=(INVERT('L'+ 'M'+...+ds+...+de)+1)
                AND 7Fh
EOX             11110111 F7 End Of Exclusive
    
```

The first twelve bytes are the title, and are 7 bit data. The following seven bytes are all split into 4 bit data.

**DYNAMICS LIBRARY BULK DUMP REQUEST FORMAT**

```

STATUS          11110000 F0 System Exclusive Message
ID No.          01000011 43 Manufacturer's ID (YAMAHA)
SUB STATUS      0010nnnn 2n n=0-15(Device Channel No.1-16)
FORMAT No.      01111110 7E Universal Bulk Dump
                01001100 4C 'L'
                01001101 4D 'M'
                00100000 20 ''
                00100000 20 ''
                00111000 38 '8'
                01000010 42 'B'
                00110011 33 '3'
                00110100 34 '4'
                01011001 59 'Y'
DATA NAME       01011001 59 'Y'
                0mmmmmmmm mm m= 0-79 (Dynamics Library No.1-80)
                96-114(ch1-12,13/14,15/16,AUX1-4,ST
                MAS)
EOX             11110111 F7 End Of Exclusive
    
```

**EFFECT LIBRARY BULK DUMP FORMAT**

```

STATUS          11110000 F0 System Exclusive Message
ID No.          01000011 43 Manufacturer's ID No.(YAMAHA)
SUB STATUS      0000nnnn 0n n=0-15(Device Channel No.1-16)
FORMAT No.      01111110 7E Universal Bulk Dump
BYTE COUNT(HIGH) 00000000 00 104(94+10)bytes
BYTE COUNT(LOW) 01101000 68
                01001100 4C 'L'
                01001101 4D 'M'
                00100000 20 ''
                00100000 20 ''
                00111000 38 '8'
                01000010 42 'B'
                00110011 33 '3'
                00110100 34 '4'
                01000101 45 'E'
DATA NAME       01000101 45 'E'
                0mmmmmmmm mm m= 0-98 (Effect Library No.1-99)
                112-113(Effect1, Effect2)
                Receive is effective 42-98,112-113
DATA            0ddddd ds Effect Library Memory(12+(41*2)bytes)
                : :
                0ddddd de
CHECK SUM       0eeeee ee ee=(INVERT('L'+ 'M'+...+ds+...+de)+1)
                AND 7Fh
EOX             11110111 F7 End Of Exclusive
    
```

The first twelve bytes are the title, and are 7 bit data. The following 41 bytes are all split into 4 bit data.

**EFFECT LIBRARY BULK DUMP REQUEST FORMAT**

```

STATUS          11110000 F0 System Exclusive Message
ID No.          01000011 43 Manufacturer's ID (YAMAHA)
SUB STATUS      0010nnnn 2n n=0-15(Device Channel No.1-16)
FORMAT No.      01111110 7E Universal Bulk Dump
                01001100 4C 'L'
                01001101 4D 'M'
                00100000 20 ''
                00100000 20 ''
                00111000 38 '8'
                01000010 42 'B'
                00110011 33 '3'
                00110100 34 '4'
                01000101 45 'E'
DATA NAME       01000101 45 'E'
                0mmmmmmmm mm m= 0-98 (Effect Library No.1-99)
                112-113(Effect1, Effect2)
EOX             11110111 F7 End Of Exclusive
    
```

**PROGRAM CHANGE ASSIGNMENT TABLE BULK DUMP FORMAT**

```

STATUS          11110000 F0 System Exclusive Message
ID No.          01000011 43 Manufacturer's ID No.(YAMAHA)
SUB STATUS      0000nnnn 0n n=0-15(Device Channel No.1-16)
FORMAT No.      01111110 7E Universal Bulk Dump
BYTE COUNT(HIGH) 00000001 01 138(128+10)bytes
BYTE COUNT(LOW) 00001010 0A
                01001100 4C 'L'
                01001101 4D 'M'
                00100000 20 ''
                00100000 20 ''
                00111000 38 '8'
                01000010 42 'B'
                00110011 33 '3'
                00110100 34 '4'
DATA NAME       01010000 50 'P'
                00100000 20 ''
DATA            0ddddd ds Program Change Table(128bytes)
                : :
                0ddddd de
CHECK SUM       0eeeeeee ee ee=(INVERT('L'+ 'M'+...+ds+...+de)+1)
                AND 7Fh
EOX            11110111 F7 End Of Exclusive

```

All data is 7 bit data.

**PROGRAM CHANGE ASSIGNMENT TABLE BULK DUMP REQUEST FORMAT**

```

STATUS          11110000 F0 System Exclusive Message
ID No.          01000011 43 Manufacturer's ID (YAMAHA)
SUB STATUS      0010nnnn 2n n=0-15(Device Channel No.1-16)
FORMAT No.      01111110 7E Universal Bulk Dump
                01001100 4C 'L'
                01001101 4D 'M'
                00100000 20 ''
                00100000 20 ''
                00111000 38 '8'
                01000010 42 'B'
                00110011 33 '3'
                00110100 34 '4'
DATA NAME       01010000 50 'P'
                00100000 20 ''
EOX            11110111 F7 End Of Exclusive

```

**Control Change Assignment Table Bulk Dump Format**

```

STATUS          11110000 F0 System Exclusive Message
ID No.          01000011 43 Manufacturer's ID No.(YAMAHA)
SUB STATUS      0000nnnn 0n n=0-15(Device Channel No.1-16)
FORMAT No.      01111110 7E Universal Bulk Dump
BYTE COUNT(HIGH) 00000010 02 352(342+10)bytes
BYTE COUNT(LOW) 01100000 60
                01001100 4C 'L'
                01001101 4D 'M'
                00100000 20 ''
                00100000 20 ''
                00111000 38 '8'
                01000010 42 'B'
                00110011 33 '3'
                00110100 34 '4'
DATA NAME       01000011 43 'C'
                00100000 20 ''
DATA            0ddddd ds Control Change Table(114x3bytes)
                : :
                0ddddd de
CHECK SUM       0eeeeeee ee ee=(INVERT('L'+ 'M'+...+ds+...+de)+1)
                AND 7Fh
EOX            11110111 F7 End Of Exclusive

```

All data is 7 bit data.

**CONTROL CHANGE ASSIGNMENT TABLE BULK DUMP REQUEST FORMAT**

```

STATUS          11110000 F0 System Exclusive Message
ID No.          01000011 43 Manufacturer's ID (YAMAHA)
SUB STATUS      0010nnnn 2n n=0-15(Device Channel No.1-16)
FORMAT No.      01111110 7E Universal Bulk Dump
                01001100 4C 'L'
                01001101 4D 'M'
                00100000 20 ''
                00100000 20 ''
                00111000 38 '8'
                01000010 42 'B'
                00110011 33 '3'
                00110100 34 '4'
DATA NAME       01000011 43 'C'
                00100000 20 ''
EOX            11110111 F7 End Of Exclusive

```



MIDI Implementation Chart

Function...		Transmitted	Recognized	Remarks
Basic Channel	Default Changed	1-16 1-16	1-16 1-16	Memorized
Mode	Default Messages Altered	X X *****	OMNI off/OMNI on X X	Memorized
Note Number	True Voice	X *****	0-127 X	
Velocity	Note On Note Off	X X	O O	
After Touch	Keys Ch's	X X	X X	
Pitch bend		X	X	
Control Change	0-95, 102-119	O	O	Assignable
Prog Change	:True#	0-127 *****	0-127 0-99	Assignable
System Exclusive		O	O	*1
System Common	:Song Pos :Song Sel :Tune	X X X	X X X	
System Real Time	:Clock :Commands	X X	X X	
Aux Messages	:Local ON/OFF :All Notes OFF :Active Sense :Reset	X X X X	X X O O	
Notes	MTC quarter frame message is recognized *1: Bulk Dump/Request, Parameter Change/Request, and MMC. For MIDI Remote, ALL messages can be transmitted.			

Mode 1: OMNI ON, POLY  
Mode 3: OMNI OFF, POLY

Mode 2: OMNI ON, MONO  
Mode 4: OMNI OFF, MONO

O: Yes  
X: No

---

# Appendix D: Resources

---

## Books

- *Introducing Digital Audio*, Ian R Sinclair, second edition, PC Publishing, 1992. A good all-around introduction to digital audio. Second edition explains oversampling and bitstream techniques.
- *Principles of Digital Audio*, Ken C. Pohlmann, Howard W.Sams & Co, 1989. Covering all aspects of digital audio, this book is ideal for newcomers who want to know the basics plus a bit more.
- *The Art of digital Audio*, John Watkinson, Focal Press (Butterworth Group), 1990. An essential read for digital audio professionals—but only for the serious!
- *The MIDI Ins, Outs & Thrus*, Jeff Rona, Hal Leonard Publishing, 1992. An excellent introduction to MIDI with many illustrations for easy understanding.
- *MIDI Systems & Control*, Francis Rumsey, second edition, Focal Press, 1994. Covers all MIDI topics in detail and looks at how MIDI can be used to control systems (i.e., digital mixers, synths).
- *THE MIDI BOOK*, Steve DeFuria with Joe Scacciaferro, Hal Leonard Books. A good introduction for anyone new to MIDI.
- *THE MIDI RESOURCE BOOK*, Steve DeFuria with Joe Scacciaferro, Hal Leonard Books, 1988. Following on from THE MIDI BOOK, this one looks at the real nuts and bolts of MIDI including the MIDI specification and how to read MIDI Implementation Charts.
- *Yamaha Sound Reinforcement Handbook*, Gary Davis and Ralph Jones, second edition, Hal Leonard Publishing Corporation, 1990. Although primarily concerned with sound reinforcement, many of the subjects covered also apply to studio audio applications. The second edition also includes a comprehensive section on MIDI.

## Yamaha Web Site

Information on Yamaha professional audio products can be found at the Yamaha Professional Audio Web site.

<<http://www.yamaha.co.jp/product/proaudio/homeenglish/>>

---

# Glossary

---

**A/D converter**—An electronic device for converting analog signals to digital signals.

**AFL (After Fader Listen)**—Monitoring signals after the channel fader. *Contrast with PFL.*

**Aliasing**—A type of signal distortion that occurs during A/D conversion if the sampling rate is less than twice that of the highest audio frequency. A/D converters employ aliasing filters to remove audio frequencies higher than half the sampling rate. *See also Nyquist Sampling Theorem.*

**Anti-aliasing**—In digital audio, a technique used to prevent aliasing in the form of an anti-aliasing filter before A/D conversion. This filter removes audio frequencies that are higher than half the sampling frequency (e.g., for a 32 kHz sampling rate, audio frequencies above 16 kHz are filtered).

**Balancing**—A technique for reducing interference in audio cables by using two conductors, known as the hot (+) and cold (–), to carry two versions of the audio signal, 180 degrees out of phase with each other. Since any interference picked up will be in the same phase on both conductors, the differential amplifier at the balanced input cancels out the noise, but amplifies the audio signal.

**Bulk Dump**—A MIDI function for transferring data between MIDI equipment. Data is transmitted as MIDI System Exclusive messages.

**Bus**—A common conductor used to collect and distribute audio signals.

**Cascade**—A technique for increasing the number of available inputs by connecting two or more audio mixers together.

**CH**—Abbreviation for channel.

**Clipping**—The unwanted distortion effect caused by inputting too large a signal to an audio circuit.

**Coaxial**—The electrical connection for transmitting and receiving consumer format digital audio, typically using phono connectors. *See also Consumer format.*

**Consumer format**—The consumer digital audio format, developed by Sony and Philips, for transferring digital audio data between consumer-type digital audio equipment, such as CD players, DAT, DCC, and MiniDisc decks. Two channels of digital audio (left & right) are carried in one connection, usually a phono connection. This format is also referred to as IEC60958 (formerly 958) and S/PDIF. *See also Coaxial.*

**Control Change**—A type of MIDI message providing real-time parameter control. Typical Control Changes include Modulation, Volume, Pan, and Portamento.

**D/A converter**—An electronic device for converting digital signals to analog signals.

**De-emphasis**—*See Emphasis.*

**DIO**—Abbreviation for digital input and output.

**Dither**—The process of adding low-level random noise to audio signals in order to reduce A/D converter quantization noise. Dither techniques are also used for digital audio wordlength reduction (e.g., 20 to 16-bit conversion).

**DSP (Digital Signal Processor)**—A chip designed specifically for processing large amounts of data at high speed and in real time. This type of processor is ideal for handling digital audio data.

**Dynamic range**—The difference between the loudest and quietest signal levels in a system. In an audio device, usually the difference between the maximum output level and the residual noise floor. In a digital system, the available dynamic range is deter-

mined by the data resolution, about 6 dB per digital bit. Hence, a 16-bit system theoretically provides a 96 dB dynamic range.

**Edit buffer**—The memory area used to store the current mix settings. When a mix scene is stored, the Edit Buffer data is stored to the selected scene memory. When a mix scene is recalled, the data of the selected scene memory is copied into the Edit Buffer.

**EFF**—Abbreviation for effect.

**Emphasis**—A technique used to improve the noise performance of first generation AD/DA converters by boosting analog signals above 3.5 kHz by 6 dB/octave prior to A/D conversion. Emphasis was subsequently detected by the D/A converter and de-emphasis applied after D/A conversion. Although not used anymore, emphasis functions are often provided for compatibility with old digital recordings.

**EQ snapshot**—A set of EQ settings.

**Fade time**—The time it takes faders to move to new positions when a mix scene is recalled. Can be used for crossfading between channels.

**Fs**—Abbreviation for sampling frequency.

**General MIDI (GM)**—An extension to the MIDI Standard that, among other things, states that a General MIDI tone generator must be at least 24-note polyphonic, have 16 parts, and 128 specific preset voices.

**GR**—Abbreviation for gain reduction.

**Initial settings**—The settings used when a device is first turned on after leaving the factory. Also known as the default, or factory settings.

**LCD (Liquid Crystal Display)**—A type of display device that uses liquid crystals to generate characters and graphics.

**LED (Light Emitting Diode)**—A type of diode that lights up when an electric current is applied.

**Line-Level Signal**—A high-level signal in the range from  $-20$  dB to  $+20$  dB. Most audio equipment outputs signals at line level. *Contrast with* Low-Level Signal.

**Low-Level Signal**—A signal in the range from  $-100$  dB to  $-20$  dB. Microphone and electric guitar signals are in this range. *Contrast with* Line-Level Signal.

**LSB (Least Significant Byte)**—The byte of a digital word that represents the lowest value. *Contrast with* MSB.

**MIDI (Musical Instrument Digital Interface)**—An internationally agreed standard that allows electronic musical instruments and audio equipment to communicate.

**MIDI Device Number**—A numbering scheme used to identify individual devices in a MIDI system, commonly used for transmitting System Exclusive data.

**Mix scene**—A set of mixer settings. Just like a play, a piece of music consists of various scenes, each requiring different mixer settings. Mix scenes are stored in scene memories, and can be recalled manually or using MIDI Program Changes, which can be sent from a computer, MIDI footswitch, keyboard, or sequencer. *See also* Scene memories.

**MMC (MIDI Machine Control)**—A set of MIDI messages for controlling recorders, video tape machines, and other studio equipment. Typical MMC commands include Stop, Play, Rewind, and Pause.

**Modulation**—A technique for controlling a signal's frequency (pitch) or amplitude (level) using an LFO (low frequency oscillator). The LFO frequency is set using modulation speed parameters and the amount of LFO control is set using modulation depth parameters.

**MSB (Most Significant Byte)**—The byte of a digital word that represents the highest value. *Contrast with* LSB

**Noise gate**—An electronic switch that opens if the trigger signal falls below a specified threshold and closes if the trigger signal exceeds the threshold. Typically used to shut off unwanted hiss and noise.

**Nominal level**—*See* Operating Level.

**Nyquist theorem**—The Nyquist theorem states that the sampling rate of a digital audio system must be at least twice that of the highest audio frequency, otherwise waveform distortion known as aliasing will occur. *See also* Aliasing.

**OMNI**—The MIDI mode in which a device responds to MIDI data on all 16 channels.

**Operating level**—This is the signal level at which a piece of audio equipment is designed to operate. The two most common operating levels are  $-10$  dBV (316 mV), which is used by semiprofessional equipment, and  $+4$  dBu (1.23 V), which is used by professional equipment.

**Oversampling**—Sampling an audio signal at a rate higher than the actual sampling rate to reduce noise caused by quantization errors.

**PAM (Pulse Amplitude Modulation)**—In the first part of the A/D conversion process, pulses occurring at the sampling rate are modulated by an analog audio signal. *See also* PCM.

**PC**—Originally, the abbreviation for personal computer. Although today it's used as the generic name for any IBM-compatible personal computer, usually running a version of the Microsoft Windows operating system.

**PCM (Pulse Code Modulation)**—In the second part of the A/D conversion process, the pulses derived using PAM are converted into binary data words using PCM. *See also* PAM.

**Peaking**—A type of EQ circuit used to cut and boost a band of frequencies, producing a mountain-peak type response. The width of the band is called the Q. Midband EQ is usually of the peaking type. *Compare with* Shelving.

**PEQ**—An abbreviation for parametric EQ.

**PFL (Pre Fader Listen)**—Monitoring signals before the channel fader. *Contrast with* AFL.

**Phantom powering**—The technique for supplying condenser-type microphones a DC voltage via the signal carrying conductors of a balanced cable.

**Pink noise**—A type of random noise that contains an equal amount of energy per octave. For example, the bands 100–200, 800–1600, and 3000–6000 all contain the same amount of energy. White noise, on the other hand, has an equal amount of energy per frequency band. That is, 100–200, 800–900, and 3000–3100.

**Post fader**—The point in the signal path after the fader. Aux sends are often configured as post-fader sends, which means the aux send signal is sourced after the channel fader. The advantage of this is that the aux send signal can be controlled at the same time as the main channel signal using the same fader. Post-fader aux sends are typically used to feed effects processors. *See also* AFL.

**Pre fader**—The point in the signal path before the fader. Aux sends are often configured as pre-fader sends, which means the aux send signal is sourced before the channel fader. The advantage of this is that the aux send signal can be controlled independently of the main channel signal. Pre-fader aux sends are often used for foldback mixes. *See also* PFL.

**Program Change**—A type of MIDI message for selecting programs.

**Q**—The unit used to express a filter's selectivity. High values imply a narrow frequency band, low values, a wide frequency band.

**Quantization**—The PCM process in which PAM pulses are approximated to the nearest binary value available.

**S/PDIF format**—*See* Coaxial format.

**Sampling rate** — The number of times per second analog audio signals are sampled (i.e., measured) during A/D conversion. Common digital audio sampling rates are 32 kHz, 44.1 kHz, and 48 kHz.

**Scene memories**—Memory locations used to store mix scenes. *See also* Mix scene.

**Shelving**—A type of EQ circuit used to cut and boost frequencies above or below a set frequency. It produces a shelf-looking response curve. High and low EQs are usually of the shelving type. *Contrast with* Peaking.

**Signal-to-noise ratio (S/N)**—In an audio system, the difference between the operating signal level and the residual noise floor expressed as a decibel ratio, commonly used to measure a system's noise performance.

**Snapshot**—*See* Mix scene.

**ST OUT**—The 01V stereo output.

**System Exclusive**—A type of MIDI message for exclusive use with a particular device. *See also* Bulk Dump.

**THD (Total Harmonic Distortion)**—The measure of distortion introduced by an audio system relative to the audio signal expressed as a percentage. Compared to third-harmonic distortion, which is the measure of a single harmonic, total harmonic distortion is the sum of distortions produced at all harmonics.

**Unity gain**—A gain of one.

**Wordclock**—A clock signal used to synchronize the data processing circuits of all devices connected in a digital audio system. The wordclock frequency is the same as the sampling rate.

# Index

## Symbols

+48 V phantom powering 41

## Numerics

01V

- benefits 4
- cascading 214
- dimensions 271
- features 3
- initializing 204
- level diagram 257
- preferences 203
- rack mounting 259
- sonic performance 5

03D parameter to control change  
assignment table 277

-1/DEC & +1/INC buttons 31

15/16-2TR IN switch

- 2TR IN 77
- about 15
- input channels 40

2TR IN

- about 21
- using 77

2TR OUT

- about 21
- using 88

44.1 kHz sampling rate 209

## A

A/D converter, definition 293

About

- aux sends 94
- bus outs 108
- dynamics library 173
- dynamics processors 162
- edit buffer 185
- effects 120
- effects library 132
- EQ 62
- EQ library 67
- input channels 40
- interface 28
- MIDI & the 01V 222
- monitor & solo 76
- omni outs 116

option I/O cards 216

scene memories 184

stereo output 88

wordclocks 206

AFL, definition 293

AFL/PFL

- monitoring 78

- solo 80

Aliasing, definition 293

AMP SIMULATE 147

Analog controls 15

Analog input specifications 268

Analog output specifications 268

Anti-aliasing, definition 293

Assigning

- faders & on buttons 194

- input channels 49

- omni outs 116

- option I/O digital outputs 219

- oscillator 202

Attenuator 43

Auto navigate, wordclock source  
209

AUTOPAN 144

AUX page 1 95, 96, 97, 99, 100

AUX page 2 102

Aux pan page 102

Aux pre/post page 95, 96, 97, 99,  
100

Aux sends

- about 94

- block diagram 104

- dynamics processors 164

- effects returns 131

- EQ 64

- input channels 50

- level setting 99

- metering 83

- monitoring 94

- muting 100

- omni outs 94

- option I/O 94

- pairing 101

- panning 102

- pre/post fader 97

- specifications 265

- stereo pair block diagram 105

- using 95

- viewing settings 98

## B

Balancing the stereo output 90

Balancing, definition 293

Banks

- internal parameters 194

- MIDI bulk dump 232

- user define 238

Benefits of a Digital Mixer 4

Block diagrams

- aux sends 104

- aux stereo pair 105

- bus outs 112

- bus outs stereo pair 113

- complete 24

- effects 159

- input channels 60

- monitoring 79

- omni outs 118

- option I/O 220

- paired input channels 54

- solo 82

- stereo output 92

Books 291

Boosting the EQ 63

Bulk dump

- definition 293

- interval time 232

- setup 226

- using 232, 233

burst pink noise 202

Bus master page 109, 110

Bus outs

- about 108

- block diagram 112

- bus to stereo 110

- level setting 109

- metering 83

- monitoring 108

- muting 109

- omni outs 108

- option I/O 108

- pairing 111

- specifications 265

- stereo pair block diagram 113

Bus, definition 293

Bypassing the EQ 66

## C

Calibrating the faders 204

Cans. *See* PHONES

Cascade delay 215

Cascade, definition 293

- Cascading the 01V 214
  - CH copy page 59
  - CH, definition 293
  - CH13-14 flip page 213
  - CHORUS 142
  - Clipping, definition 293
  - Coaxial
    - definition 293
  - Coaxial digital input. *See* Digital stereo input
  - Coaxial digital output. *See* Digital stereo output
  - Comp 167
  - Compander 171
  - Configuration, summary 4
  - Connectors
    - 2TR IN 21
    - 2TR OUT 21
    - DIGITAL STEREO IN 23
    - DIGITAL STEREO OUT 23
    - INPUT (BAL) 1–12 20
    - INPUT (BAL) 13–16 20
    - MIDI 23
    - MONITOR OUT 22
    - OMNI OUT 22
    - PHONES 21
    - STEREO OUT 23
    - TO HOST 23
  - Consumer format
    - definition 293
  - Contrast control 16
  - Control change
    - 01V parameter assignment table 274
    - 03D parameter assignment table 277
    - control change assignments 229
    - definition 293
    - echo 225
    - MIDI bulk dump 232
    - omni 225
    - on/off 225
    - page 229
    - parameter control 229
    - programmable mixer 01
      - parameter assignment table 277
    - using 230
  - Control I/O specifications 270
  - Control page, option I/O 43, 47, 49, 58, 63, 95, 97, 123, 126
  - Controls
    - 1/DEC & +1/INC buttons 31
    - 15/16–2TR IN switch 15
    - contrast 16
    - CURSOR buttons 31
    - ENTER button 31
    - fader mode buttons 17
    - faders 19
    - function buttons 17
    - GAIN control 15
    - MONITOR OUT LEVEL control 15
    - MONITOR–2TR IN switch 15
    - ON buttons 18
    - PAD switch 15
    - PARAMETER wheel 31
    - PHONES LEVEL control 15
    - POWER switch 23
    - Return controls 19
    - SEL buttons 18
    - SELECTED CHANNEL 16
    - SOLO status indicator 19
  - Copying channel settings 59
  - Crossfading mix scenes 191
  - CURSOR buttons 31
  - Cutting the EQ 63
- D**
- D switch, routing 49
  - D/A converter, definition 293
  - DEC button 31
  - De-emphasis
    - digital stereo input 213
    - option I/O input 216
  - Delay
    - cascade compensation 215
    - effects parameter 137
    - input channels 45
    - omni outs 117
    - stereo output 91
  - DELAY LCR 141
  - Delay page 45
  - DELAY page 1 42
  - DELAY page 2 45
  - DELAY page 3 45
  - DELAY page 4 91, 117
  - DELAY UNITS, preference 203
  - DELAY+ER 152
  - DELAY+REV 154
  - DELAY->ER 153
  - DELAY->REV 155
  - Depth, 01V dimensions 271
  - Device number, MMC 236
  - DIGITAL IN SYNC CAUTION, preference 203
  - Digital input specifications 269
  - Digital mixer benefits 4
  - Digital output specifications 269
  - DIGITAL STEREO IN 23
  - Digital stereo input
    - connector 23
    - emphasis 213
    - specifications 264
    - using 213
  - DIGITAL STEREO OUT 23
  - Digital stereo output
    - connector 23
    - dither 212
    - specifications 266
    - stereo output 88
    - using 211
  - Dimensions 271
  - DIO, definition 293
  - Display
    - about 16
    - contrast 16
    - effects returns area 29
    - elements 30
    - faders 30
    - function area 28
    - memory area 29
    - messages 258
    - page area 29
    - parameter boxes 30
    - rotary controls 30
    - selected channel area 29
    - switches 30
  - DIST->DELAY 156
  - DISTORTION 146
  - Dither 212
  - Dither page 212
  - Dither, definition 293
  - DSP, definition 293
  - DUAL PITCH 145
  - Ducking 169
  - DYNA.FILTER 147
  - DYNA.FLANGE 147
  - DYNA.PHASER 148
  - Dynamic range, definition 293
  - Dynamics edit page 164, 165, 166
  - Dynamics library
    - about 173
    - MIDI bulk dump 232
    - number of programs 266
    - page 174, 175, 176
    - preset program list 163
    - recalling programs 175



- storing programs 174
- summary 6
- titling 176
- DYNAMICS page 1 164, 165, 166
- DYNAMICS page 2 174, 175, 176
- Dynamics processors
  - about 162
  - aux sends 164
  - comp 167
  - compander 171
  - ducking 169
  - editing 166
  - expander 170
  - gate 168
  - input channels 164
  - library 173
  - parameters 177
  - stereo output 165
  - using 164

**E**

- EARLY REF 138
- ECHO 142
- Edit buffer 185
  - definition 294
- Edit indicator 185
- Editing
  - dynamics processors 166
  - effects 136
- EFF, definition 294
- EFFECT page 1 123, 124, 136, 137, 157
- EFFECT page 2 132, 133, 134, 135
- EFFECT page 3 125
- Effects
  - about 120
  - block diagram 159
  - edit page 123, 124, 136, 137, 157
  - editing 136
  - library 132
  - library page 132, 133, 134, 135
  - parameters 138
  - pre/post page 125
  - summary 6
  - using 123
- Effects library
  - about 132
  - MIDI bulk dump 232
  - number of programs 266
  - preset program list 121
  - recalling programs 134

- storing programs 133
- titling programs 135
- Effects returns
  - aux sends 131
  - EQ 64
  - level setting 131
  - metering 83
  - monitoring 131
  - muting 130
  - panning 47, 131
  - routing 49
  - specifications 264
  - viewing settings 130
- Effects returns area, display 29
- Effects sends
  - master level settings 128
  - metering 86
  - muting 129
  - pre/post fader 125
  - viewing settings 127
- Emphasis
  - definition 294
  - digital stereo input 213
  - option I/O 216
- ENTER button 31
- EQ
  - about 62
  - adjusting 63
  - aux sends 64
  - bypassing 66
  - effects returns 64
  - input channels 63
  - library 67
  - library page 67, 68, 69, 70
  - page 63, 64, 65
  - resetting 66
  - specifications 267
  - stereo output 65
  - summary 5
- EQ AUTO SCREEN, preference 203
- EQ library
  - about 67
  - MIDI bulk dump 232
  - number of programs 266
  - preset program list 67
  - preset program parameters 71
  - recalling programs 69
  - storing programs 68
  - titling programs 70
- EQ page 43
- EQ page 1 43, 63, 64, 65
- EQ page 2 67, 68, 69, 70
- Error messages 258

- Expander 170

**F**

- F control 63
- FAD, user define 238
- Fade time
  - definition 294
  - mix scenes 191
- Fader modes 32
- Faders
  - about 19
  - calibrating 204
  - display 30
  - fader modes 35
  - grouping 55
  - mode buttons 17
  - nominal indicator 30
  - reassigning 194
  - stereo output 90
  - summary 5
- FB gain parameter, input delay 45
- Features 3
- FLANGE 143
- FREEZE 157
- Freq, effects parameter 137
- Function area, display 28
- Function buttons 17
- Further reading 291

**G**

- G control 63
- GAIN control
  - about 15
  - using 41
- Gang, pan mode 48
- Gate 168
- GATE REVERB 139
- General MIDI
  - definition 294
- General specifications 261
- GR, definition 294
- Group page 55, 56
- Grouping faders 55
- Grouping mutes 56
- GUI interface
  - about 28
  - summary 6

**H**

Headphones. *See* PHONES  
 Height, 01V dimensions 271  
 HIGH button 63  
 HI-MID button 63  
 HOME page 1 83  
 HOME page 2 83  
 HOME page 3 84  
 HOME page 4 84  
 HOME page 5 85  
 Home page, Yamaha web site 291  
 HPF 62  
 HQ.PITCH 144

**I**

Implementation chart, MIDI 290  
 INC button 31  
 INC/DEC SCENE RECALL,  
   preference 203  
 Individual, pan mode 48  
 Initial settings, definition 294  
 Initializing  
   01V 204  
   internal parameter banks 194  
   parameter to control change  
     table 229  
   scene memory to program  
     change table 227  
   user defined MIDI controllers  
     238  
 INPUT (BAL) 1–12 20  
 INPUT (BAL) 13–16 20  
 Input channels  
   1 through 12 40  
   13 through 16 40  
   17 through 24 40  
   attenuator 43  
   aux sends 50  
   block diagram 60  
   copying settings 59  
   delay 45  
   dynamics processors 164  
   EQ 63  
   grouping faders 55  
   grouping mutes 56  
   level setting 46  
   metering 83  
   monitoring 50  
   muting 46  
   omni outs 50  
   option I/O 50  
   overview 40

  pairing 52  
   panning 47  
   phase 42  
   routing 49  
   specifications 263  
   swapping inputs 51  
   swapping settings 59  
   viewing settings 57  
 Input jacks 20  
 Input meter page 83  
 Input swap page 51  
 Inputs and outputs 20  
 Internal parameter page 194  
 Interval time, MIDI bulk dump 232  
 Inv gang, pan mode 48

**L**

Latch, user define 238  
 LCD, definition 294  
 LED, definition 294  
 Level diagram 257  
 Level setting  
   aux sends 99  
   bus outs 109  
   effects returns 131  
   effects send masters 128  
   input channels 46  
   stereo output 90  
 Libraries  
   dynamics 173  
   effects 132  
   EQ 67  
 LIBRARY LIST ORDER, preference  
   204  
 Line inputs 20  
 Line-level signal, definition 294  
 Link port  
   about 222  
   selecting 224  
   using 224  
 Linking 01Vs 239  
 LISTEN  
   monitoring 78  
   solo 80  
 Local control 234  
 Locate points  
   MMC 236  
 LO-MID button 63  
 LOW button 63  
 Low-level signal, definition 294  
 LPF 62  
 LSB, definition 294

**M**

Mains lead 11  
 Memory area, display 29  
 MEMORY page 1 186, 187, 189,  
   190  
 MEMORY page 2 191  
 MEMORY page 3 190  
 MEMORY page 4 192  
 Messages, display 258  
 Metering  
   aux sends 83  
   bus outs 83  
   effects returns 83  
   effects sends 86  
   input channels 83  
   main stereo output meters 84  
   metering point 85  
   omni outs 84  
   option I/O 85  
   peak hold 84  
   stereo output 84  
 Metering point page 85  
 Mic inputs 20  
 MIDI  
   about 222  
   about the connectors  
     about 23  
   bulk dump 232  
   bulk page 232  
   bulk setup 226  
   control change page 229  
   control change setup 225  
   data format 280  
   definition 294  
   implementation chart 290  
   linking 01Vs 239  
   local control 234  
   local control page 234  
   MMC 236  
   parameter change setup 225  
   parameter control 229  
   ports 222  
   program change page 227  
   program change setup 225  
   receive channel 225  
   receive indicators 224  
   scene recall 227  
   setup 224  
   setup page 224  
   summary 7  
   system exclusive parameter  
     control 231  
   transmit channel 225

user define page 238  
 user defined controllers 238  
 using ports 223  
 MIDI data format 280  
 MIDI Device Number, definition 294  
 MIDI page 1 224  
 MIDI page 2 227  
 MIDI page 3 229  
 MIDI page 4 232  
 MIDI page 5 234  
 Mix parameter, input delay 45  
 Mix scenes  
   definition 294  
 Mix scenes. *See* Scene memories  
 Mixdown solo mode 80  
 MMC 236  
   definition 294  
 MMC control page 236  
 MOD.DELAY 140  
 MOD.FILTER 146  
 Modulation, definition 294  
 MONI TRIM 78  
 MONITOR OUT  
   about 22  
   using 77  
 MONITOR OUT LEVEL control  
   about 15  
   using 77  
 Monitor setup page 78  
 MONITOR-2TR IN switch  
   about 15  
   using 77  
 Monitoring  
   about 76  
   AFL/PFL 78  
   aux sends 94  
   block diagram 79  
   bus outs 108  
   D/A converters 77  
   effects returns 131  
   input channels 50  
   MONITOR OUT 22  
   MONITOR-2TR IN switch 77  
   mono/stereo 78  
   setup 78  
   specifications 266  
   stereo output 88  
   using 78  
 MONO DELAY 139  
 Motorized faders 5  
 MSB, definition 295  
 MULTI FILTER 156  
 Muting

aux sends 100  
 bus outs 109  
 effects returns 130  
 effects send masters 129  
 grouping channels 56  
 input channels 46  
   stereo output 90  
 MY4-AD 4 Analog Input 216  
 MY4-DA Analog Output 216  
 MY8-AD 8 Analog Input 216  
 MY8-AE AES/EBU 216  
 MY8-AT ADAT 216  
 MY8-TD Tascam 216  
  
**N**  
 Naming. *See* Titling  
 Noise gate, definition 295  
 Nominal fader indicator 30  
 Nominal Level, definition 295  
 Normal phase 42  
 Nyquist theorem, definition 295

**O**  
 Omni  
   definition 295  
 OMNI OUT 22  
 Omni out select page 116  
 Omni outs  
   about 116  
   assigning 116  
   aux sends 94  
   block diagram 118  
   bus outs 108  
   connectors 22  
   D/A converters 116  
   delay 117  
   input channels 50  
   meter page 84  
   metering 84  
   specifications 265  
   stereo output 88  
 ON buttons  
   about 18  
   aux sends 100  
   effects send masters 129  
   fader modes 34  
   input channels 46  
   master 90  
   reassigning 194  
 Operating level, definition 295  
 Option I/O

about the cards 216  
 assigning outputs 219  
 aux sends 94  
 block diagram 220  
 bus outs 108  
 card specs 217  
 control page 43, 63, 95, 97, 123, 126  
 input channels 50  
 input specifications 264  
 installing cards 218  
 metering 85  
 output specifications 266  
 select page 219  
 stereo output 88  
 summary 6  
 swapping inputs 51  
 OPTION I/O slot  
   about 23  
   available cards 216  
   installing cards 218  
 Option in meter page 85  
 Option out meter page 85  
 OPTION page 1 85  
 OPTION page 2 43, 47, 49, 58, 63, 95, 97, 123, 126  
 OPTION page 3 85  
 OPTION page 4 219  
 OPTION page 5 51  
 Oscillator 202  
 Oscillator page 202  
 Output delay page 91, 117  
 Oversampling, definition 295

**P**  
 PAD switch  
   about 15  
   using 41  
 Page area, display 29  
 Pages  
   aux pan 102  
   aux pre/post 95, 96, 97, 99, 100  
   bulk 232  
   bus master 109, 110  
   CH copy 59  
   CH13-14 flip 213  
   control change 229  
   control, option I/O 43, 47, 49, 58, 63, 95, 97, 123, 126  
   Delay 45  
   dither 212  
   dynamics edit 164, 165, 166

- dynamics library 174, 175, 176
  - effect pre/post 125
  - effects edit 123, 124, 136, 137, 157
  - effects library 132, 133, 134, 135
  - EQ 43, 63, 64, 65
  - EQ library 67, 68, 69, 70
  - fade time 191
  - group 55, 56
  - input meter 83
  - input swap 51
  - internal parameter 194
  - local control 234
  - memory 186, 187, 189, 190
  - memory sort 190
  - metering point 85
  - MIDI setup 224
  - MMC control 236
  - monitor setup 78
  - omni out meter 84
  - omni out select 116
  - option I/O out select 219
  - option in meter 85
  - option out meter 85
  - oscillator 202
  - output delay 91, 117
  - pair 52, 101, 111
  - panpot 47
  - phase 42
  - preferences 203
  - program change 227
  - recall safe 192
  - routing 49
  - RTN/output meter 83
  - solo setup 80
  - ST out meter 84
  - user define 238
  - view 57, 86, 89, 98, 127, 130
  - wordclock select 209
  - Pair page 52, 101, 111
  - Pairing
    - aux sends 101
    - aux sends block diagram 105
    - bus outs 111
    - input channels 52
    - input channels pair block diagram 54
  - PAM, definition 295
  - PAN/ROUT page 1 47
  - PAN/ROUT page 2 49
  - PAN/ROUT page 3 109, 110
  - PAN/ROUT page 4 116, 213
  - Panning
    - bus to stereo 110
  - channel aux sends 102
  - effects returns 47, 131
  - input channels 47
  - modes 48
  - PAN/ROUT page 47
  - PANPOT AUTO SCREEN, preference 203
  - Panpot page 47
  - Parameter boxes, display 30
  - Parameter change
    - echo 225
    - on/off 225
  - Parameter control
    - system exclusive 231
  - PARAMETER wheel 31
  - Parameters
    - Dynamics processors preset programs 177
    - effects preset programs 138
    - EQ preset programs 71
  - PCM, definition 295
  - Peak hold 84
  - Peaking
    - definition 295
    - EQ 62
  - PEQ, definition 295
  - PFL, definition 295
  - PFL/AFL. *See* AFL/PFL
  - PHANTOM +48V ON-OFF switches 22
  - Phantom powering 41
  - Phantom powering, definition 295
  - Phase 42
  - Phase page 42
  - PHASER 143
  - Phone inputs 20
  - PHONES jack
    - connector 21
    - using 77
  - PHONES LEVEL control
    - about 15
    - using 77
  - Pink noise
    - definition 295
  - pink noise 202
  - Ports
    - about 222
    - MIDI 23
    - selecting 224
    - TO HOST 23
    - using MIDI 223
    - using TO HOST 223
  - Post fader, definition 295
  - Power cord 11
  - POWER switch 23
  - Powering down the 01V 11
  - Powering up the 01V 11
  - Pre fader, definition 295
  - Pre/post
    - aux sends 97
    - effects sends 125
    - monitoring 78
    - solo 80
  - Preferences 203
  - Preferences pages 203
  - Preset programs
    - dynamics list 163
    - dynamics parameters 177
    - effects list 121
    - effects parameters 138
    - EQ list 67
    - EQ parameters 71
  - Pro Tools, system 250
  - Problem solving 253
  - Program change
    - definition 295
    - echo 225
    - MIDI bulk dump 232
    - omni 225
    - on/off 225
    - page 227
    - scene memory assignment table 273
    - scene memory assignments 227
    - scene recall 227
    - using 228
  - Programmable mixer 01 parameter
    - to control change assignment table 277
  - Programs
    - dynamics list 163
    - dynamics parameters 177
    - effects list 121
    - effects parameters 138
    - EQ list 67
    - EQ parameters 71
  - Protecting scene memories 189
- ## Q
- Q
    - adjusting 63
    - definition 296
  - Quantization, definition 296

**R**

Rack mounting 259  
 Rear panel 22  
 Reassigning faders & on buttons  
   194  
 RECALL CONFIRMATION,  
   preference 203  
 Recalling  
   dynamics programs 175  
   effects programs 134  
   EQ programs 69  
   scene memories 187  
   undoing mix scene recalls 189  
 Receive channel, MIDI 225  
 Recording solo mode 80  
 Releasing  
   aux send pairs 101  
   bus out pairs 111  
   input channel pairs 53  
 REMOTE page 1 194  
 REMOTE page 2 236  
 REMOTE page 3 238  
 Renumbering scene memories 190  
 Request  
   local control 234  
   MIDI bulk dump 232  
 Resetting the EQ 66  
 Return controls  
   about 19  
   fader modes 35  
 REV+CHORUS 148  
 REV+FLANGE 149  
 REV+SYMPHO 150  
 REV->CHORUS 149  
 REV->FLANGE 150  
 REV->PAN 151  
 REV->SYMPHO 151  
 REVERB HALL 138  
 REVERB PLATE 138  
 REVERB ROOM 138  
 REVERB STAGE 138  
 REVERSE GATE 139  
 Reverse phase 42  
 RING MOD 146  
 RK124, rack-mount kit 259  
 ROTARY 145  
 Rotary controls, display 30  
 Routing  
   bus to stereo 110  
   effects returns 49  
   input channels 49  
   page 49  
 RTN/output meter page 83

**S**

Safe channels, mix scenes 192  
 Sampling rate  
   definition 296  
   setting 209  
 Scene memories  
   about 184  
   definition 296  
   display area 185  
   edit buffer 185  
   edit indicator 185  
   fade time 191  
   fade time page 191  
   memory 00 185  
   memory page 186, 187, 189,  
     190  
   memory sort page 190  
   MIDI bulk dump 232  
   number of memories 266  
   program change assignment  
     table 273  
   protecting 189  
   recall safe page 192  
   recalling 187  
   recalling via MIDI 188  
   renumbering 190  
   safe channels 192  
   storing 186  
   summary 7  
   titling 190  
   undoing recalls 189  
   what's stored 184  
 Security cover 259  
 SEL buttons  
   about 18  
   fader modes 32  
 SELECT CH MESSAGE, preference  
   203  
 Selected channel area, display 29  
 Selected channel controls  
   about 16  
   EQ controls 63  
 SETUP page 1 209  
 SETUP page 2 78, 80  
 SETUP page 3 55, 56  
 SETUP page 4 52, 101, 111  
 SETUP page 5 212  
 Shelving  
   definition 296  
   EQ 62  
 Signal to noise ratio, definition 296  
 Sine wave, oscillator 202  
 Snapshot, definition 296

**Solo**

about 76  
 AFL/PFL 80  
 block diagram 82  
 modes 80  
 setup 80  
 stereo output 88  
 using 81  
 SOLO buttons  
   about 18  
   fader modes 33  
 Solo setup page 80  
 SOLO status indicator 19  
 SOLO TRIM 80  
 Sonic performance 5  
 Specifications 280  
   analog inputs 268  
   analog outputs 268  
   aux sends 265  
   bus outs 265  
   control I/O 270  
   digital inputs 269  
   digital outputs 269  
   digital stereo input 264  
   digital stereo output 266  
   effects returns 264  
   EQ 267  
   general 261  
   input channels 263  
   monitor out 266  
   omni outs 265  
   option I/O inputs 264  
   option I/O outputs 266  
   stereo output 265  
 ST out meter page 84  
 STEREO DELAY 140  
 Stereo meters  
   about 16  
   using 84  
 STEREO OUT 23  
 Stereo output  
   2TR OUT 88  
   about 88  
   balancing 90  
   block diagram 92  
   connectors 23  
   D/A converters 88  
   delay 91  
   digital stereo output 88  
   dynamics processors 165  
   EQ 65  
   fader 90  
   level setting 90  
   metering 84

- monitoring 88
- muting 90
- omni outs 88
- option I/O 88
- solo 88
- specifications 265
- viewing settings 89

STORE CONFIRMATION,  
    preference 203

Storing

- dynamics programs 174
- effects programs 133
- EQ programs 68
- MIDI bulk dump 232
- scene memories 186

SW, user define 238

Swapping channel settings 59

Swapping input channels 51

Switches, display 30

Switching off the 01V 11

Switching on the 01V 11

SYMPHONIC 143

System examples

- ADAT-interface recorder 242
- general 10
- Pro Tools 250
- Tascam-interface recorder 246
- Two ADAT-interface recorders  
    244
- Two Tascam-interface  
    recorders 248

System exclusive

- definition 296
- parameter control 231

## T

Tamper proof cover 259

Tempo, effects parameter 137

THD, definition 296

Title edit dialog box 37

Titling

- dialog box 37
- dynamics programs 176
- effects programs 135
- EQ programs 70
- scene memories 190

TO HOST

- about 222
- about the connector  
    about 23
- using 223

Top panel 14

Transmit

- local control 234
- MIDI bulk dump 232

Transmit channel, MIDI 225

Transport control, MMC 236

TREMOLO 144

Troubleshooting 253

Turning off the 01V 11

Turning on the 01V 11

## U

Undoing mix scene recalls 189

Unity gain, definition 296

Unlatch, user define 238

User define page 238

User defined MIDI controllers 238

UTILITY page 1 202

UTILITY page 2 203

## V

VIEW page 1 57, 86, 89, 98, 127,  
    130

VIEW page 2 57, 86, 89, 98, 127,  
    130

VIEW page 3 59

Viewing settings

- aux sends 98
- effects returns 130
- effects sends 127
- input channels 57
- stereo output 89

## W

Web site 291

Width, 01V dimensions 271

Wordclock

- about 206
- definition 296
- important information 11
- setting 209

Wordclock select page 209

Wordlength 212

## X

XLR inputs 20



YAMAHA CORPORATION  
Pro Audio & Digital Musical Instrument Division  
P.O. Box 3, Hamamatsu, 430-8651, Japan