



TCS SERIES

USER MANUAL

Turbosound Ltd.
Star Road, Partridge Green
West Sussex RH13 8RY UK
Tel: +44 (0)1403 711447 Fax: +44 (0)1403 710155
web: www.turbosound.com

Issue 1.3 October 2005
Copyright © 2005 Turbosound Ltd.

Contents

Thanks	5
Unpacking the TCS series loudspeaker.....	5
Introduction	6
Features	6
Product Range Summary	7
System Requirements	10
Amplifier considerations	10
System Configurations.....	11
LMS-D6 Loudspeaker Management System.....	13
Features	13
Loudspeaker Connections.....	14
Connecting Cables	15
Flying and lifting.....	15
Flying and lifting.....	16
General	16
Flying single enclosures.....	17
Installation of a single TCS series enclosure using eyebolts	20
Installation of a single TCS series enclosure using Turbosound or Omnimount hardware.....	20
Installation of a single TCS series enclosure using WB-10, WB-20, W-55, CB-10, CB-55 wall and ceiling brackets	21
Installation of a single TCS series enclosure using SB-30 and SB-40 swivel brackets.....	21
Rigging Instructions for a 2-wide TCS-56/59 array.....	23
Rigging Instructions for a 2-wide TCS-56/59 array.....	24
Rigging Instructions for a 3-wide TCS-56/59 array.....	25
Rigging the TCS-40 with 3-wide TCS-56/59 arrays.....	26
Appendix A	27
Technical Specifications.....	27
Appendix B: Warranty.....	29
Limited Warranty	29
Warranty Coverage.....	29
Shipping	29

user manual
TCS series

Incidental and consequential damages	30
Limitation of implied warranties	30
Appendix C	31
Use of thread locking compounds	31
Notes	32

THANKS

Thank you for choosing a TURBOSOUND TCS series loudspeaker product for your application. Please spare a little time to digest the contents of this manual, so that you obtain the best possible performance from this unit.

All TURBOSOUND products are carefully engineered for world class performance and reliability.

If you would like further information about this or any other TURBOSOUND product, please contact us. Detailed product information is available on our web site at www.turbosound.com

We look forward to helping you in the near future.

Unpacking the TCS series loudspeaker

After unpacking the unit please check carefully for damage. If damage is found, please notify the carrier concerned at once. You, the consignee, must instigate any claim. Please retain all packaging in case of future re-shipment.

Introduction

Congratulations, you have just purchased a professional loudspeaker product from the TCS Series sound contracting loudspeaker range, designed to give you the best in audio quality and many years of reliable, trouble free operation. It offers excellent pattern control, superior audio quality, integral rigging and flying hardware options, full technical documentation including EASE data, and a comprehensive warranty against manufacturing defects. Please read through this manual carefully before you attempt to operate the loudspeaker system. It contains valuable information enabling you to quickly and easily connect the loudspeakers to your amplifiers, important system and set-up checks together with positioning and mounting instructions.

Features

- ◆ TCS series cabinets are constructed from high quality birch plywood; rebated, glued and screwed together for maximum strength and rigidity.
- ◆ Internal rigging points enable a wide variety of installation methods: with standard eyebolts; OmniMount hardware; and optional Turbosound wall and ceiling brackets.
- ◆ High quality components are used throughout the TCS range. Cast frame low frequency drivers give the combined benefits of high strength and low weight, while high frequency drivers are all selected for consistent and reliable performance.
- ◆ TCS series enclosures are supplied with a durable black textured paint finish as standard. Optional finishes include TurboBlue™ and white textured paint, or raw birch plywood for painting or staining on site to match venue décor requirements.
- ◆ Speakon NL4MP connectors and 4-way terminal strips are provided on a recessed rear panel to allow for input and loop-through connections. Wedge monitors are supplied with two Speakon NL4MP connectors for mobile use.
- ◆ TCS series full-range enclosures are designed to give good pattern control down to crossover frequency, and are fully supported with EASE polar data (available to download from the Turbosound web site at www.turbosound.com). This enables accurate and predictable results when specifying sound systems in a given venue.

Product Range Summary

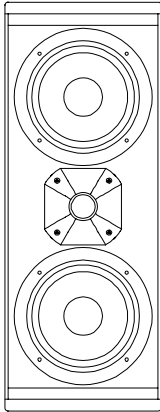

The **TCS-20** is a compact passive 2-way wide dispersion loudspeaker using two 5" LF drivers and a 1" neodymium soft dome HF tweeter for use in background and surround sound applications ranging from multimedia and audio visual to retail shopping malls. Its wide dispersion pattern of 120° by 120° makes it ideal for distributed and surround sound applications. The cabinet is fitted with M6 internal fixings for permanent installations using eyebolts, OmniMount™ series 50 hardware or optional Turbosound mounting brackets.

The **TCS-30** is a passive 2-way enclosure offering wide dispersion quality audio for theatre under-balcony and delay speaker applications. It uses two 5" LF drivers and a 100° x 60° HF horn. The cabinet is fitted with M6 internal fixings for permanent installations using standard eyebolts and optional Turbosound wall and ceiling brackets.

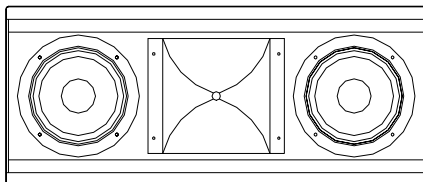

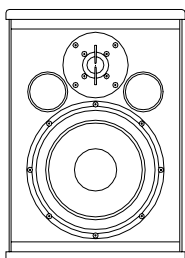

The **TCS-35** is a compact trapezoidal passive 2-way loudspeaker with a single 8" LF driver and a 1" titanium HF tweeter. It is designed for background sound applications in pubs, cafes, bars and restaurants. The cabinet is fitted with M6 internal fixings for permanent installations using optional OmniMount 75 series, Powerdrive 75 series and Turbosound wall and ceiling brackets.

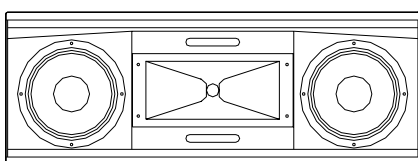

The **TCS-40** is a passive 2-way loudspeaker with 2 x 8" LF drivers and a 1" HF compression driver on a 90° x 40° horn. It can either be used as a downfill enclosure with TCS-56 or TCS-59 arrays, or in under-balcony or delay speaker applications. The cabinet is fitted with M10 internal steel rigging points for permanent installations using standard eyebolts or optional Turbosound wall and ceiling brackets.

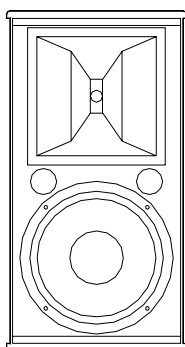

The **TCS-56** is a passive trapezoidal full range 2-way loudspeaker with a 12" LF driver and a 1" HF compression driver on a 60° x 40° constant directivity horn. Its controlled dispersion pattern makes it ideal for use in main sound reinforcement arrays for houses of worship and theatres. The HF horn can be rotated through 90° enabling horizontal cabinet orientation. The cabinet is fitted with M10 internal steel rigging points for permanent installations using standard eyebolts or optional Turbosound wall and ceiling brackets.

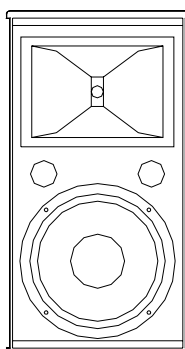

The **TCS-59** is a passive trapezoidal full range 2-way loudspeaker with a 12" LF driver and a 1" HF compression driver on a 90° x 60° constant directivity horn. The wide dispersion pattern is ideal for near field applications. The cabinet is fitted with M10 internal steel rigging points for permanent installations using standard eyebolts or optional Turbosound wall and ceiling brackets.

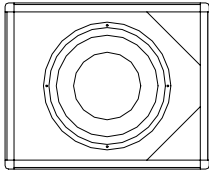

The **TCS-108** is a compact front loaded vented subwoofer with a high efficiency 8" low frequency driver. Its design allows multiple configurations adaptable to differing venue requirements by assembling units together with the supplied external brackets. The cabinet is fitted with M10 internal rigging points for permanent installations using standard eyebolts. The TCS-108 is also available with integral passive crossover network (TCS-108P), and as a self-powered product with an internal power amplifier module.

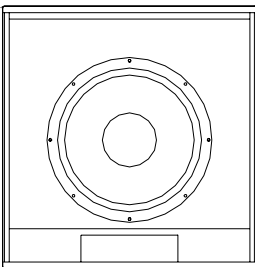

The **TCS-118** is a 1200 watt front loaded vented subwoofer using a high efficiency 4" voice coil 18" low frequency driver. Internal cabinet reflections are minimised by virtue of an angled speaker baffle. The cabinet is fitted with M10 internal steel rigging points for permanent installations using standard eyebolts.

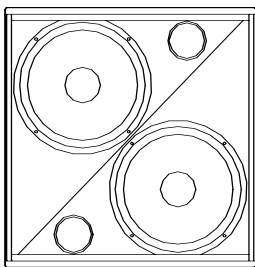

The **TCS-215** is a front loaded 1600 watt subwoofer using two high efficiency 3" voice coil 15" low frequency drivers fitted to individual off-set speaker baffles to minimise internal cabinet reflections. The cabinet is fitted with M10 internal steel rigging points for permanent installations using standard eyebolts.

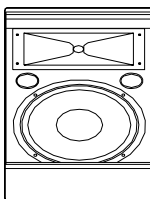

The **TCS-12M** is a front loaded 2-way passive wedge monitor for vocal and music monitoring. It comprises a 12" low frequency driver and a 1" high frequency compression driver on a 90° by 40° horn in an optimally ported 42° enclosure.

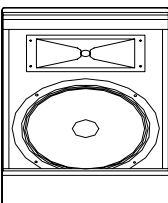

The **TCS-15M** is a front loaded 2-way passive wedge monitor for vocal and music monitoring. It comprises a 15" low frequency driver and a 1" high frequency compression driver on a 90° by 40° horn in a 42° enclosure.

System Requirements

TCS series 2-way enclosures are passive loudspeaker systems. This means that they require only one amplifier channel for correct operation, the frequency splitting between the low frequency driver and the high frequency driver being accomplished by the internal passive crossover network in each enclosure. If subwoofer enclosures are used in a bi-amplified system in conjunction with TCS series 2-way enclosures, additional amplifier channels and external electronic crossovers will be required. Turbosound LMS series digital management systems are recommended for this purpose.

Amplifier considerations

Turbosound loudspeaker enclosures should be driven by high quality power amplifiers designed for true professional use. Such amplifiers will have balanced inputs, DC and RF fault protection, and well designed cooling systems for reliability.

The program power listed in the loudspeaker's technical specification is the best guide to the size of amplifier required for general purpose applications. The amplifier should therefore be capable of delivering long term broadband power equal to the loudspeaker's program power rating at the loudspeaker's stated nominal impedance. This approach allows sufficient headroom to generate good dynamic range.

RECOMMENDED AMPLIFIER POWER RATINGS:

The amplifier's rated r.m.s. continuous power output (20Hz – 20kHz, per channel) should be equal to the program power handling of the loudspeaker at its nominal impedance.

In general, the more powerful the amplifier the better it will sound, provided that it is not driven into sustained clipping. It should be understood that overdriving an insufficiently powered amplifier is more likely to cause loudspeaker damage – the total energy in a heavily clipped signal is far higher than in an unclipped signal - than operating a more powerful amplifier within its ratings.

All the equipment in the system before the system controller should be set up for 0dBV (775mV) maximum output. One controller can be used to feed several amplifiers as long as all the amplifiers are the same (or have the same gain ratings). More than one controller may be required if the amplifiers are of different gain or type, please contact your dealer if you require help in this area.

System Configurations

Many different system configurations of TCS series loudspeaker enclosures are possible to suit various installation requirements, ranging from cafes, bars and restaurants to theme parks, theatres and houses of worship. Listed below are a few common examples.

- ◆ Full range system for small venues
 - 2 x TCS-59 wide dispersion enclosures
 - 1 x TMC-750 power amplifier

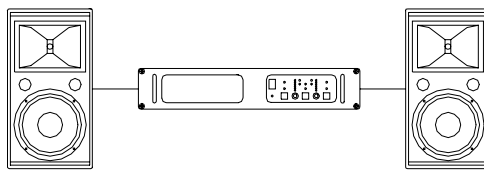

- ◆ Full range system with sub-bass for small venues
 - 6 x TCS-35 compact enclosures
 - 8 x TCS-108 compact sub-bass enclosures
 - 1 x LMS-D6 loudspeaker management system
 - 2 x TMC-750 power amplifiers

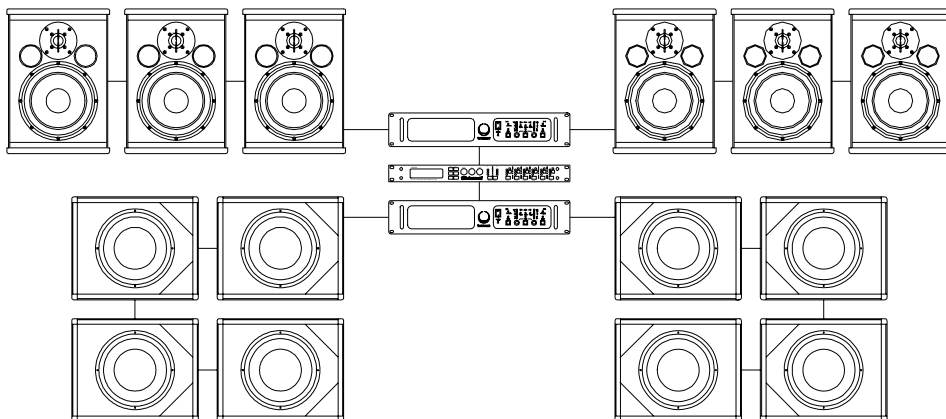

- ◆ Full range system for medium venues
 - 4 x TCS-56 medium dispersion enclosures
 - 4 x TCS-118 or TCS-215 sub-bass enclosures
 - 1 x LMS-D6 loudspeaker management system
 - 1 x TMC-750 power amplifier
 - 1 x TMC-1250 power amplifier

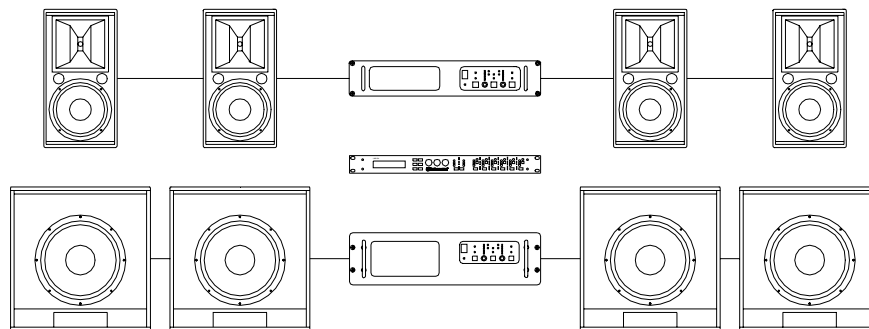

- ◆ Full range system with sub-bass for medium to large venues
 - 6 x TCS-56 medium dispersion enclosures
 - 2 x TCS-40 downfill enclosures
 - 4 x TCS-118 or TCS-215 sub-bass enclosures
 - 1 x TMC-750 power amplifier
 - 2 x TMC-1250 power amplifiers
 - 1 x LMS-D6 loudspeaker management system

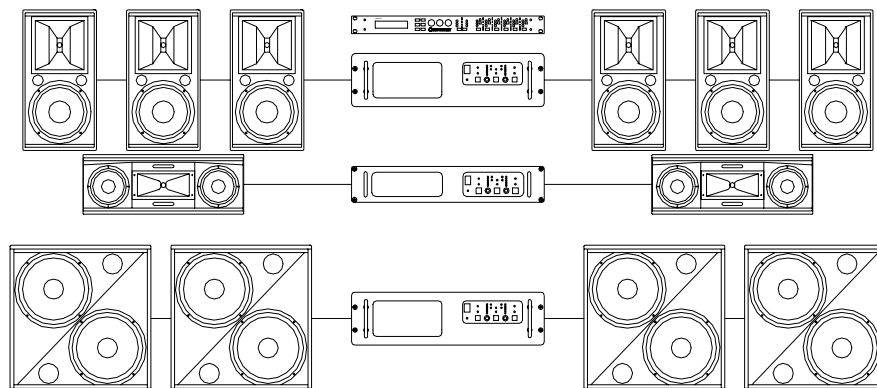

LMS-D6 LOUDSPEAKER MANAGEMENT SYSTEM

The LMS-D6 is a compact and powerful DSP based audio-processing unit, ideally suited for fixed installation applications, where it combines the functions of multiple conventional products in a compact 1U high unit. To achieve this the LMS-D6 has 2 inputs and 6 outputs, which can be configured in 5 basic modes: 3 x 2 way, 2 x 3 way, 4 way, 5 way and 6 way crossover. Each input has gain and delay. Each output consists of a high and lowpass filter, 5 bands of parametric equalisation, limiter, delay, gain and polarity controls. User memories are provided, and also a multi-level security 'lock-out' function for all controls. The LMS-D6 is also available with optional AES/EBU inputs and outputs. The LMS-D6 is designed for quick adjustment via easy-to-use front panel controls.

Features

- ◆ **Superb audio quality:** carefully optimised double precision processing plus 40 bit internal data path for exceptional dynamic range and sonic quality.
- ◆ **A flexible 2 input, 6 output** multi-mode format featuring a choice of 3 x 2 way, 2 x 3 way, 4 + 2 way, 5 + 1 way and 6 way crossover modes with limiters.
- ◆ **Each parametric section** provides +15dB to -30dB of gain at centre frequencies between 20Hz - 20kHz with a wide range of Qs from 0.4 to 128. All parameters feature fine resolution with 1/36th octave frequency steps, 0.1dB gain increments and 100 Q settings. Any parametric section can be set for LF & HF shelving response.
- ◆ **Six high performance limiters** are provided, featuring a wide range of control over Attack, Release and Threshold parameters. The output meters shows headroom to the limit threshold. The meter time constants track the limiter time constants to show precise power usage.
- ◆ **Variable high and low-pass filters** for each output can be set for 12, 18 and 24dB per octave slopes with a choice of Bessel, Butterworth or Linkwitz-Riley responses. Independent control over high & low-pass functions allows asymmetric crossover functions to be realised.
- ◆ **Three velocity-sensitive rotary encoders** provide a familiar and easy to use control format with all filter information displayed simultaneously on a backlit LCD display.
- ◆ **Delay of up to 650mS** can be independently set for each output with a minimum increment of 2.6µS.
- ◆ **Comprehensive standard specification** includes 20 user memories, and Turbosound's pre set memories.
- ◆ The LMS-D6 provides **exceptional audio quality** with a full >110dB dynamic range, high sampling rate and minimal filtering.

Loudspeaker Connections

TCS series enclosures are provided with a recessed connector panel housing a single Neutrik Speakon NL4MP connector wired in parallel with a 4-way terminal strip, or in the case of the TCS-12M and TCS-15M wedge monitors via two Neutrik Speakon NL4MP connectors wired in parallel. Either can be used for the input, the other being available as an output for looping to further TCS enclosures. Note that looping out to additional enclosures has the effect of reducing the total load impedance on the amplifier. For example, two 8 ohm cabinets in parallel give a combined total impedance of 4 ohms. Never connect loudspeakers to a power amplifier whose total combined impedance is lower than the amplifier's recommended minimum load impedance. Do not use the loop-out connection to connect any other type of loudspeaker as permanent damage may result!

The cable end Speakon connector should be wired as follows:

Positive output	Pin 1 +
Negative output	Pin 1 -

Please take care if XLR's, binding posts or other dual connector systems are used at the amplifier end of the loudspeaker cables (jack plugs/sockets should not be used) where there is a possibility of the cables being reversed. It is highly recommended that Neutrik Speakons or other heavy duty non-reversible connectors are used.

Connecting Cables

Heavy duty loudspeaker cable should always be used, with a minimum wire size of 12 gauge (1.5mm²), and preferably 10 gauge (2.5mm²) for longer runs, keeping the run as short as possible. This helps to avoid wasting amplifier power in the resistance of the cable. High cable resistance also lowers the *damping factor* of the amplifier that affects its ability to control loudspeaker cone movement. Losses due to undersized cable and long runs are clearly illustrated in the table below. Please use this table to determine the most suitable cable size and maximum run for your particular application.

Nominal Cable Area (mm ²)	Cable Length (m)	Cable Resistance (W)	Voltage Drop (%) 8 ohms		Sensitivity Loss (dB)	
			8W	4W	8W	4W
1.5	5	0.07	0.8	1.6	-0.1	-0.1
	10	0.13	1.6	3.2	-0.1	-0.3
	25	0.33	4.0	7.7	-0.4	-0.7
	50	0.67	7.7	14.3	-0.7	-1.3
	100	1.33	14.3	25.0	-1.3	-2.5
2.5	5	0.04	0.5	1.0	0.0	-0.1
	10	0.08	1.0	2.0	-0.1	-0.2
	25	0.20	2.4	4.8	-0.2	-0.4
	50	0.40	4.8	9.1	-0.4	-0.8
	100	0.80	9.1	16.6	-0.8	-1.6
4.0	5	0.02	0.3	0.6	0.0	-0.1
	10	0.05	0.6	1.2	-0.1	-0.1
	25	0.12	1.5	3.0	-0.1	-0.3
	50	0.25	3.0	5.8	-0.3	-0.5
	100	0.50	5.8	11.0	-0.5	-1.0

note : Figures based on specifications supplied by Van Damme Cables (VDC)

FLYING AND LIFTING

General

A versatile set of rigging parts has been designed for arrayable TCS series enclosures in order to give the installer a cost effective approach to flying and mounting, ranging from a single enclosure up to multi-box arrays and clusters.

All riggable products are fitted with metric internal fixings. It is expected that external parts such as eyenuts, flying bridles, scaffold clamps, safety chains etc. will be obtained locally from the usual suppliers and used with the parts available from Turbosound.

Any installation, whether temporary or permanent must be securely attached to the structure of the building using chain, steel wires or web straps which are certified and load rated for the purpose. The combined weight of the sound system, its cables and the rigging system must be safely carried by the points at which attachment is made to the building or structure. Great care must be taken in selecting the attachment points and methods, being absolutely sure of the load carrying capacity of points chosen.

IMPORTANT NOTE: The rigging of loudspeaker systems is an extremely serious matter with potentially lethal consequences should anything go wrong. It is of vital importance that you, or other people rigging the system, are suitably qualified to do so and have a full understanding of all the factors involved with safety as a number one priority. Turbosound accept no responsibility for any accident, damage or failure of any rigged system. This rigging information is specifically related to the requirements of the TCS series products only. For more detailed information on the whole topic of rigging various handbooks are available. If you are in any doubt contact your Turbosound dealer who will be able to refer you to an experienced rigging company.

All the sets and parts have been type tested and will be covered by "certificates of conformity" as to their ability to safely meet their design specification. These certificates are available on request.

Flying single enclosures

Single enclosures may be flown using a variety of different methods:

- ◆ Standard eyebolts (available from Turbosound or third party suppliers) attached to the rigging points provided on the top and back of the cabinet. The rigging point at the rear of the cabinet is used to alter the downward angle of the enclosure.

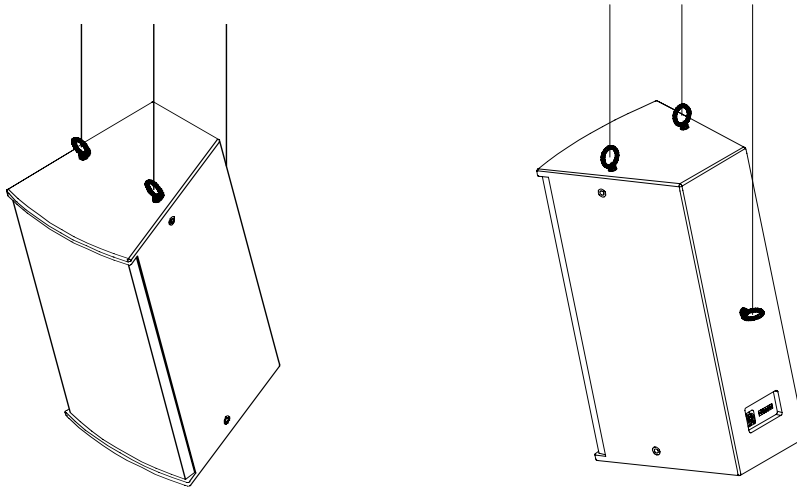

- ◆ OmniMount series 25, series 50, series 75 and Powerdrive series 75 wall and ceiling brackets (not supplied) for use with smaller TCS series enclosures such as the TCS-10, TCS-20, TCS-30 and TCS-35.

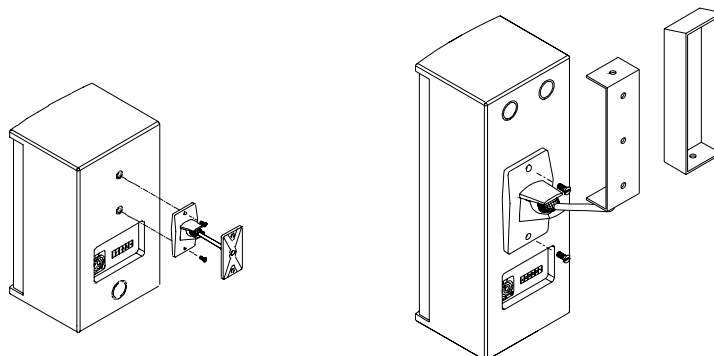

- ◆ Optional Turbosound WB-10 WB-60, WB-100 and CB-100 wall and ceiling brackets for use with many full range and mid-high cabinets including the TCS-10, TCS-20, TCS-30, TCS-35, TCS-40, TCS-56 and TCS-59.

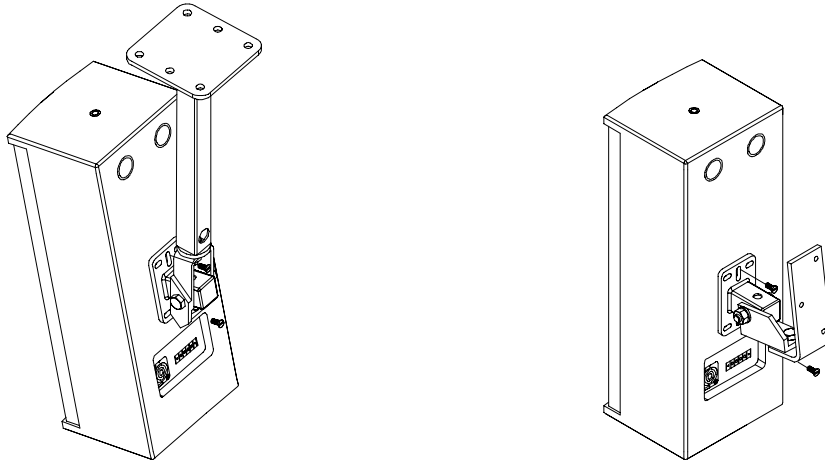

- ◆ Optional Turbosound swivel brackets, which can be used to mount TCS-20, TCS-30 and TCS-40 enclosures to walls or ceilings.

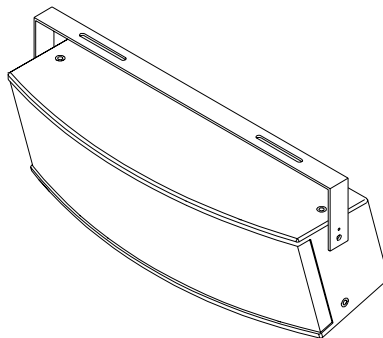

- ◆ Reconfigurable sub-bass cabinets: two units of TCS-108 subwoofers can be re-configured either as a horizontal or vertical block as shown below.

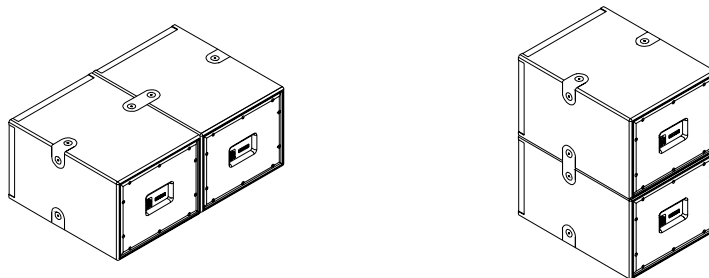

The table below indicates which type of installation hardware to use with which Turbosound TCS Series enclosure.

	Eyebolt	WB-10	WB-20	WB-55	CB-10	CB-55	SB-30	SB-40	OmniMount series 50	OmniMount series 75
TCS-20		◆			◆				◆	
TCS-30	◆	◆			◆		◆			
TCS-35	◆		◆			◆				◆
TCS-40	◆		◆			◆		◆		
TCS-56	◆			◆		◆				
TCS-59	◆			◆		◆				
TCS-108	◆									
TCS-118	◆									
TCS-215	◆									

Installation of a single TCS series enclosure using eyebolts

Parts required: 3 x M10 x 36mm shoulder eyebolts

3 x flat washers

3 x spring washers

1. Remove the captive countersunk bolts from the top and the rear of the cabinet using a flat blade screwdriver.
2. Insert the shoulder eyebolts, using a flat washer and spring washer as stand-offs. Apply a suitable thread locking compound such as Loctite 222 (see Appendix C), and tighten as necessary.
3. Angle the cabinet as necessary using the rigging point on the back.

Installation of a single TCS series enclosure using Turbosound or Omnimount hardware

Parts required: Turbosound or Omnimount wall or ceiling brackets as appropriate.

1. Ensure you have the correct bracket for the intended application and weight of the enclosure. Verify the weights of TCS series enclosures to be installed from the technical specifications section at the end of this manual.
2. Remove the captive countersunk bolts from the rear of the cabinet using a flat blade screwdriver.
3. Assemble the bracket to the enclosure using the bolts and hardware provided. Apply a suitable thread locking compound such as Loctite 222 (see Appendix C), and tighten as necessary.

Installation of a single TCS series enclosure using WB-10, WB-20, W-55, CB-10, CB-55 wall and ceiling brackets

Parts required: Turbosound wall or ceiling brackets as appropriate

4 x M10 x 36mm hex head bolts

4 x flat washers

4 x spring washers

1. Ensure you have the correct Turbosound bracket for the intended application and weight of the enclosure. Verify the net weight of TCS series enclosure to be installed from the technical specifications section at the end of this manual.
2. Remove the captive countersunk bolts from the rear of the cabinet using a flat blade screwdriver.
3. Attach the Turbosound bracket using the hardware provided. Apply a suitable thread locking compound such as Loctite 222 (see Appendix C), and tighten as necessary.

Installation of a single TCS series enclosure using SB-30 and SB-40 swivel brackets

Parts required: Turbosound swivel brackets as appropriate

2 x M10 x 36mm hex head bolts

2 x flat washers

2 x spring washers

2 x No.6 x 1" woodscrews

1. Remove the captive countersunk bolts from the top of the cabinet using a flat blade screwdriver.
2. Assemble the swivel bracket to the enclosure using the spring washers and flat washers as stand-offs. Apply a suitable thread locking compound such as Loctite 222 (see Appendix A), and tighten as necessary.
3. Adjust the cabinet angle as necessary and lock by inserting the No.6 woodscrews through the swivel bracket into the side of the cabinet.

Flying multiple TCS-56/59 enclosures

TCS-56 and TCS-59 cabinets are equipped with a total of nine internal rigging points on the top, bottom and sides. The threaded rigging points are comprised of steel angle brackets which also serve to tie the top panel of the cabinet to the sides, and the sides to the bottom panel of the cabinet. Therefore when flown the load is taken through the rigging points, and not through the joints between the cabinet panels, resulting in safe and efficient flying procedures.

The rigging points are utilised by removing the captive countersunk bolts from the cabinet fittings and replacing them with either standard shoulder eyebolts or regular hex-head bolts, which also serve to secure the cabinets to the fly bars. Setting the desired horizontal splay angles is achieved by the positioning of these bolts within the indented slots – marked in degrees – machined into the fly bars.

The TCS-40 downfill enclosure may be flown underneath a TCS-56/59 array by attaching a further steel yoke (SB-40) which permits variable downward inclination as well as serving to tie the TCS-56/59 cabinets together.

Four flying component assemblies enable the installer to assemble flown arrays with horizontal coverage angles from approximately 70° up to 180°, with or without downfill coverage. These are:

- **FB-550/2** (1 x TP-55/2 and 1 x BP-55/2) to fly a single row of 2 TCS-56/59 enclosures
- **FB-550/3** (1 x TP-55/3 and 1 x BP-55/3) to fly a single row of 3 TCS-56/59 enclosures
- **FB-554/2** (1 x TP-55/2 and 1 x SB-40) to fly a single row of 2 TCS-56/59 enclosures plus TCS-40 downfill
- **FB-554/3** (1 x TP-55/3 and 1 x SB-40) to fly a single row of 3 TCS-56/59 enclosures plus TCS-40 downfill

All the flying bar assemblies are designed to accommodate only one (horizontal) row of enclosures. They have not been designed to fly additional rows of TCS enclosures and should not be used for this purpose.

The key elements in flying arrays of TCS series enclosures are laser-cut steel fly bars manufactured by Turbosound which form the basis of simple, unobtrusive and versatile flying bar assemblies to enable the rigging of 2-wide and 3-wide TCS-56/59 clusters using the minimum of additional accessories and hardware. This allows the formation of arched arrays with adjustable angles up to a maximum of 180° horizontal coverage angle.

- **TP-55/2** 2-way flying assembly top plate and a **BP-55/2** 2-way flying assembly bottom plate. It is used to connect two TCS-56/59 enclosures together with a splay angle between cabinets of up to 30° in increments of 5°

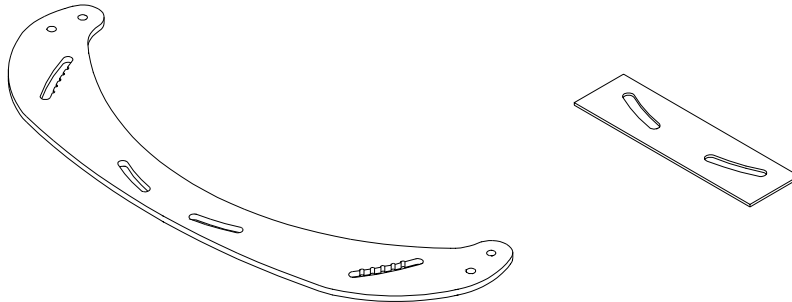

TP-55/2

BP-55/2

- **TP-55/3** 3-way flying assembly top plate and a **BP-55/3** 3-way flying assembly bottom plate. It is used to connect three TCS-56/59 enclosures together with a splay angle between cabinets of up to 30° in increments of 5°. The TP-55/3 top plate is supplied in two identical halves for handling convenience

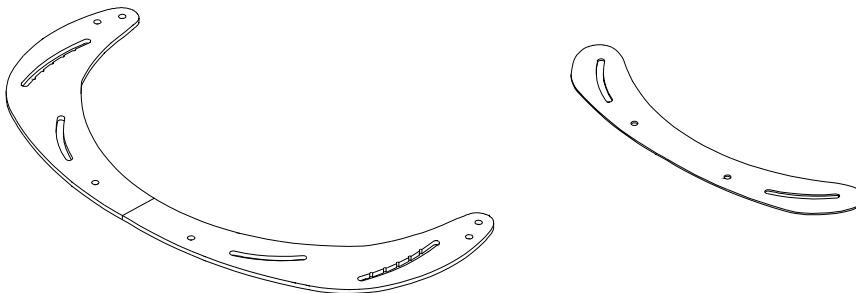

TP-55/3

BP-55/3

- **SB-40** swivel bracket used to suspend a TCS-40 downfill enclosure

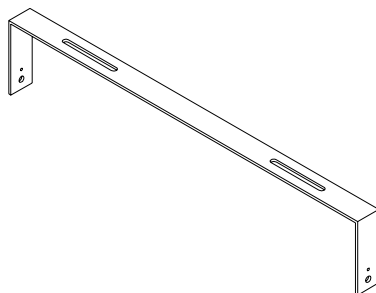

Rigging Instructions for a 2-wide TCS-56/59 array

Parts required: 2 x TCS-56 or TCS-59 enclosures
1 x TP-55/2 flying assembly top plate
1 x BP-55/2 flying assembly bottom plate
4 x M10 x 36mm shoulder eyebolts
4 x M10 x 36mm hex head bolts
8 x flat washers
8 x spring washers

1. Set the cabinets out on the floor with the approximate desired horizontal splay angle.
2. Remove the countersunk screws from the rigging points on the top of the cabinets.
3. Set the TP-55/2 flying assembly top plate on the cabinets, aligning the slots with the enclosure rigging points.
4. Assemble the top plate to the cabinets using M10 x 36mm eyebolts on the outer rigging point on each cabinet, and M10 x 36mm hex head bolts on the inner rigging point on each cabinet.
5. Set the cabinets to the desired horizontal angle using the indented positions on the top plate. As a starting point this will generally be 0° between cabinets (tight packed) in the case of the TCS-56, and 30° between cabinets in the case of the TCS-59.
6. Invert the array and attach the BP-55/2 bottom plate to the bottom of the cabinets by removing the countersunk screws and replacing them with M10 x 36mm hex head bolts.
7. Make final adjustments to the angle between cabinets in order to achieve the best coverage from the array. Tighten all hardware and prepare to lift the array into position.
8. Downward inclination of the completed array can be set using the eyebolts attached to the rear rigging points on the TCS-56/59 cabinets.
9. Attach safety chains to the holes at the rear of the flying assembly top plate.

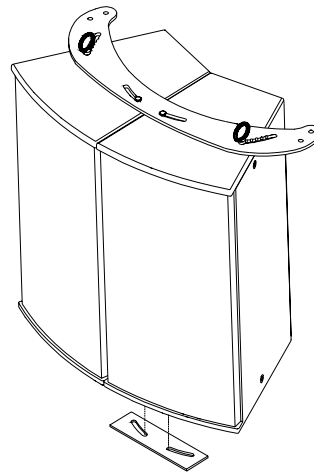

Rigging Instructions for a 3-wide TCS-56/59 array

Parts required: 3 x TCS-56 or TCS-59 enclosures
1 x TP-55/3 flying assembly top plate
1 x BP-55/3 flying assembly bottom plate
4 x M10 x 36mm shoulder eyebolts
8 x M10 x 36mm hex head bolts
12 x flat washers
12 x spring washers

1. Set the cabinets out on the floor with the approximate desired horizontal splay angle.
2. Remove the countersunk screws from the rigging points on the top of the cabinets.
3. Set the TP-55/3 flying assembly top plates (two are required per array) on the cabinets, aligning the slots with the enclosure rigging points.
4. Assemble the top plates to the cabinets using M10 x 36mm eyebolts and M10 x 36mm hex head bolts as shown.
5. Set the cabinets to the desired horizontal angle using the marked positions on the top plate. As a starting point this will generally be 0° between cabinets (tight packed) in the case of the TCS-56, and 30° in the case of the TCS-59.
6. Invert the array and attach the BP-55/3 bottom plate to the bottom of the cabinets by removing the countersunk screws and replacing them with M10 x 36mm hex head bolts.
7. Make final adjustments to the angle between cabinets in order to achieve the best coverage from the array. Tighten all hardware and prepare to lift the array into position.
8. Downward inclination of the completed array can be set using the eyebolts attached to the rear rigging points on the two outside TCS-56/59 cabinets.
9. Attach safety chains to the holes provided at the rear of the flying assembly top plates.

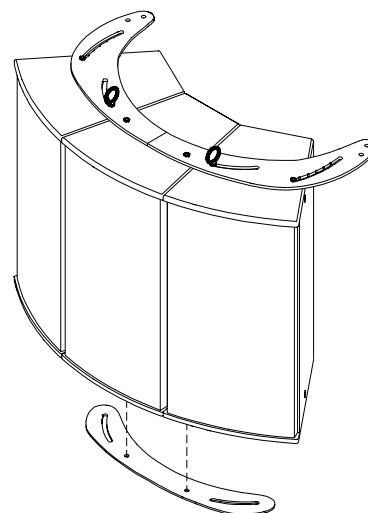

Rigging the TCS-40 with 3-wide TCS-56/59 arrays

Parts required: 3 x TCS-56 or TCS-59 enclosures
1 x TCS-40 enclosure
1 x TP-55/3 flying assembly top plate
1 x SB-40 swivel bracket
4 x M10 x 36mm shoulder eyebolts
6 x M10 x 36mm hex head bolts
8 x flat washers
8 x spring washers
2 x No.6 x 1" woodscrews

1. Assemble the array as described in steps 1 to 5 on the previous page.
2. Invert the array and attach the SB-40 bracket to the bottom of the cabinets by removing the countersink screws and replacing them with M10 x 36mm hex head bolts.
3. Attach the TCS-40 enclosure using M10 x 36mm hex head bolts. The enclosure is designed with a 15° top panel angle to allow it to be positioned close to the TCS-56/59 enclosures and angled downwards. Further adjustment to the desired downward angle can then be made. Use the small holes in the ends of the SB-40 swivel bracket to lock the cabinet at the required angle using the No.6 woodscrews.
4. Tighten all hardware and prepare to lift the array into position.

Attach safety chains to the holes provided at the rear of the flying assembly top plates.

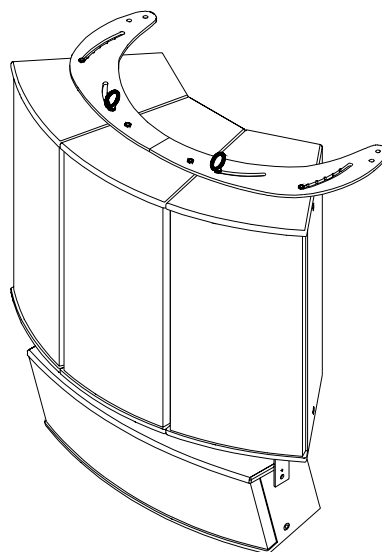

APPENDIX A

Technical Specifications

	TCS-20	TCS-30	TCS-35	TCS-40	TCS-56	TCS-59
Dimensions	426mm x 162mm x 140mm (16.8" x 6.4" x 5.5")	210mm x 494mm x 190mm (8.3" x 19.5" x 7.5")	385mm x 274mm x 286mm (15.2" x 10.8" x 11.3")	296mm x 806mm x 260mm (11.6" x 31.8" x 10.2")	700mm x 370mm x 389mm (27.6" x 14.6" x 15.3")	700mm x 370mm x 389mm (27.6" x 14.6" x 15.3")
Net weight	4.5kg (9.9lbs)	8.5kg (18.7lbs)	9.7kg (21.3lbs)	19kg (41.8lbs)	22kg (48.4lbs)	22kg (48.4lbs)
Components	2 x 5" LF, 0.5" HF	2 x 5" LF, 1" HF	1 x 8" LF, 1" HF	2 x 8" LF, 1" HF	12" LF, 1" HF	12" LF, 1" HF
Frequency response	70Hz – 20kHz ± 4dB	70Hz – 20kHz ± 4dB	55Hz – 20kHz ± 4dB	75Hz – 20kHz ± 4dB	60Hz – 20kHz ± 4dB	60Hz – 20kHz ± 4dB
Dispersion	120° H x 120° V	100° H x 60° V	120° H x 120° V	100° H x 40° V	60° H x 40° V	90° H x 60° V
Power handling	120 watts rms 240 watts program 300 watts peak	125 watts rms 250 watts program 315 watts peak	200 watts rms 400 watts program 500 watts peak	240 watts rms 480 watts program 600 watts peak	290 watts rms 580 watts program 725 watts peak	290 watts rms 580 watts program 725 watts peak
Sensitivity	90dB, 1W @ 1m	90dB, 1W @ 1m	89dB, 1W @ 1m	96dB, 1W @ 1m	97dB, 1W @ 1m	97dB, 1W @ 1m
Max SPL	120dB peak	120dB peak	121dB peak	128dB peak	131dB peak	131dB peak
Impedance	8 ohms	8 ohms	8 ohms	8 ohms	8 ohms	8 ohms

APPENDIX A

Technical Specifications (continued)

	TCS-108	TCS-108SP	TCS-118	TCS-215	TCS-12M	TCS-15M
Dimensions	274mm x 337mm x 440mm (10.8" x 13.3" x 17.4")	274mm x 337mm x 520mm (10.8" x 13.3" x 20.5")	730mm x 705mm x 482mm (28.7" x 27.7" x 19.0")	730mm x 705mm x 482mm (28.7" x 27.7" x 19.0")	558mm x 350mm x 361mm (22" x 13.8" x 14.2")	653mm x 442mm x 422mm (25.7" x 17.4" x 16.6")
Net weight	11.5kg (25.3lbs)	18.3kg (40.2lbs)	45kg (99lbs)	48kg (105.6lbs)	17kg (37.4lbs)	27kg (59.4lbs)
Components	1 x 8" LF	1 x 8" LF	1 x 18" LF	2 x 15" LF	12" LF, 1" HF	15" LF, 1" HF
Frequency response	43Hz – 140Hz ± 4dB	43Hz – 140Hz ± 4dB	34Hz – 150Hz ± 4dB	41Hz – 200Hz ± 4dB	60Hz – 20kHz ± 4dB	60Hz – 20kHz ± 4dB
Dispersion	N/A	N/A	N/A	N/A	90° H x 40° V	90° H x 40° V
Power handling	175 watts rms 350 watts program	N/A	600 watts rms 1200 watts program	800 watts rms 1600 watts program	290 watts rms 580 watts program	340 watts rms 680 watts program
Sensitivity	91dB, 1W @ 1m	N/A	96dB, 1W @ 1m	99dB, 1W @ 1m	98dB, 1W @ 1m	96dB, 1W @ 1m
Max SPL	120dB peak	122dB peak	133dB peak	136dB peak	131dB peak	130dB peak
Impedance	8 ohms	N/A	8 ohms	4 ohms	8 ohms	8 ohms

Due to continuing product improvement the above specifications are subject to change.

APPENDIX B: WARRANTY

Limited Warranty

This Turbosound loudspeaker product is warranted to the original end-user purchaser and all subsequent owners for a period of two (2) years from the original date of purchase.

Warranty Coverage

Warranty coverage includes defects in materials and workmanship. It does not include:

- ◆ damage caused by accident, misuse, abuse, neglect or modification by any other person other than an authorised Turbosound representative,
- ◆ damage caused by overdriving, use with unsuitable amplifiers or amplifier failure,
- ◆ damage caused by failure to operate the product in accordance with the instructions contained in the user's manual,
- ◆ damage occurring during shipment in transit,
- ◆ claims based upon any misrepresentations by the seller,
- ◆ products which do not have the original components as specified in the product engineering information,
- ◆ products on which the serial number has been removed or defaced.

Shipping

Should any fault develop with a component of your Turbosound system, please return the product, freight pre-paid, in its original packing carton, along with proof of purchase such as the original bill of sale or receipted invoice, and a description of the suspected fault to Turbosound Ltd. (Att: Customer Service), Star Road, Partridge Green, West Sussex RH13 8RY, England, or your local authorised Turbosound representative. The product serial number must be quoted in all correspondence relating to the claim. Insurance is recommended, as Turbosound or its representatives are not liable for loss or damage in transit. Turbosound will pay for return freight costs should repairs be covered under warranty.

Incidental and consequential damages

Turbosound's liability is limited to the repair or replacement, at our option, of any defective product, and shall not be liable for any incidental and consequential damages including, without limitation, injury to persons or property or loss of use.

Limitation of implied warranties

All implied warranties, including warranties of merchantability and fitness for a particular purpose, are limited in duration to the length of this warranty.

This warranty is in addition to, and in no way detracts from, your statutory rights as a consumer. No other warranty is expressed or implied.

Please record your purchase information below for future reference:

Dealer Name

Dealer Address

.....

.....

Post / Zip Code

Dealer telephone / fax

Invoice number

Date of purchase

Unit serial number

APPENDIX C

Use of thread locking compounds

When assembling flying hardware to TCS series loudspeaker enclosures it is advisable to use thread-locking compounds to eyebolts and other bolts in order to avoid any possibility of loosening.

The recommended thread-locking compound is Loctite 222.

The threaded rigging points used in TCS series enclosures are manufactured from zinc-plated mild steel. Therefore, and additionally if the external bolts used are zinc-plated, zinc-passivated, stainless steel or anodised (as the majority are), then the corresponding activator, Loctite 7471, should be used to achieve 100% performance.

Application: Spray Loctite 7471 into the thread holes and allow to evaporate. Apply Loctite 222 thread locking compound to the bolts prior to fitting, allowing sufficient to fill all the engaged threads. Assemble components and tighten as necessary.

The parts may be disassembled by hand if required.

Notes

Turbosound Ltd.
Star Road, Partridge Green
West Sussex RH13 8RY England
Tel: +44 (0)1403 711447 Fax: +44 (0)1403 710155
web: www.turbosound.com