

ELECTRONIC LOUDSPEAKER SYSTEM CONTROLLER

**TX3**  
**USER MANUAL**

# Contents

<b>INTRODUCTION</b>	2
<b>OPERATING INSTRUCTIONS</b>	2
Preliminary advice and information	2
Input connections	3
Output connections	3
Operation	4
<b>TECHNICAL SPECIFICATIONS</b>	6
<b>SERVICING</b>	7
Fuse replacement	7
List of spare parts	7
Warranty	7
<b>Declaration of Conformity</b>	8

## INTRODUCTION

Thank you for purchasing the Tannoy **TX3** loudspeaker system controller.

The **TX3** is an advanced electronic controller intended to optimise the performance of the Tannoy **T300** Superdual loudspeaker system. It can be used in full range mode where it performs specific equalisation functions, extending the low frequency response of the **T300** significantly. It can also be switched to 2-way active mode for applications requiring greater capability at very low frequencies, where it provides a mono sub channel output with optimised high and low pass internal crossovers.

The **TX3** also features:

- Stereo operation.
- Balanced inputs and outputs.
- Individual sub level control.
- Low frequency EQ mode switch intended to tailor low frequency for floorstanding/monitor applications.
- Low frequency phase invert switch.
- High pass filters to protect against hazardous ultra low frequencies.
- Industry standard 19" rack-mounting.

As well as technical specifications, this manual contains some helpful advice on how to use the controller. Please take a few minutes to read it prior to installation.

## OPERATING INSTRUCTIONS

### Preliminary advice and information.

The information contained in this manual is relevant for the **TX3** controller only. The **TX3** is dedicated for use with the Tannoy **T300** loudspeaker system only. Degradation of the sound quality and unreliable operation will result if using an improper controller.

The Tannoy **TDX1** digital loudspeaker management system should be used for fully active operation. If you intend to use an OEM crossover/controller (i.e. Omnidrive™, XTA™) then contact Tannoy or your distributor for the correct operational parameters.

Please inspect the unit immediately after unpacking for signs of transit damage. In the unlikely event that this has occurred please inform the carrier and the supplier. It is always a good idea to keep the carton for possible future transportation.

**Before the TX3 is connected to the mains supply, make sure that the unit is selected for operation with the correct mains voltage.** This can easily be checked by looking at the rear panel, where the selected input voltage appears on the voltage selector itself, located near the mains socket. Where necessary, change the selection by sliding the switch to the correct position. The position marked 115V is suitable for any mains voltage from 100V to 120V, whereas the position marked 230V will suit any voltage between 220V and 240V.

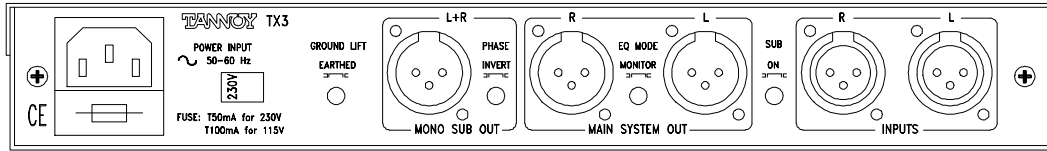

**Figure 1. TX3 rear panel**

**Input connections.**

As with other devices of its type, the **TX3** controller is inserted in the audio chain between the last link of audio source (mixing console, preamp, CD player, etc.) and the power amplifiers.

The two audio inputs are the female 3 pin XLR connectors on the rear panel, marked **L** for left and **R** for right. On each connector the signal is received between pins 2 and 3 and pin 1 is grounded.

Where the device connected at the input (i.e. console) and at the output (i.e. amplifier) is balanced, there is no hot and cold pin to worry about : the **TX3** is neutral polarity with pin to pin connections (pin 1 to pin 1, pin 2 to pin 2, pin 3 to pin 3). Note that the connection to pin 1 should be made using the cable shield.

Where a device with an unbalanced output (e.g. hi-fi, CD player or preamplifier) is connected to the input of the **TX3**, the signal should be applied to either pin 2 or pin 3 of the input XLR, according to which pin is 'hot' or +ve on the amplifier connected at the output. The unused signal pin (3 or 2 respectively) should then be linked to pin 1 for grounding (see Fig. 2).

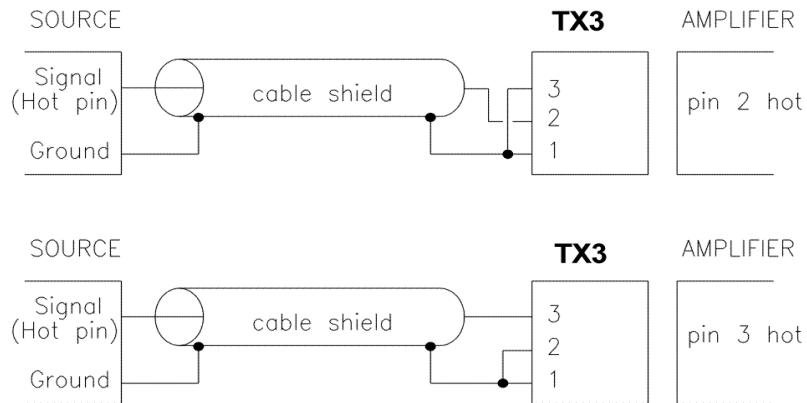

**Figure 2. Input connections from an unbalanced source**

**Output connections.**

The audio outputs are the three 3 pin male XLR connectors on the rear panel. The two (marked **L** for left and **R** for right) are the output channels for the main system, while the third one (marked **MONO SUB OUT**) is for the optional sub-bass system. On each of these connectors the signal is applied between pins 2 and 3 and pin 1 is grounded.

Where amplifiers with unbalanced inputs are used, the 'hot' or +ve pin of the amplifier input should be connected to either pin 2 or pin 3 of the **TX3** output XLR, according to which pin is the 'hot' pin on the device connected at the input. The unused signal pin (3 or 2 respectively) should then be linked to pin 1 for grounding. The use of amplifiers with unbalanced inputs - rather unusual for professional products - is not recommended, among other drawbacks it will cause the level to drop by 6dB on the outputs of the controller.

## Operation

The unit should be powered on (green LED illuminated on the front panel) before the amplifiers are switched on, this will avoid any switch noise or power surges which could damage the loudspeakers. Similar precautions should be taken when power is switched off (i.e. in reverse order).

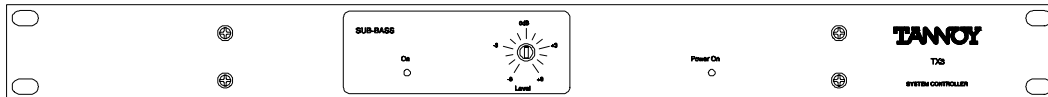

**Figure 3. TX3 front panel**

The simplified block diagram (Fig. 4.) shows TX3 operation with and without the sub-bass system.

When the rear panel 'SUB ON' push-button is in the 'out' position, the main - left and right - channels operate full range with the signal passing through the LF EQ section, resulting in an extension of the bottom end response of the system. This section consists of a 'High Q' 2nd order high pass filter which provides electronic boost where required and also cuts very low frequencies.

When the button is pushed in, with the red SUB-BASS LED on the front panel illuminated, the LF EQ section is bypassed and the signal on each main channel is re-routed via a high-pass filter at 100Hz designed to provide an optimised acoustic summation for the sub-bass system.

On the sub-bass channel, signals from both left and right inputs are summed together, and the resulting mono signal is low-pass filtered before being sent through the level control section.

To sum up: the push-button should be 'in' when a sub-bass system is used, 'out' when not (T300 running full range without additional sub-bass).

However it should be noted that the sub-bass channel itself is not affected by the position of the switch, which means that it is possible to have the main system operating full range while the sub-bass is also in operation. In that configuration both systems would overlap over a wide bandwidth, with a risk of phase cancellation occurring.

The **SUB-BASS** level control on the front panel can attenuate the sub-bass level by 12dB (-6 to +6). The potentiometer on the front panel is flush mounted in order to discourage any unauthorised adjustment. A small, flat blade screwdriver is required to adjust the Sub level.

The **EQ MODE MONITOR** push button is intended to tailor the bottom end for floor standing/monitor applications. When the **EQ MODE MONITOR** button is pressed 'in', the excess bottom end generated due to the close proximity of the floor (when used

as a 'wedge' monitor) is reduced by using a shelving filter. In some situations the T300 will be used close to a wall (half space loading), or in a corner (quarter space loading). It may be beneficial to use the **EQ MODE MONITOR** button in these instances if the bass frequencies sound 'overblown'.

The **PHASE INVERT** push button on the sub channel inverts the polarity of the sub bass signal. This is mainly implemented to operate the system in conjunction with Tannoy B400 sub-bass loudspeakers (see B400 user manual).

The **GROUND LIFT** push button connects/disconnects between the signal ground and the mains earth, which is linked to the chassis. Using this button may help eliminate hum caused by ground loops created in the system.

Situated inside the **TX3** on the main PCB next to the power supply is a jumper switch **JP1** which allows optimum configuration of the low frequency Hi-Pass filtering applied to the Sub channel. The '45' Hz position is intended for use with the B400, while the '30 Hz' position is intended for B950 and B475.

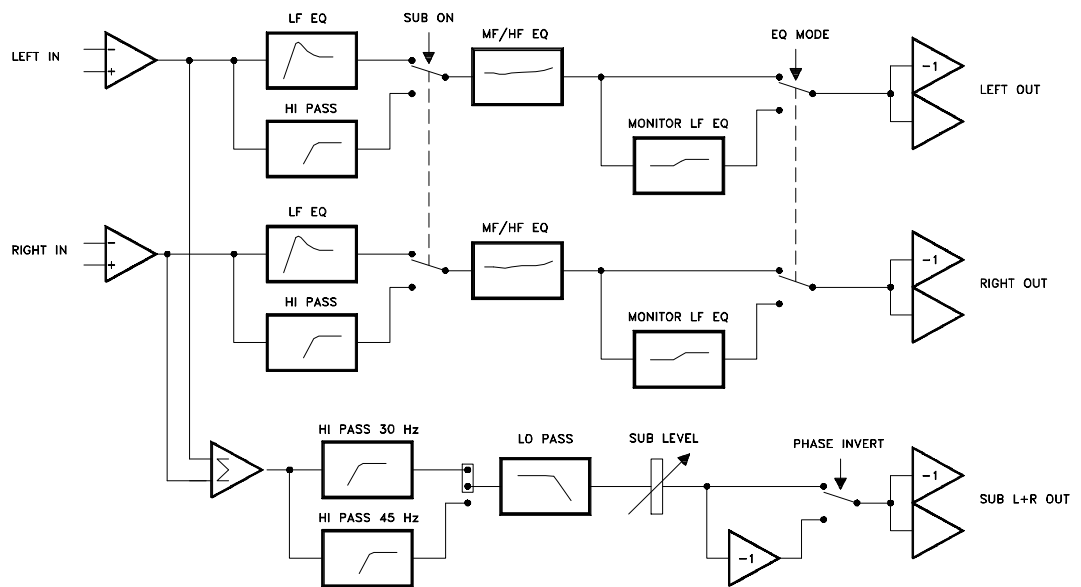

**Figure 4. TX3 simplified block diagram.**

## TECHNICAL SPECIFICATIONS

<b>Inputs</b>		Two electronically balanced inputs on 3 pin XLR connectors. Input impedance 10 k $\Omega$ .
<b>Outputs</b>		Three electronically balanced outputs on 3 pin XLR connectors. (Left, Right and Mono Sub) Output impedance 50 $\Omega$ . Max. level +20 dBV.
<b>Hum and Noise</b>		-90 dBV, 20 Hz - 20 kHz unweighted
<b>Controls and Indicators</b>	Front	Power on LED. Sub channel operation LED. Sub level control potentiometer, -6dB to +6dB.
	Rear	Sub channel operation switch EQ mode switch (main channels) Phase inversion switch (sub channel) Earth lift switch
<b>Mains supply</b>		IEC mains connector with integral fuse holder. Voltage selector for 115V or 230V operation (50/60Hz). Fuse type 5 x 20mm, rating T50mA - 250V for 230V operation, T100mA - 250V for 115V operation.
<b>Dimensions</b>		1U high, 19" rack mount width 44.5 mm H x 482 mm W x 150 mm D
<b>Weight</b>		1.7 kg

## SERVICING

If any servicing is required, it must only be carried out by qualified personnel. Do not remove the top cover, as there may be a risk of electric shock.

### Fuse replacement.

Disconnect the **TX3** from the mains power supply, and pull back the fuse drawer located at the bottom of the mains input. (A small screwdriver may be helpful.) The fuse drawer has two compartments, one containing the fuse under operation and the other a spare. Replacement fuses must be of the 5 x 20-mm type, and of the correct rating (indicated on the back of the unit).

Having replaced the fuse push the drawer in fully, until it is secured in its original position.

### List of spare parts.

This list does not include any individual electronic parts contained in the unit. For more detailed information please refer to the Service Manual or consult your local dealer or distributor.

PART NUMBER	DESCRIPTION
6481 0291	<b>TX3</b> User Manual
6883 0114	<b>TX3</b> Front Panel
6883 0103	<b>TX3</b> case. Chassis
6883 0095	<b>TX3</b> case. Top cover

## Warranty

No maintenance of the **TX3** controller is necessary.

All Tannoy electronic components are guaranteed for a period of one year from the date of manufacture, subject to the absence of, or evidence of, misuse, overload or accidental damage.

For further information please contact your dealer or the distributor in your country. If you cannot locate your distributor please contact:

Customer Services  
Tannoy Limited  
Professional Division  
Rosehall Industrial Estate  
Coatbridge  
Strathclyde ML5 4TF  
Scotland  
e-mail            service@tannoy.com

Telephone      01236 420199 (UK)      +44 1236 420199 (International)  
Fax              01236 428230 (UK)      +44 1236 428230 (International)  
e-mail            prosales@tannoy.com

DO NOT SHIP ANY PRODUCT TO TANNOY WITHOUT PREVIOUS AUTHORISATION.

This warranty in no way affects your statutory rights.



## Declaration of Conformity

The following apparatus is/are manufactured in the United Kingdom by Tannoy Ltd of Rosehall Industrial estate, Coatbridge, Scotland, ML5 4TF and conform(s) to the protection requirements of the European Electromagnetic Compatibility Standards and Directives relevant to Domestic Electrical Equipment. The apparatus is designed and constructed such that electromagnetic disturbances generated do not exceed levels allowing radio and telecommunications equipment and other apparatus to operate as intended, and, the apparatus has an adequate level of intrinsic immunity to electromagnetic disturbance to enable operation as specified and intended.

The apparatus complies with the Principal Elements of the Safety Objectives of the Low Voltage Directive 73/23/EEC.

Details of the Apparatus:

Tannoy Active Crossover/Equaliser  
Model Number: TX3

Associated Technical File:

EMCTX3

Applicable Standards:

EN 50081-1 Emission  
EN 50082-1 Immunity  
EN 60065:1994

Signed:



Position:

Technical Manager  
Tannoy Professional

Date:

16<sup>th</sup> July 1998

For Tannoy Ltd

---

**Tannoy Loudspeakers are manufactured  
in Great Britain by :**

**Tannoy Limited, Coatbridge, ML5 4TF. SCOTLAND**  
**Telephone: +44 (0)1236 420199 Fax: +44 (0)1236 428230**  
**Internet: <http://www.tannoy.com>**

TGI/Tannoy, 300 Gage Avenue, Kitchener, Ontario, CANADA, N2M 2C8  
Telephone: (519) 745 1158 Fax: (519) 745 2364

Tannoy Nederland BV, Anthonetta Kuijlstraat 19, 3066 GS, Rotterdam THE NETHERLANDS  
Telephone: (010) 2860554 Fax: (010) 2860431

Tannoy is a member of the  Group of Companies Issue 1 Part No. 6481 0291