

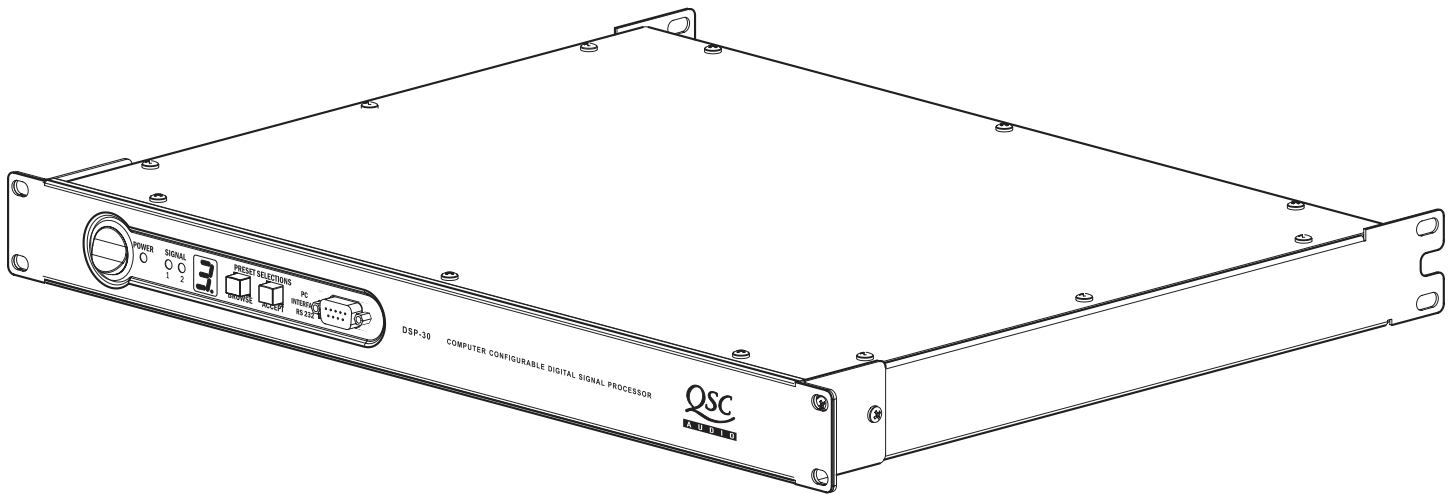

# DSP-30

## Computer Configurable Digital Signal Processor



TD-000097-00  
Rev.C

## WARNING!

WHILE QSC HAS ENDEAVORED TO DEVELOP AND PRODUCE THE MOST DEPENDABLE AND ROBUST DIGITAL SIGNAL PROCESSOR (DSP) AUDIO PRODUCT FOR YOUR USE, DUE TO THE UNLIMITED AND POTENTIALLY DESTRUCTIVE (TO THE SOUND SYSTEM) CONFIGURATIONS THAT MAY BE APPLIED TO THE DSP BY THE USER, QSC CANNOT BE HELD RESPONSIBLE FOR DAMAGES RESULTING FROM ANY DEVIATION OR FAILURE BY THE USER TO STRICTLY FOLLOW THE RECOMMENDATIONS SET FORTH IN THE OWNER'S MANUAL FOR THE INTEGRATION OF THE DSP AND SIGNAL MANAGER SOFTWARE WITH YOUR SOUND SYSTEM.

ALL RISKS ATTENDANT TO INTEGRATION OF USER-CONFIGURABLE DSP PRODUCTS WITH YOUR SOUND SYSTEM ARE ASSUMED BY YOU. WHILE QSC STRIVES TO SUPPLY THE HIGHEST QUALITY TECHNICAL SOLUTIONS FOR DIGITAL SIGNAL PROCESSING, IN NO EVENT WILL QSC OR ITS SUPPLIERS BE HELD LIABLE FOR ANY DAMAGES, CONSEQUENTIAL, INCIDENTAL, OR OTHERWISE, INCLUDING ANY CLAIMS FOR LOST PROFITS AND/OR SAVINGS RESULTING FROM ANY ATTEMPTED INTEGRATION OF THE DSP AND SIGNAL MANAGER SOFTWARE WHICH DOES NOT STRICTLY ADHERE TO THE MANUAL'S RECOMMENDATIONS.

### Federal Communications Commission (FCC) Information

NOTE: This equipment has been tested and found to comply with the limits for a Class B digital device, pursuant to Part 15 of the FCC Rules. These limits are designed to provide reasonable protection against harmful interference in a commercial installation. This equipment generates, uses, and can radiate radio frequency energy and, if not installed and used in accordance with the instructions, may cause harmful interference to radio communications. Operation of this equipment in a residential area is likely to cause harmful interference, in which case the user will be required to correct the interference at his or her own expense.

### IMPORTANT SAFETY INFORMATION: PLEASE REVIEW!

#### EXPLANATION OF GRAPHICAL SYMBOLS



The lightning flash with arrowhead symbol, within an equilateral triangle, is intended to alert the user to the presence of uninsulated "dangerous voltage" within the product's enclosure that may be of sufficient magnitude to constitute a risk of electric shock to humans.



The exclamation point within an equilateral triangle is intended to alert the users to the presence of important operating and maintenance (servicing) instructions in the literature accompanying the product.



**CAUTION: To reduce the risk of electric shock, do not remove the cover. No user-serviceable parts inside. Refer servicing to qualified service personnel.**

**WARNING: To prevent fire or electric shock, do not expose this equipment to rain or moisture.**

#### SAFEGUARDS

Electrical energy can perform many useful functions. This unit has been engineered and manufactured to assure your personal safety. Improper use can result in potential electrical shock or fire hazards. In order not to defeat the safeguards, observe the following instructions for its installation, use and servicing.

# Table of Contents

---

<b>INTRODUCTION</b>	<b>Product Overview.....4</b>
	<b>Front and Rear Panel Illustrations and Dimensions.....4</b>
<b>INSTALLATION</b>	<b>Unpacking.....6</b>
	<b>What is Included.....6</b>
	<b>Mounting.....6</b>
	<b>Connections:</b>
	<b>Balanced Audio Connector Pinouts.....7</b>
	<b>Unbalanced Audio Connector Pinouts.....8</b>
	<b>Audio Inputs and Outputs.....9</b>
	<b>RS-232 Port.....10</b>
	<b>System Requirements.....11</b>
	<b>Software Installation.....11</b>
<b>USE</b>	<b>Control, Indicator, and Connector Descriptions.....12</b>
	<b>General Use Guidelines.....14</b>
	<b>Presets.....15</b>
	<b>How to save presets into the DSP-30.....15</b>
	<b>How to recall Presets .....16</b>
	<b>Lockout feature use.....17</b>
	<b>Contact closure Feature .....18</b>
	<b>RS-232 pinout.....19</b>
	<b>Application Example.....20</b>
<b>SPECIFICATIONS.....22</b>	
<b>ARCHITECT'S &amp; ENGINEER'S SPECIFICATION.....24</b>	
<b>QSC INFORMATION</b>	<b>Maintenance, Warranty &amp; QSC Contact Information.....25</b>

*© Copyright 2002, QSC Audio Products, Inc.  
QSC® is a registered trademark of QSC Audio Products, Inc., Costa Mesa, CA  
"QSC" and the QSC logo are registered with the U.S. Patent and Trademark Office*

# Introduction: Overview and Illustrations

## Overview

The DSP-30 and Signal Manager software combine easy-to-use, customizable, two-channel DSP with simple operating-mode selection that requires only two buttons to operate. It can be used with all amplifiers and is housed in a 1-RU, 19-inch rack-mount steel chassis. Sampling frequency is 48 kHz, with 24-bit resolution. Dynamic range is greater than 93dB. It is absolutely rugged and dependable in the spirit of all QSC professional audio products and fully suited for the rigors of touring use.

Processing capabilities of the DSP-30 include compressors, limiters, delays, parametric EQ, high/low pass filters, high/low shelf filters, test signal generators (sine-wave, pink- and white-noise), splitters/mixers, polarity reversal, gain/attenuation, and metering. A feature called "Predictive Delay" enables the DSP-30's compressors and limiters to produce less signal distortion than their analog counterparts, especially for fast attack times. Predictive delay adds time delay to the signal path and must be accounted for to maintain proper time alignment. Using the Signal Manager software, predictive delay may be turned on or off; when on, it will provide time delay information to the operator.

The DSP-30 provides powerful signal processing while keeping operation as simple. Preset operating modes are user-selectable by scrolling through the list of numbered Presets on the front panel display and selecting. The DSP-30 will mute,

reconfigure, and unmute in a fraction of a second, providing smooth transitions free of thumps, clicks and other undesirable audio artifacts. The contact closure input feature allows for instantaneous gain changing and other programmable uses.

Use the QSC Signal Manager software to create the preset configurations. Please refer to page 11 for computer system requirements and software installation guidelines. For instructions for creating a simple signal processing chain, refer to the software help file. QSC's Signal Manager software provides an easy-to-use graphical user interface where DSP "objects" are placed onto a workspace and interconnects are drawn. This interface allows almost infinite configuration possibilities.

Signal Manager transfers the preset data to the DSP-30 through a serial data cable. The cable connects between the computer's COM port and the DSP-30's RS-232 port. Once the presets have been loaded, connection to the computer is no longer required. This feature allows essentially tamper-proof DSP setup. Stored presets can be recalled using the front panel Select button. Modification of stored presets, or the creation of new presets can be implemented by connecting a computer and loading the new presets into the DSP.

The DSP-30 will provide many years of reliable, professional quality signal processing. From all of us at QSC Audio Products, "Thank you."

## Front Panel

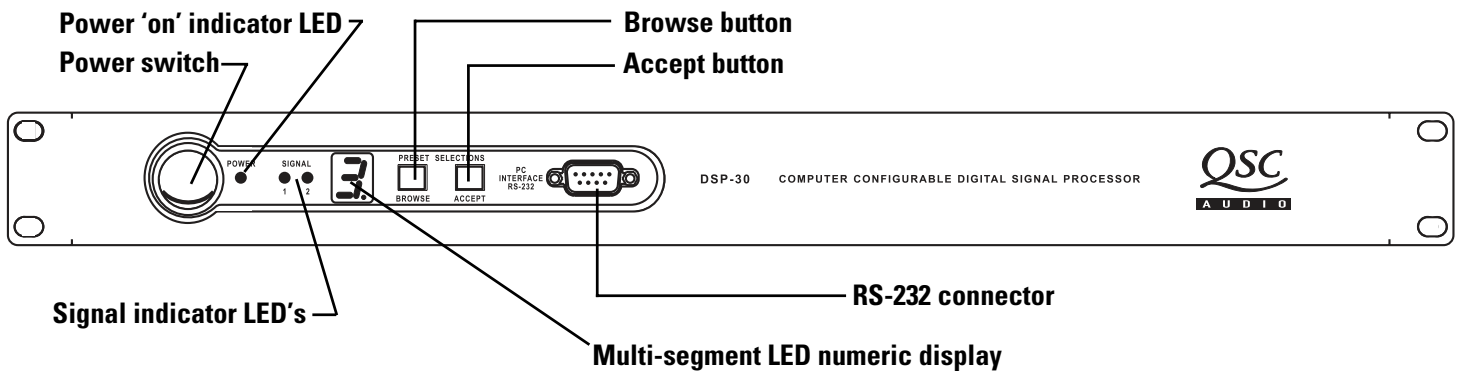

## Rear Panel

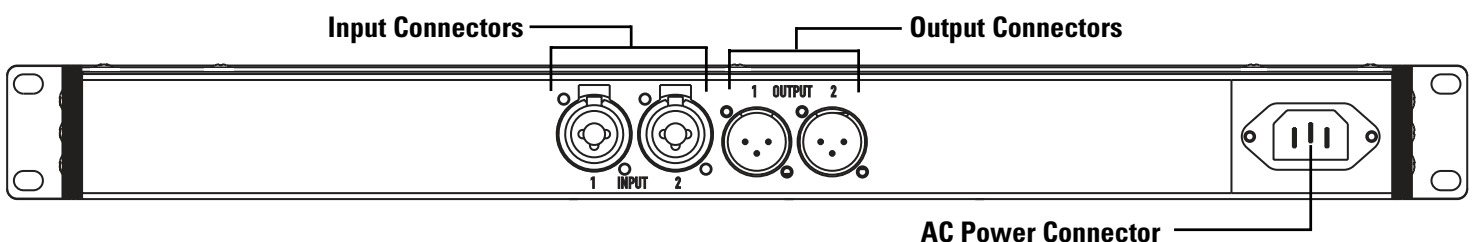

# Introduction: Illustrations and Dimensions

## Dimensions

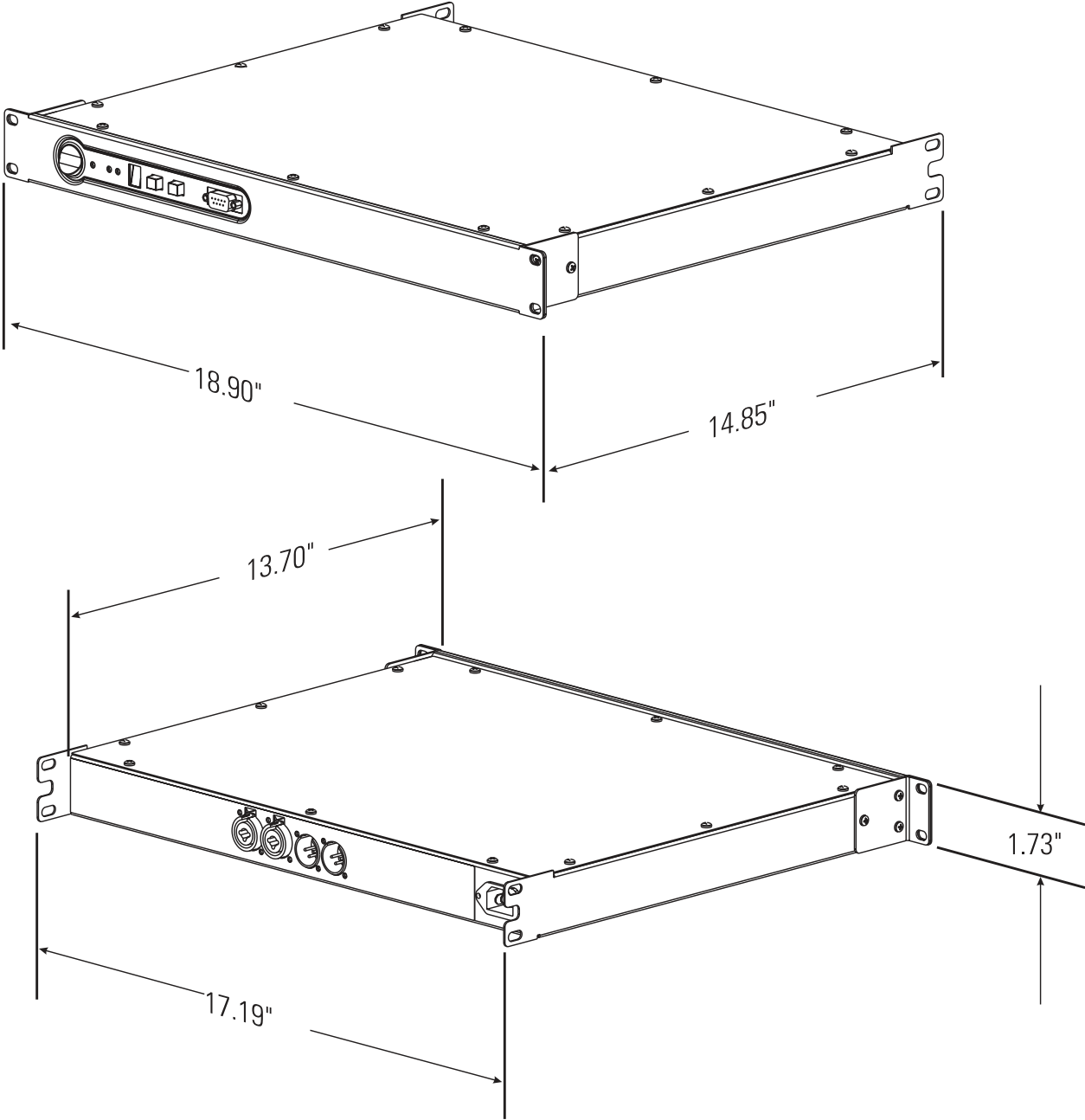

# Installation: Unpacking and Mounting

## Unpacking

There are no special unpacking precautions. However, it is recommended you keep the original packing material for reuse in the rare event that service be required. If service is required and the original packing material is not available, ensure that the unit is adequately protected for shipment (strong box of appropriate size , sufficient packing material to prevent load-shifting or impact damage).

### What is included in the carton:

<u>Item</u>	<u>Description</u>	<u>Quantity</u>
1-	DSP-30 Digital Signal Processor	1
2-	Self-adhesive rubber feet	4
3-	Hardware Manual (this document)	1
4-	Signal Manager Software CD	1
5-	IEC Power Cord 3 x #18 AWG	1
6-	RS-232 cable (6 ft.)	1

## Mounting

The DSP-30 can be used in or out of an equipment rack. Adhesive rubber feet are included for non-rack mount installations. Use them to prevent the unit from scratching or marring support surfaces.

## Rack Mounting

Rack mount the DSP-30 by supporting it from underneath while aligning the mounting holes with the threaded screw holes in the rails; install all four mounting screws and washers and tighten securely. Ensure use of all four mounting screws in order to minimize the chance of bending or distorting the rack mount ears. Rack mounting is optional.

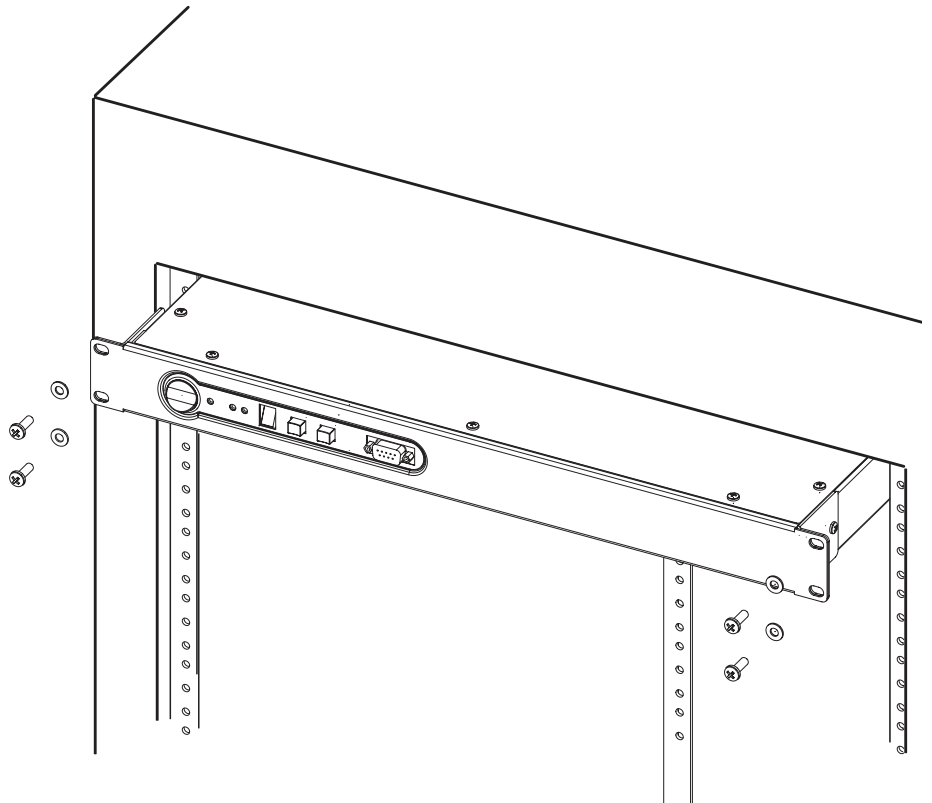

## Support the Rear for Portable/Mobile Installations

If the DSP-30 is to be transported while in a rack, we recommend supporting the rear of the chassis. This will help prevent the unit from being damaged from the increased mechanical stresses of portable and mobile use. The DSP-30's chassis includes integral rear mounting tabs for securing to the rack mounting ears.

# Installation: Balanced Audio Connections

## Connecting Audio Inputs and Outputs

All audio connections should be balanced to ensure the best performance. Unbalanced signals may be used if necessary; follow the wiring guidelines below for recommended unbalanced termination.

The audio input jacks are female 3-pin XLR/TRS "combo" connectors. They will accept male XLR plugs or TRS (tip-ring-sleeve) 1/4-inch phone plugs. The audio output jacks are male 3-pin XLR connectors.

### BALANCED

#### Balanced connection is recommended for all inputs.

The XLR - TRS "combo" inputs are electronically balanced. Balanced input cables are recommended to minimize noise pick up and prevent ground loops.

Refer to the pinouts provided (below) for proper connection.

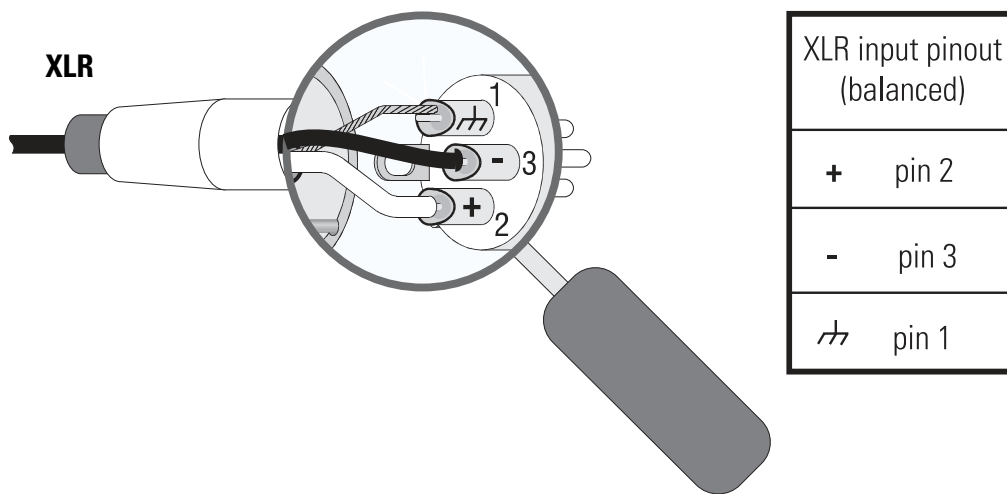

### TRS (1/4 inch)

TRS- tip, ring, sleeve (3 conductors)

**Suitable only for inputs.**

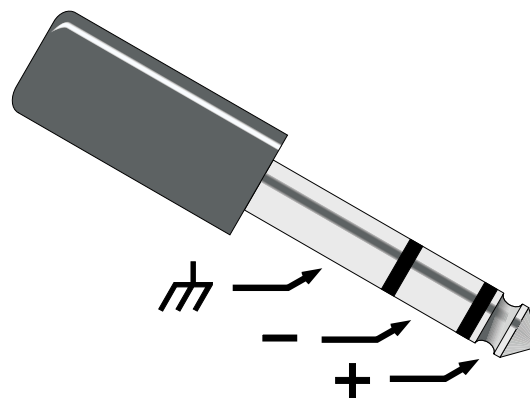

# Installation: Unbalanced Audio Connections

## Connecting Audio Inputs and Outputs

All audio connections should be balanced to ensure the best performance. Unbalanced signals may be used if necessary; follow the wiring guidelines below for recommended unbalanced termination.

The audio input jacks are female 3-pin XLR/TRS "combo" connectors. They will accept male XLR plugs or TRS (tip-ring-sleeve) 1/4-inch phone plugs. The audio output jacks are male 3-pin XLR connectors.

### UNBALANCED

**Unbalanced inputs can be used if required.** If unbalanced audio sources are used, it is preferable to use an appropriate audio transformer (or other unbalanced-to-balanced "converter") to provide a balanced input. If this is not possible, then it is recommended that the negative terminal and shield terminal be connected to one another with a jumper wire.

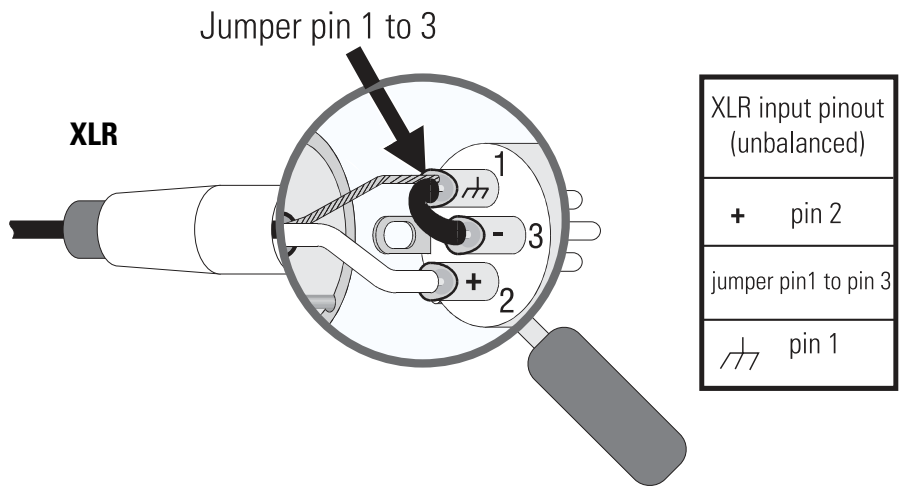

### TS (1/4-inch phone)

This style of plug automatically connects the negative terminal to shield when inserted in the jack.

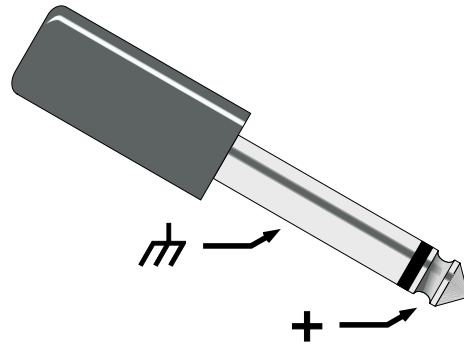

### TRS (1/4-inch)

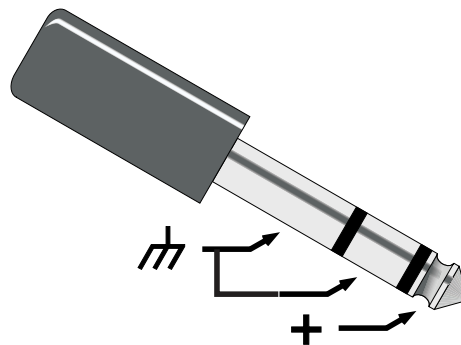

**NOTE for above abbreviations:** TRS- tip, ring, sleeve (3 conductors)  
TS- tip, sleeve (2 conductors)



# Installation: Connecting Audio Inputs and Outputs

## Audio Connections

Once the input and output cables have been properly wired, they can be connected to the receptacles on the rear panel of the DSP-30.

**INPUTS-** Input jacks are “combo” style. They accept either male XLR or 1/4-inch diameter TRS phone plugs. Plug line level audio source into the input jacks. Use balanced connections wherever possible.

**OUTPUTS-** Output jacks are male XLR style. They accept female XLR plugs. Connect the DSP outputs to the next audio device in the signal chain (this is usually a professional audio power amplifier). Use balanced connections wherever possible.

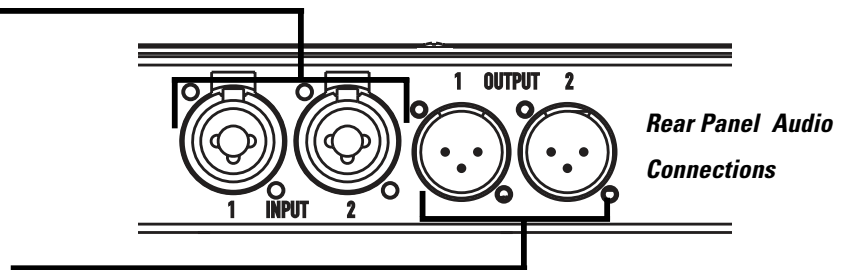

## Basic Audio Connections

The basic application shown is representative of most simple installations. The audio source outputs (console output, media player) are connected to the DSP’s input jacks. The audio program material is processed by the DSP and sent out the output jacks. Connect the DSP’s outputs to the next device’s input jacks. This next device is typically an audio power amplifier, but can be other signal-level devices, monitor busses, Ethernet audio devices, etc...

As with all professional audio installations, use balanced and fully shielded audio connections wherever possible. If connection to an unbalanced source is necessary, use an audio unbalanced-to-balanced converter (audio transformer or active-DI box) to properly isolate the source. If this is not possible, we recommend that the unused minus (-) terminal be connected to ground (the shield) in order to minimize noise.

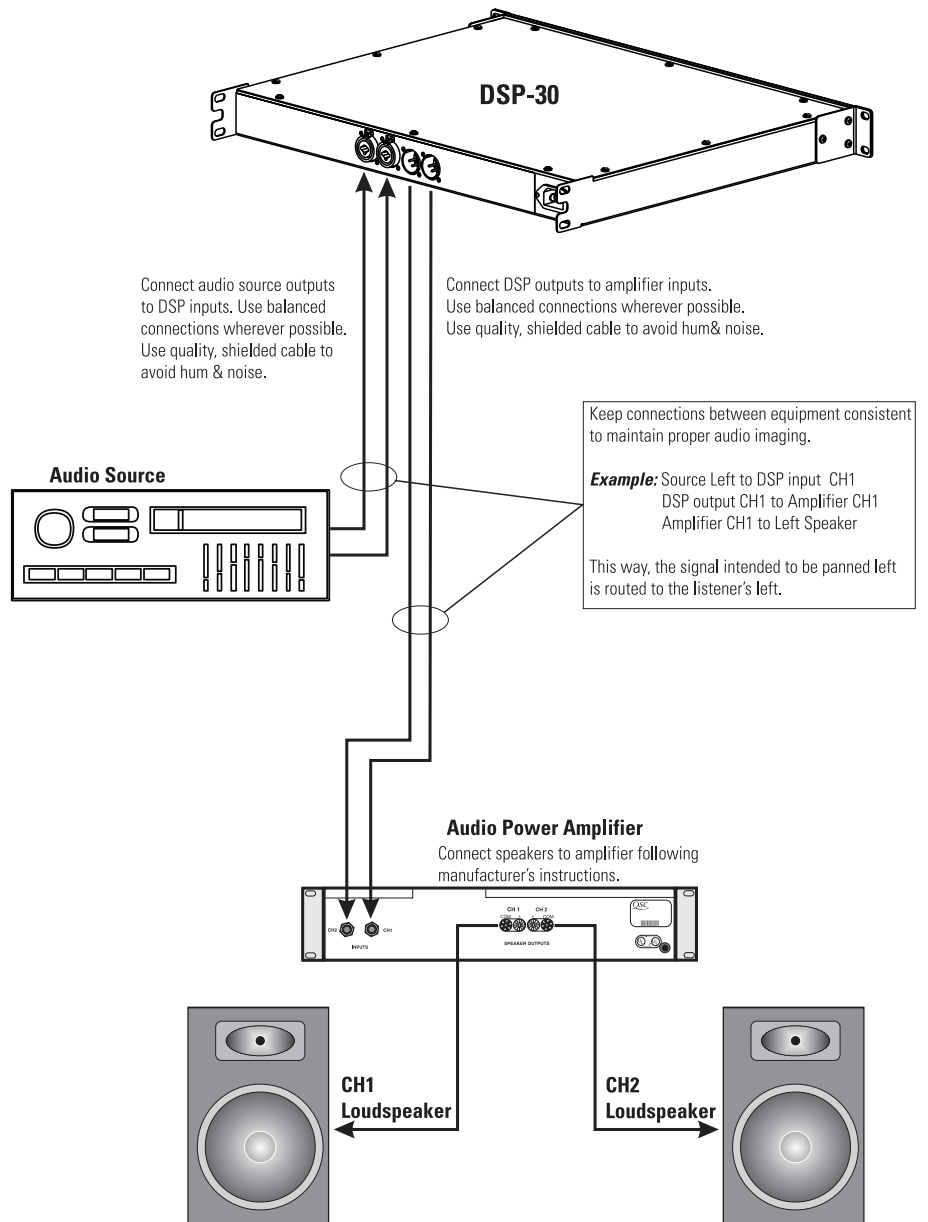

**NOTE! AC line cord omitted for clarity. Ensure AC power is properly connected.**

# Installation: Connecting to the RS-232 Port

---

## Connecting to the RS-232 Port

Connect to the RS-232 port using the 9-pin serial data cable (included in the shipping box). Orient the DB-9 plug correctly, insert the plug fully into the RS-232 port and finger-tighten the retaining screws. The cable length should be 25 feet or less. "Null-modem" type cables will NOT work.

Connection to the computer is required only while loading the presets into the DSP-30 or for "real-time" adjustments to a configuration before saving it as a Preset. Communication is established using the Signal Manager program. Refer to the software help file section, "RS-232 Communication" for the proper procedure and software/hardware settings that effect RS-232 communications.

DSP setup and programming takes place through the RS-232 port. Any time you need to load different presets, connect to the computer using the RS-232 port. If "real-time" control is required, the RS-232 port connection is required. If you do not need real-time control, then you can disconnect the serial port after loading the presets. The eight preset configurations will remain in memory and can be recalled by using the front panel buttons as described on page 16.

*RS-232 port connection*

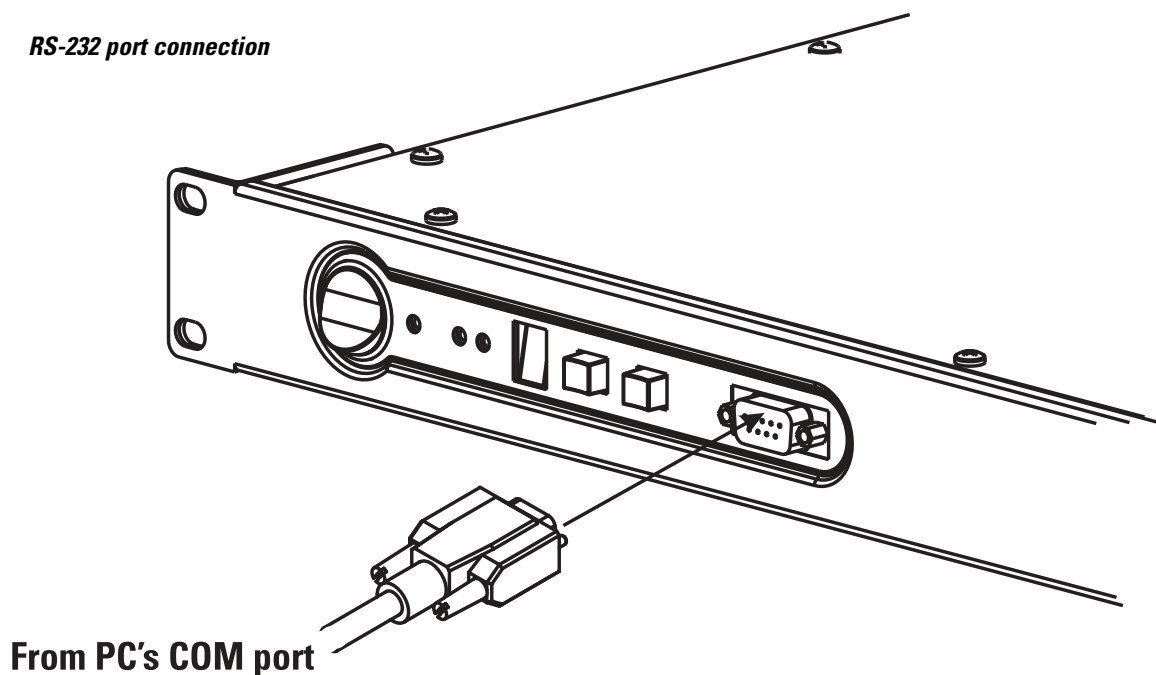

# Installation: System Requirements and Software Installation

---

The DSP-30 relies on the Signal Manager software for its DSP signal chains or configurations. You must use the supplied software to design your configurations and then load those configurations into the DSP-30 using a simple RS-232 connection. The DSP-30, as shipped from the factory, is configured to pass audio signals from input to output unaffected for all 8 presets. Use the software's Help System for instructions on how to use the Signal Manager software.

## System Requirements

To use the QSC Signal Manager software, you need the following:

- IBM compatible computer, 200 MHz or greater Pentium processor
- Windows 98/2000 or Windows NT 4.0 with Service Pack 6a or later
- SVGA display at 800 x 600 minimum resolution, 1024 x 768 recommended
- CD-ROM drive
- 32 MB or more of RAM
- 10 MB of free hard disk space
- An available RS-232 serial communications port (COM port) capable of 38.4k baud
- A male-to-female 9-pin serial cable (to connect the DSP to available COM port)

## Software Installation

1. Insert the *QSC Signal Manager* CD into your drive (typically drive "D:"). If your computer has AUTORUN enabled, the installation will start automatically after several seconds. **If it does not, then proceed to step 2, below. Otherwise, skip to step 3.**
2. Select **Run** from the Windows START menu. In the blank space, type "D:\setup.exe". Press "OK".
3. Follow the on-screen installation instructions.
4. After Signal Manager has finished installing, a "readme" file will automatically be displayed (by default). Please take the time to read this important information. It contains the most recent information about using the software and related issues.
5. To run the application, double-click the QSC Signal Manager icon that was placed on your desktop during install or select "Programs, QSC Signal Manager, Signal Manager" from the Start menu.
6. Refer to Signal Manager's on-screen help system for detailed instructions on creating configurations and general use information. Also visit QSC on the internet at <http://www.qscaudio.com> for DSP-related updates.
7. **IMPORTANT!** The DSP is shipped with all of its presets configured to pass full-range audio signals through both channels. ***THIS MAY NOT BE APPROPRIATE FOR YOUR SETUP! Be sure to configure any necessary crossovers, filters, etc. prior to applying audio signals to the inputs. Damage to equipment may result if these recommendations are not followed.***



- The last active Preset used when the unit is turned off becomes the active Preset again once the power is reapplied. This ensures that the system "comes up" just as it was left last time it was powered down.
- Do not run your amplifier "wide open" (maximum gain) while making real-time adjustments to the DSP's setup. The nature of the communication path between the PC and DSP is inherently more complex than direct physical controls of an equivalent analog processing device. Unpredictable results may occur due to failure of the PC or the communications channel. Under such circumstances, damage to your drivers is possible if the amplifier gain is set for high power levels. Use the minimum useful gain settings while making system adjustments.

# Use: Control, Indicator, and Connector Descriptions

## FRONT PANEL

**POWER** switch- This rocker switch turns the unit on by pressing the top side of the switch. Turn off by pressing the bottom side of the switch.

**POWER** indicator- This blue LED illuminates when the unit has power properly applied and the power switch is in the "On" position.

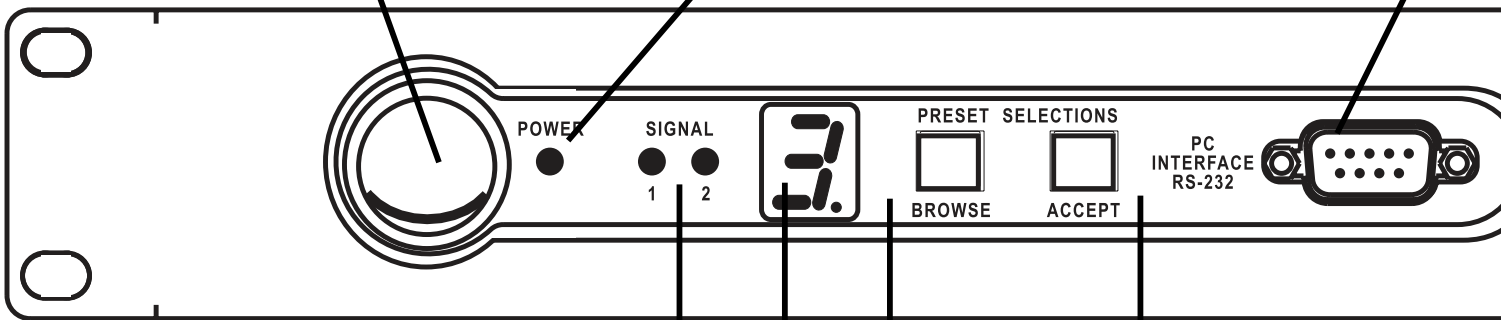

**SIGNAL**- These green LED's illuminate when the unit detects an input signal on each channel. Each channel's indicator operates independently. Dual brightness levels indicate signal level. At 40dB below clipping, they will light dimly; at 20dB below clipping, they will light brightly.

**NUMERIC DISPLAY**- This multi-segment numeric display indicates the preset selected. The decimal point after the number indicates "lock" mode when illuminated.

A steady display indicates the active preset number. A flashing display indicates the pending preset selection.

## REAR PANEL

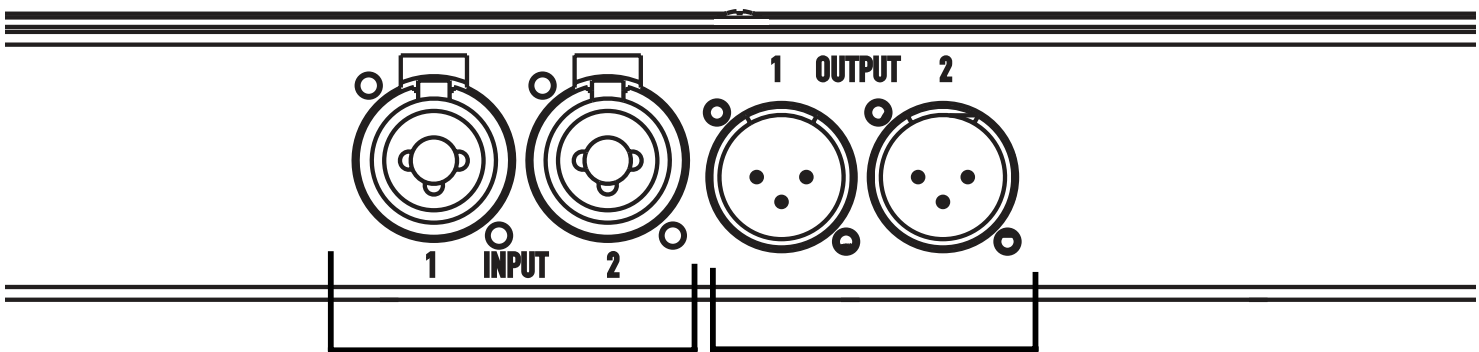

**CH 1 INPUT, CH 2 INPUT**- These female XLR-combo jacks are the line-level audio inputs to the unit. TRS or XLR connectors may be used.

They are electronically balanced with an input impedance of 8.3k Ohms. If used in an unbalanced configuration, the input impedance is 3.7k Ohms.

Input sensitivity is selectable in software.

**CH 1 OUTPUT, CH 2 OUTPUT**-- These male XLR outputs provide post-DSP (processed) signal from the unit. Connect the outputs to your amplifier's inputs (or other downstream device).

There is a software-selectable output pad that may be used to attenuate the output level.

## Use: Control, Indicator, and Connector Descriptions

**PC INTERFACE RS-232**- This DB-9 female jack is for attaching the serial cable between the unit and the computer. Use this connection for loading your DSP configurations from the computer to the DSP and for “real-time” configuration tuning with *Signal Manager* software.



### PRESET SELECTIONS buttons-

**BROWSE**- increments the Preset Memory and the Preset Number Display.

**ACCEPT**- after using the BROWSE button to choose a Preset number, press ACCEPT within 30 seconds to activate the selected Preset.



**NOTE!** Pressing the ACCEPT button and holding for at least 3 seconds locks (disables) the BROWSE key to prevent accidental operation. The ACCEPT key must be pressed again and held for at least 3 seconds to “unlock” the BROWSE button so that other presets may be accessed again.

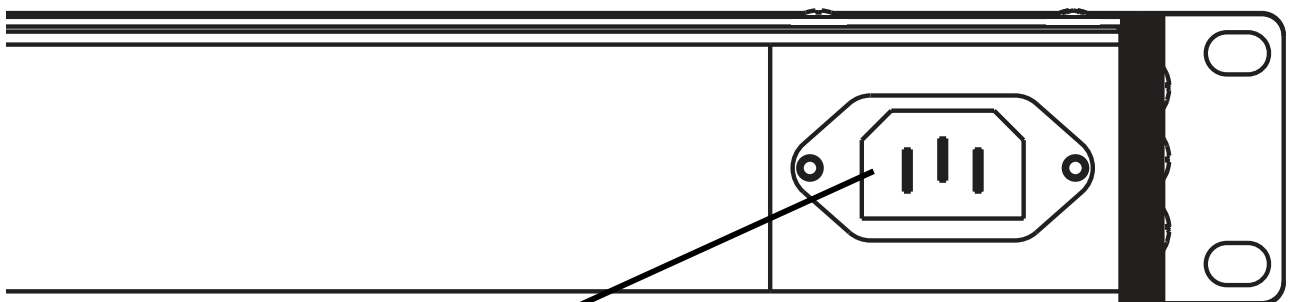

### AC power receptacle-

The DSP-30 uses a detachable IEC standard power cord for connecting to a grounded AC source. To connect power: identify the proper end of the cord, match the orientation of the receptacle on the rear panel and insert firmly into the receptacle. The power supply will accept from 100 to 240 Volts AC, 47 to 63 Hertz. Make sure the power cord used is suitable for the line voltage the unit is connected to. If a different type of IEC power cord is required, contact QSC's Technical Services Department to obtain the correct one.

# Use: General Use Guidelines and Preset Description

---

**IMPORTANT! Please read before operating this Digital Signal Processor with your audio system.**

## General Use Guidelines

This is a professional level DSP product that allows the user to produce virtually unlimited signal processor variations and configurations. Because of the infinite configuration possibilities of digital signal processing, it is possible to create configurations that may result in unwanted signals or uncontrollable output.

The Signal Manager software has no way of knowing if the DSP configuration you have designed will produce the results you intend. You can create signal loops in a configuration that may oscillate and damage your sound system if applied to the unit. When applying an untested configuration or when designing or experimenting with this unit, it is a very good idea to turn down the amplifier's physical gain controls. That way, you won't damage your speakers or create very loud sounds if you apply a configuration that doesn't do what you thought it would.

As a general rule, **DO NOT CREATE SIGNAL LOOPS!** Do not mix the output of a DSP object back into its own input! There is nothing useful to achieve by doing this, you will only create an oscillator that could damage your speakers. Also, **USE THE SINE AND NOISE GENERATOR OBJECTS WITH GREAT CAUTION!** These functions produce signals that can harm your speakers. Start with lowered gain settings. If you don't hear a signal when you think you should, **DO NOT INCREASE THE GAIN!!!** If the signal isn't audible at lower levels, there is something else wrong. Turning up the gain to full exposes you and your system to the possibility that some loose connection somewhere will suddenly send a full-amplitude signal through your sound system.

Like all freely configurable signal processing tools, this DSP will do what the configuration your design tells it to do, which may not be what you expect it to do, so use caution.

## Factory Presets



**NOTE! The factory setting for all eight presets is wire-through. Signals are passed from input to output without any processing. You may select configurations from the sample files (\*.cfg) within Signal Manager or create your own.**

## Use: Saving Presets Using QSC's Signal Manager software

---

### Presets



**The DSP-30 must be loaded with your desired presets using the Signal Manager program before use. Test all new presets for expected behavior at low power levels to avoid inadvertently damaging speaker systems.**

**The DSP-30 has eight Preset memories** numbered 1 through 8. Presets are DSP configurations saved to memory in the DSP. Only one preset may be active at one time. The possible configurations of the presets are essentially limitless. **You will need to configure the preset memories with signal chains that meet the precise requirements of your sound system using QSC's Signal Manager software. For help creating configurations, refer to the software's on-line Help system for detailed information.**

### Configuring the DSP-30's Presets

The DSP configurations created with the Signal Manager software are not usable until they are saved into the DSP. The software includes a collection of various sample configurations for your use. Modify and save them as your own configurations if they prove useful in your applications. You may also create your own to precisely fit your audio system. Once a configuration has been created and saved, it may be loaded into the DSP.

### How to Save Presets into the DSP-30

- 1-** Connect the DSP-30 to the PC using a 9-pin serial cable. Run the Signal Manager program. The preset configuration that is running in the DSP will be displayed on the Signal Manager workspace. It should match the front panel LED display of the DSP-30.
- 2-** You may now create a new configuration (or modify the existing one) to be saved as a DSP preset. To create a new configuration, select *Configuration/New* from the menu bar. This will clear the workspace and activate the DSP tools and filter icons. If a configuration already exists in the computer, choose the *Configuration/Open* menu item and select the desired configuration from the *Open* window. Note that in each of these cases, the Configuration Pane at the bottom of the workspace changes from reading 'ACTIVE' to 'EDIT.'
- 3-** After creating (or editing) your configuration and making the necessary parameter changes, select *Configuration/Save DSP Preset* from the menu bar. Then choose the Preset Identification Number that you wish to program. Press the OK button.
- 4-** Once the DSP is programmed with the configuration, the text banner at the top of the workspace will reflect the selected Preset Identification Number, as should the front panel LED of the DSP-30.



**NOTE! When programming presets into the DSP-30, be sure that the preset selected is the one you wish to overwrite. Once the configuration is applied to the DSP-30, the selected preset's previous information is overwritten.**

# Use: How to Recall a Preset from the Front Panel

## TO RECALL A PRESET-

1- Press the *BROWSE* key until the desired preset number shows in the display.

The selection display flashes until Step 2 (below) is completed.

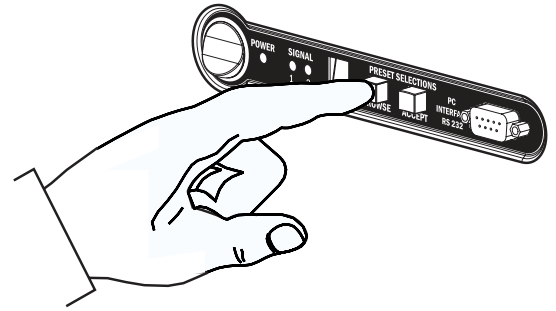

2- Press the *ACCEPT* key to activate the selected preset in the DSP.

Once the preset is active, the display will stop flashing.



**Note!** The *ACCEPT* button must be pushed within 30 seconds of selecting the preset. If a longer time passes, the DSP-30 will revert to its original preset.

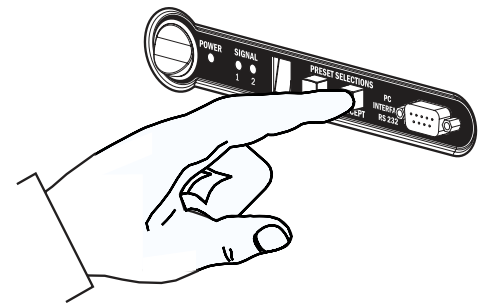

### Additional Tips:

- a) Recalling presets will typically be done without the use of a PC by using the Browse and Accept buttons on the front panel. However, a PC with Signal Manager software may be used if desired. Refer to the on-line Help file to learn more about this.
- b) Each preset can be dramatically different from one another. For that reason, when a preset is changed the outputs will mute, the DSP will be reconfigured, and then the outputs will unmute. This happens in fractions of a second. This ensures that undesired transients are minimized during preset changes. For live shows, this limits the changing of presets to pauses in the program material (like in between songs or sets).
- c) The front panel buttons can be 'locked' to prevent undesired operation. The next page describes how to do this.

### FRONT PANEL DISPLAY- Indications during preset operation and recall

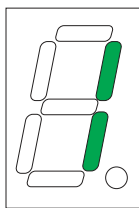

**Example- Preset 1 is active as indicated by the steady illumination of the display.**

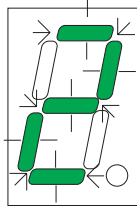

**Press BROWSE once and the display will increment to "2." The display will flash, indicating the ACCEPT button must be pushed to confirm the selection.**

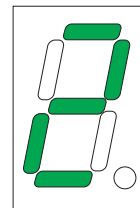

**Press ACCEPT once and the display will change from flashing to steady illumination. The ACCEPT button must be pushed within 30 seconds of preset selection.**



# Use: LOCK OUT Feature

## TO LOCK THE FRONT PANEL BUTTONS (Browse and Accept pushbuttons)-

- 1- Press the Accept button and hold it down for at least three seconds.
- 2- The "lock" indicator will illuminate.
- 3- The Browse button is disabled.

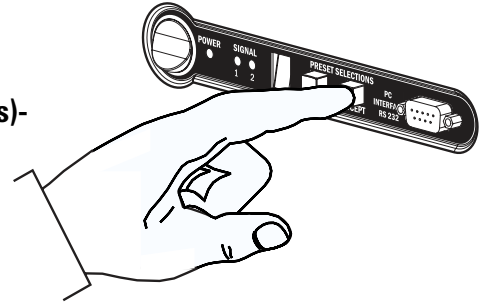

*Press the Accept button and hold for three seconds to lock/unlock the preset selection.*

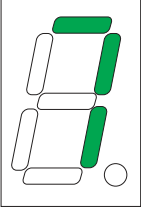
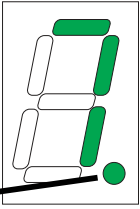
<b>FRONT PANEL DISPLAY-</b> <i>Example shows Preset 7 in "unlocked" and "locked" state.</i>	<b>UNLOCKED</b> 	<b>LOCKED</b> 
	<b>LOCK INDICATOR illuminated when locked</b>	

## TO UNLOCK FRONT PANEL BUTTONS-

- 1- Press and hold the Accept button for at least three seconds.
- 2- The Lock indicator will extinguish.
- 3- The Browse button is enabled.



Note: When the PC is communicating with the DSP-30, the LOCK INDICATOR will occasionally illuminate. This is normal and prevents commands from both the front panel and PC from interfering with one another.

# Use: Contact Closure Feature

## Contact Closure Feature

The contact closure feature is used to trigger gain changes in the DSP. Any configuration that uses one or more switched gain objects (see Signal Manager software Help file ) can take advantage of this feature. The contact closure will trigger all switched gain objects at once.



**All switched gain objects in a DSP configuration will be triggered by the one contact closure. It is not possible to trigger switched gain objects individually!**

## Wiring Diagram for Contact Closure

This feature requires the construction of a simple RS-232 cable (or through-adapter plug) that brings out pins 5 (GND) and 9 (contact closure trigger). These pins may be connected to a simple toggle or pushbutton switch that will be used to trigger a switched gain object in a DSP configuration. Refer to Signal Manager software Help file for available contact closure features.

### CONTACT CLOSURE CABLE PINOUT

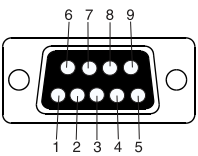

DB-9 Female plug to PC's COM port. Connection not required for contact closure feature.

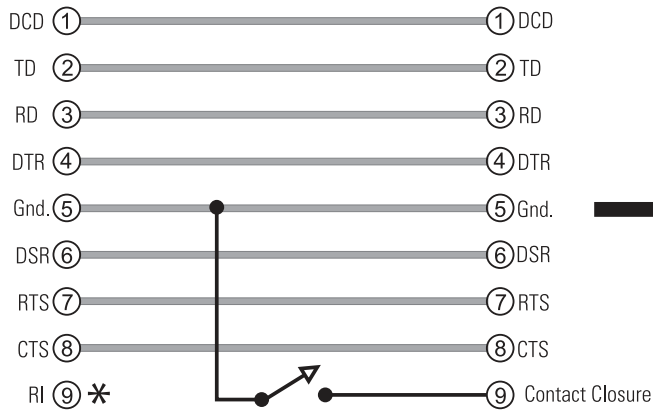

Contact Closure- can be toggle switch, pushbutton switch, relay contacts, limit switch contacts, and similar. TTL and CMOS logic levels supported.

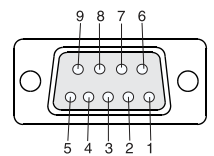

DB-9 Male plug to DSP-30

## Use: RS-232 Pinout

---

### RS-232 Pinout:

The diagram below shows the pin assignments for the female RS-232 connector on the DSP.

<u>Pin</u>	<u>Signal Description</u>
1	DCD
2	TD
3	RD
4	DTR
5	GND
6	DSR
7	RTS
8	CTS
9	Contact Closure

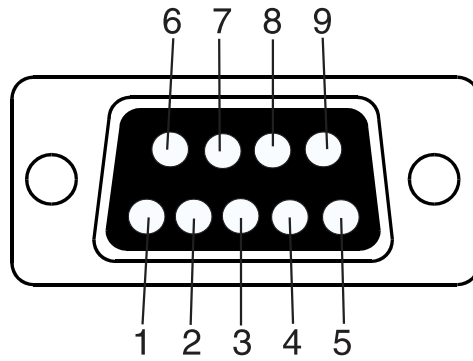

**\*Note!** Pin 9 is used for contact closure input. This pin is not normally used by RS-232 devices. Some laptop and desktop computer COM ports have been observed to "pull" pin 9 to ground; this will cause unexpected behavior of the contact closure function if pin 9 is not disconnected on the PC end of the cable. If this behavior is observed, make sure that pin 9 is disconnected on the PC end of the cable.

## Use: Application Example

---

### TRI-AMPED PA CABINETS WITH SUBWOOFER (refer to illustration at right)

This is highly generalized, but shows the main idea in creating larger systems. In this example, the audio source material is connected to the inputs of all four DSP's. Take care to keep right and left channel signals connected to the correct channels of downstream equipment. For example, keep all left channel signals routed through the channel 1 sections of downstream gear and all right channel signals routed through channel 2 sections of downstream gear. This preserves stereo imaging.

Each DSP would be setup independently with the appropriate crossover response and equalization for the specific driver being used. Refer to the speaker's (or driver's) documentation for recommended frequency range, drive level, and any other applicable information. In the example at right, DSP #1 (assigned to high frequency drivers) might be set up for a high pass filter with a -3dB point of 6 kHz and high-speed limiters to protect them from transients. DSP #2 (assigned to midrange drivers) might be set for a band pass filter, with -3 dB points at 1 kHz and 7 kHz using mild signal

limiting. DSP #3 (assigned to low frequency drivers) might provide a 45 Hz to 1100 Hz bandpass with EQ to remove modal resonances of the listening environment. DSP #4 (subwoofer drive) could be assigned a low pass filter with a -3dB point of 50 Hz and equalization as required. All the filters mentioned above would have assignable response type (where applicable) and assignable slope characteristics enabling precise tuning of the system.

Power requirements for high frequency drivers are generally much lower than for low frequency drivers; this requires either reduced gain in the signal processing stage or the lower power amplifier for the high frequency drivers. The opposite is true for the subwoofers; they generally require the highest power to drive them, so assign your most powerful amplifiers to the lowest frequency drivers. Assign your amplifiers to the drivers according to the required power levels .

# Use: Application Example

## TRI-AMPED PA CABINETS WITH SUBWOOFER: Sample Application Diagram

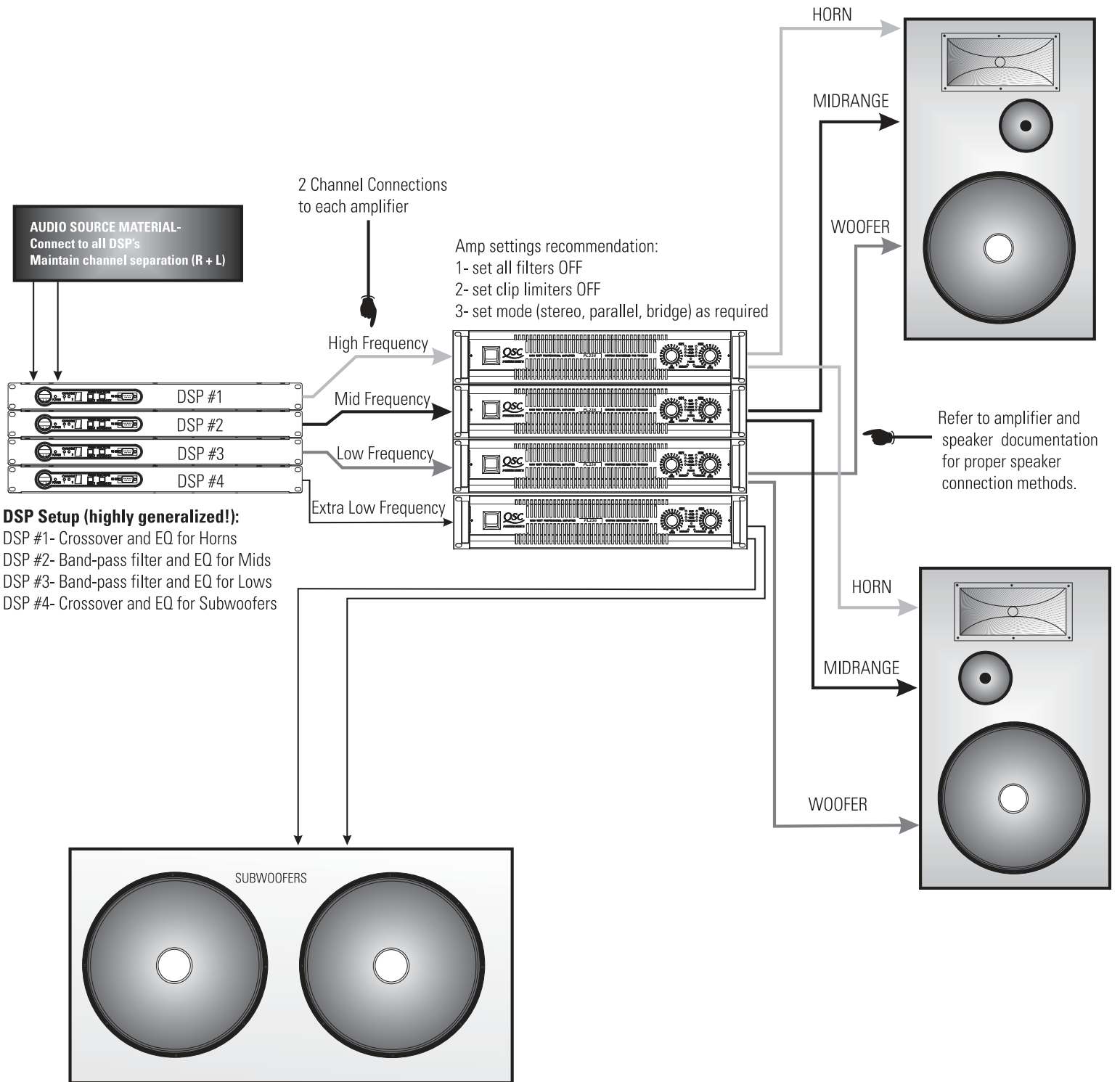

# Specifications

<b>Audio Converters</b>	24 bit, 48 kHz.
<b>Frequency response at 1dB below full scale input voltage</b>	20 Hz–20 kHz $\pm 0.4$ dB <b>(all sensitivities)</b>
<b>Distortion</b>	<0.007% THD+N @ 1dB below full scale output, all sensitivities, 20 Hz– 20 kHz
<b>Group Delay</b>	1.00 milliseconds
<b>Dynamic range AES-17 -60dB method</b>	>95dB unweighted, 1.5V, 4V and 9V input sensitivity >93dB unweighted, 18V input sensitivity
<b>Polarity</b>	In-phase or inverted
<b>Mute</b>	>95 dB attenuation
<b>Indicators</b>	Power: 1 blue LED Channel 1 and Channel 2 signal presence: 2 green LED's Preset Display: 7 segment LED

<b>Inputs</b>		<b>Outputs</b>	
Program inputs	2	Program outputs	2
Connector	3-pin female XLR -TRS 1/4" combo jack	Connector	3-pin male XLR receptacle
Type	Electronically balanced	Type	Electronically balanced
Grounding	All shield terminals connect to chassis	Grounding	All shield terminals connected to chassis
Input sensitivity (full scale input level)	Level and units are selectable in software interface	Output level (full scale)	Level and units are selectable in software interface
Impedance	8.3 K Ohm balanced 3.7 K Ohm unbalanced	Maximum Output	9.3 Vrms (+21.5 dBu)
Common-mode rejection	>54 dB, 20 Hz–20 kHz	Output Pad	-6dB
Crosstalk	>80 dB separation, 20 Hz–20 kHz	Output impedance	600 Ohms balanced

**Input/Output Termination: All XLR's: pin 2- hot (+), pin 3- cold (-), pin 1- ground / All 1/4" TRS: tip- hot, ring- cold, sleeve-ground**

## RS-232 Port

Port Description	RS-232, female, straight through
Cable Type	supplied: 9-pin serial cable, male-to-female (serial extension cable)
Maximum Cable Length	25 feet (7.6 meters)

## Contact Closure Input (sense)

Inputs	1 discrete input, TTL compatible, pin #9 of RS-232 port
Configuration	Single-ended input, pull LOW (to GND, pin 5) for closure detect
Resistance for closure detect	<150 Ohms
Resistance for open detect	>1.9 K Ohms
Maximum Voltage	+9 VDC

**Note: Specifications are subject to change without notice.**

# Specifications

## Signal Processing Capabilities

- Compressor** (RMS responding)
- Peak limiter** (peak responding)
- Parametric equalization**
- High and Low shelf Filter**
- High and Low pass Filter** (responses: Butterworth, Bessel, Linkwitz-Riley)
- Delay** (910 millisecond max., all delay objects, 20.83 microsecond increments)
- Signal level meter** (peak or RMS responding)
- Signal gain/attenuation** (with mute or bypass)
- Mixer** (2 to 1 mixer with *mute* and *lock channels* feature)
- Pink and white noise generator**
- Variable frequency tone (sinewave) generator**
- Contact closure input** (pin 9 of the RS-232 port can be pulled to ground (pin 5) for control purposes)

**8 programmable presets**

**RS-232 control**

**Signal splitter**

**Signal polarity selection**

## Gain Structure (balanced input and output)

Input Sensitivity Setting	Output Pad Setting	Input Signal Level (V <sub>rms</sub> , Full scale input)	Output Voltage	Resultant Gain
1.50 V.	Out	1.65 V <sub>rms</sub>	9.30 V <sub>rms</sub>	+15.0 dB
4.00 V.	Out	4.39 V <sub>rms</sub>	9.30 V <sub>rms</sub>	+6.5 dB
9.00 V.	Out	9.90 V <sub>rms</sub>	9.30 V <sub>rms</sub>	+0.5 dB
18.00 V.	Out	17.50 V <sub>rms</sub>	6.20 V <sub>rms</sub>	-9.0 dB
1.50 V.	In	1.65 V <sub>rms</sub>	4.70 V <sub>rms</sub>	+9.0 dB
4.00 V.	In	4.39 V <sub>rms</sub>	4.70 V <sub>rms</sub>	+0.5 dB
9.00 V.	In	9.90 V <sub>rms</sub>	4.70 V <sub>rms</sub>	-6.5 dB
18.00 V.	In	17.50 V <sub>rms</sub>	3.10 V <sub>rms</sub>	-15.0 dB

NOTE! Full scale output voltage of the DSP-30 is 9.30 Volts (rms)

## General

### Physical

Chassis Type	Steel (chassis & covers)
Height	1.73 inches
Width	18.9 inches (including rack ears)
Depth	14.9 inches (including rear ears) 13.7 inches (excluding rear ears)
Weight	9.5 lb. (4.3 kg) net 12.5 lb. (5.7 kg) shipping
Mounting	Stand-alone or rack mount
Operating temperature	0° to 50° Celsius

### Internal Power Supply

AC Input Voltage	100–240 VAC, autodetect
AC Input Current	0.3 Amps (rms) at 120 VAC
Frequency	40 to 63 Hz
Power Cord	
Recommended	IEC-type 3-conductor, #18 AWG

**Note: Specifications are subject to change without notice.**

# Architect's and Engineer's Specification

---

The Digital Signal Processor (DSP) shall provide two independent channels of DSP for signal delivery to all professional power amplifiers. Input and output sensitivity shall be adjustable to accommodate consumer and pro audio signal levels.

**Output Peak Limiter**—For each audio channel, the DSP shall provide a peak limiter that is assignable anywhere in the signal chain and can be bypassed. Its operation shall be based upon the peak signal level. The limiter shall provide the following adjustments:

- Gain
- Threshold
- Attack time
- Release time
- Predictive Delay

**High- and Low-Pass Filters**—For each channel of audio, the DSP will provide high-pass and low-pass filters that are assignable anywhere in the audio chain. The DSP shall provide the following crossover responses:

- Butterworth (6,12,18,24 dB per octave slope)
- Bessel (6,12,18,24 dB per octave slope)
- Linkwitz-Riley (12 & 24 dB per octave slope)

**High- and Low-Pass Shelf Filters**—For each audio channel, the DSP shall provide high-pass and low-pass shelf filters that are assignable anywhere in the audio chain. The shelf filters must be capable of being bypassed. The DSP shall provide the following shelf filter adjustments:

- Variable corner frequency
- Variable gain
- Variable slope

**Contact Closure I/O**—The DSP shall provide a trigger input usable for contact-closure (or other) purpose which shall be CMOS & TTL signal compatible.

**Compressor**-- The DSP shall provide a signal compressor that is assignable anywhere in the signal chain. It shall be based upon the RMS signal level. The compressor shall be capable of being bypassed. The compressor shall provide the following adjustments:

- Gain
- Threshold
- Attack time
- Release time
- Compression ratio
- Predictive Delay

**Power Supply**—The DSP shall be provided power from an internal power supply that operates from line voltages in the range of 100-240 VAC and frequencies from 40 to 63 Hertz. Line cord connection to the DSP shall be via an IEC-type line cord receptacle.

**Amplifier Interface**—The DSP shall connect to amplifiers using standard 3-pin XLR connections. Provisions for both balanced and unbalanced connection shall be provided.

**Noise & Tone Generation**-- The DSP shall provide pink and white noise generation capability. It shall also provide for user-specified tone generation. Level control of noise and tone objects shall be provided

**Presets**— The DSP shall be capable of storing eight preset configurations. Preset recall capability shall be via two front panel push-button switches and shall not require the use of a computer. The control software shall provide management of these presets.

**General**—All audio inputs and outputs shall be balanced. Audio input and output sensitivity shall be programmable using the control software. Units will be user-selectable from dBu, dBV and Volts (rms).

**Control**— The DSP shall be configurable via a front panel accessible RS-232 port.

The Digital Signal Processor shall be the QSC DSP-30.



# Maintenance, Warranty & QSC Contact Information

---

## Cleaning

The faceplate and chassis can be cleaned with a soft cloth and nonabrasive, mild cleaning solution. Products like Simple Green and Windex work well. Do not use powders or scrubbing pads of any type as they are usually abrasive and will permanently damage the finish of your DSP-30. Dampen a soft, lint-free cloth with the cleaning solution and wipe the unit down gently. Insure that cleaning solution does not get into the connectors. Do not spray the solution directly onto the unit as it will penetrate into the connectors.

## User Maintenance

There are no user servicable parts in the DSP-30. Contact QSC's Technical Services Department if service is required.

## Warranty Information

If the DSP-30 isn't working properly, please verify that a known good 9-pin serial cable is used between the DSP-30 and the computer for loading Presets. If proper operation can not be restored, the DSP-30 may require service. This must be performed by qualified service personnel. To obtain the location of your nearest QSC Authorized Service Center, please contact your QSC dealer or contact QSC's Technical Services Department.

## Disclaimer

QSC Audio Products, Inc. is not liable for any damage to speakers, amplifiers, or any other equipment that is caused by negligence or improper installation and/or use of this digital signal processor. QSC Audio Products, Inc. is not liable for any direct or indirect damage caused by computer communications failure.

## Product Warranty

QSC guarantees the DSP-30 to be free from defective material and/or workmanship for a period of three years from the date of sale, and will replace defective parts and repair malfunctioning products under this warranty when the defect occurs under normal installation and use—provided the unit is returned to our factory via prepaid transportation with a copy of the proof of purchase, such as a sales receipt. This warranty provides that examination of the returned product must indicate, in our judgment, a manufacturing defect. This warranty does not extend to any product which has been subjected to misuse, neglect, accident, improper installation, or where the serial number and date code have been removed or defaced.

If the DSP-30 is returned to the factory for service, it should be sent in the proper QSC carton. If you did not save the original carton, ask your QSC dealer for one or call QSC to have one sent to you. This warranty does not cover shipping damage caused by improper packing or the use of improper shipping cartons.



### WORLD WIDE WEB:

<http://www.qscaudio.com>



### TELEPHONE NUMBERS:

Main Number (714) 754-6175

Sales Direct Line (714) 957-7100  
or (800) 854-4079 toll free (U.S.A. only)

Technical Services (714) 957-7150  
or (800) 772-2834 toll free (U.S.A. only)



### FACSIMILE (FAX) NUMBERS:

Sales & Marketing FAX (714) 754-6174

Technical Services FAX (714) 754-6173



### ADDRESS:

QSC Audio Products, Inc.  
1675 MacArthur Boulevard  
Costa Mesa, CA 92626-1468 USA



**1675 MacArthur Boulevard Costa Mesa, California 92626 USA PH: (714) 754-6175 FAX: (714) 754-6174**

**© Copyright 2002, QSC Audio Products, Inc.**

**QSC® is a registered trademark of QSC Audio Products, Inc., Costa Mesa, CA  
"QSC" and the QSC logo are registered with the U.S. Patent and Trademark Office**