

EM Series EM15/EM150

User's Guide

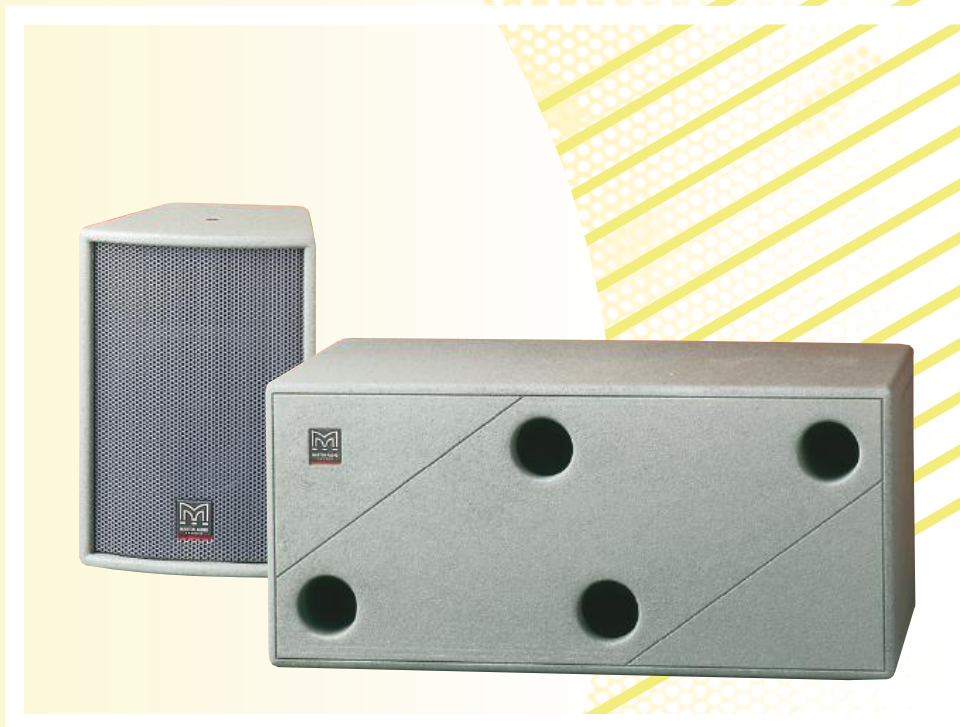

ENGLISH



The Martin Experience

CONTENTS (ENGLISH)		Page No
1	INTRODUCTION	2
2	UNPACKING	2
3	EM15 IMPEDANCE	3
4	SAFETY FIRST	4
4.1	Rigging and suspension	4
5	AMPLIFICATION	4
6	CONNECTING TO AN AMPLIFIER	5
7	SYSTEM CONFIGURATIONS	5
8	WARRANTY	7
9	TECHNICAL SPECIFICATIONS	8



The Martin Experience



This equipment conforms to the requirements of the EMC Directive 89/336/EEC, amended by 92/31/EEC and 93/68/EEC and the requirements of the Low Voltage Directive 73/23/EEC, amended by 93/68/EEC.

Standards Applied	EMC Emission	EN55103-1:1996
	Immunity	EN55103-2:1996
	Electrical Safety	EN60065:1993

1 INTRODUCTION

Thank you for purchasing a Martin Audio EM Series loudspeaker system. The EM15 is a miniature trapezoid full-range loudspeaker featuring twin 5"(125mm) drivers in a unique two-way configuration utilising patented ICT™ (Inductively Coupled Transducer) technology. The EM150 is a twin 10"(250mm) driver sub-bass system designed to be used to extend the low frequency performance of the EM15. It can also be used with larger EM Series enclosures such as the EM26.

Ideally suited to background and foreground music reproduction, the EM15 and EM150 are compact and easily installed. An external crossover is not necessary, but an EMX1A controller will increase the versatility of the complete system, adding relative level control and driver protection.

2 UNPACKING

Each Martin Audio loudspeaker is built to the highest standard and thoroughly inspected before it leaves the factory. After unpacking the system, examine it carefully for any signs of transit damage and inform your dealer if any such damage is found. It is suggested that you retain the original packaging so that the system can be repacked at a future date if necessary.

Please note that Martin Audio and its distributors cannot be held responsible for damage to any returned product through the use of non-approved packaging.

3 EM15 IMPEDANCE

The EM15 can be configured as either a 4 ohm or 16 ohm loudspeaker. The 16 ohm configuration allows up to 4 x EM15's to be run in parallel from a single amplifier channel. The EM15 is normally supplied from the factory in the 4 ohm configuration. To convert it to 16 ohms, follow the procedure below.

Fig 1

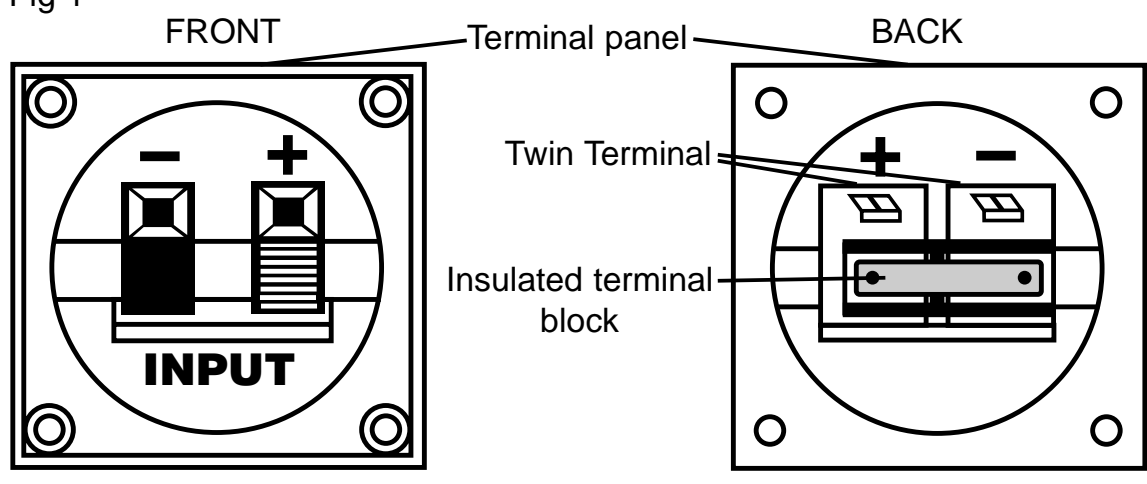

1. Remove terminal panel from rear of cabinet (4 pozi screws)
2. Remove red and black wires from the twin terminal, connect to each end of the insulated terminal block.
3. Replace terminal panel.

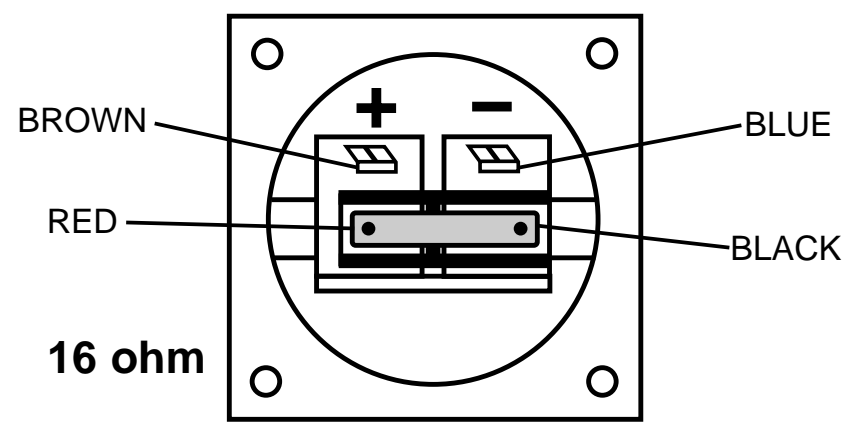
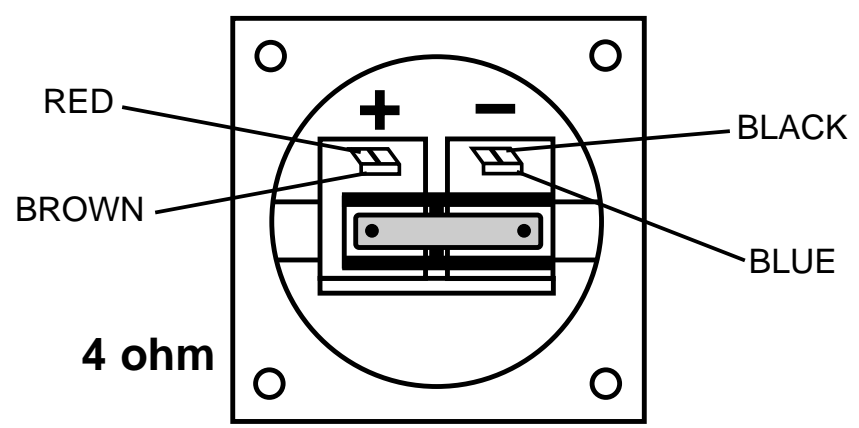

4 SAFETY FIRST

It is important that loudspeaker systems are used in a safe manner. Please take some time to review the following points concerning safe use of EM Series loudspeakers.

Professional loudspeakers are capable of producing extremely high sound levels and should be used with care. Hearing loss is cumulative and can result from levels above 90dB if people are exposed for a long period. Never stand close to loudspeakers driven at high level.

4.1 Rigging and suspension

WARNING: Suspending the system should only be done by qualified personnel following safe rigging practices. Secure fixings to the building structure are vital. Seek help from architects, structural engineers or other specialists if in any doubt.

5 AMPLIFICATION

The EM15 and EM150 are designed to be used with professional power amplifiers capable of producing the following power outputs into 4 ohms:

EM15 4 ohm	50-100W
EM15 16 ohm	200-400W
EM150	400-500W

Care should be taken to avoid amplifier clipping. It is important to understand that a low power amplifier driven into clipping is more likely to damage a loudspeaker than a higher power amplifier used within its ratings. This is because music signals have a high peak-to-average "crest" factor. When an amplifier is severely overdriven, its output waveform is clipped (its peaks are squared off) – reducing the crest factor. In extreme cases, the waveform can approach that of a square wave. An amplifier is normally capable of producing far more power under these conditions than its undistorted rated power output.

The use of very high power amplifiers with outputs greater than those recommended is discouraged.

Care should be taken to avoid switch-on surges, which can result in momentary power peaks in excess of specified ratings. When powering up a sound system it is important to switch on the amplifiers after the mixer and control electronics have stabilised. When powering down the system, reverse the sequence and switch off the amplifiers first.

6 CONNECTING TO AN AMPLIFIER

Connections are made via stripped wires to avoid the need for soldered connectors. The EM15 is provided with two spring-loaded terminals on the rear of the enclosure and the EM150 is provided with two pairs of 4mm screw terminals – a pair for each 10"(250mm) driver.

For mono EM150 operation these should be connected together externally in parallel: left Red (+) to right Red (+), left Black (-) to right Black (-). The paralleled mono impedance is 4 ohms. For stereo operation, separate connections should be made to the EM150's left and right terminals. The impedance in this case is 8 ohms left and 8 ohms right.

Note: It is important to maintain consistent polarity throughout i.e. Red to Red, Black to Black.

7 SYSTEM CONFIGURATIONS

The basic system configuration for one EM150 and up to six EM15's is shown in Fig 2. Up to three EM15's (each in 16 ohm configuration) are wired in parallel with the respective left and right inputs of the EM150, and driven from the left and right channels of the power amplifier. This arrangement presents a 3 ohm load to each amplifier channel. Alternatively, one EM150 may be used with a pair of EM26's, presenting a 4 ohm load to the amplifier.

Fig 2

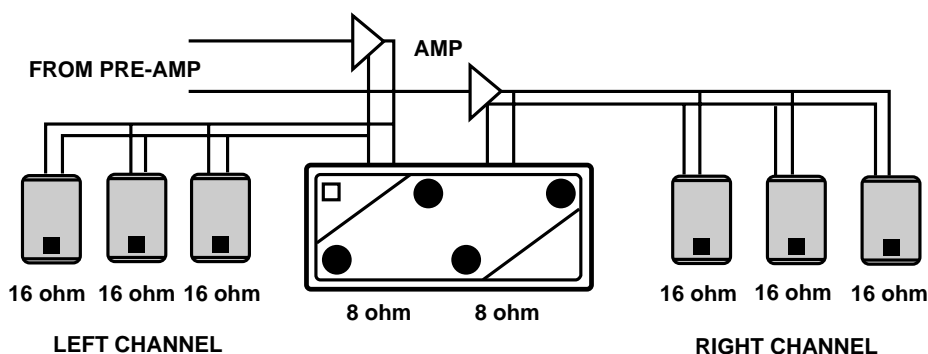

To allow for the addition of further EM15's and balance control between the EM15's and the EM150, a further power amplifier may be added to the system as shown in Fig 3. The same signal is fed into both amplifiers, one driving the EM15's, the other driving the EM150.

Fig 3

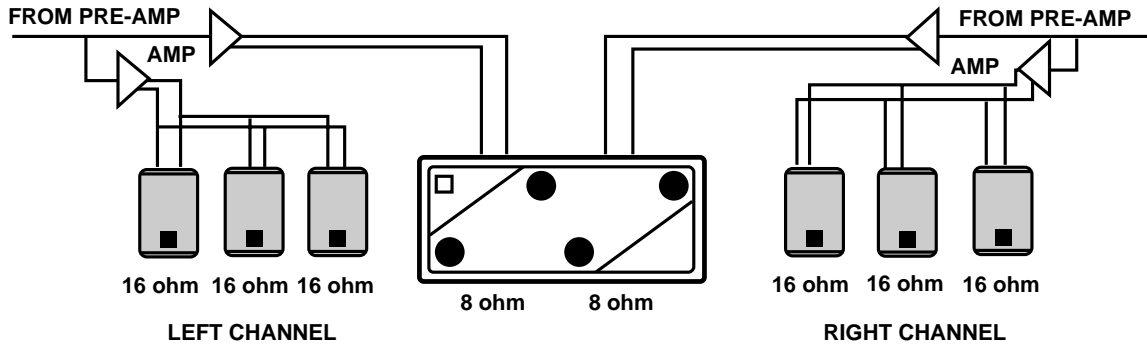

An EMX1A controller may be used to further increase the flexibility of the system (see Fig 4). With an EMX1A controller the relative levels can be balanced in the controller. The EMX1A also provides signal limiting for driver protection and has a 120Hz electronic crossover, removing signals below this point from the EM15's.

Fig 4

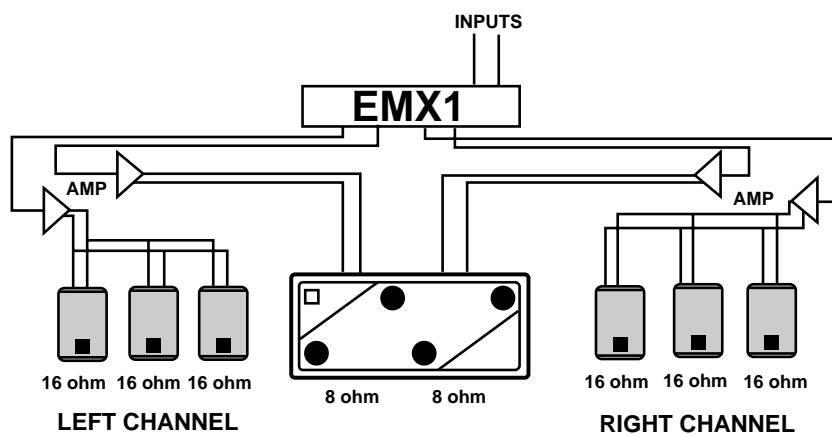

For larger systems, the EM150 drivers can be wired externally to give a 4 ohm mono sub. Two EM150's can now be used with an increased number of EM15's (see Fig 5).

Fig 5

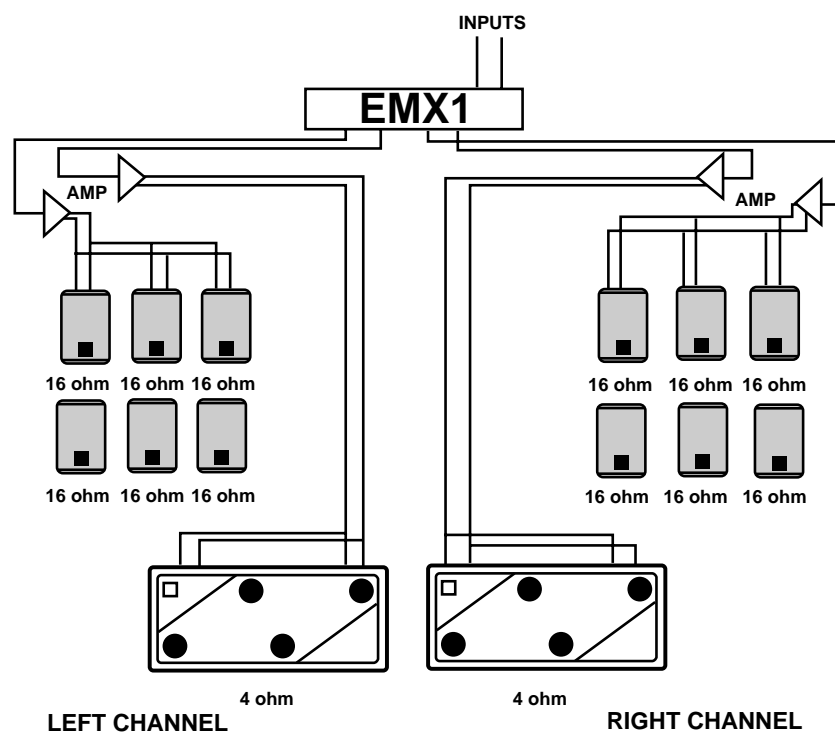

Note: Care must be taken, when connecting EM15's in parallel, to ensure that the total load impedance presented to the power amplifier will not exceed the minimum specified by the amplifier manufacturer.

8 WARRANTY

Martin Audio EM Series products are warranted against manufacturing defects in materials or craftsmanship over a period of 5 years from the date of original purchase. During the warranty period Martin Audio will, at it's discretion, either repair or replace products which prove to be defective provided that the product is returned in its original packaging, shipping prepaid, to an authorised Martin Audio service agent or distributor.

Martin Audio Ltd. cannot be held responsible for defects caused by unauthorised modifications, improper use, negligence, exposure to inclement weather conditions, act of God or accident, or any use of this product that is not in accordance with the instructions provided by Martin Audio. Martin Audio is not liable for consequential damages.

This warranty is exclusive and no other warranty is expressed or implied. This warranty does not affect your statutory rights.

9 TECHNICAL SPECIFICATIONS

EM15

TYPE	Ultra compact, two-way ICT™
FREQUENCY RESPONSE	120Hz-20kHz ±3dB
RATED POWER	75W AES, 300W peak
SENSITIVITY	91dB
MAXIMUM SPL	108dB continuous, 114dB peak
RECOMMENDED AMPLIFIER	50-100W (into 4 ohms)
DISPERSION	80 degs horizontal x 80 degs vertical
NOMINAL IMPEDANCE	4 ohms (16 ohms optional/user
configurable)	
BASS	5" (125mm)
HIGH FREQUENCY	5" (125mm) ICT™
ENCLOSURE	5 litres, rear vented
CONNECTOR	Spring-loaded
FITTINGS	M4 inserts for Omnimount 50
DIMENSIONS	(W) 172mm x (H) 282mm x (D) 172mm (W) 6.8ins x (H) 11ins x (D) 6.8ins
WEIGHT	5kg (11lbs)
SHIPPING DIMENSIONS	(W) 390mm x (H) 370mm x (D) 200mm (W) 15.4ins x (H) 14.5ins x (D) 7.9ins
SHIPPING WEIGHT	9kg (19.8lbs)
(Packed in pairs)	

EM150

TYPE	Ultra compact sub-bass system
FREQUENCY RESPONSE	45Hz-200Hz \pm 3db
RATED POWER	400W AES, 1600W peak (2 x 200W AES, 800W peak per driver)
SENSITIVITY	98dB
MAXIMUM SPL	123dB continuous, 129dB peak
RECOMMENDED AMPLIFIER	400-500W (into 4 ohms)
NOMINAL IMPEDANCE	2 x 8 ohms nominal stereo, 4 ohms nominal mono
BASS	2 x 250mm (10") extended throw
ENCLOSURE	91 litres, vented
CONNECTOR	2 x spring-loaded
DIMENSIONS	(W) 790mm x (H) 360mm x (D) 410mm (W) 31.1ins x (H) 14.2ins x (D) 16.1ins
WEIGHT	31kg (68lbs)
SHIPPING DIMENSIONS	(W) 950mm x (H) 390mm x (D) 450mm (W) 37.4ins x (H) 15.4ins x (D) 17.7ins
SHIPPING WEIGHT	34kg (75lbs)

NOTES (EM Series)

Sensitivity measured in half-space conditions at 1 metre with 1 watt input, using band limited pink noise. SPL measured at 1 metre using band limited pink noise.

Finish: Textured grey green paint.

Protective grilles: Perforated steel grey with 48% free air flow.

Due to our policy of continuous improvement all specifications are subject to change without notice.

EM Series EM15/EM150

 Please Click here to
return to main menu

 Please Click here to
visit our website



The Martin Experience

Century Point, Halifax Road, Cressex Business Park, High Wycombe, Buckinghamshire HP12 3SL, England.

Telephone: +44 (0)1494 535312 Facsimile: +44 (0)1494 438669

Web: www.martin-audio.com E-mail: info@martin-audio.com

All material © 2007. Martin Audio Ltd. Subject to change without notice.