

D-Show™ Guide

Version 2.0

Digidesign

2001 Junipero Serra Boulevard
Daly City, CA 94014-3886 USA
tel: 650-731-6300
fax: 650-731-6399

Technical Support

Digidesign (USA)

tel: 650-731-6100
fax: 650-731-6384

Product Information (USA)

tel: 650-731-6102
tel: 800-333-2137

International Offices

Visit the Digidesign Web site
for contact information

Web Site

www.digidesign.com



digidesign

Copyright

©2006 Avid Technology, Inc. All rights reserved. This guide may not be duplicated in part or in whole without the prior written consent of Avid Technology, Inc.

Avid, Digidesign, D-Show, and Pro Tools are trademarks or registered trademarks of Avid Technology, Inc. in the U.S. and/or other countries. All other trademarks contained herein are the property of their respective owners.

Product features, specifications, system requirements, and availability are subject to change without notice.

PN 9106-55032-00 REV A 03/06

WARNING

This product contains chemicals, including lead, known to the State of California to cause cancer and birth defects or other reproductive harm. Wash hands after handling.

Communications & Safety Regulation Information

Compliance Statement

The models D-Show Main, D-Show Sidecar, D-Show FOH Rack, and D-Show Stage Rack comply with the following standards regulating emissions and immunity:

- FCC Part 15 Class B
- EN55103 – 1, environment E3
- EN55103 – 2, environment E3
- AS/NZS 3548 Class B
- CISPR 22 Class B
- ICES-003 Class B

Canadian Compliance Statement:

This Class B digital apparatus complies with Canadian ICES-003
Cet appareil numérique de la classe B est conforme à la norme NMB-003 du Canada.

CE Compliance Statement:



Digidesign is authorized to apply the CE (Conformité Européenne) mark on this compliant equipment thereby declaring conformity to EMC Directive 89/336/EEC and Low Voltage Directive 73/23/EEC.

Australian Compliance:

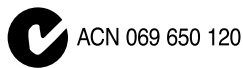

Radio and Television Interference

This equipment has been tested and found to comply with the limits for a Class B digital device, pursuant to Part 15 of the FCC Rules.

Communications Statement

This equipment has been tested to comply with the limits for a Class B digital device. Changes or modifications to this product not authorized by Digidesign, Inc., could void the Certification and negate your authority to operate the product. This product was tested for CISPR compliance under conditions that included the use of peripheral devices and shielded cables and connectors between system components. Digidesign recommends the use of shielded cables and connectors between system components to reduce the possibility of causing interference to radios, television sets, and other electronic devices.

Safety Statement

This equipment has been tested to comply with USA and Canadian safety certification in accordance with the specifications of UL Standards: UL60065 7th /IEC 60065 7th and Canadian CAN/CSA C22.2 60065:03. Digidesign Inc., has been authorized to apply the appropriate UL & CUL mark on its compliant equipment.

Warning



Important Safety Instructions

- 1) Read these instructions.
- 2) Keep these instructions.
- 3) Heed all warnings.
- 4) Follow all instructions.
- 5) Do not use this apparatus near water.
- 6) Clean only with dry cloth.
- 7) Do not block any ventilation openings. Install in accordance with the manufacturer's instructions.
- 8) Do not install near any heat sources such as radiators, heat registers, stoves, or other apparatus (including amplifiers) that produce heat.
- 9) Do not defeat the safety purpose of the polarized or grounding-type plug. A polarized plug has two blades with one wider than the other. A grounding type plug has two blades and a third grounding prong. The wide blade or the third prong are provided for your safety. If the provided plug does not fit into your outlet, consult an electrician for replacement of the obsolete outlet.
- 10) Protect the power cord from being walked on or pinched particularly at plugs, convenience receptacles, and the point where they exit from the apparatus.
- 11) Only use attachments/accessories specified by the manufacturer.
- 12) Use caution when replacing the Lithium battery in the FOH Rack unit. There is danger of explosion if battery is incorrectly replaced. Replace only with the same or equivalent type.
- 13) Unplug this apparatus during lightning storms or when unused for long periods of time.
- 14) Refer all servicing to qualified service personnel. Servicing is required when the apparatus has been damaged in any way, such as power-supply cord or plug is damaged, liquid has been spilled or objects have fallen into the apparatus, the apparatus has been exposed to rain or moisture, does not operate normally, or has been dropped.

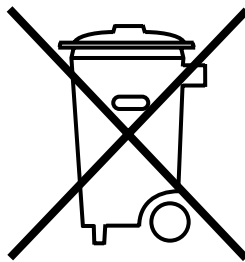

This symbol on the product or its packaging indicates that this product must not be disposed of with other waste. Instead, it is your responsibility to dispose of your waste equipment by handing it over to a designated collection point for the recycling of waste electrical and electronic equipment. The separate collection and recycling of your waste equipment at the time of disposal will help conserve natural resources and ensure that it is recycled in a manner that protects human health and the environment. For more information about where you can drop off your waste equipment for recycling, please contact your local city recycling office or the dealer from whom you purchased the product.

Contents

Part I Overview and Installation

Chapter 1. D-Show System Introduction	3
D-Show Features	3
D-Show Expansion Options	3
D-Show System Components	4
Operational Requirements	5
Connection Requirements	5
Compatibility Information	5
Chapter 2. Configuring and Connecting D-Show	7
Determining Control Surface Layout	7
Connecting D-Show Components	9
Connecting a Second Stage Rack	12
Power Connections	13
Audio and MIDI Connections	13
Control Surface Connections	18
Powering Up the System	19
Powering Down the System	19
Restarting the System	19
Setting the System Clock	19
Enabling a Second Stage Rack	19

Part II System Description

Chapter 3. D-Show Control Surface Overview	23
D-Show Main Unit and Sidecar Top Panels	23
Input Channels and Faders	24
Assignable Channel Section (ACS)	28
Assignable Output Encoders	29
Assignable Output Faders	30
Master and Global Controls	31
Meter Bridge	32
Trackball and View Mode Controls	32

Chapter 4. Basic Commands and Modes	33
Control Overview	33
Config Mode and Show Mode	34
Global Modifier Switches	34
Software Screen Pages and Tabs	35
Chapter 5. Navigating and Selecting Channels	39
Banking Input Channels and FX Returns	39
Banking Graphic EQ Frequency Bands	40
Banking the Assignable Output Encoders and Assignable Output Faders	40
Selecting and Targeting Channels	41
Targeting Plug-In Inserts	42
Screen Controls and Shortcuts	43
Chapter 6. Options	47
Overview of Options	47
System Configuration	47
Devices	50
Other D-Show Options	50

Part III Signal Routing

Chapter 7. Inputs and Input Routing	59
Configuring Inputs	59
Assigning Inputs to Channels	61
Routing Channels To Busses	61
Routing Inputs to Direct Outputs	62
Using Built-In Dynamics and EQ	62
Using Inserts on Channels	63
Using Input Direct	64
Adjusting Input Controls	64
Chapter 8. Outputs and Output Routing	69
Configuring Outputs	69
Routing Busses to Hardware Outputs	71
Routing Group Outputs to the Main Busses	71
Using Inserts on Output Busses	72
Inserting the Built-In Graphic EQ on Output Busses	73
Adjusting Output Controls	74
Adjusting Main Bus Controls	75
Monitoring the Main Mix	76
Direct Outputs	76
Matrix Mixers	77
Personal Q Mixers	77
Assigning and Using VCAs	77

Chapter 9. Groups	79
Configuring Group Busses	79
Assigning Inputs to Group Busses	79
Managing Group Bus Assignments	79
Group Bus Signal Flow Options	80
Adjusting Group Bus Output Controls	81
Routing Group Bus Outputs to the Main Busses	81
Routing Group Busses to Direct Outputs	81
Using Inserts on Group Bus Outputs	81
Inserting the Built-In Graphic EQ on Group Bus Outputs	81
Simple and Expert Operational Modes	82
Chapter 10. Auxes and Variable Groups	83
Configuring Aux Busses and Variable Group Busses	83
Assigning Inputs to Aux Busses and Variable Group Busses	86
Managing Aux Bus and Variable Group Bus Assignments	86
Aux Bus and Variable Group Bus Signal Flow Options	88
Adjusting Aux Bus and Variable Group Bus Output Controls	89
Routing Aux Busses and Variable Group Busses to Direct Outputs	90
Using Inserts on Aux Bus and Variable Group Bus Outputs	90
Inserting the Built-In Graphic EQ on Aux Bus and Variable Group Bus Outputs	90
Chapter 11. Matrix Mixers and PQ Mixers	91
Matrix Mixers	91
Personal Q Mixers	92
Configuring Matrix and PQ Mixers	92
Adjusting Matrix Mixer and PQ Mixer Input Controls	93
Adjusting Matrix Mixer and PQ Mixer Output Controls	95
Using Inserts on Matrix and PQ Mixer Outputs	95
Inserting the Built-In Graphic EQ on Matrix and PQ Mixer Outputs	95
Working with a PQ Controller	96
Chapter 12. Patchbay	97
Accessing the Patchbay	97
Overview of the Patchbay	97
Navigating the Patchbay	99
Routing Channels in the Patchbay	100
Warning when Stealing Inputs or Outputs in the Patchbay	102
Chapter 13. Metering	103
Channel Meters	103
ACS Section Dynamics Meters	104
Meter Bridge	105
Metering Options	107

Chapter 14. Solo and Monitor Busses	109
Solo Bus Modes	109
Solo Operation Options	110
Solo Bus Operation	111
Solo Safing Channels	112
Monitor Bus Operation	112
Talkback, 2-Track and Oscillator Controls	114
Chapter 15. Muting and Mute Groups	119
Muting	119
Mute Groups	120

Part IV Processing

Chapter 16. Dynamics	125
Built-In Compressor/Limiter	125
Built-In Expander/Gate	126
Channel Modes Affecting Dynamics	127
Adjusting Dynamics	127
Dynamics Settings and Presets	129
Side-Chain Keys and Filters	130
Chapter 17. EQ	133
Built-In EQ Parameters	133
Channel Modes Affecting EQ	134
Adjusting EQ	135
Graphic EQ for Outputs	137
Plug-In Mapping of EQ Controls	138
EQ Settings and Presets	138
Chapter 18. Hardware Inserts	141
Connecting External Effects Units	141
Assigning Hardware Inserts to Channels	142
Assigning Hardware Inserts from the Patchbay	143

Chapter 19. Plug-Ins	145
Installing and Authorizing Plug-Ins	145
Overview of Plug-Ins	148
Plug-In Racks	149
Rack Slots	151
Assigning and Routing Plug-Ins	152
Adjusting Plug-Ins	155
Adjusting EQ and Dynamics Plug-Ins from the ACS	157
Plug-In Presets and Snapshots	157
Plug-In DSP Usage	159
Plug-In Levels	159
Plug-In Latency and Processing Delay	159

Part V Shows

Chapter 20. Shows and File Management	163
Creating Shows	163
Loading Shows	164
Working with Presets	165
Transferring Settings, Shows and Presets	167
Undoing Changes Using the History Feature	168
 Chapter 21. Snapshots	169
Snapshots Page	169
Snapshot Controls on the D-Show Control Surface	171
Snapshots List	172
Creating Snapshots	173
Recalling Snapshots	174
Recall Safe and Channel Automation Safe	175
Managing Snapshots	179
Making Changes to Snapshots	180
Preview Mode	182
Undoing Snapshot Commands	184
Disabling Snapshots	185
Adding MIDI Messages to Snapshots	185
Adding Plug-In Data to Snapshots	186
Snapshot Options	187
Snapshot Data Types and Parameters	189
 Chapter 22. Synchronization	191
Automating Recall of Snapshots with MIDI Time Code	191
Remote Control of Snapshot Recall	193
Triggering of External Devices on Snapshot Recall	194
Sending MIDI Messages on Snapshot Recall	194
Synchronizing with Word Clock and Digital Audio Input	194

Chapter 23. Using the D-Show Standalone Software	195
System Requirements	195
Installing the D-Show Standalone Software	195
Simulating a D-Show Configuration	196
Transfer and Filing Quick Start	196
Exporting Patchbay Names to Text	198

Part VI Specifications

Chapter 24. Mechanical Specifications	201
Chapter 25. Audio Specifications	205
D-Show Console	205
Stage Rack	205
FOH Rack	206
Main Unit	208
Snake	208
Chapter 26. Signal Flow Diagrams	209
D-Show Input Signal Flow Diagram	209
D-Show Output Signal Flow Diagram	210
Chapter 27. Troubleshooting	211
Problem Solving	211
In Case of System Failure	213
Restarting D-Show	215
Resetting Hardware Components	216
Using the System Restore CD to Update or Restore the System	216
Main Unit and Sidecar System LEDs	217
Meter Bridge Status Indicators	218

Part VII Reference

Chapter 28. Control Surface Reference	223
D-Show Main Unit	223
D-Show Sidecar	226
Chapter 29. FOH Rack Reference	229
FOH Rack Front Panel	229
FOH Rack Back Panel	230
FOH Link Cable	232

Chapter 30. Stage Rack Reference	235
Stage Rack Front Panel	235
Stage Rack Back Panel	238
 Index	 239

Part I: Overview and Installation

Chapter 1: D-Show System Introduction

Welcome to the D-Show™ live sound mixing console from Digidesign®. D-Show is part of Digidesign's modular VENUE live sound environment.

D-Show offers an expandable console architecture, a flexible I/O scheme, powerful digital processing, plus options for integrated Pro Tools recording and artist-controlled monitor mixing.

D-Show Features

Control Features

- 24 bankable input channel strips, each with a touch-sensitive fader and two multi-purpose assignable rotary encoders
- Built-In High-Pass Filter, Dynamics and EQ processors on each Input channel strip
- Level meters on each input channel strip
- Assignable Channel Section (ACS) with dedicated Bus Assign, Aux Send, Direct Output, EQ and Dynamics controls
- 8 multi-purpose Assignable Output Encoders, with solo, mute and select controls
- 8 multi-purpose, touch-sensitive Assignable Output Faders, with solo, mute and select controls
- Up to 24 31-band Graphic EQs available for use on Output busses
- Main Busses configurable as Left–Center–Right or Left–Right+Mono

I/O Features

Stage Rack

- Up to 48 inputs on each Stage Rack, with remotely controllable mic preamps and individually selectable Phantom Power
- Up to 48 outputs on each Stage Rack

FOH Rack

- 8 channels of analog I/O for connecting outboard equipment
- 2-channel analog/digital I/O for 2-track feed or playback
- 2-channel analog near-field monitor system outputs
- Intercom mic input
- 16 channels of MIDI I/O
- Word clock I/O for integrating external digital devices

Control Surface

- Talkback mic input
- Headphone output

D-Show Expansion Options

The following options may be added to a D-Show system. For details on D-Show expansion and customization options, visit the Digidesign Web site (www.digidesign.com).

Control Surface

Sidecars Up to 3 Sidecars (each with 16 input channel strips) can be connected to the Main Unit for a total of 56 bankable input channel strips.

Stage Rack

Expanded Stage Rack I/O Each Stage Rack can be expanded up to 6 input cards and 6 output cards, for a total of up to 48 inputs and up to 48 outputs.

Additional Stage Rack A second Stage Rack can be added for a total of up to 96 inputs or up to 96 outputs. (A second Stage Rack requires an additional FOH Snake card be installed in the FOH Rack.)

Redundant Digital Snake An optional redundant Digital Snake cable can be run between the FOH Rack and each Stage Rack. This redundant Snake automatically takes over communication if the primary Snake fails.

FOH Rack

Mix Engine Cards Additional Mix Engine cards can be added to the FOH Rack (up to a maximum of 5 Mix Engine cards) for increased mixer and plug-in processing capacity.

FOH IOx Card An FOH Input/Output (IOx) card can be added to the FOH Rack, providing an additional 8 channels of analog I/O and 8 channels of AES/EBU Digital I/O for connecting out-board equipment.

Snake Card If a second Stage Rack is added, an additional Snake card is required in the FOH Rack. This additional Snake card supports the connection of a redundant Digital Snake cable to the second Stage Rack.

Record Options

FWx Record/Playback Option This FireWire-based option lets you record or play back up to 18 channels of audio directly from D-Show with a Pro Tools LE system.

HDx Record/Playback Option This option lets you record or play back up to 128 channels of audio directly from D-Show with a Pro Tools HD system.

Personal Q Monitoring Option

The Personal Q (PQ) monitoring system lets performers adjust their monitor mix being sent from D-Show, using a PQ Controller unit. D-Show can accommodate one PQ Rack and up to 8 PQ Controllers.

Redundant Power Supply Options

Factory-installable redundant power supply options are available separately for the control surface Main Unit and Sidecars.

User-installable redundant power supply options are available separately for the FOH Rack and the Stage Rack.

Ethernet Expansion Option

The Ethernet Expansion card allows remote control of all console functions using a standard wired or wireless Ethernet connection. This option lets you make EQ or mix adjustments from almost any location.

D-Show System Components

Included Components

The following components are included in a standard D-Show system:

Main Unit

- D-Show Main Unit
- AC power cord

Sidecar

- D-Show Sidecar unit
- AC power cord
- Console Link cable

FOH Rack

- FOH Rack unit with 2 Mix Engine cards
- AC power cord
- FOH Link cable for connection to Main Unit
- iLok USB Smart Key (for storing plug-in authorizations)

Stage Rack

- Stage Rack unit with 6 SRI (Stage Rack Input) cards and 1 SRO (Stage Rack Output) card.
- AC power cord

Software CDs

- System Restore CD
- Standalone Software Installer CD

Additional Required Components

The following components must be purchased separately:

- Digital Snake cable: this cable can be purchased directly from Digidesign or assembled by your preferred vendor.
- Video Display (15-inch or greater flat-panel TFT display recommended; 1024x768 minimum resolution)
- USB keyboard (Windows compatible)

Optional Components

The following components are optional, and must be purchased separately:

- USB flash disk (or other portable USB storage device for transfer of Show data; 512 MB or larger recommended)
- Near-Field Monitor Speakers (for FOH monitoring)
- Headphones with 1/4-inch jack (for FOH monitoring)
- 3-pin XLR Gooseneck Lamps (2 for Main Unit, 1 per Sidecar)
- Dynamic or condenser microphone and XLR mic cable (for Talkback)
- Footswitches (up to 2)
- MIDI cables (for connecting external MIDI devices to the MIDI ports on D-Show)
- BNC cables (for connecting word clock between the FOH rack and external digital devices)

Operational Requirements

Temperature and Ventilation

D-Show units should be operated away from heat sources and with adequate ventilation.

Storage

D-Show should be stored and transported at temperatures not lower than 0 degrees F (-18 degrees C) and not exceeding 140 degrees F (60 degrees C).

Operation

D-Show should be operated at temperatures not lower than 40 degrees F (4 degrees C) and not exceeding 115 degrees F (46 degrees C).

During operation, the back panel of each D-Show Main Unit and Sidecar should be exposed to ambient air. Do not block the ventilation holes on any D-Show unit.

Water and Moisture

D-Show units should be operated away from sources of direct moisture and should be kept clear of liquids that might spill into the units.

If condensation is present on the unit, leave the unit to dry in ambient air for at least one hour before powering the unit on.

Cleaning and Maintenance

If you need to clean the D-Show top surface, use a dry cloth. Do not apply any cleaning solutions, spray cleaners, or abrasives to the surface.

Connection Requirements

Power Connections

Each D-Show unit (Main Unit, Sidecar, FOH Rack, Stage Rack, and PQ Rack) requires its own power connection.

Make sure your power source is correctly rated for the number of units you are connecting. A surge protected power source (not included) is highly recommended.

Console Link Connections

Connections between the D-Show Main Unit and Sidecars or between individual Sidecars must be made with AES/EBU digital spec XLR cables, *not* with standard microphone cables.

FOH Link Connection

Connection between the D-Show Main Unit and the FOH Rack is made with the provided FOH cable. For replacement cables, contact Digidesign Customer Service.

 See Chapter 29, "FOH Rack Reference."

Digital Snake Connections

Connection between the FOH Rack and the Stage Rack is made with the provided Digital Snake cable. Replacement cables can be purchased directly from Digidesign or assembled by your preferred vendor. For Snake cable specifications and requirements, refer to the Digidesign Web site (www.digidesign.com).

Audio Connections

All D-Show external analog audio inputs and outputs are balanced XLR or balanced 1/4-inch connections. All D-Show external digital audio inputs and outputs are AES/EBU or S/PDIF connections.

 See Chapter 25, "Audio Specifications."

Compatibility Information

For a list of D-Show system requirements, cable requirements, and expansion options, refer to the Digidesign Web site (www.digidesign.com).

Chapter 2: Configuring and Connecting D-Show

The D-Show Main Unit and Sidecar can be placed in any order, and the input channel strip order configured accordingly. You can then bank input channels across the available input channel strips. Banking can be configured to affect all connected units globally, or configured for split (local) banking of faders and encoders.

Determining Control Surface Layout

Standard System Layout

On a standard D-Show system (one Main Unit and a single Sidecar on the left), D-Show input channel strips 1–16 appear by default on the Sidecar module, and channel strips 17–24 appear on the Main Unit.

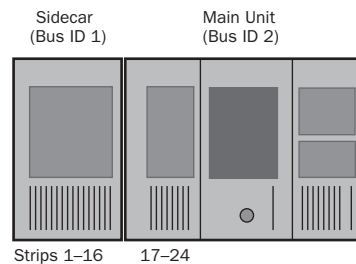

Input channel strip numbering on a standard system

You can place the Sidecar on the other side of the Main Unit, and customize the order of input channel strips by changing the Bus IDs of the units. See “Setting Control Surface Bus IDs” on page 8.

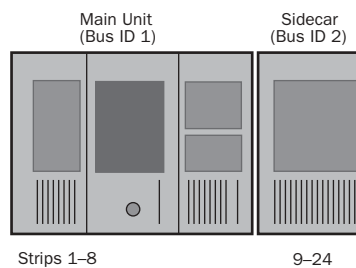

Alternative input channel strip numbering on a standard system

Expanded System Layout

On expanded D-Show systems, by default, input channel strips 1–16 appear on the leftmost Sidecar and progress to the right.

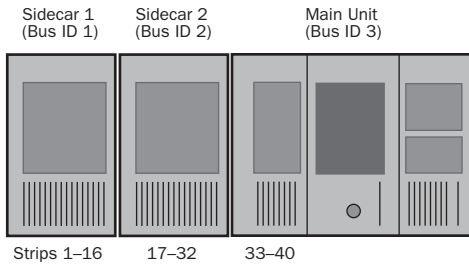

Input channel strip numbering on an expanded system

You can place Sidecars on either side of the Main Unit, and customize the order of input channel strips by changing the Bus IDs of the units. See “Setting Control Surface Bus IDs” on page 8.

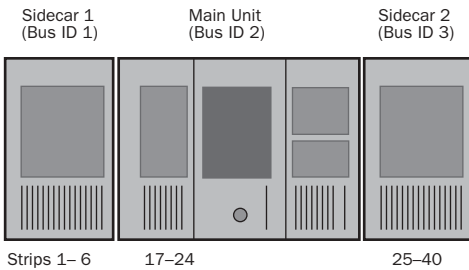

Alternative input channel numbering on an expanded system

Setting Control Surface Bus IDs

All units have a Bus ID selector in the upper left of the control surface top panel. Input channel strip numbering is determined by the Bus ID setting on each unit. Lower-numbered bus IDs correspond to lower-numbered input channels.

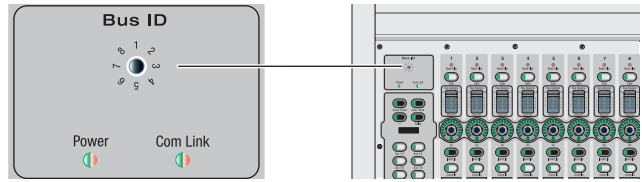

Bus ID selector

To set the Bus ID on a unit:

- With a small flat-head screwdriver, set the Bus ID as follows:
 - Set the ID to 1 to have input channel numbering start on that unit. Typically, this will be the leftmost unit in your system.
 - Set the ID to 2 on the unit you want to have the second set of input faders. For example, on a standard D-Show system (one Sidecar and one Main Unit) where the Sidecar is at the left of the Main Unit, the Main Unit should be set to Bus ID 2.
 - Set the ID of other units to match the layout of input channels.

Connecting D-Show Components

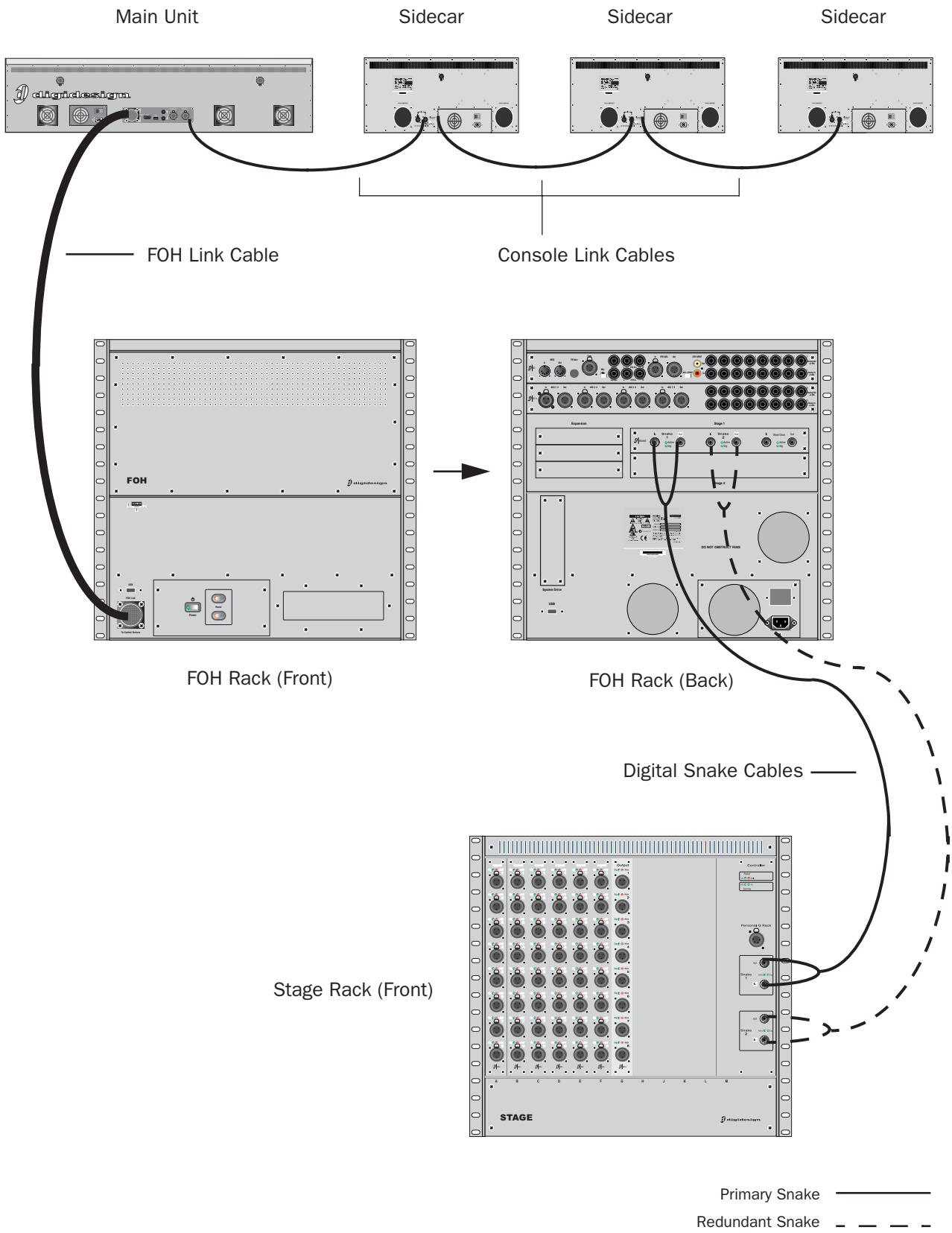

Figure 1. D-Show system component connections

Connecting the D-Show Main Unit and Sidecars

The D-Show Main Unit and Sidecars are connected with Console Link cables (one 15-foot cable is provided with each Sidecar), which are 110-ohm AES/EBU digital cables. The maximum length permissible for each Console Link cable is 25 feet (7.6 meters). Up to three Sidecars can be connected to the “Sidecar 1–3” port on the Main Unit.

To connect the Main Unit and Sidecars:

- 1 Connect the Console Link In port on the back panel of the nearest Sidecar to the “Sidecar 1–3” port on the back panel of the Main Unit.
- 2 On the successive Sidecars, connect the Console Link In port to the Console Link Out port on the previous Sidecar.

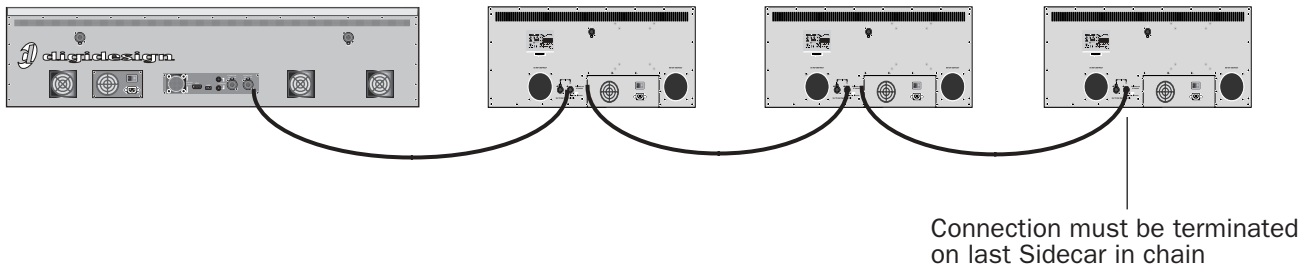

Figure 2. Console Link connections for Main Unit (left) and Sidecars (right)

- 3 On the last Sidecar only, terminate the Console Link connection with the Terminate switch.

Connecting the Main Unit to the FOH Rack

The D-Show Main Unit is connected to the FOH Rack with the provided FOH Link cable.

To connect the Main Unit and the FOH Rack:

- Connect one end of the FOH Link cable to the FOH Link port on the back panel of the Main Unit. Connect the other end of the FOH Link cable to the FOH Link port on the front panel FOH Rack. On each end, be sure to align the notch in the connector housing with the slot in the plug, and to rotate the collar until the connector is fully latched.

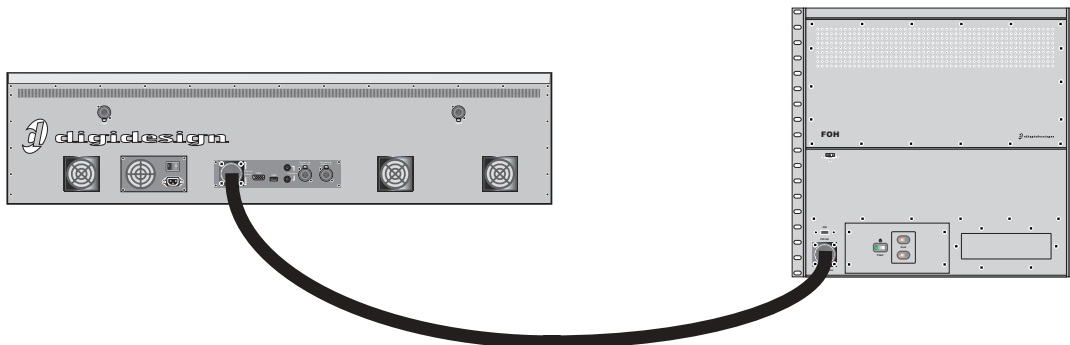

Figure 3. FOH Link connection between Main Unit (left) and FOH Rack (right)

Connecting the Stage Rack to the FOH Rack

The Stage Rack is connected to the FOH Rack with the Digital Snake cable (purchased separately).

To connect the Stage Rack to the FOH Rack:

- 1 On the Stage Rack, connect the Digital Snake cable lead with the white connector sleeve to the Snake 1 In port (this port label is outlined in white), and the Digital Snake cable lead with the red connector sleeve to the Snake 1 Out port.
- 2 On the FOH Rack, connect the Digital Snake cable lead with the white connector sleeve to the Snake 1 Out port (this port label is outlined in white), and the Digital Snake cable lead with the red connector sleeve to the Snake 1 In port.
- 3 If you are using a second, redundant Digital Snake, connect it to the Snake 2 ports on each unit in the same manner, matching the white connector sleeves to the ports whose labels are outlined in white.

⚠ The redundant Digital Snake must be the same length as the primary Digital Snake for each Stage Rack.

When the units are turned on, the Snake Signal LEDs (marked “Sig”) on the FOH Rack and the Stage Rack light solid to indicate the Snake connection. If the Snake Signal LEDs flash, a Snake connection has not been established.



If there are problems with the Snake connection, double check that all the BNC connectors are fully secured. If the problem persists, try reversing the red and white connectors on one end.

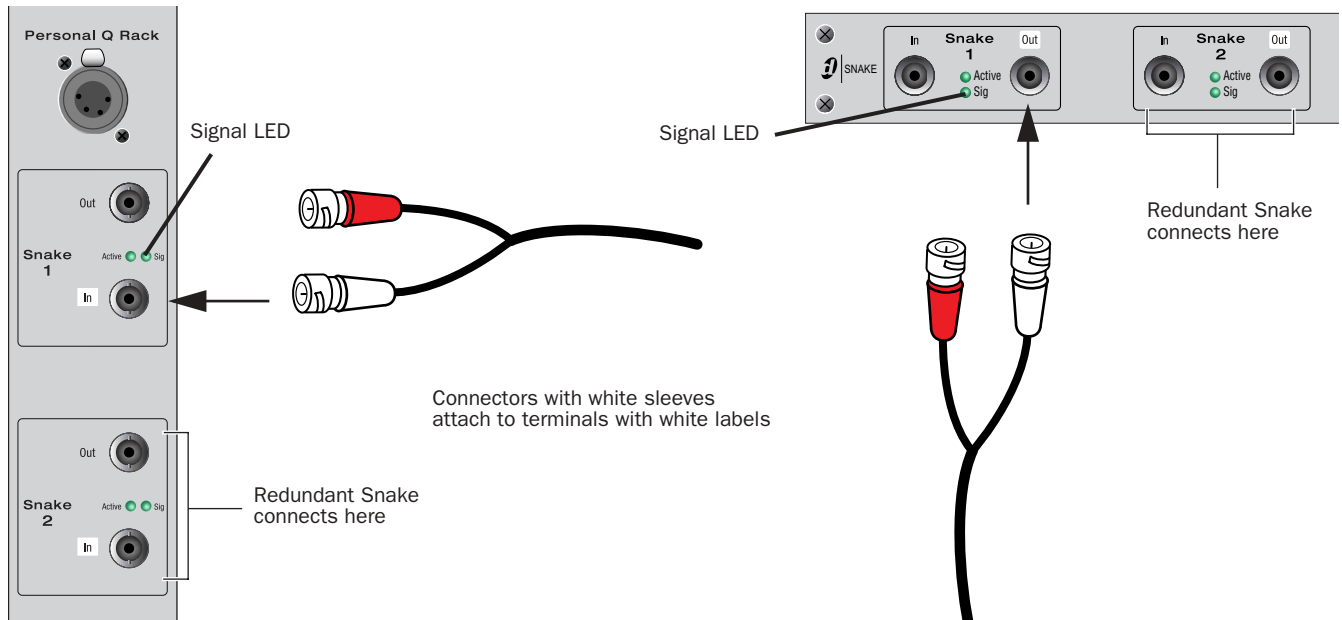

Figure 4. Detail of Digital Snake cable connection between Stage Rack (left) and FOH Rack (right)



If a second Stage Rack is used, an additional Snake Card must be installed in the FOH Rack. Follow the above instructions to connect the second Stage Rack to its corresponding Snake card.

Connecting a Second Stage Rack

Before connecting a second stage rack to a D-Show system, a second Snake card (purchased separately) must first be installed in the FOH Rack.

To connect a second Stage Rack:

- 1 Install a second Snake card in the FOH Rack. See the documentation that came with the Snake card.
- 2 Using a BNC cable (included with the additional Snake card), connect the Word Clock Out port on the first Snake card to the Word Clock In port on the second Snake card.

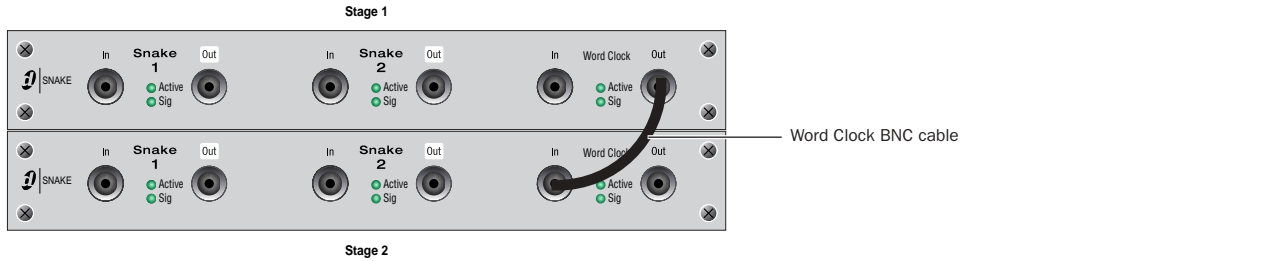

Word Clock connection between Snake cards

- 3 Connect the second Stage Rack to the FOH Rack with a Digital Snake cable. See “Connecting the Stage Rack to the FOH Rack” on page 11.

⚠ The redundant Digital Snake must be the same length as the primary Digital Snake for each Stage Rack.

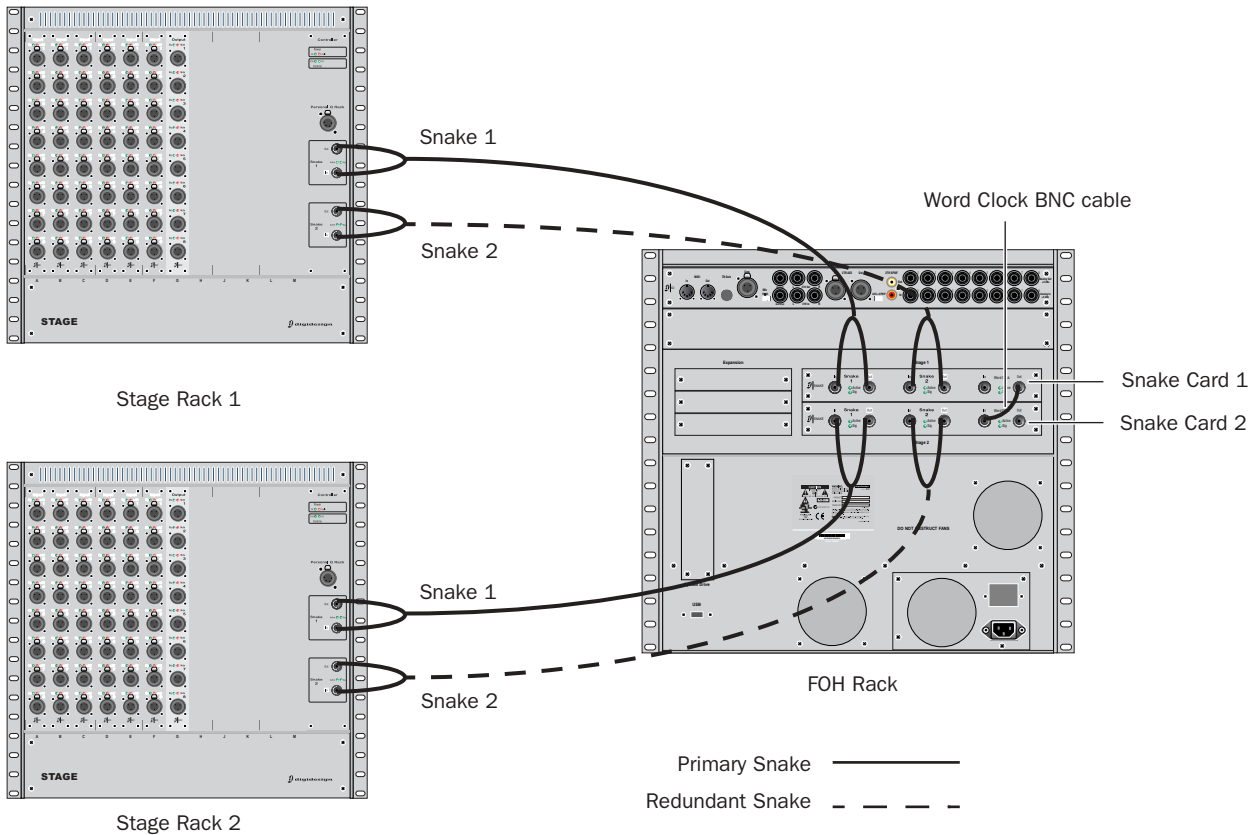

Figure 5. Digital Snake cable and word clock connections for fully redundant system with 2 Stage Racks

Power Connections

Each power supply in the Main Unit, the Sidecars, the FOH Rack, and the Stage Rack requires its own power connection. (If any unit includes an optional redundant power supply, it will require two dedicated power connections.) Each power supply is auto voltage-selecting (100V to 240V). A modular IEC power cable is provided for each power supply in the unit.

Audio and MIDI Connections

Stage Rack Connections

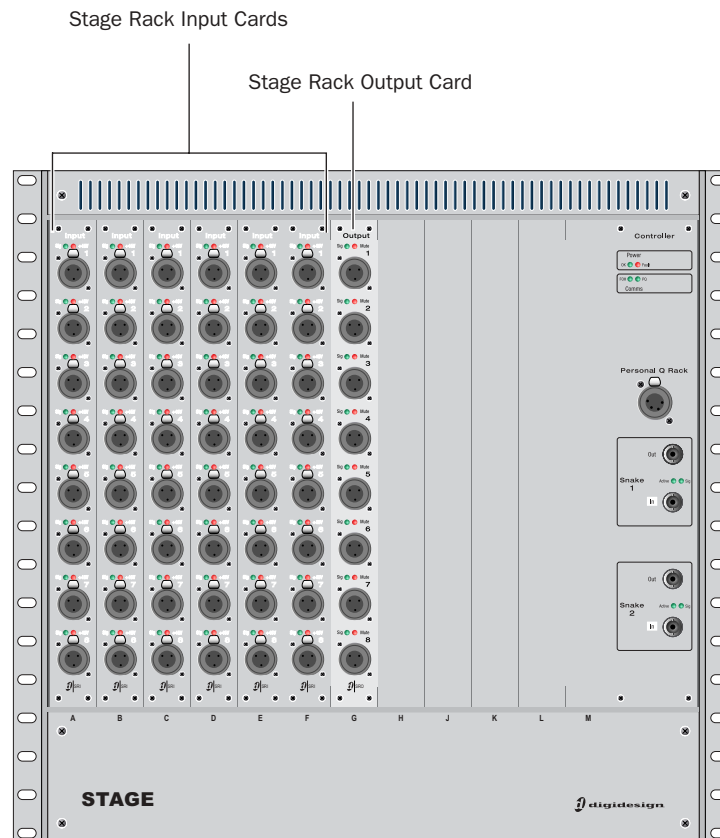

Figure 6. Audio connectors on Stage Rack

Analog Audio Inputs

(Balanced Female XLR Connectors)

◆ Connect analog mic-level or line-level input sources to any of the input connectors on any SRI Card.

Applying Phantom Power to Stage Rack Inputs

Each SRI Card input has available standard 48V phantom power.

⚠ *Before connecting or disconnecting a microphone on any Stage Rack Input, make sure phantom power is turned off for that input.*

To apply phantom power to a Stage Rack input source:

- 1 Target a channel in the ACS section of the control surface.
- 2 Press the +48V switch in the ACS Input section.

The corresponding channel's "+48V" LED on the Stage Rack Input Card lights to indicate phantom power is on.

Analog Audio Outputs

(Balanced Male XLR Connectors)

◆ Connect analog line-level output destinations (such as power amplifiers, crossovers, or speakers) to any of the output connectors on any SRO Card.

Digital Audio Inputs (Optional DSI Card)

AES

(XLR3-F Connectors)

- Connect digital AES sources to any of the input connectors on any DSI card. (See also “Digital Inputs and Sample Rate Conversion” on page 14.)

ADAT Optical

(TOSLink)

- Connect ADAT (optical) sources to the optical input connector on any DSI card.

Choosing the Digital Source (AES or ADAT)

To configure a digital input for AES or ADAT:

- 1 In the Patchbay, route a DSI input to a D-Show input channel.
- 2 Click the Inputs tab and navigate to the input channel being fed from the DSI input.
- 3 Click the ADAT button on-screen, in the channel Input controls section. When lit, ADAT input is active; when unlit, AES input is active.

The corresponding channel’s Source LED on the Stage Rack DSI Card lights to indicate AES or ADAT.

Digital Outputs (Optional DSO Card)

AES

(XLR3-M Connectors)

- Connect digital AES devices to any of the output connectors on any DSO card.

ADAT Optical

(TOSLink)

- Connect optical (ADAT) or other TOSLink devices to the optical output connector on any DSO card.

Digital Inputs and Sample Rate Conversion

The DSI card operates at the D-Show system sample rate of 48 kHz. The DSI card provides auto-detection and sample rate conversion on input, letting you connect a wide variety of digital sources without having to be concerned with synchronization and clock connections.

Sample Rate Conversion Latency

When sample rate conversion is enabled on DSI inputs, input signal paths will incur a small amount of latency. The following table illustrates the sample rate conversion processing delay at various sample rates.

Minimum Additional Latency due to Sample Rate Conversion

External Sample Rate	SRC Process Delay
32 kHz	1.50 ms
44.1 kHz	1.09 ms
48 kHz	1.00 ms
88.2 kHz	0.848 ms
96 kHz	0.833 ms

Sample rate conversion (SRC) can also be disabled. This provides the lowest possible input path latency, but requires that care be taken to synchronize the source and other devices accordingly (see “Synchronizing External Digital Source Devices” on page 15).

Even when SRC is disabled, connecting an unsynchronized device to a DSI input causes SRC to automatically be re-enabled. This lets audio continue passing without interruption.

To manually disable Sample Rate Conversion:

- 1 Click the Inputs tab and navigate to the input channel being fed from a DSI input.
- 2 Click the channel’s SRC OFF button until it turns off.

Auto-Detecting

The DSI card automatically detects whether an external device connected to a DSI input is synchronized to the D-Show system. Here, “synchronized” means the device is running at 48 kHz, and is clocked to D-Show (see “Synchronizing External Digital Source Devices” on page 15). In this case, no sample rate conversion is required on input.

If the external device is not synchronized, D-Show automatically engages sample rate conversion on those inputs *even if sample rate conversion was manually defeated*. The SRC LED flashes on the DSI card, and a message appears on-screen to indicate this condition.

 SRC status is not affected when an input channel is reset via right-click “Reset Strip” commands.

Sample rate conversion can be enabled or disabled manually for digital inputs, as follows:

- ◆ When using AES inputs on DSI cards, sample rate conversion can be enabled or disabled for each pair of inputs.
- ◆ When using ADAT (Optical) inputs on DSI cards, sample rate conversion can be enabled or disabled for all 8 channels. Enabling or disabling SRC on any ADAT channel enables or disables all other ADAT channels on that DSI card.

Switching input Source between AES and ADAT (Optical) ports retains the last sample rate conversion setting for that input type and channel (AES channel pairs only).

 Automatic detection and enabling of sample rate conversion is always in effect and will engage sample rate conversion whenever a mismatch is detected at a DSI input, even when sample rate conversion is manually defeated for that input.

Synchronizing External Digital Source Devices

When an external device is running at 48 kHz and clocked to D-Show, disabling sample rate conversion on those digital inputs provides the lowest possible input path latency.

Before sample rate conversion is defeated on any input connected to a digital source, that source device must be synchronized (clocked) at 48 kHz in one of the following ways:

Using Word Clock Out from the Stage Rack (DSI Card)

- ◆ Connect the Word Clock Out provided on the DSI card to the corresponding digital device. Set the external device to slave to the incoming word clock signal.

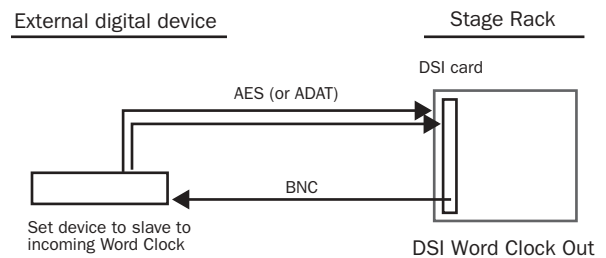

Using word clock from the DSI card to clock an external device

Using D-Show Digital Audio Outputs

- ◆ Connect any D-Show digital output to a digital input of the external device: Use digital outputs on the Stage Rack (if the system also includes a DSO card) or any digital output on the FOH Rack. Set the external device to slave to its digital input.

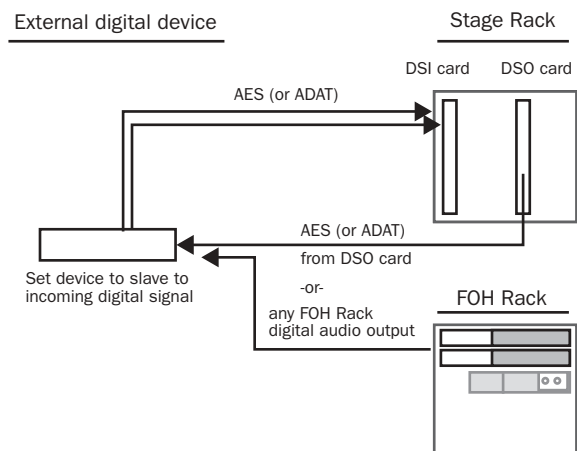

Using a D-Show digital output to provide clock to an external device

Using House Clock

◆ Connect a “house” or other external master clock signal to the Word Clock In on the FOH Rack. Distribute the same house clock to the external digital device, and set it to slave to the incoming house word clock signal.

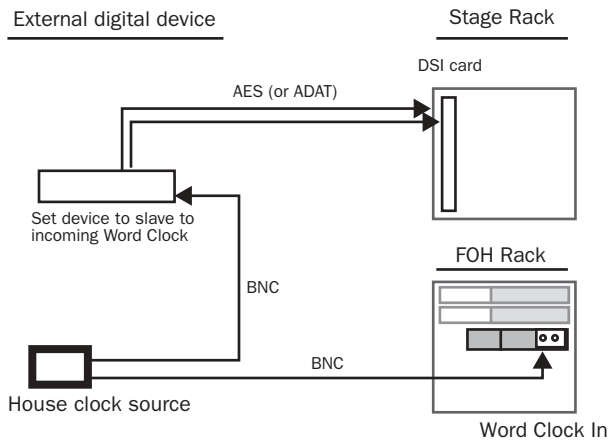

Using a distributed house (master) to clock D-Show and an external device

Using Word Clock Out from the FOH Rack

◆ Connect the Word Clock Out on the FOH Rack to the corresponding digital device. Set the external device to slave to the incoming word clock signal.

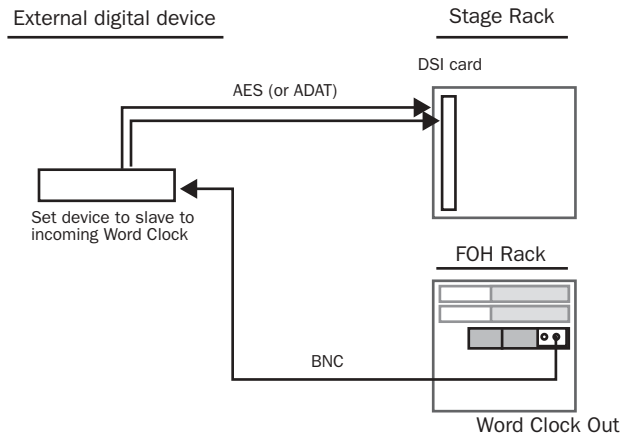

Using word clock from the FOH Rack to clock an external device

Digital Gain and HDx

In D-Show systems that include DSI digital input and the HDx Pro Tools Recording option, channel gain is maintained when switching input channels between available digital sources (from DSI to HDx, or vice versa).

As you adjust gain for channels that are sourced from one or the other digital source (DSI or HDx), any changes you make to channel gain are tracked by D-Show. Those changes can then be transferred and applied when that channel is switched from an HDx source to a DSI input using the Apply HDx Gain Changes command. Alternatively, you can choose to discard changes and revert to the stored gain value for that input source.

◆ If you choose to apply HDx gain levels when switching that channel to a Stage Rack DSI input, those levels will be transferred and applied directly to the new source. For example, if an HDx source has a gain setting +3dB, switching that source to a DSI input and choosing to apply gain changes will result in the DSI input being set identically to +3dB.

◆ If you choose to discard gain settings when switching that channel the DSI input will revert to its previous Stage Rack gain setting. The system remembers the type of each Stage input card upon entering HDx mode.

D-Show retains Stage Rack input gain settings as part of the HDx configuration for as long as the card is present in the system.

⚠ *When exiting HDx mode and returning to input from a Stage Rack (analog or digital card), if a given Stage input card type has changed (such as Analog to Digital or vice versa), any gain changes made to inputs on that card while in HDx mode are discarded even if you choose to apply gain changes.*

Analog Gain Reminder

Relative gain changes will still be applied when switching from HDx to an analog input source in order to preserve gain structure. For more information, see the *HDx TDM Record/Playback Option Guide*.

Digital and Analog Settings

D-Show automatically detects when a Stage Rack has been re-configured with the addition (or removal) of any analog or digital I/O card. When this occurs, D-Show will apply the last known settings (or default settings if no previous settings are available) for each card type.

FOH Rack Connections

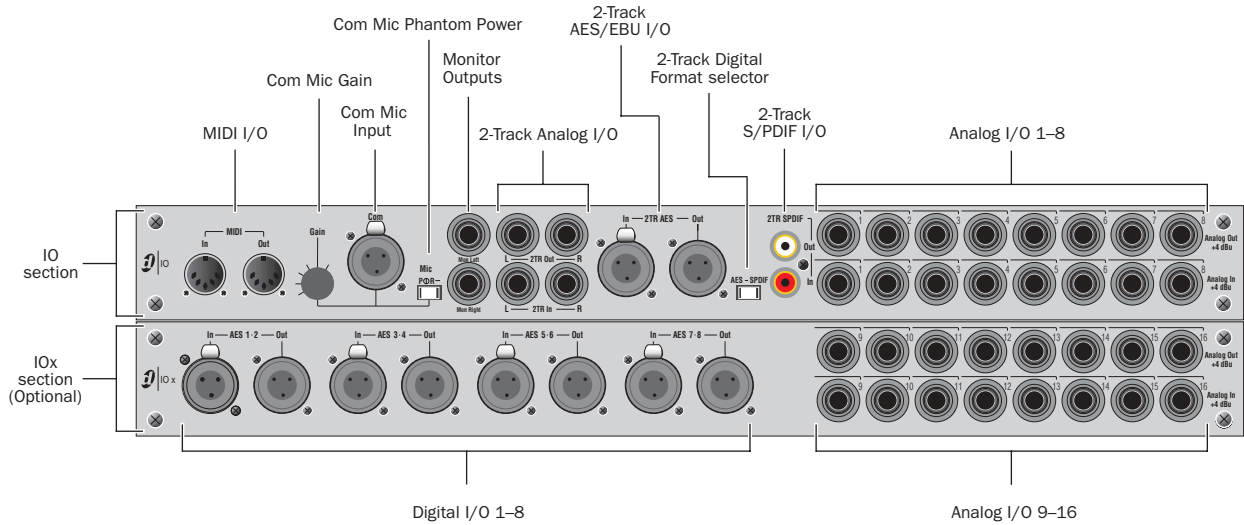

Figure 7. Audio connectors on FOH Rack, showing standard IO connectors (top) and optional IOx connectors (bottom)

Audio Inputs and Outputs

Analog Inputs and Outputs

(Balanced 1/4-inch TRS Connectors)

- ◆ Connect the analog inputs and outputs of external processors to any of these 8 analog output and input pairs. (16 inputs and output pairs are available if the IOx option is installed.)
- ◆ Connect any analog output destination (such as a recording device or broadcast feed) to any of the outputs in this section.
- ◆ Connect any analog sound sources (such as a CD player) to any of the inputs in this section.

Digital Inputs and Outputs - IOx Option only

(AES/EBU Connectors)

- ◆ Connect the two-channel digital inputs and outputs of external processors to any of the 4 AES/EBU digital output and input connectors in this section.
- ◆ These connectors support 24-bit, 48 kHz digital signals. Input signals with other sample rates are sample-rate converted to 48 kHz.

2-Track Inputs and Outputs

2-Track Analog Inputs and Outputs

(Balanced 1/4-inch TRS Connectors)

- ◆ Connect a 2-track analog playback source to the 2-Track analog inputs.
- ◆ Connect a 2-track analog recording device to the 2-Track analog outputs.

2-Track Digital Inputs and Outputs

(AES/EBU and S/PDIF Connectors)

- ◆ Switch the 2-Track digital I/O between AES/EBU and S/PDIF by moving the 2-Track Digital Format selector switch to the corresponding position. Only one of these digital formats may be active at a time.
- ◆ Connect a 2-channel digital playback source to the 2-Track AES/EBU or S/PDIF input.
- ◆ Connect a 2-channel digital recording device to the 2-Track AES/EBU or S/PDIF output.
- ◆ These connectors support 24-bit, 48 kHz digital signals. Input signals with other sample rates are sample-rate converted to 48 kHz.

Monitor Outputs

(Balanced 1/4-inch TRS Connectors)

- ◆ Connect a monitor amplifier or powered monitors to the Monitor Output connectors.
- ◆ The Monitor Outputs, and the Headphone Output on front of the Main Unit, are fed by the Solo/Monitor bus

Com Mic Input

Com Mic Connector

- ◆ Plug a dynamic or condenser microphone, or any compatible intercom system microphone into this connector.

Applying Phantom Power to the Com Mic

The Com Mic input has available 15V phantom power.

To apply phantom power to the Com Mic:

- Move the Mic Power switch to the right.

Com Mic Gain

- ◆ Turn the Com Mic knob to adjust overall Com Mic gain.

MIDI Input and Output

- ◆ Connect a compatible MIDI device to the MIDI In and MIDI Out ports. The D-Show Snapshot feature receives and sends MIDI commands, and generates and responds to MIDI Time Code.

Control Surface Connections

Talkback Mic

Talkback Mic Connector

- ◆ Plug a dynamic or condenser talkback microphone into this connector.

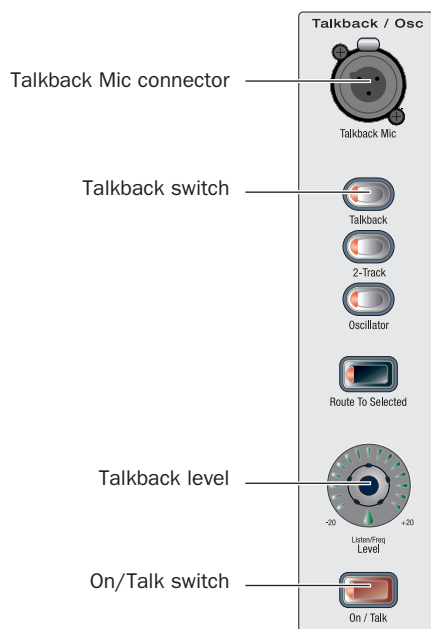

Talkback microphone connector and controls on the Main Unit

Talkback Level

- ◆ The talkback gain for this connector is fixed at 20 dB.
- ◆ Adjust talkback send level by pressing the Talkback switch in the Talkback/Osc section and turning the level knob.

Talkback Switch

- ◆ Activate talkback by pressing the On/Talk switch.

VGA Display

- ◆ Plug a compatible VGA display into this connector.

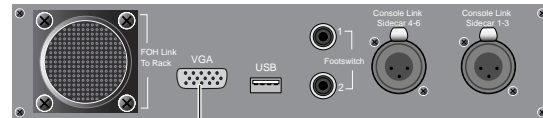

VGA Display connector

VGA display connector on back panel of the Main Unit

USB Keyboard

- ◆ Plug a compatible USB keyboard into any of the 3 available USB connectors on the Main Unit.

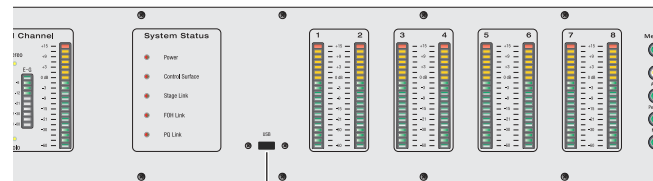

USB connector

USB connector on the meter bridge panel of the Main Unit

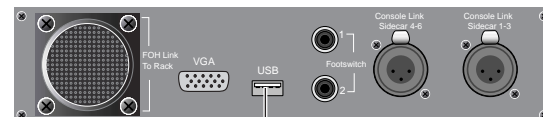

USB connector

USB connector on back panel of the Main Unit

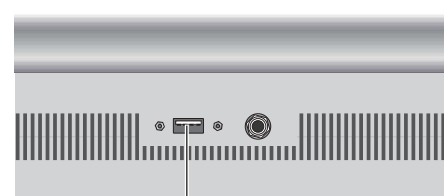

USB connector

USB connector on front panel of the Main Unit

Powering Up the System

⚠ *D-Show faders move when power is turned on. Before powering up the system, make sure all fader paths on the Main Unit and Sidecars are clear of obstructions.*

Power up the system in the following sequence:

- 1 Main Unit and Sidecars
- 2 Stage Rack
- 3 Front of House Rack
- 4 Any connected computers for recording/playback options
- 5 Audio monitoring system

💡 *On units with redundant power supplies, each power supply has a separate power switch.*

Powering Down the System

Power down the system in the following sequence:

- 1 Audio monitoring system
- 2 Any connected computers for recording/playback options
- 3 Front of House Rack
- 4 Stage Rack
- 5 Main Unit and Sidecars

Restarting the System

If at any time during setup or performance it becomes necessary to restart the system, you can restart the entire system or reset individual hardware devices.

📄 *For more information on restarting D-Show and resetting system hardware, see Chapter 27, “Troubleshooting.”*

Setting the System Clock

When you first work with a D-Show system, make sure the system clock time, date and time zone are set appropriately. The system clock setting can affect data synchronization with portable storage devices. See “Synchronizing Settings, Shows and Presets” on page 167.

⚠ *Changing the system clock while using a timed iLok license (for a plug-in with a demo period, or for a plug-in rental) may expire the plug-in authorization.*

Enabling a Second Stage Rack

To enable and confirm communication with the second Stage Rack:

- 1 Put D-Show in Config mode.
- 2 Go to the Options page and click the System Config tab.
- 3 Click Edit.
- 4 Select Enable Stage 2, and click Apply. D-Show restarts.



Enabling the second Stage Rack

- 5 Go to Options > Devices to view D-Show hardware status. The connection to the second Stage Rack should be displayed in the FOH Rack graphic.

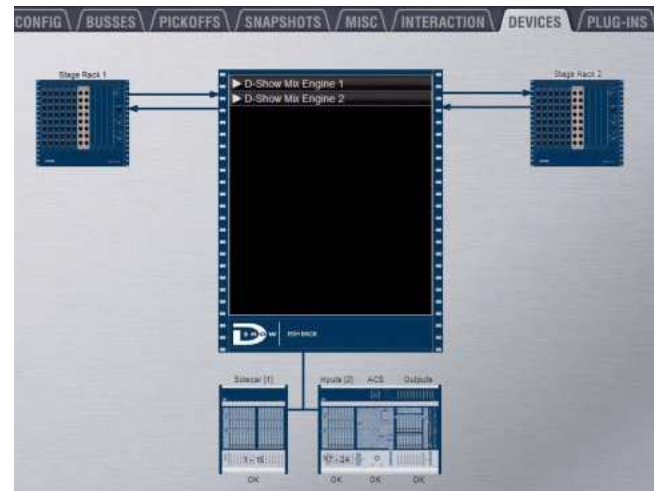

Detail of Devices page showing connection to second Stage Rack

💡 *The second Stage Rack must be enabled for the Devices tab to display the correct number of SRI (Stage Rack Input) and SRO (Stage Rack Output) cards in that unit.*

Part II: System Description

Chapter 3: D-Show Control Surface Overview

D-Show Main Unit and Sidecar Top Panels

The following figure identifies the main sections of the D-Show control surface:

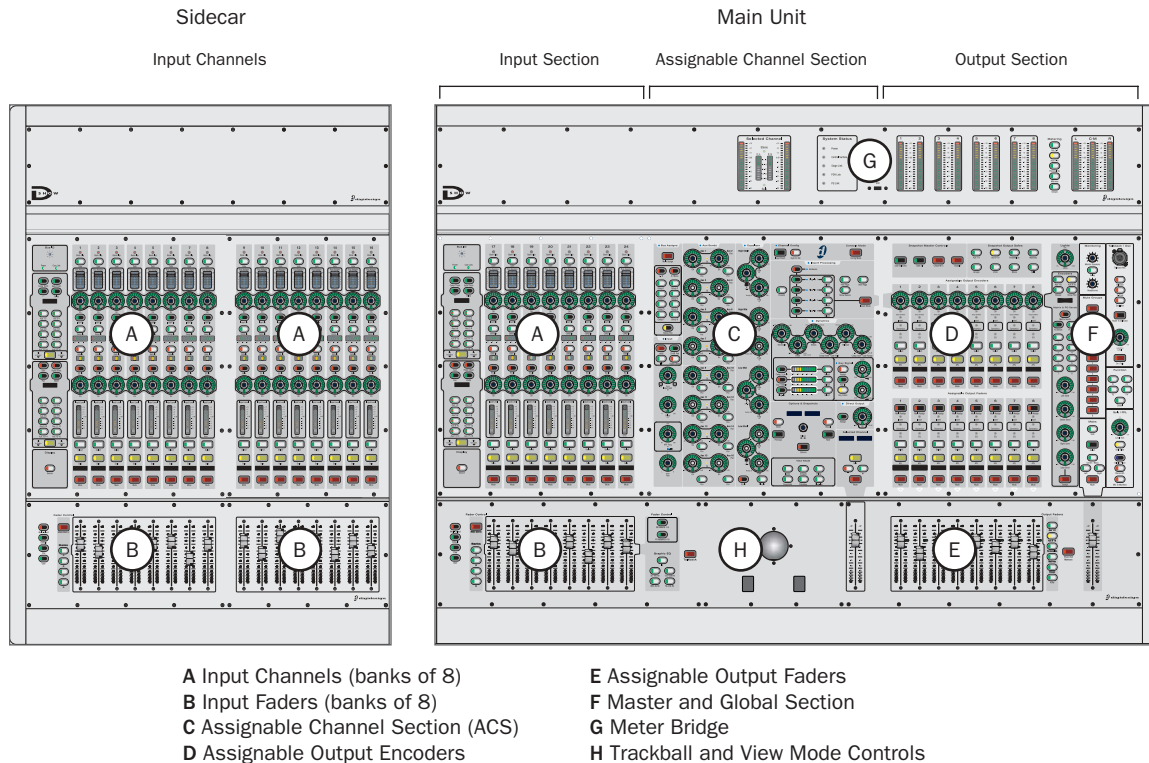

Figure 8. Control Surface main sections

The D-Show control surface consists of one Main Unit and one or more Sidecars. The D-Show Main Unit provides eight bankable input channel strips, the Assignable Channel Section (center section), eight Assignable Output Encoders, eight Assignable Output Faders, and one Mains Fader and Master Controls section.

Each D-Show Sidecar provides 16 additional bankable input channel strips. Sidecars can be attached to the left of the Main Unit (as shown above), attached to the right side, or kept free-standing (unattached) on either side.

Input Section

The Input Section provides Input Channels and FX Returns, with channel faders and two rows of assignable encoders.

Assignable Channel Section

The Assignable Channel Section provides expanded routing and processing controls for the currently targeted channel.

Output Section

The Output Section includes two sets of output controls that can be used to control two different sets of outputs at the same time:

- The Assignable Output Encoders adjust the assigned output or bus, or plug-in parameters (when in Insert mode), and are also where you set Matrix and PQ sends.
- The Assignable Output Faders adjust the assigned output, bus, or VCA.

Input Channels and Faders

Inputs include Input Channels and FX Returns. Each input strip provides level faders, solo, mute, and Select switches, two rotary encoders (with selectable functions), Bus Assign LEDs (routing indicators), as well as display LCDs and status LEDs.

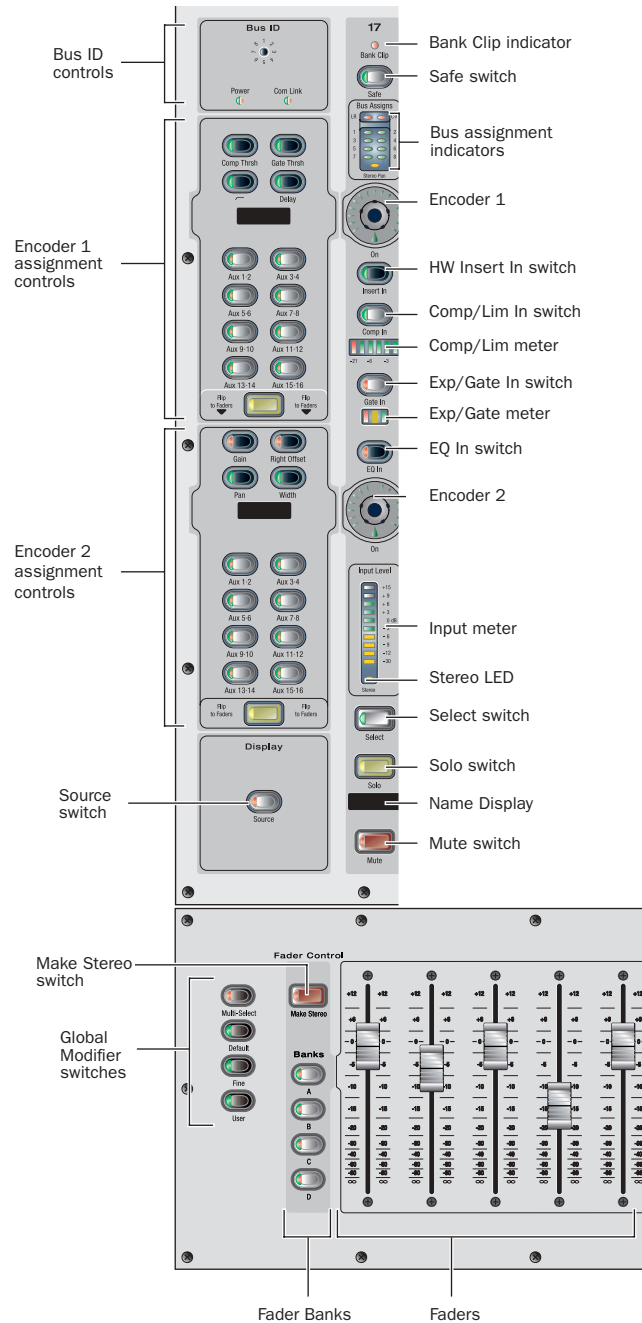

Input strip and fader controls

Bank Clip Indicator

The Bank Clip Indicator lights to indicate a meter clip on an Input Channel or FX Return at the corresponding position in an alternate bank of channels. This indicator obeys the same clipping threshold display rules as the Input Channel meters (as set in the Options > Interaction page). It gives you an indication of extreme signal level in a currently hidden (“off-bank”) layer.

Safe

Automation Safe or Solo Safe

The Safe switch controls either an input strip’s Automation safe status or Solo safe status, depending on the current Input Safe Switch setting. See “Input Safe Switches” on page 54.

Pressing a channel Safe switch toggles the current state of that channel as follows:

Auto Safe Mode If the Safe LED is lit, the channel will not respond to Snapshot-driven changes. If the LED is off, that channel will respond to any applicable changes driven by Snapshots (subject to the current Recall Safe settings, if Recall Safe is enabled).

Solo Safe Mode If the Safe LED is flashing, the channel will not respond to solo commands (it will not be muted if another channel’s solo button is pressed). If the LED is off, that channel will be silenced when soloing another channel.

Bus Assignment Indicators

These green LEDs indicate Group bus assignments, and can also show VCA or Mute Group membership for each channel. By default, Group bus assignment is displayed.

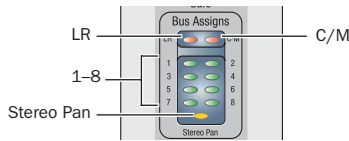

Group indicator LEDs on an Input Channel

Group Bus Assignment

- ◆ If the LR LED is lit, the input channel feeds the Left and Right Main busses in either L-R or L-C-R panning mode (regardless of the Stereo Pan LED status).
- ◆ If the C/M LED is lit, the input channel feeds the C (center) bus from the pan in L-C-R mode, or the M (mono) bus before the pan. Stereo channels are summed to the mono bus.
- ◆ If a bus LED (1-8) is lit, the channel is feeding the corresponding Group(s). If an LED is off, the channel is not feeding that Group. The Bus Indicators can also show VCA and Mute Group membership.

 Use the Bus Assign switches in the ACS to route and assign channels to busses (see “Assignable Channel Section (ACS)” on page 28).

VCA Membership

- ◆ When the VCA Show Members switch is pressed, Group indicator LEDs flash to indicate VCA assignment. A flashing LED indicates that the channel is assigned to the corresponding VCA (1-8).

Mute Groups

- ◆ When the Mute Groups Show Members switch is pressed, the Group indicators flash to indicate Mute Group assignments. A flashing LED indicates that the channel is assigned to the corresponding Mute Group (1-8).

Input Encoders and Assignment Controls

Input Channels contain two separate banks of rotary encoders that can be assigned to control a variety of channel functions such as input gain, HPF corner frequency, pan/balance/width, and specific parameters of built-in Dynamics processes.

The Encoder Assignment switches, located to the left of each row of encoders, determine the function of the encoders on Input Channels. The LCD within each set of encoder controls displays the current function.

Rotary and Switch Functionality

D-Show rotary encoders are dual-function controls that provide rotary and switch functions. In addition to adjusting parameters by turning the encoder, you can toggle parameters (such as taking the high-pass filter in or out of circuit) by pressing the encoder knob.

Encoder LEDs

Two types of LEDs surround each encoder:

- ◆ The LED ring around the encoder displays the relative position of its currently assigned parameter.
- ◆ Below each encoder is an indicator LED, which indicates parameter status (in/out) and various conditions related to the current encoder function.

Encoder 1 Assignment Switches and Functions

The Encoder 1 Assignment switches assign the following functions to Encoder 1 on each input channel strip:

Comp/Lim Thrsh Assigns the encoders to control the Threshold for the built-in Compressor/Limiter. Pressing the encoder toggles the effect in and out of circuit.

Exp/Gate Thrsh Assigns the encoders to control the Threshold for the built-in Expander/Gate. Pressing the encoder toggles the effect in and out of circuit.

HPF Assigns the encoders to control the HPF corner frequency. Pressing the encoder takes the built-in HPF in and out of circuit. If the LED is lit, the filter is in circuit.

Delay Assigns the encoders to control the amount of delay in the channel. Pressing the encoder takes the Delay in and out of circuit. If the LED is lit, the delay is in circuit.

AUX 1•2 TO AUX 15•16 Let you select one of two Aux sends in odd/even pairs.

- ◆ With mono sends, the first press of the switch selects the odd numbered send (1, 3, 5, or 7) and the second press selects the even numbered send (2, 4, 6, or 8). The switch lights green for the odd-numbered selection, or yellow for the even-numbered selection.

- ◆ With stereo-linked sends, the first press of the switch controls level for the bus pair, and the second press controls pan for the bus pair. The switch lights green for level control, or yellow for pan control.

Pressing the Encoder 1 then toggles the send on or off. When the send level is shown on the LED ring and the send is off, at most a single LED in the ring lights. When the send is on, all LEDs light in a clockwise sequence from the lower left to the send level.

When D-Show is in Variable Groups mode, the switches for Aux 1–2 through Aux 7–8 can be used to select Variable Group sends, and use the Encoder 1 to control the Variable Group send on/off, level, and pan parameters.

Aux Pan With stereo-linked Auxes or Variable Groups, the first press of this switch selects the level control for the Aux or Variable Group bus pair (green LED) and the second press selects the pan/balance control for the pair (yellow LED). When the Aux or Variable Group pair is following Main pan, the second press is not available. For more information, see “Aux Bus and Variable Group Bus Signal Flow Options” on page 88.

Pan mode is indicated by the single-dot LED ring light pattern. Stereo-linked busses use a yellow color backlight in their name displays in the Outputs section to indicate stereo linking.

FLIP When enabled, the current encoder parameter is mapped to the channel faders. It can still be controlled from the encoder row, so the channel fader mirrors the setting. When Flip is engaged, all channel name display backlights turn yellow, the same color as the flip switch.

 *It is not possible to flip controls for both sets of encoders at once, and the last-pushed Flip switch overrides any previous Flip state.*

Display The 6-character display shows information about the currently selected function.

Table 4. Encoder 1 Displays

Switch	Display
Comp Thr	COMP
Gate Thr	GATE
	HPF
Delay	DELAY
Aux	AUX (number). Displays abbreviated name if Aux output is changed from default name
Aux (stereo)	APAN (number) Odd-numbered Auxes display pan information when Auxes are stereo-linked
Flip	Retains current selection

Encoder 2 Assignment Switches and Functions

The Encoder 2 Assignment switches assign the following functions to Encoder 2 on each input channel strip:

Pan/Bal Assigns the encoders to control channel Pan if the channel is mono, or stereo channel balance if a stereo. The indicator LED lights when the pan is at center.

Width (Stereo Channels Only) Assigns the encoders to control the ganged pan positions of Left channel and Right channel at the same time, but in opposite directions. Turning clockwise moves the pans towards full stereo, turning counter-clockwise moves the pans toward reverse-stereo. Since width is only applicable to stereo strips, this control is disabled when the associated input strip is mono.

Gain Assigns the encoders to control input gain according to the range available for this input. Pressing that holding the encoder initiates Gain Guess, in which D-Show automatically sets a nominal input gain level based on the incoming signal.

Right Offset (Stereo Channels Only) Assigns the encoders to control the gain offset of the right channel relative to the left. The offset ranges from –20 dB to +20 dB at the maximum but this range can be restricted depending on the current Gain setting.

AUX 1•2 to AUX 15•16 Same as in Encoder 1 Assignment panel (see “Encoder 1 Assignment Switches and Functions” on page 25).

Flip Same as Encoder 1 Assignment panel (see “Encoder 1 Assignment Switches and Functions” on page 25).

 *It is not possible to flip controls for both sets of encoders at once, and the last-pushed Flip switch overrides any previous Flip state.*

Display The 6-character display shows information about the currently selected function.

Table 5. Encoder 2 Display

Switch	Display
Pan/Bal	PANBAL
Width	WIDTH
Gain	INP GN
Gain R	RGHTGN
Aux	AUX (number). Displays abbreviated name if Aux output is changed from default name
Flip	Retains current selection
Aux (stereo)	APAN (number) Odd-numbered Auxes display pan information when Auxes are stereo-linked

Insert In Switch

This switch toggles the hardware insert in and out of circuit (if assigned). If the switch is lit, the process is in circuit. Insert sends and returns are assigned in the Patchbay. On Inputs, the insert send is always sending. This switch does not affect inserted plug-ins. Plug-ins can be bypassed individually in the Assignable Channel Section.

Comp In Switch

This switch toggles the built-in Compressor/Limiter in and out of circuit. If the switch is lit, the process is in circuit.

Gate In Switch

This switch toggles the built-in Expander/Gate in and out of circuit. If the switch is lit, the process is in circuit.

EQ In Switch

This switch toggles the built-in EQ in and out of circuit. If the switch is lit, the process is in circuit.

Input Strip Meters

There are three meters within this section in the channel strip. D-Show Input (and Output) meters display nominal level.

Input Meter

The 10-segment input meter displays the level of the incoming input signal. A segment lights when the level of the incoming signal reaches or exceeds the segment's corresponding label.

The entire meter lights red if the signal is clipping at any of the strip's multiple clip points. Normally, segments up to and including the segment labeled 0 dB display as green and the segments above 0 dB display as yellow.

 *Because the lowest meter level is -30 dB, any input signal that is less than this value will not register on the input strip meter. The Selected Channel meter on the meter bridge and the on-screen meters register activity below -30 dB.*

Stereo LED Below the input meter is a Stereo LED. This LED lights if the associated input strip is stereo. The LED flashes on/off anytime the strip is stereo and the difference in instantaneous peak level between left and right sides is 12 dB or more.

Comp/Lim Meter

The Compressor/Limiter meter has 6 LEDs to show the amount of gain reduction being applied to the signal by the built-in Compressor/Limiter. For more information, see Chapter 16, "Dynamics."

Expander/Gate Meter

The Expander/Gate meter has 3 LEDs to show the open/closed state of the built-in Gate, or the amount of gain reduction applied by the Expander. For more information, see Chapter 16, "Dynamics."

Select Switch

The Select switch on each channel is used to target the channel in the Assignable Channel Section, and to include the channel in Multi-Select and Multi-Assign functions. A lit Select switch indicates the channel is selected. The name of the currently selected channel is displayed in red in the Channel Name display and in the ACS Selected Channel display. When multiple channels are selected, the red Channel Name display indicates which channel is currently the ACS target.

Solo Switch

The Solo switch toggles the solo state of that channel. When enabled, the Solo switch LED is lit. When the channel is in Solo Safe mode, the Solo switch LED flashes. Channel Solo latches on a momentary press, and automatically releases if held for 2 seconds or more and released.

Source Switch

The Source switch changes the Channel Name display to show the source input which is feeding each channel.

Name Display

This 6-character display shows the name of the channel, or Source if the Source switch is pressed. The name display for the currently selected channel is lit red. The channel name display can show other types of information according to the state of the Source switch or the current action.

Names This is the default display which shows the abbreviated channel names on all displays.

Values When a control is moved (or a fader is touched), the Channel Name display changes to Values display mode, where it shows each fader level or encoder function level as it is adjusted. You can turn off Values display switching so that the Name display does not show fader values. See "LCD Displays" on page 55.

Source When this switch is pressed, the Name displays show the source input feeding each channel. Sources are abbreviated to indicate hardware input source and channel number. For example, if "S1A1" appears in a Channel Name display when Source is enabled, it indicates that the channel source is Stage Rack 1, Card A, Input 1.

Mute Switch

The Mute switch mutes the channel at the (pre-fader) mute point. Channel pre-fader pickoff is post-mute.

Faders

Each channel fader is a 100mm motorized, touch-sensitive fader.

The Options > Interaction screen lets you enable touch-sensitive channel selection. When enabled, touching a channel fader automatically selects that channel and makes it the ACS target.

 *The faders on D-Show can be moved even when they do not sense a touch. This allows use of the faders while wearing gloves. It also lets you “throw” a fader and have it stay where it lands, and not snap back to the point it was last touched.*

Fader Banking Controls

Bank A–D The Bank A–D switches bank the Input strips, and let you link/unlink banking from each unit. By default, Bank width varies based on the number of Sidecars present. For example, on a system with one Sidecar, Bank A is channels 1–24, Bank B is channels 25–48, and so on. On systems with two Sidecars, Bank A is channels 1–40, Bank B is channels 41–80, and so on. The Options > Interaction screen lets you configure fader banking as global (all units in tandem) or split (local banking of faders, and encoders, on the main Unit and on each Sidecar). For more information, see “Main and Sidecar Split Banking” on page 39.

FX Returns The FX Return switches bank FX Return channels to the Input faders of the Main Unit.

Graphic EQ The Graphic EQ switches bank bands of graphic EQ to the faders. Graphic EQs can be used on D-Show outputs only. For more information, see Chapter 17, “EQ.”

Global Modifier Switches

To the left of the Bank A–D switches are the global modifier switches. See “Global Modifier Switches” on page 34.

Multi-Select Lets you select multiple input channels.

Default Lets you reset a parameter, section, or channel to default values.

Fine Lets you adjust rotary encoders with greater resolution for finer control.

User This switch is currently not implemented.

Make Stereo Switch

The Make Stereo switch lets you combine two mono channels into one stereo channel, or split a stereo channel into two mono channels. See “Combining Input Channels (Make Stereo)” on page 60.

Assignable Channel Section (ACS)

The Assignable Channel Section provides dedicated routing, EQ, Dynamics, and insert controls for the currently selected channel.

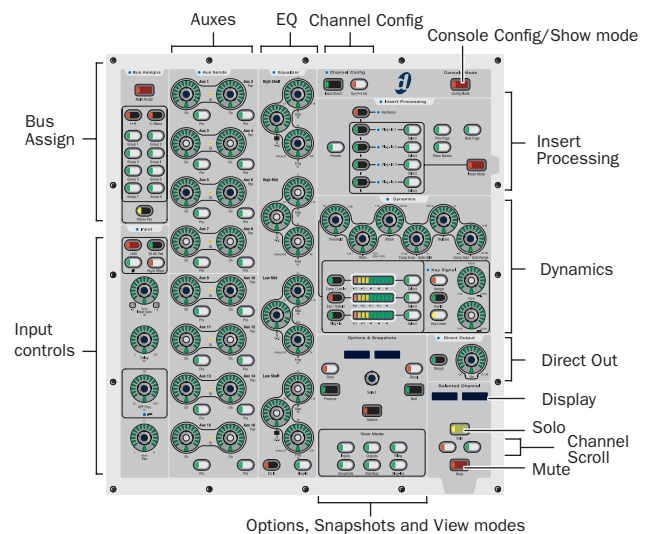

ACS main sections and controls

Input Controls

This section provides direct access to channel gain, HPF, delay, phantom power, and polarity (phase) for the currently selected channel.

Bus Assign

The Bus Assign switches are the primary routing controls for the currently selected channel, letting you bus it directly to the Main (L–R) bus or to any other mono or stereo group.

When D-Show is in Variable Groups mode, the Stereo Pan Switch in this section is used to display Variable Group parameters on the ACS Aux Sends controls.

Aux Sends

The Aux Sends section provides in/out and level control to route the currently selected channel to any available mono or stereo-linked Aux bus.

When D-Show is in Variable Groups mode, the controls for Aux 1–2 through Aux 7–8 can be used to route the currently selected channels to any available mono or stereo-linked Variable Group bus.

EQ

The EQ section provides dedicated controls for all built-in and compatible plug-in EQ parameters including band in/out, frequency, Q, and mode.

 See Chapter 17, “EQ.”

Channel Config

The Channel Config controls include the Input Direct and Dyn Pre EQ switches.

Input Direct Bypasses the built-in Dynamics and EQ processing, and all inserts on the currently targeted Input Channel or FX Return. The switch flashes to indicate Input Direct is active.

Dyn Pre EQ Enable Dyn Pre EQ to route audio on the currently targeted Input Channel to built-in Dynamics first, then to built-in EQ. The switch lights to indicate Dynamics precedes EQ in the signal path.

Config/Show Mode

This switch toggles D-Show between these two operational modes.

 See Chapter 6, “Options.”

Insert Processing

The Insert Processing section provides controls to bypass and adjust plug-ins on the currently selected channel, as well as to bypass hardware inserts.

Dynamics

The Dynamics section provides dedicated controls for built-in and plug-in dynamics processors, including a comprehensive set of Compressor/Limiter and Expander/Gate controls.

 See Chapter 16, “Dynamics.”

Direct Output

The Direct Output section provides level and in/out control for the channel direct output.

Solo and Mute

These switches provide channel Solo and Mute for the currently selected channel.

Channel Scroll

The Channel Scroll switches let you target other channels to bring them to the ACS (as an alternative to pressing channel Select switches). Press “+” to select the next channel. Press “-” to select the previous channel.

Options and Snapshots

The Options and Snapshots section, directly above the View Mode switches, provides access to the snapshots list.

Selected Channel Fader

The Selected Channel Fader is a 100mm, touch-sensitive fader that duplicates the fader for the selected channel.

Assignable Output Encoders

This section includes the eight Assignable Output Encoders and their corresponding function switches.

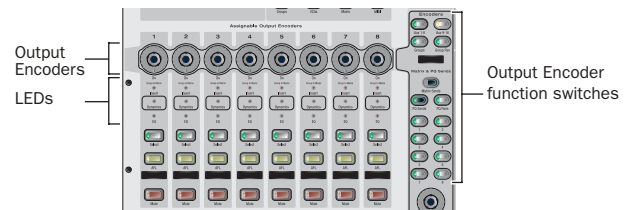

Assignable Output Encoder section

The switches to the right of the output encoders determine the function of the Output section Encoder row and its controls. When a function is selected, the Output Encoder section provides level control (using the encoders), solo, mute, and select switches for that output type.

Output Encoder Function Switches

Aux 1–8 Assigns the Output Encoder section to Auxes 1–8.

Aux 9–16 Assigns the Output Encoders section to Auxes 9–16.

Groups Assigns the Output Encoders section to Groups.

When D-Show is in Variable Groups mode, this switch assigns the Output Encoders section to control Variable Groups.

Group Pan Assigns the Output Encoders to (stereo) Group pan.

Display Shows the currently assigned function of the Output Encoder section.

Matrix and PQ Sends

The switches in the Matrix and PQ Sends section assign the Output Encoders to the following functions:

Matrix Sends Assigns the Output Encoders to control matrix input source levels and enables.

PQ Sends Assigns the Output Encoders to control PQ input source levels and enables.

PQ Pan Assigns the Output Encoders to control PQ input source panning.

Matrix/PQ 1–8 Assign the Output Encoders to show Matrix or PQ send levels and enable status, or Pan for selected Matrix or PQ send.

Left, Center, Right, and User Send Control the level of the Left, Center, Right, or User bus to the currently selected Matrix or PQ bus. Rotating the encoder adjusts the level; pushing the encoder toggles the send in/out.

Solo, Mute, and Select Provide solo, mute, and select for Auxes or Groups assigned to the Output Encoders.

Output Encoder and Output Fader Status LEDs

These multi-color LEDs indicate EQ, dynamics, plug-in, and insert status for the corresponding Assignable Output Encoders and Assignable Output Faders.

EQ LED

EQ LED color indications

Color	Meaning
Green	Output has a Graphic EQ and/or one or more EQ plug-ins assigned and in-circuit
Yellow	Output has a Graphic EQ and/or one or more EQ plug-ins, but none are in-circuit
Off	No Graphic EQ or EQ plug-ins are assigned on the current output

DYN LED

Dyn LED color indications

Color	Meaning
Green	Output has a Dynamics plug-in assigned and in-circuit
Yellow	Output has one or more Dynamics plug-ins, but none are in-circuit
Off	No Dynamics plug-ins are assigned on the current output

INSERT LED

Insert LED color indications

Color	Meaning
Green	Output has at least one of the following currently in-circuit: a hardware insert, and/or at least one non-EQ and non-Dynamics plug-in
Yellow	Output has at least one of the following but none are in-circuit: a hardware insert, or a non-EQ and non-Dynamics plug-in
Off	Output has no hardware insert or plug-in

Assignable Output Faders

The Assignable Output Faders control the currently selected Output type (Auxes, Groups, Matrix, PQ, or VCAs), chosen using the Output Faders switches.

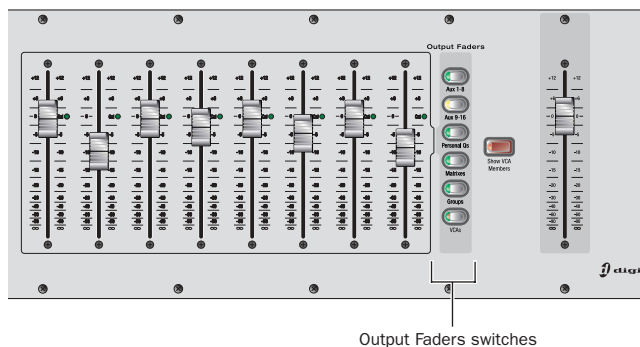

Output faders

Aux 1–8 Assigns the Output Faders to control Aux 1–8 levels.

Aux 9–16 Assigns the Output Faders to control Aux 9–16 levels.

Personal Q's Assigns the Output Faders to control PQ mixer output levels.

Matrixes Assigns the Output Faders to control Matrix mixer output levels.

Groups Assigns the Output Faders to control Group levels.

When D-Show is in Variable Groups mode, this switch assigns the Output Faders to control Variable Groups.

VCAs Assigns the Output Faders to control VCAs.

Master and Global Controls

The Master and Global section is located at the far right of the Main Unit. It includes the Monitoring, Mute Groups, Mains, Talkback/Com, Function, and Solo/PFL sections and controls.

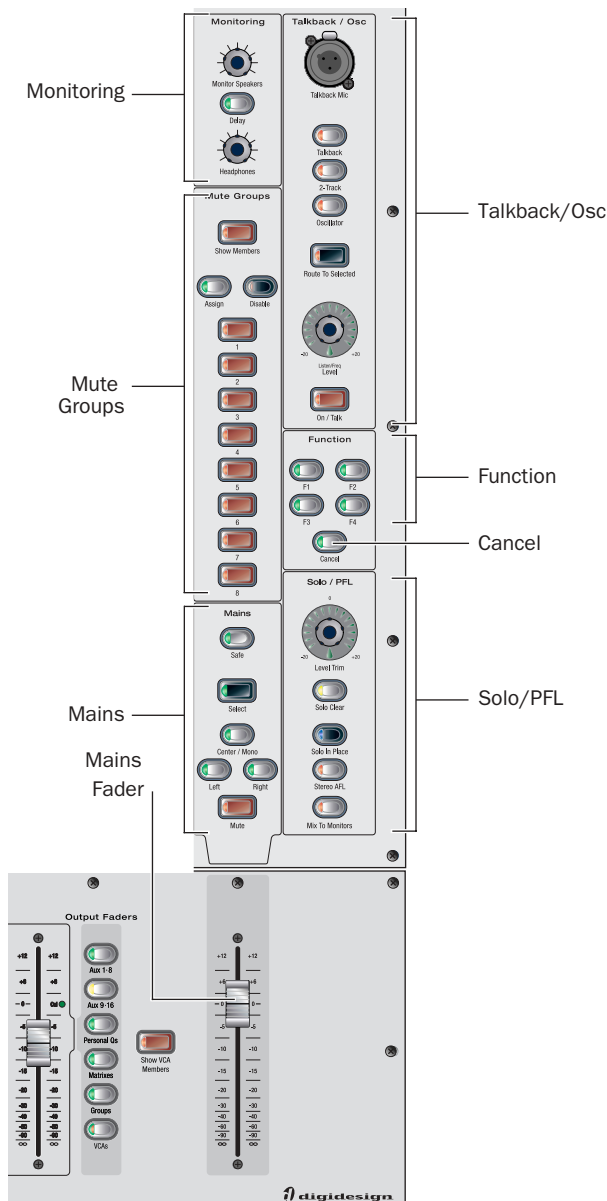

Master and Global controls

Monitoring

This section provides level and delay controls for near-field monitors and headphones. Separate level controls are provided for the monitor and headphone outputs. The Delay switch lets you set an amount of delay to be applied to both, to time-align their output at the front of house position.

Mute Groups

Mute Groups let you quickly mute multiple channels at the same time. You can create and recall up to eight Mute Groups comprising one or more channels.

See Chapter 15, “Muting and Mute Groups.”

Mains Controls and Fader

This fader and its function switches let you control the Main (or “house”) bus levels (L–R+M, or L–C–R).

The function switches directly above the Mains Fader let you select which Main output bus the Main Fader controls. This lets you assign the Mains Fader to all the Main busses (L–R+M, or L–C–R) simultaneously, or to individual Main busses to trim and balance Main bus output levels.

On-screen, three discrete faders are provided for L, R, and C/M. By default, the on-screen L and R faders are linked for stereo level adjustment; drag the C/M fader to adjust its level. On the control surface, all three Mains channels are enabled at the Mains Fader (L, R, and C/M).

Talkback/Osc

The controls in this section provide comprehensive and flexible communication control, including a top-mounted Talkback input (XLR), Assign switches, and level control.

Function Switches

This section provides four Main Function switches (F1, F2, F3, and F4) and the Cancel switch.

F1 Toggles snapshot Preview mode on or off.

F2 When D-Show is in Variable Groups mode, the F2 switch is used to toggle display of Variable Group controls in the Input Encoder rows and the ACS.

F3 Copies the currently targeted channel settings to the clipboard.

F4 Pastes the contents of the clipboard to the selected channel(s).

Cancel Cancels the current operation, such as Multi-Select or Multi-Assign modes.

Solo/PFL

This section provides control over the primary Solo features, including Solo Level and mode selection. Numerous options are provided to customize D-Show Solo operation in the Options screen.

See Chapter 14, “Solo and Monitor Busses.”

Meter Bridge

The Meter bridge displays level for the currently chosen output type, as well as high-resolution Selected Channel meters for the currently selected channel.

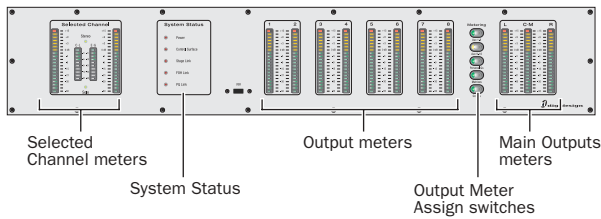

Meters, displays, and controls in the Meter bridge

Meters

The Meter bridge Output meters can be assigned to show Aux, Group, Mains, or other output levels. By default, output metering follows Output Fader assignment. You can also designate which output type to display in the Output meters.

 See Chapter 13, “Metering.”

System Status Panel

The System Status Panel provides LEDs that indicate the status of system communication. Use these LEDs to confirm connections and communication between components, and for troubleshooting.

When all components are communicating properly, the Status LEDs light green. If any Status LEDs are flashing, or red, it indicates possible problems with that component of the system.

 See Chapter 27, “Troubleshooting.”

Trackball and View Mode Controls

Trackball

The Trackball and its two switches are used to navigate on-screen.

View Modes

The View Mode switches (Inputs, Outputs, Filing, Snapshots, Patchbay, Plug-ins) display the corresponding pages on-screen. Pressing a View Mode switch repeatedly cycles through the individual tabs of that page. For example, pressing the Patchbay switch once displays the Patchbay screen. Pressing Patchbay again cycles through various tabs within the Patchbay page.

Chapter 4: Basic Commands and Modes

Control Overview

Most D-Show features and controls that are used during a performance are available from both the control surface and on-screen. Changes made on one are immediately reflected in the other, letting you use almost any combination of control surface and screen controls to mix.

The software screen is not required in order to mix a performance, as all mixing controls are provided on the control surface. However, the screen is essential when setting up and configuring the system before a performance.

Software-Only Controls and Displays

Many configuration settings and options are only available on-screen. These controls include hardware configuration settings, bus options, plug-in installation, and system diagnostics. For more information, see “System Configuration” on page 47.

Software Screen Banner Display

The software screen provides a banner display in the lower left corner. This display is provided to maintain line-of-sight mixing by showing the currently adjusted parameter (such as fader level or compression threshold) as you make changes to the parameter. The banner display also provides Tool Tip text and status messages.

Tool Tips

With the Trackball, place the cursor over a screen item to display a brief explanation of that item in the banner display.



Tool Tip

Status bar showing Tool Tip

Status Messages

The banner display alerts you to certain operating conditions such as Multi-Select and Multi-Assign modes.



Banner display

Mode display

Banner display showing current state of the system

Control Surface and Software Screen Linking

The software screen is linked to control surface actions by default. For example, touching an input channel fader on the Main Unit or a Sidecar changes the screen to Inputs page, and touching an output bus fader changes the screen to the Outputs page.

You can customize how D-Show targets channels on the Assignable Channel Section to best match your working style. For more information, see “Interaction” on page 53.

Config Mode and Show Mode

D-Show has two main operating modes, Config Mode and Show Mode. Use Config mode to set up your system and options; use Show mode to mix your performance.

Config Mode

Config mode provides access to the configuration settings that are typically performed as part of system setup (before mixing). For example, you must be in Config mode to do any of the following:

- Choose a Main mix format (L-R+M, or L-C-R)
- Designate the number and mono/stereo format of available auxes and groups, combine two mono channels into one stereo input channel, or split a stereo input channel into two mono channels.
- Install plug-ins
- Assign plug-ins in the D-Show software racks
- Route side-chain inputs to plug-ins
- Initialize (or reset) hardware devices and options
- Customize soloing, metering, and Talkback/Com routing
- Customize control surface and software interaction
- Move channels to different fader strips
- Perform system tests and diagnostics

⚠ *Some Config mode operations interrupt audio throughput.*

Show Mode

Show mode is the main operating mode for D-Show. All mixing and routing features are available, based on your settings for Config mode options.

Toggling D-Show Between Config Mode and Show Mode

To toggle D-Show between Config mode and Show mode, do one of the following:

- Press the Console Config switch (located at the upper right of the Assignable Channel Section).
– or –
- Double-click the Mode display in the Status Bar, located in lower-right hand corner of the screen.

Global Modifier Switches

D-Show provides a set of global modifier switches, located at the lower left corner of the Sidecar and Main Unit: Multi-Select, Default, Fine, and User.

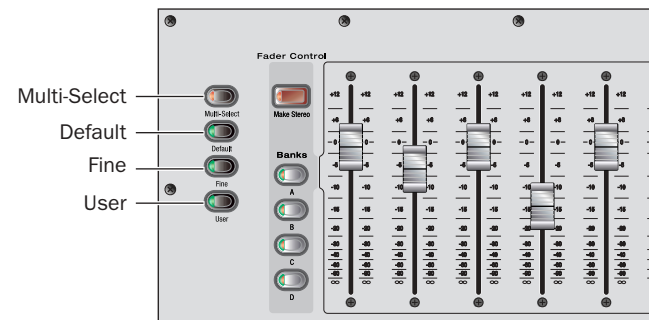

Global modifiers

These switches provide frequently used shortcuts that can be applied to control surface actions and software screen interactions.

Multi-Select Switch

The Multi-Select switch lets you select multiple Input Channels and then apply an action to all selected channels. Multi-Select is useful for batch routing and assignment of input channels.

Most channel functions support Multi-Select (or Multi-Assign) as noted throughout this guide. For details on how to select one or more channels, see “Selecting and Targeting Channels” on page 41.

Default Switch

The Default switch provides a quick way to reset a control to its default setting (or “zero” the setting). It is equivalent to, and interchangeable with, the Alt key on the keyboard.

Examples of Using Default

To reset a fader to 0 dB:

- 1 Press and hold the Default switch.
- 2 Press the Select switch on the channel you want to reset.

To reset all EQ parameters on a channel:

- 1 Press and hold the Default switch.
- 2 Press the EQ In switch (use the channel strip EQ In, or the ACS EQ In switch if the channel is currently selected in the ACS).

To reset a single EQ parameter:

- Hold the Default switch and press the encoder or switch for that parameter.

To reset Threshold on-screen:

- 1 Select an input or output channel on-screen.
- 2 Do one of the following:
 - Right-click the Threshold encoder on-screen and choose Reset.
 - or –
 - Hold the Default switch on the control surface and click the Threshold encoder on-screen.

 To reset a parameter using only the keyboard and trackball, press **Alt**+the on-screen control.

Fine Switch

The Fine switch lets you adjust controls (except for faders), on the control surface or on-screen, with maximum resolution. For example, if by default a controls adjusts a parameter in units of 1 dB, the Fine switch lets you adjust in units of 0.1 dB.

To adjust a control with fine resolution:

- Press and hold the Fine switch while moving a control. The display associated with the adjusted control will show the values changes at the corresponding resolution.

Momentary and Latching Modes

The Fine switch supports momentary and latching operation.

Momentary In momentary mode, the Fine switch stays in effect for as long as you hold down that modifier switch.

Latching In latching mode, the Fine switch stays in effect until you explicitly clear its active state.

To use the Fine switch in Momentary mode:

- 1 Press and hold the Fine switch.
- 2 Adjust a channel, parameter, or processor.
- 3 Release the Fine switch.

To use the Fine switch in latching mode:

- 1 Double-press the Fine switch. The switch LED lights.
- 2 Select or adjust one or more channels, parameters, or processors.
- 3 Press the Fine switch again to exit latching mode.

User

The User switch is reserved for future use.

Software Screen Pages and Tabs

Viewing Pages

To view a page, do one of the following:

- Press a View mode switch (located at the bottom right of the ACS).
- or –
- Click the page name at the top of the screen.

When additional tabs are available for a page, go to those tabs by clicking their names.

Click page name to display



Viewing pages

Overview of Software Pages

The software screen provides the following pages and tabs.

Inputs

Select, name, configure, and adjust parameters for input channels and FX Returns.



Inputs page (analog input shown)

See Chapter 7, “Inputs and Input Routing.”

Outputs

Select, name, configure, and adjust parameters for outputs.



Outputs page

See Chapter 8, “Outputs and Output Routing.”

Filing

Load, save, and transfer shows and presets.

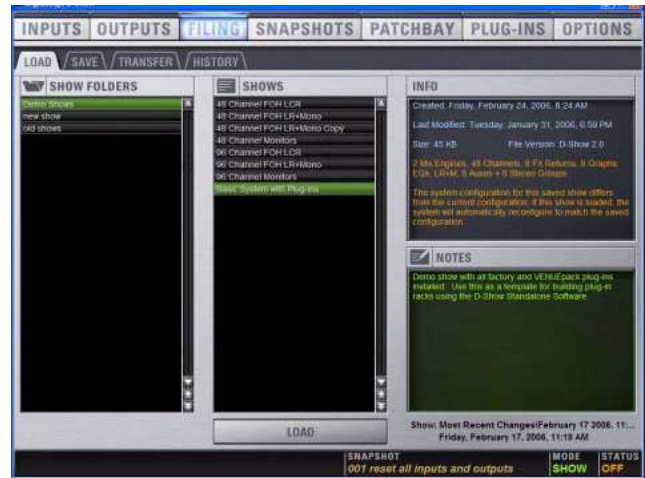

Filing (Load tab)

See Chapter 20, “Shows and File Management.”

Snapshots

Store and recall snapshots.



Snapshots page

See Chapter 21, “Snapshots.”

Patchbay

Route and name physical inputs and outputs to control surface channels.



Patchbay (Inputs tab)

See Chapter 12, “Patchbay.”

Plug-Ins

Configure and arrange plug-in racks by assigning plug-ins; patch/route and manage plug-ins.



Plug-In page

See Chapter 19, “Plug-Ins.”

Options

Configure control surface, Main busses (L-R+M, L-C-R), customize/optimize targeting, metering, modes, devices, install plug-ins, and set other system options.



Options page (System Config tab)

See Chapter 6, “Options.”

Chapter 5: Navigating and Selecting Channels

Banking Input Channels and FX Returns

Many D-Show configurations utilize more physical inputs than input faders. For example, a standard D-Show system provides up to 48 discrete hardware inputs and 24 input faders. To navigate to channels beyond the number of physical faders, D-Show provides channel *banking* controls.

The Bank switches move the display of channels on the control surface through other available banks.

- Input Channels are banked using the Bank A, B, C, and D switches, located to the left of the input faders on both the Main Unit and Sidecars.
- FX Returns are banked using the FX Returns switches, located to the right of the eight input faders on the Main Unit.

By default, fader banking is global across all units but you can configure D-Show for split (or “local”) banking of faders as well as encoders.

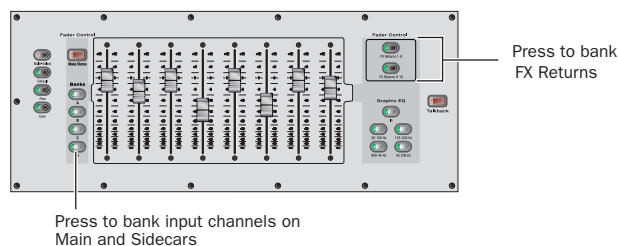

Bank switches for inputs

To bank Input Channels to the input faders:

- Press the appropriate Bank switch (A, B, C, or D).

To bank FX Returns to the Main Unit:

- Press a Fader Control switch (FX Returns 1–8, or FX Returns 9–16).

When you press the Bank switches (A, B, C, D) on any Sidecar (no the Main Unit), FX Returns will remain banked to the Main Unit input faders. This lets you have input and FX Returns available simultaneously.

 *Flip mode can be used to put Aux send level at Sidecar Input faders, leaving Main Unit input faders to control their FX Return level.*

To bank Input Channels while keeping FX Return channels on the Main Unit input faders:

- Press any of the Bank switches (A, B, C, D) on any Sidecar.

To return the Main Unit input faders to Input Channel banking, do one of the following:

- Press a lit FX Returns switch (1–8 or 9–16).
– or –
- Press any of the Bank switches (A, B, C, D) on the Main Unit.

Main and Sidecar Split Banking

You can link or unlink fader banking and/or encoder assignment across Main and Sidecar units.

- ◆ Unlinking Main and Sidecar banking lets you leave key channels available on one section of the control surface, while maintaining the ability to access other channels as needed within another section of the control surface.
- ◆ Unlinking encoder assignment lets you assign encoder functions locally, per Main or Sidecar unit.

Faders and encoders can be linked or unlinked as separate functions, giving you four possible configurations:

- Faders linked, encoders linked (the default setting)
- Faders unlinked, encoders linked
- Faders linked, encoders unlinked
- Faders unlinked, encoders unlinked

If more than one Sidecar is connected, each Sidecar functions independently (locally) when unlinked.

 *The Multi-Select, Default, Fine and Make Stereo switches remain linked between Main and Sidecar units regardless of Fader Bank or Encoder link status.*

 *The Aux Follows AFL switch toggles only the Main unit encoder assignments when units are unlinked (Sidecar encoder assignments are unaffected).*

Link status can be changed at any time (in both Config and Show modes) and settings are stored in the Show file.

To link or unlink fader banks from the control surface:

■ Press and hold for two seconds any fader bank button on the Main unit or any Sidecar. All four Bank buttons and the Source button flash when link/unlink occurs. When linking, bank selection follows the unit the linking was initiated from

To link or unlink encoders from the control surface:

■ Press and hold for two seconds any encoder assignment button on the Main unit or any Sidecar. All encoder assign buttons (except Flip) flash when you link or unlink.

💡 *The encoder Flip switch does not support control surface linking/unlinking. Use any other encoder assignment switch.*

To link or unlink fader banks and/or encoders on-screen:

- 1 Go to the Options page and click the Interactions tab.
- 2 In the Control Surface section, click to configure the options for Fader Banks and Encoders link status as desired.



Options > Interaction page, Control Surface linking settings

Relinking

When you relink units from the Options > Interaction screen, all Sidecars conform to the current Main Unit input fader bank assignment. If the Main Unit is currently banked to GEQ or FX returns it automatically reverts to Input fader bank mode when units are relinked.

If you relink using the Fader Bank switches on the control surface, target and selection of other units follows the unit on which you perform the relink command (Main or Sidecar).

Banking Graphic EQ Frequency Bands

When a built-in Graphic EQ is inserted on the currently targeted output or bus, its frequency bands can be banked to the eight Input faders on the Main Unit.

📖 See Chapter 17, "EQ."

Banking the Assignable Output Encoders and Assignable Output Faders

Outputs can be targeted and banked to the Assignable Output Faders (AOFs) or to the Assignable Output Encoders (AOEs). These two sections can target independently, letting you view and control two banks of eight outputs simultaneously, as available in each control section, as follows:

Assignable Output Encoders These can target Auxes 1–8, Auxes 9–16, Groups (or Variable Groups), Matrix mixer inputs, or PQ mixer inputs.

Assignable Output Faders These can target Auxes 1–8, Auxes 9–16, Groups (or Variable Groups), Matrix mixer outputs, PQ mixer outputs, or VCAs.

To assign Aux, Group (or Variable Group), Matrix, or PQ controls to the Assignable Output Encoders:

- Press Encoder Assign switch, located to the right of the Output Encoder row.

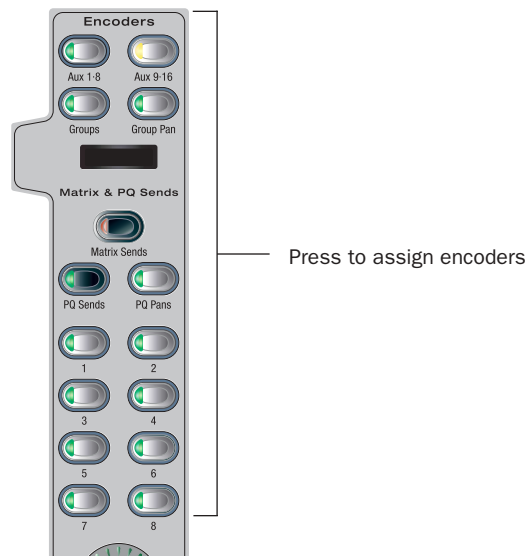

Assignable Output Encoder controls

To assign Aux, Group (or Variable Group), Matrix, PQ, or VCA controls to the Assignable Output Faders:

- Press the corresponding switch in the Output Faders section. Choices are Aux 1–8, Aux 9–16, Personal Q, Matrixes, Groups, and VCAs.

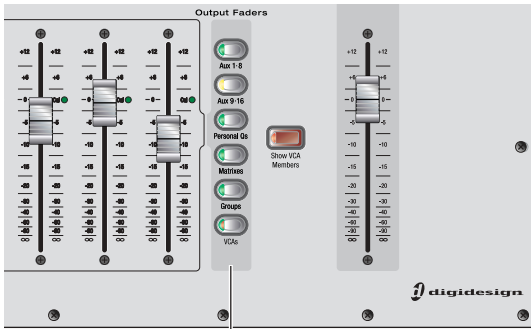

Press to assign faders

Bank switches for Output channels

Selecting and Targeting Channels

Each D-Show channel strip has a channel Select switch. The Select switch targets that channel for routing or processing assignment. Channels can also be selected by clicking their fader strips on-screen.

When a single channel is selected, it becomes the targeted channel. The fader level and all other parameters of targeted channel can be adjusted from the ACS or from the selected channel controls on-screen.

To select a channel, do one of the following:

- Press the Select switch on the control surface channel strip.
- OR –
- Click anywhere in the on-screen channel fader strip, except on the fader, mute, solo or safe buttons.

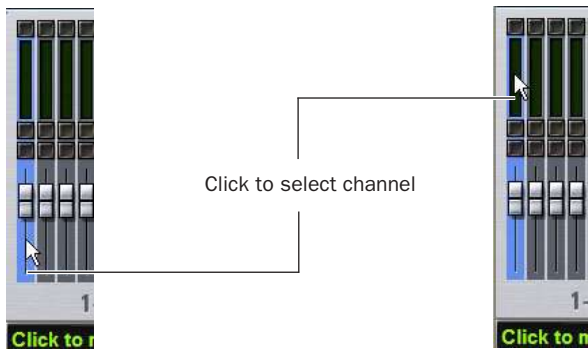

Clicking on-screen to select a channel

Multi-Select

Multi-Select lets you select multiple channels in order to apply an action to them in one step.

Multi-Select only applies to channels. To select multiple snapshots or other named items, use the Shift key on the keyboard.

To select multiple channels from the control surface:

- 1 Press and hold the Multi-Select switch (located above the input Bank switches). The switch flashes to indicate Multi-Select mode.
- 2 Press Select on each channel you want to include in the selection.
- 3 Release the Multi-Select switch.
- 4 Perform a routing assignment or other function (for example, press a Bus Assign switch on one of the included channels). The operation is applied to all selected channels.

You can use the Shift key on the keyboard in place of the Multi-Select switch to select multiple channels.

To exit Multi-Select mode, do one of the following:

- Press Cancel.
- OR –
- Press the Select switch on a channel that is currently not selected.

To select multiple channels on-screen:

- Press and hold the Multi-Select switch (or hold Shift on the keyboard) and click the fader strips on-screen.

To select an 8-channel bank on-screen:

- Click the bank name below the on-screen fader strips.



Clicking a bank display to select multiple channels on-screen

To select all input channels or all output channels on-screen:

- Double-click any bank name below the on-screen fader strips in the Input or Outputs screen.

To remove a channel from a selection:

- Control-click a highlighted channel.

See “Screen Controls and Shortcuts” on page 43 for additional on-screen features.

Multi-Assign

There are two types of Multi-Assign switches on D-Show, as follows:

ACS Bus Assigns The Multi-Assign switch in the ACS Bus Assigns section is used to route channels to the Main and Group busses.

Assignable Output Faders The Multi-Assign switch on each Assignable Output Fader is used to route channels to Output busses or VCAs.

Using Multi-Assign to Route Channels to Main or Group Busses

To route multiple channels to any number of Main or Group busses:

- 1 Target the first channel you want to route to the Main or Group busses by pressing its Select switch.
- 2 Press the Multi-Assign switch in the ACS Bus Assigns section.
- 3 Press the Select switches on the other channels you want to route to a Main or Group bus.
- 4 In the ACS Bus Assigns section, press any of the Main or Group bus switches so that they are lit.
- 5 Press the flashing Multi-Assign switch to confirm the assignment, or press the Cancel switch to cancel the assignment.

Using Multi-Assign to Route Channels to Output Busses

To assign multiple channels to an Aux, Group (or Variable Group), or VCA:

- 1 Press one of the following switches in the Output Fader assignment section:
 - Aux 1–8
 - Aux 9–16
 - Groups
 - VCAs
- 2 Press the Multi-Assign switch above the Assignable Output Fader where you want to make the assignment. The flashing Multi-Assign switch and the banner display at the lower left of the screen indicate that Multi-Assign mode is enabled.
- 3 Press the Select switches on the channels you want to assign to the Aux, Group (or Variable Group) or VCA.
- 4 Press the flashing Multi-Assign switch to confirm the assignment, or press the Cancel switch to cancel the assignment.

 See Chapter 8, “Outputs and Output Routing.”

Type Text Search

Type Text search lets you use the keyboard for fast navigation to a channel or snapshot. You can enter the first characters of a channel name or the absolute channel number to target that channel on the ACS. (See also “Selecting and Targeting Channels” on page 41.)

To search for and select a channel by name:

- 1 Go to the Inputs, Outputs, or Patchbay page.
- 2 Type the first few letters, channel number, or full name of the channel. For example, type “s” to go to the first channel beginning with the letter s (such as Snare).
- 3 Press the Tab key to cycle through and select any other channels beginning with that letter (such as *Snare Top*, *Snare Bottom*, or *Strings*).

Channel Numbers and Names

D-Show channel numbers are “absolute” channel numbers. Renaming changes the displayed name associated with each channel, but the absolute channel number remains fixed.

To search for and select a channel by absolute number:

- Type a number on the alphanumeric to select the corresponding channel.



Type Text search can also be used to select snapshots in the Snapshots page. See Chapter 21, “Snapshots.”

Targeting Plug-In Inserts

Selecting a single channel targets that channel in the ACS. This lets you use the ACS and Assignable Output Encoders to adjust controls in plug-ins inserted on the targeted channel.

To target a channel in the ACS:

- Press the channel Select switch.

To adjust a plug-in on the ACS target channel:

- 1 Press a Select switch in the Insert Processing section of the ACS.
- 2 Press the Insert Mode switch. Plug-In parameters appear on the Assignable Output Encoders.



See Chapter 19, “Plug-Ins.”

Screen Controls and Shortcuts

Adjusting On-Screen Faders

You can move on-screen faders independently or in ganged fashion.

To move a single fader on-screen, do one of the following:

- Drag a fader in the on-screen channel strip section at the bottom of the screen.
- or –
- Select a channel and move its fader in the on-screen selected channel controls.

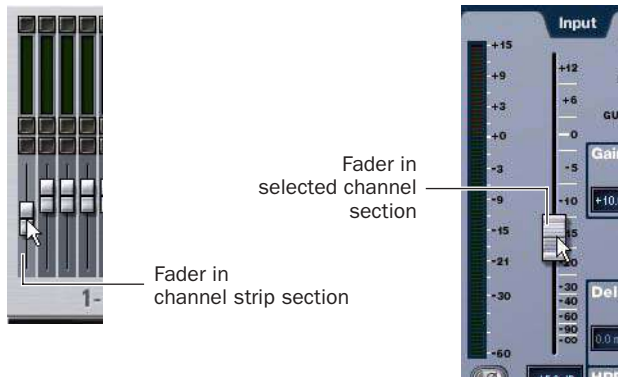

Dragging a fader on-screen

To move multiple faders on-screen in ganged fashion:

- 1 Select multiple channels on-screen by Shift-clicking them.
- 2 Move the fader on one of the selected channels.

The faders on the selected channels will move in ganged fashion. Any offset between the faders is maintained until at least one of the faders is zeroed (moved to $-INF$) or maxed (set to $+12$ dB).

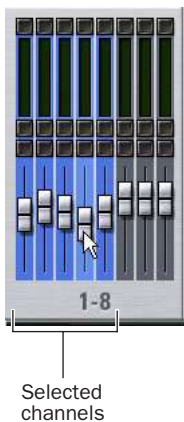

Dragging multiple faders on-screen

Adjusting On-Screen Encoders

You can adjust on-screen rotary encoders by dragging directly over the on-screen knob.

To adjust an on-screen rotary encoder:

- 1 Click on the knob so that it is highlighted.
- 2 Drag up to turn the encoder clockwise; drag down to turn the encoder counter-clockwise.



Dragging over an encoder on-screen

Adjusting Values On-Screen

In addition to typing numeric values in text boxes, you can adjust parameter values and numeric option settings on-screen by dragging directly over the corresponding text box.

To adjust a value on-screen by dragging:

- 1 Click in the text box to select the value.
- 2 Drag up to increase the value; drag down to decrease the value.



Adjusting a parameter value by dragging over its text box

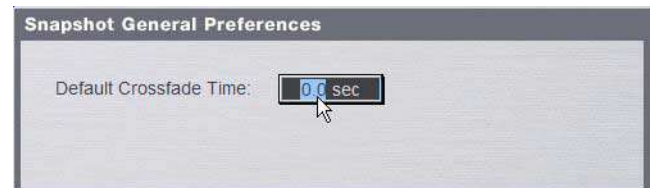

Adjusting an option setting by dragging over its text box

Fader Shortcuts

The on-screen Fader display provides the following right-click shortcuts.

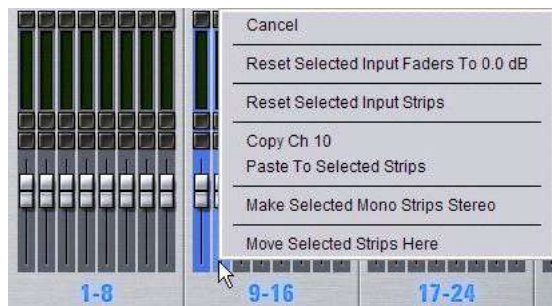

Right-clicking a fader on-screen

Reset Fader

Resets the fader position to zero.

Reset

Resets every parameter on the selected channel(s) to default settings.

Copy and Paste Channel

Channel settings can be copied in their entirety from one channel and pasted to one or more channels from the console or on-screen.

To copy and paste channel settings from the control surface:

- 1 Press the Select switch on the channel you want to copy.
- 2 Press F3 to copy.
- 3 Press the Select switch on one or more destination channels (the channel or channels to which you want to paste the copied settings).
- 4 Press F4 to paste.

To copy and paste channel settings on-screen:

- 1 Do one of the following:
 - Right-click on a channel fader in the fader display across the lower half of the screen and choose Copy.
 - or –
 - Right-click within the upper channel display and choose Copy.

 *You do not need to select the channel before copying its settings on-screen.*

- 2 Select one or more destination channels. You can only paste to selected channels.

- 3 Right-click on the lower fader strip on-screen, or on any non-control area of the destination channel, and choose Paste to Selected Strip(s).



Pasting channel settings

Parameters and Channel Types

Input channels can only be copied or pasted to other Input channels. Output channels can only be copied or pasted to other channels of the same type (such as Aux, Group, PQ, Matrix). When pasting channel settings:

- Settings common to the source and destination channel are always pasted.
- Copied settings with no corresponding parameter in the destination channel are ignored.
- Settings in the destination channel with no corresponding parameters are left unchanged.

Copying and Pasting Mono and Stereo Channel Settings

You can copy a mono channel and paste its settings to one or more stereo channels. Mono settings are applied equally to the left and right channels of the stereo destination. The stereo destination channel retains its current balance and width settings.

You can also copy a stereo channel and paste its settings to one or more mono channels. The left channel settings of the stereo source are applied to the mono channel(s). The mono destination channel retains its current pan setting.

Settings Excluded from Copy and Paste

Input Channels The following Input channel parameters are not copied or pasted (the current settings of the destination channels are retained):

- Patchbay assignments, including Direct Outs
- Channel Name
- Hardware and software insert (plug-ins) assignments and in/out state.

Output Channels The following Output channel parameters are not copied or pasted (the current settings of the destination channels are retained):

- Patchbay assignments, including Direct Outs
- Channel Name
- Hardware and software insert (plug-in) assignments and in/out status
- GEQ settings
- Output membership (the assignment of channels to an Aux, Group VCA, Matrix or PQ).

 *To copy GEQ settings, use the copy/paste GEQ shortcut or use GEQ Presets. Use the Replace with Mix (members) From command to replace output membership for an Aux, Group, VCA, Matrix or PQ.*

Make Selected Mono Strips Stereo/Make Selected Stereo Strip Mono

Combines two selected mono channels into a single stereo channel, or splits a selected stereo channel into two mono channels. D-Show must be in Config mode to change the stereo status of a channel.

Move Selected Strip

Moves a selected strip from its current position to a new location. D-Show must be in Config mode to move channel strips.

To move a fader strip:

- 1 Put D-Show in Config mode.
- 2 Select the channel you want to move.
- 3 On-screen, right-click on the strip where you want to move the selected channel.
- 4 Choose Move Selected Strip Here from the pop-up menu.

Channel Control Shortcuts

The on-screen channel faders and encoders provide the following right-click shortcuts to reset individual parameters and channel strips.



Right-clicking channel strip controls on-screen

Reset Parameter

To reset an on-screen fader or encoder to its default value, do one of the following:

- Right-click the control and choose Reset.
 - or –
- Alt-click the control.

Reset Channel

To reset an entire channel strip to its default settings:

- Right-click the on-screen channel fader and choose Reset Strip.

Chapter 6: Options

Overview of Options

The Options page provides the following tabs:

- System Config (see “System Configuration” on page 47)
- Busses (see “Busses” on page 50)
- Pickoffs (see “Pickoffs” on page 52)
- Snapshots (see “Snapshots” on page 52)
- Miscellaneous (see “Misc” on page 53)
- Interaction (see “Interaction” on page 53)
- Devices (see “Devices” on page 50)
- Plug-Ins (see “Installing and Authorizing Plug-Ins” on page 145)

To display the Options page, do one of the following:

- Press the Options switch in the View modes section of the Main Unit.
- or –
- Click the Options tab on-screen.

The System Configuration and Devices screens provide the primary tools by which you configure D-Show mixing, routing, and processing options.

System Configuration

The System Config page lets you allocate DSP resources used for routing and processing, configure the Main and Aux/Group busses, clear the console, and quit (shut down D-Show).

To access the System Config page:

- Go to the Options page and click the System Config tab.

Editing System Config Settings

Settings available in the System Config screen can only be edited while in Config mode.

! Changing the system configuration will restart the D-Show software and may interrupt audio.

In Config mode, the Edit button becomes available to let you change settings. When a System Config setting is changed, the Apply button becomes available at the right of the screen to let you confirm and apply changes.

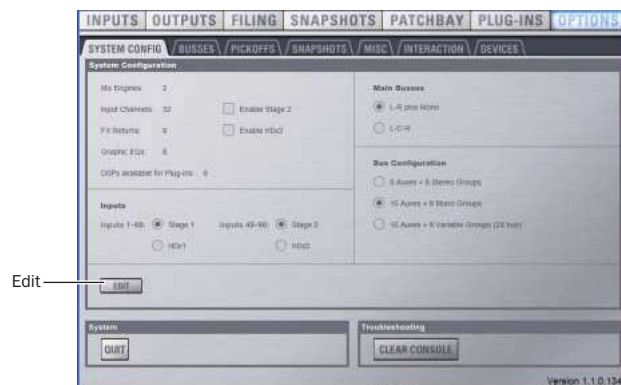

System Configuration tab of the Options page

In Show mode, the Edit button is unavailable. This protects these settings from being changed during a performance (since changes to these settings can interrupt audio).

System Configuration settings on a standard D-Show system

Input Channels	FX Returns	Graphic EQs
32, 48, 64, or 96	8 or 16	0, 8, 16, or 24

To change a System Config option:

- 1 Put D-Show in Config mode.
- 2 Go to the Options page and click the System Config tab.
- 3 Click Edit.
- 4 Change a System Config, Main Bus, or Bus Configuration option.
- 5 Click Apply to confirm and apply your new settings.

System Configuration Settings

The System Configuration section shows DSP and other resources currently available. Available configurations depend on the number of Mix Engine cards in your system (see “Devices” on page 50).

In Show mode, the System Config area is display-only. In Config mode, you can allocate resources for mixing, routing, and processing.

To change a System Configuration setting:

- 1 Put D-Show in Config mode.
- 2 Click the Edit button on-screen.
- 3 Choose a new setting for Mix Engines, Channels, FX Returns, or Graphic EQs.
- 4 Click Apply to confirm the settings.



Designating the number of Input Channels

Mix Engines

On a complete D-Show system, the Mix Engine setting is determined by the number of DSP Engine Cards detected and cannot be changed.

 *Mix Engine allocation can be edited in the D-Show Standalone software, letting you pre-configure a Show file off-line then transfer the Show to a D-Show system. See Chapter 23, “Using the D-Show Standalone Software.”*

Channels

Choose the total number of Input Channels you need. This number represents mono channels; each stereo channel uses two mono channels.

Available choices will vary depending on the number of Mix Engine cards and resources available on your system. With a standard system containing two Mix Engine cards, you can choose 32, 48, 64, or 96 Input Channels.

Choosing a lower number of Input Channels leaves more DSP for plug-ins; choosing a higher number reduces the amount of DSP available for plug-ins.

FX Returns

Choose the number of FX Return channels you need. You can choose to have 8 or 16 stereo FX Return channels. Choosing the lower number leaves more DSP for plug-ins; choosing the higher number reduces the amount of DSP available for plug-ins.

Graphic EQs

Choose the number of Graphic EQs you will need for output processing. You can choose to have 0, 8, 16, or 24 Graphic EQs. Choosing a lower number leaves more DSP for plug-ins; choosing a higher number reduces the amount of DSP available for plug-ins.

DSPs Available for Plug-Ins

The amount of DSP available for plug-ins depends on your other System Config settings, and cannot be changed directly. To change the amount of DSP available for plug-ins, adjust other System Configuration settings:

To maximize the DSP available for plug-ins:

- Reduce the number of Channels, FX Returns, or Graphic EQs.

To increase the total amount of DSP available on your system:

- Add Mix Engine cards, disable the second Stage Rack, or reduce the number of Channels, FX Returns, or Graphic EQs.

Enable Stage 2

Lets you enable an (optional) second Stage Rack to increase the I/O capacity of the D-Show system.

Enable HDx2

Lets you enable an (optional) second HDx card to increase the I/O capacity of the TDM Record/Playback Option.

Input Settings

With the HDx TDM Record/Playback Option, you can replace Stage Rack inputs with fixed HDx card outputs. On systems with 2 Stage Racks and 2 HDx cards, you can replace the inputs from each Stage Rack independently.



Input source selectors in the System Config page

 See the HDx TDM Record/Playback Option Guide.

Main Bus Settings

The Main Bus Settings let you configure the Main mix bus. See “Configuring the Main Busses” on page 70.

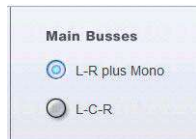

Main Buses options in the System Config page

L-R plus Mono

This default setting provides a stereo bus, plus one mono bus.

L-C-R

This setting enables L-C-R mode, which lets you mix in “3-across-the-front” mode.

 Changing the Main Bus mode will restart the D-Show software and may interrupt audio.

To change the Main Bus configuration:

- 1 Put D-Show in Config mode.
- 2 Go to the Options page and click the System Config tab.
- 3 Click Edit.
- 4 Click to choose a Main Bus mode.
- 5 Click Apply. D-Show restarts.

Bus Configuration Settings

The Bus Configuration Settings let you choose the D-Show Aux and Group busses configuration. See “Configuring Aux, Group, and Variable Group Busses” on page 70.



Bus Configuration in Config/Edit mode

To change the Aux/Group/Variable Group Bus Configuration:

- 1 Put D-Show in Config mode.
- 2 Click the Edit button on-screen.
- 3 Click to select a Bus Configuration option.
- 4 Click Apply. D-Show restarts.

Devices

The Devices page lets you view system connections, troubleshoot hardware and reset D-Show system components.

To display the Devices tab:

- Click Options > Devices.

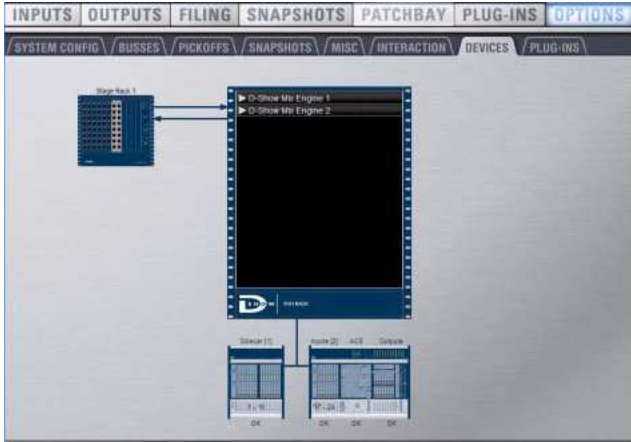

Devices tab of the Options page

On the D-Show system, you can use this page to update the system when adding expansion options, or to view component status after diagnostics or troubleshooting.

To reset D-Show system hardware components:

- 1 Put D-Show in Config mode.
- 2 Go to the Options page and click the Devices tab.
- 3 Right-click any of the following hardware components:
 - Inputs section of the Main Unit
 - ACS section of the Main Unit
 - Outputs section of the Main Unit
 - Sidecar
 - Stage Rack
- 4 Choose Reset.

Simulating a D-Show Configuration with the Standalone Software

With the D-Show Standalone software, you can use the Devices page to simulate a D-Show system of any size for purposes of preparing shows. See “Simulating a D-Show Configuration” on page 196.

Other D-Show Options

Busses

The Busses page lets you customize characteristics for the Aux, Variable Group, Solo, and Main busses.

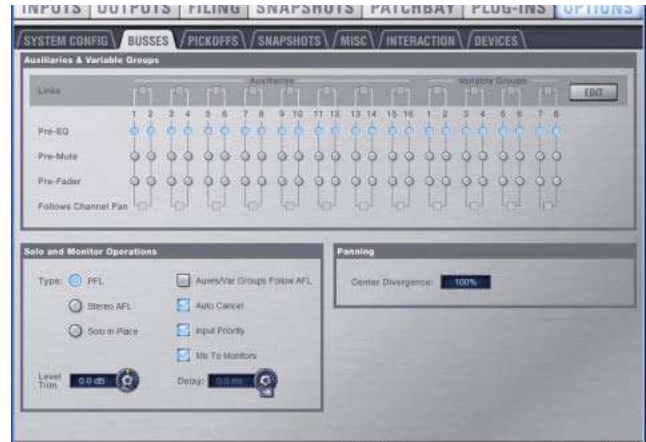

Busses tab of the Options page

Auxiliaries & Variable Groups

These options let you designate bus link status, pick off source, and stereo pan behavior.

 For more information, see Chapter 10, “Auxes and Variable Groups.”

Links When enabled, this option links the corresponding mono Aux or Variable Group busses into bus pairs. Control changes affect both mono Aux busses, and the Follows Channel Pan option becomes available.

Pickoff These options let you designate the pre-fader pickoff point feeding each Aux or Variable Group bus. Choices include pre-EQ, pre-mute, and pre-fader (post-mute).

Follows Channel Pan Each channel can be panned independently within each linked Aux or Variable Group bus pair, or configured to follow the channel pan by enabling the Follows Channel Pan option.

To change the Aux bus or Variable Group bus configuration:

- 1 Put D-Show in Config mode.
- 2 Go to the Options page and click the Busses tab.
- 3 Click Edit.
- 4 Configure the following settings:
 - To link two mono Aux busses or Variable Group busses into a bus pair, select the Link option for the corresponding pair.
 - Specify the panning for channels routed to Aux or Variable Group bus pairs by selecting or deselecting the Follows Channel Pan option.
 - Click to select the pickoff point for each bus (Pre-EQ, Pre-Mute, or Pre-Fader).
- 5 Click Apply to reconfigure the system.
 - or –
 - Click Cancel to exit without changing system settings.

Solo and Monitor Operations

These settings customize Solo and Monitor bus mode and operation.

 See Chapter 14, “Solo and Monitor Busses.”

Type Solo mode choices include PFL (Pre-Fader Listen), Stereo AFL (After-Fader Listen), and Solo-In-Place.

Auxes/Var Groups Follow AFL Causes the controls for an Aux Send or Variable Group Send to be automatically displayed on the Input Channel encoders whenever the AFL switch is pressed on the corresponding output bus.

Auto Cancel Soloing a channel strip automatically takes any currently soloed channels out of solo.

Input Priority Makes soloed inputs temporarily replace soloed output busses on the AFL/PFL bus.

Mix to Monitors Mirrors the functionality of the Mix to Monitors switch on the control surface.

Level Trim Mirrors the functionality of the Solo/PFL level control on the control surface

Monitor Bus Delay Mirrors the level and in/out functionality of the monitor bus delay controls on the control surface.



Solo controls in the Options > Busses page

To configure Solo settings on-screen:

- 1 Go to the Options page and click the Busses tab.
- 2 Configure settings as needed:

To adjust Monitor Bus Delay, do one of the following:

- Press and hold the control surface Delay switch, then rotate the Select encoder in the ACS.

 By default, Delay adjusts in fine increments. Press and turn the Selected encoder to adjust delay in coarse increments.

- Adjust the Delay encoder on-screen.
- Click the Delay value shown on-screen, and manually enter a new value.

To toggle Delay on or off, do one of the following:

- Press and release the Delay switch.
 - or –
- Click to toggle the Delay In switch on-screen.

 Delay settings are retained when toggled off or on.

Panning/Center Divergence

The Panning section provides control over center channel divergence when the Main Bus is set to L-C-R mode. See “Main Bus Center Divergence Options” on page 75.

To set Center Divergence:

- Enter a value or drag in the Center Divergence text box and press Enter.

Stereo Group Panning Operation

(Not Available in Variable Groups Mode)

The Stereo Group Panning Operation options provide different levels of flexibility for how channels can be routed to Groups.

 See Chapter 9, “Groups.”

To change Stereo Group Panning Operation:

- 1 Put D-Show in Config mode.
- 2 Click to select Simple or Expert mode.

Pickoffs

The Pickoffs page lets you control bus pickoff point on input strips, as well as specify source and insert points for output busses. The Pickoffs page also provides master control for D-Show Delay Compensation.

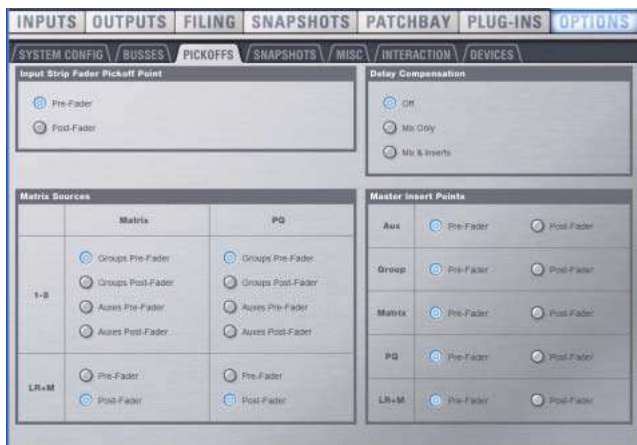

Pickoffs tab of the Options page

Throughout this guide, Pickoff options are explained where relevant.

Snapshots

The Snapshots page provides several snapshot preference settings to optimize D-Show Snapshot operation.



Snapshots tab of the Options page

Snapshot General Preferences

The following settings are available in the Snapshots page.

See Chapter 21, “Snapshots.”

Default Crossfade Time Defines the length of time it takes D-Show to crossfade between fader levels when recalling snapshots. Maximum crossfade time is 99.9 seconds.

PRE

The options in the PRE section let you specify which parameters are recalled with Snapshots whose scope includes Pre settings. Click to toggle whether recalled Input snapshot data includes the following:

- Gain, Pad, and Phase
- +48V (phantom power)
- HPF

Lightbulb icon: Delay is stored as a unique (discrete) data type for each channel.

Aux Mon and Aux FX

These settings let you classify individual Aux Sends or Variable Group Sends (or linked bus pairs) as monitor sends (“Mon”) or as effects sends (“FX”), which lets you scope each type separately from the Snapshots page.

This option is for organizing Aux Sends and Variable Group Sends for snapshot control only, and does not directly affect Aux bus or Variable Group bus operation.

MTC (MIDI Time Code)

The MIDI Time Code options let you control MTC operational modes, frame rate, and Start Time.

Modes Available MTC modes are MTC Off, MTC Read (slave), and MTC Generate (master).

Frame Rate This option sets the frame rate that is used when generating MTC.

Start Time This option sets the start time that is used when generating MTC.

MIDI

Designates the channel on which snapshots send or receive MIDI Bank Select and Program Change information.

See Chapter 22, “Synchronization.”

Snapshots Send on Channel This option sets snapshots to send Bank Select and Program Change commands on selected MIDI channel.

Snapshots Respond to Channel This option sets snapshots to respond to incoming Bank Select and Program Change commands on the selected MIDI channel.

MIDI Snapshot Output Safe Safes (shuts off) D-Show MIDI output when snapshots are recalled. This does not affect sending of Bank Select and Program Change commands with the Snapshots Send on Channel option.

Misc

The Miscellaneous page provides utility and other settings.

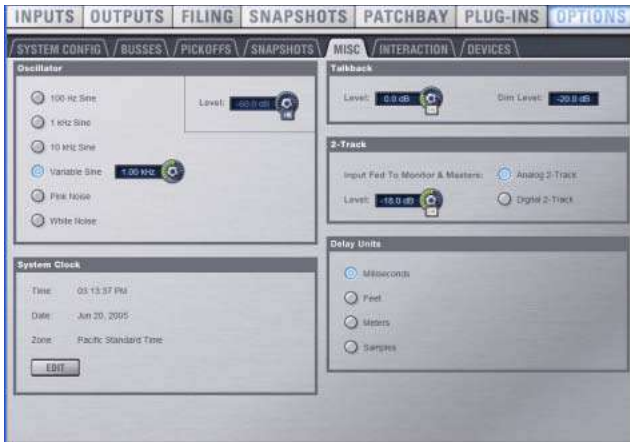

Misc tab of the Options page

Oscillator

Lets you choose the tone, frequency, and level for the built-in oscillator.

While the Oscillator is set to Variable Sine, pressing the Osc encoder momentarily changes the Osc encoder function from level to frequency.

System Clock

Sets the date and time for the system.

Talkback

Talkback Level Lets you activate Talkback and set Talkback input level.

Talkback Dim Level Sets the dim level, or amount of attenuation applied to the mix on the output bus when Talkback is activated.

2-Track

2-Track Level Lets you activate 2-Track input and set 2-Track input level.

2-Track Input Selects which 2-Track input (analog, or digital) is fed to the monitors and output busses.

Delay Units

Lets you set the display units on all applicable input and output delay controls. This makes it possible to set the delay based on any of the following:

- delay time (in milliseconds)
- distance to the source (in feet or meters)
- number of samples of delay

Interaction

The Interaction page lets you configure the Assignable Channel Selection, Input Safe Switches, Foot Switch, Meter, and LCD Display options.

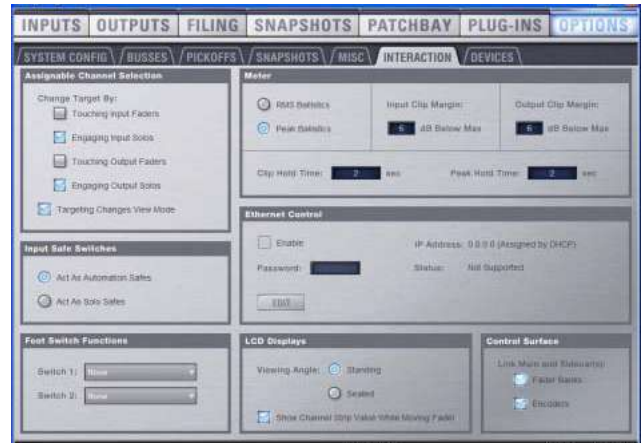

Interaction tab of the Options page

Assignable Channel Selection

Options in this section set the mechanism by which channels are targeted on the ACS.

To customize D-Show control surface and screen interaction:

- 1 Go to the Options page and click the Interaction tab.
- 2 Set the following Assignable Channel Selection options:

Change Target By

The Change Target By options let you specify whether the following actions target the affected channel on the ACS. More than one option can be selected simultaneously.

- Touching Input Faders
- Engaging Input Solos
- Touching Output Faders
- Engaging Output Solos

Targeting Changes View Mode

The Targeting Changes View Mode option updates the on-screen display to show the page for the channel targeted in the ACS. When this option is deselected, the on-screen display does not update when a channel is targeted on the ACS.

Input Safe Switches

The Input Safe Switches let you control two independent Safe functions: Automation Safe and Solo Safe. Only one of these Safe functions can be viewed and controlled at a time.

Act as Automation Safes When selected, this option sets the Safe switches (on the control surface Input Channels and FX Returns) and Safe buttons (on all on-screen channels) to toggle the Automation Safe status of the corresponding channel. You can also use Safe Selected mode to toggle the Automation Safe status of any channel. See “Automation Safing Channels” on page 178.

Act as Solo Safes Solo Safe applies only to Input Channels and FX Returns. When selected, this option sets the Safe switches (on the control surface and on-screen) to toggle the Solo Safe status of the corresponding channel. See “Solo Bus Operation” on page 111.

Footswitch Functions

Two Footswitch inputs are provided on the back panel of the D-Show Main Unit. The Footswitch options let you set the function of Switch 1 and Switch 2 to a variety of different snapshot, solo, talkback, and mute functions.

Choices for Footswitch 1 and Footswitch 2 include:

- Recall Next Snapshot
- Recall Previous Snapshot
- Recall Selected Snapshot
- Target Next Strip
- Target Previous Strip
- Clear Solos
- Flash LittLites
- Toggle Talkback Button
- Mute All Stage Outputs
- Toggle Mute Group 1
- Toggle Mute Group 2
- Toggle Mute Group 3
- Toggle Mute Group 4
- Toggle Mute Group 5
- Toggle Mute Group 6
- Toggle Mute Group 7
- Toggle Mute Group 8
- Toggle Encoder 1 Flip to Faders
- Toggle Encoder 2 Flip to Faders

Meters

Metering settings provide the following options for meter ballistics, peak, and clip indication.

Ballistics This option lets you choose RMS or Peak ballistics for the control surface and on-screen meters.

Input Clip Margin and Output Clip Margin These options set the level, relative to the maximum (full scale) level, at which a clip is reported on a channel. When a clip is detected, the entire channel meter turns red.

To set Input or Output clip margin:

- 1 Click in the “dB Below Max” edit box for Input Clip Margin or Output Clip Margin.
- 2 Enter a value or drag to change the value and press Enter.

The entered value is interpreted as a relative dB value from the maximum (where “Max” is considered +20 dBVU). For example, with the Input Clip Margin set to 6 dB below max (the default), peak levels within 6 dB of maximum level will trigger a clip indication

Clip Hold Time and Peak Hold Time These options specify how long clips and peaks are held. Default is 2 seconds for both Clip and Peak hold.

Ethernet Control

Ethernet Control settings let you configure the D-Show ECx Ethernet Control option (purchased separately) to allow remote control of D-Show over a wireless Ethernet network.

 See the *ECx Ethernet Control Option Guide*.

LCD Displays

These options let you customize the behavior of the control surface LCDs.

Show Channel Strip Value While Moving Fader This option determines what is displayed in the Channel Name display when a fader is adjusted.

When selected (default), the Channel Name display switches from showing channel name to showing the value (level) when a fader is adjusted. When deselected, the Channel Name displays do not show values when a fader is adjusted.

Viewing Angle This option lets you configure the LCD displays for optimum viewing.

Control Surface

These options let you link or unlink faders and encoders across Main and Sidecar units.

Link Main and Sidecars These options provide separate link states for faders banks and encoders. When selected, fader banks (or encoders) bank and assign globally across all units. When deselected, faders can be banked locally to each unit (Main or Sidecar), and encoders can be assigned uniquely on each unit.

Plug-Ins

The Plug-Ins tab of the Options page is used to install plug-ins on the D-Show system. The Plug-Ins tab is available on complete D-Show systems only. It is not available in the D-Show Standalone software. See “Installing and Authorizing Plug-Ins” on page 145.

Part III: Signal Routing

Chapter 7: Inputs and Input Routing

Configuring Inputs

Types of Inputs

Two types of inputs are available: Input Channels and FX Returns.

Input Channels

Input Channels are used to control inputs from the Stage Rack, FOH Rack, or Pro Tools playback options. (Bus-fed plug-ins can also be routed to Input Channels.) Input Channels can be mono or stereo. Each mono channel controls one input, and each stereo channel controls two inputs in tandem. Input Channels can appear on any of the input channel strips on the Main Unit or Sidecars.

Input Channels are displayed in banks on the control surface input channel strips. The number of channels in a bank depends on the number of Sidecars in the system.

FX Returns

Effects Return channels (or *FX Returns*) are used to control return signals from bus-fed plug-ins, or from hardware inputs on the Stage Rack, FOH Rack, or Pro Tools playback options. FX Returns are always stereo, and appear on the input channel strips on the Main Unit only.

FX Returns are displayed in banks of 8 on the Main Unit input channel strips.

Up to 16 stereo FX Returns are available, depending on how the system inputs are configured.

Configuring Input Channels

Depending on the number of Mix Engines installed in the system, D-Show can be configured to have 32, 48, 64, or 96 available Input Channels. (This number represents mono channels; each stereo channel uses two mono channels.)

⚠ *Audio may be interrupted or may change levels during this configuration procedure.*

To set the number of available Input Channels:

- 1 Put D-Show into Config mode.
- 2 Go to the Options page and click the System Config tab.

- 3 Click Edit.

- 4 Choose the number of Input Channels from the Channels pop-up menu.

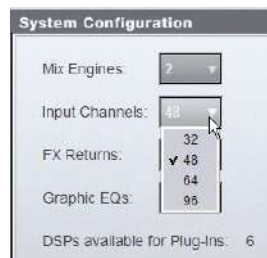

Setting the number of Input Channels

- 5 Click Apply. D-Show restarts with the new Input Channel configuration.

Configuring FX Returns

Depending on the number of Mix Engines installed in the system, you can set D-Show to have either 8 or 16 available FX Returns. FX Returns are always stereo channels.

⚠ *Audio may be interrupted or may change levels during this configuration procedure.*

To set the number of available FX Returns:

- 1 Put D-Show into Config mode.
- 2 Go to the Options page and click the System Config tab.
- 3 Click Edit.
- 4 Choose the number of FX Return channels from the FX Returns pop-up menu.



Setting the number of FX Returns

- 5 Click Apply. D-Show restarts with the new FX Return configuration.

Combining Input Channels (Make Stereo)

Pairs of mono Input Channels can be combined to make stereo channels, whose left and right sides are then controlled by one input channel strip.

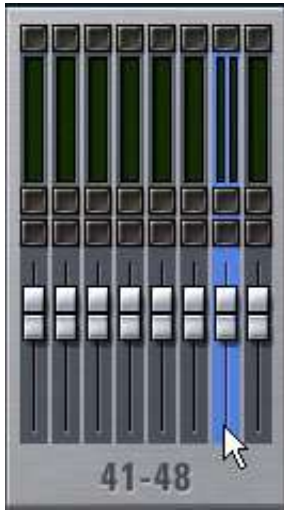

Stereo Input Channel in the Inputs page

Combined Input Channels are shown in the patchbay as left and right sides of the Input Channel name. FX Returns are always stereo, so they cannot be combined or split.



Stereo Input Channel in the Patchbay Input page

To combine pairs of mono input channels and make them stereo:

- 1 Put D-Show into Config mode.
- 2 Press the Make Stereo switch in the Fader Control section. The Make Stereo switch flashes when this function is active.
- 3 Press the Select switches on the mono channel pairs you want to combine. The channels do not need to be contiguous.
- 4 Press the flashing Make Stereo switch to confirm the operation.

Each selected channel is combined with the next-highest selected channel, even if the selected channels are not contiguous. Channel order on the control surface is rearranged to accommodate the new stereo channels. All parameter values from the leftmost channel of each pair are applied to both channels.

The Stereo LED (just below the Input Level meter) lights to indicate that a channel is a stereo channel.

To split stereo channels and make them mono:

- 1 Put D-Show into Config mode.
- 2 Press the Make Stereo switch so that it flashes.
- 3 Press the Select switches on the stereo channels you want to split into mono channels.
- 4 Press the flashing Make Stereo switch to confirm the operation.

Each selected stereo channel is split, placing the channels next to each other on the control surface and in the Patchbay. Channel order on the control surface is rearranged to accommodate the new mono channels.

Naming Channels

Input Channel and FX Return channel names can be changed from the Inputs page or from the Patchbay.

To change the name of an Input Channel or FX Return channel:

- 1 Go to the Inputs page or the Patchbay page.
- 2 Target the channel whose name you want to change by pressing its Select switch or selecting it on-screen.
- 3 Double-click the channel name.



Changing the name of an Input Channel in the Inputs page

- 4 Type a new name and press Enter on the computer keyboard.



When naming channels in the Patchbay, press Tab on the keyboard to go to the next channel and Shift+Tab to go to the previous channel.

Assigning Inputs to Channels

Available input sources for Input Channels or FX Returns include:

- Stage Rack inputs
- FOH Rack inputs
- Pro Tools playback option outputs
- Plug-In outputs

Assigning Inputs from the Patchbay

Inputs from the Stage Rack, FOH Rack and any Pro Tools playback options are routed to Input Channels or FX Returns from the Patchbay.

To assign an input source to an Input Channel or FX Return from the Patchbay:

- 1 Go to the Patchbay page and click the Inputs tab.
- 2 To the left of the channel grid, click the Channels tab or the FX Returns tab.
- 3 Click in the channel grid to assign an input source (listed across the top) to an Input Channel or FX Return (listed on the left).



Assigning an input source in the Patchbay Inputs page

The Patchbay Inputs page shows the name of the input source and its destination. The input source is also displayed below the channel name in the Inputs page and Patchbay Inputs page.



Input source and destination in the Patchbay Inputs page

A single input source may be assigned to multiple Input Channels or FX Returns (you can split or fan out the source to multiple channels). If a Stage Rack input is assigned to multiple channels, gain control, phantom power and pad settings are linked across those channels.

Each Input Channel or FX Return may be fed by only one input source (multiple sources cannot be routed to a single channel).

Assigning Inputs from Bus-Fed Plug-Ins

Inputs from bus-fed plug-ins are routed to Input Channels and FX Returns from the Plug-In Rack. For more information on routing signals to plug-ins, see “Using Plug-Ins as a Bus Processors” on page 154.

Routing Channels To Busses

Signal from Input Channels and FX Returns can be routed to any of the following output busses: Mains, Groups, and Auxes.

Routing Channels to the Main Busses

The Main busses can be configured to operate as L-R plus Mono (Left-Right stereo plus a Mono channel), or as L-C-R (Left-Center-Right). See “Configuring the Main Busses” on page 70.

You can route signals from an Input Channel or FX Return to either or both of the Main busses simultaneously.

To route a single channel to the Main busses:

- 1 Target the channel by pressing its Select switch.
- 2 In the ACS Bus Assigns section, press the L-R (left and right) or C/Mono (center/mono) switch so that it is lit.

The L-R or C/M Bus Assign LEDs on the channel light to indicate that the channel is routed to the corresponding bus.

To route multiple channels to the Main busses:

- 1 Target the first channel you want to route to the Main busses by pressing its Select switch.
- 2 Press the Multi-Assign switch in the ACS Bus Assigns section.
- 3 Press the Select switches on the other channels you want to route to the Main busses.
- 4 In the ACS Bus Assigns section, press the L-R (left and right) or C/Mono (center/mono) switch so that it is lit.
- 5 Press the flashing Multi-Assign switch to confirm the assignment, or press the Cancel switch to cancel the assignment.

The L-R or C/M Bus Assign LEDs on each channel light to indicate that they are routed to the corresponding bus.

Routing Channels to Groups

D-Show has 8 Group busses that can be configured to be mono or stereo as part of the overall Aux/Group bus configuration. For more information on configuring Group busses, see “Configuring Aux, Group, and Variable Group Busses” on page 70.

You can route signals from an Input Channel or FX Return to any number of Group busses simultaneously. For more information on routing signals to Group busses, see “Group Bus Signal Flow Options” on page 80.

Routing Channels to Auxes

D-Show can be configured to have 8 or 16 available Aux busses as part of the overall Aux/Group bus configuration. Aux busses are always mono, but can be linked in pairs to function in stereo. For more information on linking Aux busses, see “Configuring Aux Busses and Variable Group Busses” on page 83.

You can send input signals from any Input Channel or FX Return to any number of Aux busses simultaneously. For more information on routing signals to Aux busses, see “Aux Bus and Variable Group Bus Signal Flow Options” on page 88.

Routing Inputs to Direct Outputs

All Input Channels and FX Returns have Direct Output capability. Direct Outputs from Input and FX Return channels can be routed to hardware outputs, other busses, and used as inputs to bus-fed plug-ins. For more information on Direct Outputs, see “Direct Outputs” on page 76.

Using Built-In Dynamics and EQ

Each Input Channel has built-in Dynamics processors, a High-Pass Filter and a 4-band EQ; each FX Return has a built-in 2-band EQ. If the channel is a stereo channel, the processor controls are linked and apply to both the left and right sides of the channel.

Using Dynamics on Channels

A built-in Compressor/Limiter and Expander/Gate are available on each Input Channel. Modular controls for all of the built-in dynamics processors are in the ACS Dynamics section, and an input/output curve appears on-screen.

 See Chapter 16, “Dynamics.”

Compressor/Limiter

To use the built-in Compressor/Limiter on a channel, do one of the following:

- Press the Comp In switch on the channel.
 - or –
- Target the channel by pressing its Select switch, then press the Comp/Lim In switch in the ACS Dynamics section.

To adjust the Compressor/Limiter threshold from a channel:

- 1 In the Encoder Assignment section, press the Comp Thrsh switch to assign Compressor/Limiter threshold control to the top row of rotary encoders.
- 2 Turn the assigned rotary encoder to set the Compressor/Limiter threshold value.

To adjust Compressor/Limiter controls from the ACS:

- Press the Select switch next to the Comp/Lim In switch and meter in the ACS Dynamics section. The switch lights to indicate control of the Compressor/Limiter.

Expander/Gate

To use the built-in Expander/Gate on a channel, do one of the following:

- Press the Gate In switch on the channel.
 - or –
- Target the channel by pressing its Select switch, then press the Exp/Gate In switch in the ACS Dynamics section.

To adjust the Expander/Gate threshold from a channel:

- 1 In the Encoder Assignment section, press the Gate Thrsh switch to assign Expander/Gate threshold control to the top row of rotary encoders.
- 2 Turn the assigned rotary encoder to set the Expander/Gate threshold value.

To adjust Expander/Gate controls from the ACS:

- Press the Select switch next to the Exp/Gate In switch and meter in the ACS Dynamics section. The switch lights to indicate control of the Expander/Gate.

Using EQ on Channels

A built-in High-Pass Filter and 4-band EQ are available on each Input Channel and a 2-band EQ is available on each FX Return. Modular controls for all of the built-in EQ processors are in the ACS EQ section, and an EQ response curve appears on-screen.

One of two EQ types can be selected for the built-in EQ, on a per-channel basis: a full-spectrum parametric digital EQ or an analog-modeled EQ.

📖 See Chapter 17, “EQ.”

To use the built-in EQ on a channel, do one of the following:

- Press the EQ In switch on the channel.
 - or –
- Target the channel by pressing its Select switch, then press the EQ In switch at the bottom of the ACS Equalizer section.

Using Inserts on Channels

You can use software plug-in inserts or hardware inserts on any Input Channel or FX Return.

Using Plug-In Inserts on Channels

Plug-Ins are arranged in virtual racks, which allow signals to be sent to and from each plug-in as if it were an external processor. Plug-Ins can be used in two ways: as inserts, or as effects in a Send/Return arrangement.

Insert The plug-in is patched in at the insert point on an Input Channel or FX Return. Each Input Channel may have up to four plug-in inserts.

Send/Return Signal is sent to the plug-in over any of the system busses (usually an Aux Send) and routed back to an Input Channel or FX Return.

For more information on using plug-ins in a Send/Return arrangement, see “Using Plug-Ins as a Bus Processors” on page 154.

Inserting Plug-Ins on Channels

You can insert plug-ins on Input Channels and FX Returns directly from the Inputs page or from the Plug-In Rack.

📖 See Chapter 19, “Plug-Ins.”

To insert a plug-in on a channel:

- 1 Go to the Inputs page and target the channel where you want to insert the plug-in.
- 2 In the Inserts section of the Inputs page, do one of the following:
 - Click one of the four Plug-In Insert pop-up menus and choose a plug-in directly from one of the Plug-In Rack submenus.
 - or –
 - Click one of the four Plug-In Insert buttons to go to the Plug-In Rack, and route the signal to the plug-in using Plug-In Rack controls.



Assigning a plug-in insert in the Inputs page

The name of the plug-in insert appears in the on-screen Plug-In Insert display.

Using Hardware Inserts on Channels

D-Show lets you insert external processors in the signal chain of Input Channels and FX Returns.

Assigning Hardware Inserts to Inputs

You can assign hardware inserts to Input Channels and FX Returns directly from the Inputs page or from the Patchbay.

To assign a hardware insert to an input:

- 1 Go to the Inputs page and target the channel where you want to assign the hardware insert.
- 2 In the Inserts section of the Inputs page, do one of the following:
 - Click the Hardware Insert pop-up menu and choose an insert destination directly from the menu.
 - or –
 - Click the Hardware Insert button to go to the Inserts page of the Patchbay, and assign the insert from the Patchbay.



Assigning a hardware insert in the Inputs page

The name of the hardware insert destination appears in the on-screen Hardware Insert button.

Setting the Hardware Insert Location

You can choose the location of the hardware insert in the signal path, relative to the four plug-in inserts, for each channel. A hardware insert does not need to be currently assigned to do this.

To set the hardware insert location:

- 1 Go to the Inputs page and target the channel where you want to set the hardware insert location.
- 2 In the Inserts section of the Inputs page, click the hardware insert indicator so that it lights red.

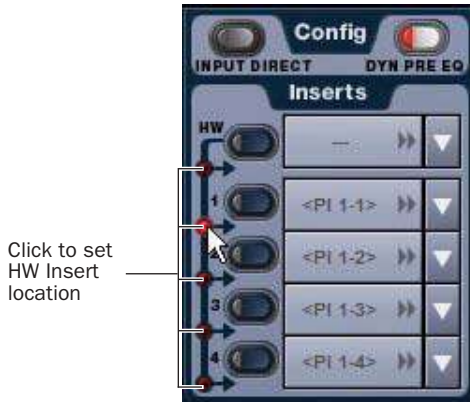

Setting a hardware insert location in the Inputs page

Activating and Bypassing Inserts

After hardware and plug-in inserts are assigned, they can be activated and bypassed from the ACS section or the corresponding Input page controls.

Hardware inserts can also be activated and bypassed directly from Input Channels and FX Returns.

To activate or bypass a channel's plug-in or hardware insert from the ACS section:

- 1 Target the channel by pressing its Select switch.
- 2 Press any of the Plug-In switches or the Hardware switch to activate or bypass the corresponding Insert. The switch lights when the insert is activated.

To activate or bypass a hardware insert from an Input Channel or FX Return:

- Press the Insert In switch on the channel. The switch lights when the insert is in-circuit.

Using Input Direct

Input Direct mode lets you completely bypass the built-in dynamics and EQ processing, and all inserts on Input Channels and FX Returns. This mode routes the input signal directly from the Top of Channel pickoff to the channel fader.

Input Channels Input Direct bypasses the HPF, built-in dynamics and EQ, plug-in inserts, and the hardware insert point on Input Channels.

FX Returns Input Direct bypasses the built-in EQ, plug-in inserts, and the hardware insert point on FX Returns.

To bypass all processing on an input channel:

- 1 Target the channel by pressing its Select switch.
- 2 Press the Input Direct switch in the Channel Config section of the ACS. The switch flashes to indicate Input Direct mode is active on the targeted channel.

Adjusting Input Controls

Input Gain

Input Gain is adjustable from the rotary encoders on each Input Channel and FX Return. Mic inputs have a gain range from +10 dB to +60 dB. Analog line inputs and digital inputs have a gain range from -20 dB to +18 dB.

Gain Guess Feature

An automated Gain Guess function can be used to set a nominal level for a channel based on its incoming signal. When you press and hold the rotary encoder assigned to control gain (either the bottom row of input encoders or the Input Gain encoder in the ACS section), the system samples incoming signals and automatically sets the channel gain and pad for a 0 dB reference when the encoder is released.

Gain Indicators

When Gain is displayed on the lower row of input encoders, the encoder's indicator LED lights to indicate that the gain is set to the default value (+10 dB for analog inputs, and 0 dB for digital inputs). Gain change is indicated by the encoder ring LEDs, and gain value is shown in the channel display.

Setting Input Gain

Gain can be controlled from individual channel strips or from the ACS section.

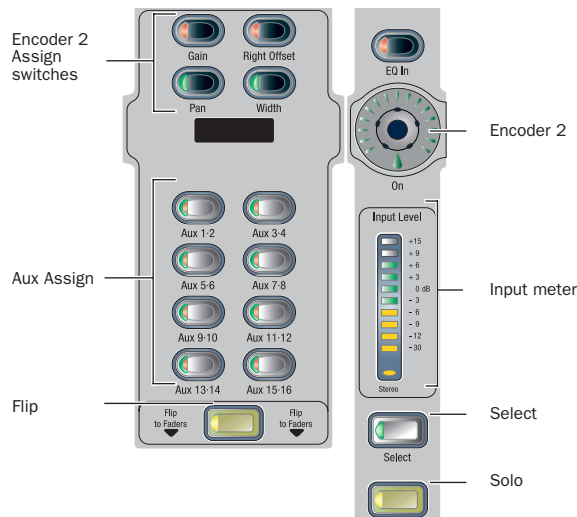

Input controls on input channel strips

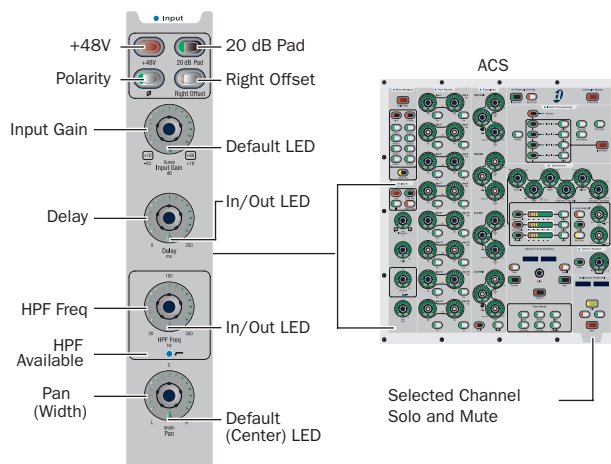

Input controls and their location in the ACS

To adjust input gain for a channel:

- Do one of the following:
 - In the Encoder Assignment section, press the Gain switch to assign gain control to the bottom row of rotary encoders.
 - or –
 - Target the channel by pressing its Select switch. Gain control for the channel is assigned to the Input Gain rotary encoder in the ACS section.
- Adjust the gain by turning the assigned rotary encoder.

To adjust input gain using the Gain Guess feature:

- Press and hold the assigned rotary encoder while the channel is receiving input signal. The LED flashes to indicate level sampling.
- Release the rotary encoder to the current gain guess.

When gain control is assigned to Encoder 2, you can press encoders on multiple channels simultaneously to use Gain Guess on each channel.

Setting Right Offset on Stereo Channels

On stereo Input Channels and FX Returns, the Gain control affects both the left and right channels. The Right Offset feature lets you offset the gain of the right channel relative to the left channel by -20 dB to $+20$ dB, within the overall gain limits.

To adjust channel gain offset for a stereo channel:

- Do one of the following:
 - In the Encoder Assignment section, press the Right Offset switch to assign offset control to the bottom row of rotary encoders.
 - or –
 - Target the channel by pressing its Select switch, then press the Right Offset switch in the ACS Input section. Channel Gain Offset is assigned to the Input Gain rotary encoder in the ACS section.

- Adjust the right channel gain offset by turning the assigned rotary encoder.

Stereo Level Offset Indication

With stereo channels, if the difference in signal level between the left and right channels is 12 dB or greater, the Stereo LED below the channel meter flashes.

Pan

Pan adjusts channel pan (for mono Input Channels) and stereo balance (for stereo Input Channels and FX Returns), allowing you to control panning of signal to Groups or to Mains.

To adjust channel pan/balance:

- Do one of the following:
 - In the Encoder Assignment section, press the Pan switch to assign pan/balance control to the bottom row of rotary encoders.
 - or –
 - Target the channel by pressing its Select switch. Pan/balance control is assigned to the Width/Pan rotary encoder in the ACS section.
- Adjust the channel pan/balance by turning the assigned rotary encoder.

Width

Width adjusts the stereo image of stereo Input Channels and FX Returns by controlling ganged pan positions of the left and right channels, in opposite directions.

Width can be adjusted from full L–R, to mono, to full reversed L–R. Width controls are not available on mono channels.

To adjust width of a stereo channel:

1 Do one of the following:

- In the Encoder Assignment section, press the Width switch to assign width control to the bottom row of rotary encoders.

– or –

- Target the channel by pressing its Select switch. Press the Width/Pan rotary encoder in the ACS section to toggle control of width and pan/balance.

2 Adjust the width by turning the assigned rotary encoder. Turning the encoder clockwise moves the width to full stereo, and counter-clockwise moves the width to reverse stereo. The center position represents mono.

High-Pass Filter

A built-in 4th-order High-Pass Filter can be engaged on each Input Channel. The HPF corner frequency range is from 20 Hz to 500 Hz. The Blue LED below the HPF Freq encoder indicates the HF is available on the corresponding channel.

To engage the built-in HPF on an Insert Channel:

1 Do one of the following:

- In the Encoder Assignment section, press the HPF curve switch to assign HPF control to the top row of rotary encoders.

– or –

- Target the channel by pressing its Select switch. HPF control is assigned to the HPF Freq rotary encoder in the ACS section.

2 Press the assigned rotary encoder to insert the filter in the channel. The rotary encoder “On” indicator LED lights when the HPF is in circuit.

3 Adjust the HPF corner frequency by turning the assigned rotary encoder.

Delay

A variable delay can be applied to any Input Channel or FX Return. The delay range is from 0 to 250 milliseconds.

To apply delay to a channel:

1 Do one of the following:

- In the Encoder Assignment section, press the Delay switch to assign delay control to the top row of rotary encoders.

– or –

- Target the channel by pressing its Select switch. Delay control is assigned to the Delay rotary encoder in the ACS section.

2 Press the assigned rotary encoder to apply the delay to the channel. The rotary encoder “On” indicator LED lights when delay is applied.

3 Adjust the delay value by turning the assigned rotary encoder.

Phantom Power

48V phantom power can be applied to any analog Stage Rack input assigned to an Input Channel or FX Return.

To apply phantom power to a Stage Rack input:

1 Assign a Stage Rack input to a channel. See “Assigning Inputs to Channels” on page 61.

2 Target the channel by pressing its Select switch.

3 Press the +48V switch in the ACS Input section. The switch lights when phantom power is applied to the Stage Rack input. The corresponding channel’s “+48V” LED on the Stage Rack Input Card also lights.



If an input is moved to a different channel, the phantom power setting will move with the input.

20 dB Pad

A 20 dB pad can be applied to any analog Stage Rack input assigned to an Input Channel or FX Return.

To apply a 20 dB pad to a Stage Rack input:

1 Target the channel by pressing its Select switch.

2 Press the 20 dB Pad switch in the ACS Input section. The switch lights when the pad is applied to the Stage Rack input.



The Gain Guess feature may turn the Pad on or off to accommodate incoming signal level

Input Polarity (Phase) Invert

The polarity of any Input Channel or FX Return signal can be inverted. With stereo channels, only the left channel is inverted.

To invert the polarity of a channel:

- 1 Target the channel by pressing its Select switch.
- 2 Press the polarity inversion (\emptyset) switch in the ACS Input section. The switch lights when the polarity is inverted.

Digital Input Sources

On systems that include a DSI (Digital Stage Input) card, the following additional settings and displays are provided.

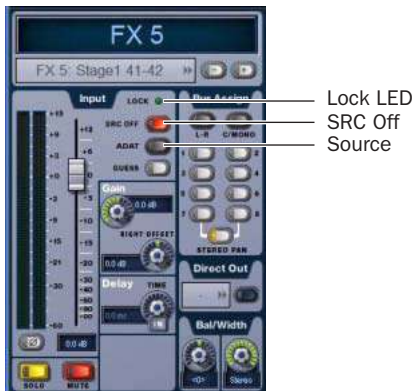

Input controls for a DSI channel

Lock LED Indicates lock status for the channel, and mirrors the same LED on the DSI card.

SRC Off Toggles Sample Rate Conversion on or off for that channel, and mirrors the same LED on the DSI card. A lit SRC Off switch indicates that SRC is disabled.

ADAT (Source) Enables the ADAT Optical port as the active input source on the DSI card. When lit, the DSI card is clocking and listening to corresponding ADAT input; when dark, the channel is receiving input from the corresponding AES input.

Direct Outs are also available on DSI-fed channels, and their pickoff point can be specified in the patchbay.

Channel Solo

Three Solo modes are available: Solo In Place (SIP), Pre-Fader Listen (PFL), and After-Fader Listen (AFL), and several options are available for configuring Solo bus operation. Channels can also be implicitly soloed as part of a VCA.

 See Chapter 14, "Solo and Monitor Busses."

To solo a channel:

- Press the channel's Solo switch so that the Solo switch is lit.

Channel Mute

Channels can be muted in three ways: explicitly with the channel mute switch; implicitly as a result of another channel being soloed, and as a member of a Mute Group or VCA.

 See Chapter 15, "Muting and Mute Groups."

To explicitly mute a channel:

- Press the Mute switch on the channel. The mute switch lights solid to indicate the channel is explicitly muted.

Channel Faders

Channel Faders provide channel level control from $-\infty$ ($-\text{INF}$) to +12 dB.

Fader Banking Controls

Input Channels are displayed in banks on the control surface channel strips. The number of channels in a bank depends on the number of Sidecars in the system.

To bank display of Input Channels on the control surface:

- Press the Bank A, Bank B, Bank C, or Bank D switches to display the corresponding banks of Input Channels.

FX Return Display Controls

The channel strips on the Main Unit can be set to display Input Channels or FX Returns.

FX Returns are always stereo channels.

To display FX Returns on the Main Unit:

- Press the FX Return 1–8 or FX Return 9–16 switch to display the corresponding FX Returns.

Chapter 8: Outputs and Output Routing

Configuring Outputs

Types of Outputs

The following types of output busses are available: Mains, Groups (or Variable Groups), Auxes, Matrixes, and Personal Qs.

In addition, VCA-style control of channel strips is available.

Mains

The Main busses can be configured in L-R+M or L-C-R formats. For more information, see “Configuring the Main Buses” on page 70.

The Main busses are controlled from the dedicated Mains controls and fader in the Output section.

Groups

Eight Group busses are available. These Group busses can be globally configured to be mono or stereo as part of the overall Aux/Group bus configuration. See “Configuring Aux, Group, and Variable Group Buses” on page 70.

Group outputs can be controlled from either the Assignable Output Encoders or Assignable Output Faders in the Output section.

 See Chapter 9, “Groups.”

Auxes

Up to 16 Aux busses are available. The number of available Aux busses is set as part of the overall Aux/Group bus configuration. See “Configuring Aux, Group, and Variable Group Buses” on page 70.

Aux bus outputs can be controlled from either the Assignable Output Encoders or Assignable Output Faders in the Output section.

 For more information, see Chapter 10, “Auxes and Variable Groups.”

Variable Groups

When D-Show is in *Variable Groups mode*, the 8 Group busses operate in much the same way as Aux busses. This bus configuration mode lets you send independently controllable signals to all 24 busses in the system.

When set to Variable Groups mode, the D-Show Output section has 16 available Aux busses and 8 available Variable Group busses.

Variable Groups mode is set as part of the Aux/Group bus configuration. See “Configuring Aux, Group, and Variable Group Buses” on page 70.

Matrixes and Personal Qs

Eight Matrix mixers and 8 Personal Q mixers are available. Matrixes and Personal Qs function independently and can have separate input sources.

Matrix mixer and Personal Q mixer input sources are assigned in the Pickoffs tab of the Options page.

Matrix mixer outputs are mono and Personal Q mixer outputs are stereo.

Matrix mixer outputs and Personal Q mixer outputs can be controlled from the Assignable Output Faders in the Output section.

 See Chapter 11, “Matrix Mixers and PQ Mixers.”

Configuring the Main Busses

The Main busses can be configured to operate in the following ways:

L-R Plus Mono Pans signals between the left and right channels to the L-R bus, and sums signals to a separate mono bus.

L-C-R Pans signals across left, center and right channels.

⚠ *Audio may be interrupted or may change levels during this configuration procedure.*

To configure the Main busses:

- 1 Put D-Show into Config mode.
- 2 Go to the Options page and click the System Config tab.
- 3 Click Edit.



Setting the Main bus configuration

- 4 Select the configuration for the Main Busses.
- 5 Click Apply. D-Show restarts with the new Main bus configuration.

Configuring Aux, Group, and Variable Group Busses

Auxes and Groups (or Variable Groups) share the available system busses. Configuration options include the following:

16 Auxes + 8 Mono Groups Divides the available system busses between 16 mono Aux busses and 8 mono Group busses.

8 Auxes + 8 Stereo Groups Divides the available system busses between 8 mono Aux busses and 8 stereo Group busses.

16 Auxes + 8 Variable Groups (24 Bus) Divides the available system busses between 16 mono Aux busses and 8 mono Variable Group busses (Variable Groups mode).

⚠ *Audio may be interrupted or may change levels during this configuration procedure*

To configure the Aux/Group/Variable Group busses:

- 1 Put D-Show into Config mode.
- 2 Go to the Options page and click the System Config tab.
- 3 Click Edit.
- 4 Select a bus configuration.

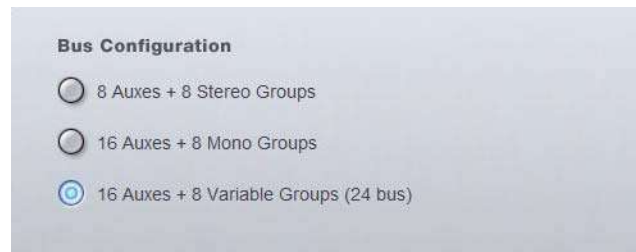

Selecting a bus configuration

- 5 Click Apply. D-Show restarts with the new bus configuration.

Data Cleared When Changing Bus Configurations

When the bus configuration is changed, the following settings are cleared (or set to default) from the current console settings and from all stored snapshots, for all Groups (or Variable Groups):

- Group Bus Output levels
- Group Bus Plug-In routing
- Group Bus Graphic EQ assignments
- Group Bus Direct Output assignments
- Snapshot references to Groups
- Input channel routing to Groups
- Group Pan (mono) and Balance/Width (stereo) settings
- Group assignments to Mains

Linking Aux Busses and Variable Group Busses

When working with Aux busses or Variable Group busses, you can link odd/even bus pairs and pan input signals into those bus pairs. Aux bus pairs and Variable Group bus pairs are linked on a global basis, and appear as linked on all channels.

For more information on linking Auxes and Variable Groups, see “Linking Aux Busses and Variable Group Busses for Stereo Operation” on page 84.

Naming Channels

Output channel names can be changed from the Outputs page or from the Patchbay.

To change the name of an Output channel:

- 1 Go to the Outputs page or the Patchbay page.
- 2 Target the channel whose name you want to change by pressing its Select switch or selecting it on-screen.
- 3 Double-click the channel name.



Changing the name of an Output channel in the Outputs page

- 4 Type a new name and press Enter on the computer keyboard.

💡 When naming channels in the Patchbay, press Tab on the keyboard to go to the next channel and Shift+Tab to go to the previous channel.

Routing Busses to Hardware Outputs

Mains, Groups (or Variable Groups), Auxes, Matrix mixer outputs and PQ mixer outputs can be routed to any hardware output on the system. Available output destinations include:

- Stage Rack outputs
- FOH Rack outputs
- Pro Tools recording option inputs

Busses and mixer outputs are routed to system outputs from the Patchbay.

To assign a bus or mixer output to a system output from the Patchbay:

- 1 Go to the Patchbay page and click the Outputs tab.
- 2 To the left of the channel grid, click the Mains, PQ, Matrix, Aux or Group tab.
- 3 Click in the channel grid to assign a bus or Matrix/PQ mixer output (listed on the left) to a hardware output (listed across the top).



Assigning an output in the Patchbay Outputs page

The Patchbay Outputs page shows the name of the bus or mixer and its destination. The destination is also displayed below the channel name in the Outputs page and Patchbay Outputs page.



Output name and destination in the Patchbay Outputs page

Routing Group Outputs to the Main Busses

You can route Group outputs to the Main busses on-screen or from the ACS.

💡 Variable Groups cannot be routed to the Mains.

To route a Group output to the Main busses on-screen:

- 1 Go to the Outputs page and select the channel fader strip for the Group you want to route to the Main busses.
- 2 Click the Bus Assign buttons on-screen to toggle the bus assignment for the selected Group.



Assigning a Group output to the Main busses from the Output page

To route a Group output to the Main busses from the ACS:

- 1 Press the Groups switch in the Output Fader assignment section to assign control of Group levels to the faders.

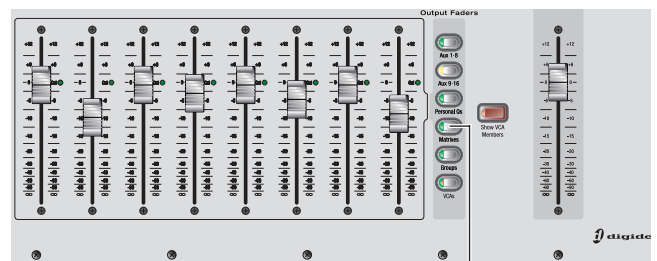

Groups switch

Assigning control of Groups to the Assignable Output Faders

- 2 Select the channel for each Group you want to assign to the Main busses.

3 In the ACS Bus Assigns section, press the L–R (left and right) or C/Mono (center/mono) switch so that it is lit.

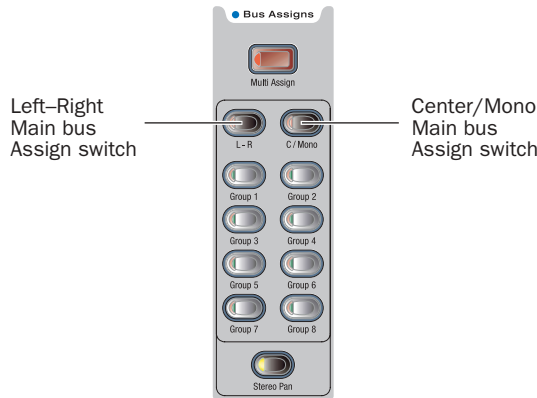

Assigning a Group output to the Main busses from the ACS

4 Move the channel’s fader to set the Group output level.

Group Routing Indication on Assignable Output Encoders

When Groups are assigned to the Assignable Output Encoders, the encoder indicator LEDs indicate Main bus assignments as follows:

Off Group routing to Mains is turned off.

Yellow Group output is routed to the Mains L–R bus.

Green Group output is routed to the Mains C/M bus.

Red Group output is routed to both the Mains L–R bus and the Mains C/M bus.

Using Inserts on Output Busses

You can use software plug-in inserts or hardware inserts on any of the following Output bus types: Mains, Groups (or Variable Groups), Auxes, Matrixes, and Personal Qs.

Using Plug-In Inserts on Output Busses

You can insert plug-ins on Output busses directly from the Outputs page.

See Chapter 19, “Plug-Ins.”

To insert a plug-in on an output bus:

1 Go to the Outputs page and target the bus where you want to insert the plug-in.

2 In the Inserts section of the Outputs page, do one of the following:

- Click one of the four Plug-In Insert pop-up menus and choose a plug-in directly from one of the Plug-In Rack submenus.
- or –
- Click one of the four Plug-In Insert buttons to go to the Plug-In Rack, and route the signal to the plug-in using Plug-In Rack controls.



Assigning a Plug-In Insert in the Outputs page

The name of the plug-in insert appears in the on-screen Plug-In Insert button.

If the output bus is assigned to the Assignable Output Encoders or Assignable Output Faders, the corresponding Insert LED lights to indicate the presence of an insert.

Using Hardware Inserts on Output Busses

D-Show lets you insert external processors in the signal chain of Output busses. Signals from these sources are routed to and from analog or digital I/O connectors on the FOH Rack.

Assigning Hardware Inserts to Outputs

You can assign hardware inserts to Output busses directly from the Outputs page or from the Patchbay.

To assign a hardware insert to a bus:

1 Go to the Outputs page and target the bus where you want to assign the hardware insert.

2 In the Inserts section of the Outputs page, do one of the following:

- Click the Hardware Insert pop-up menu and choose an insert destination directly from the menu.
- or –
- Click the Hardware Insert button to go to the Inserts page of the Patchbay, and assign the insert from the Patchbay.



Assigning a hardware insert in the Outputs page

The name of the hardware insert destination appears in the on-screen Hardware Insert button.

If the output bus is assigned to the Assignable Output Encoders or Assignable Output Faders, the corresponding Insert LED lights to indicate the presence of an insert.

Setting the Hardware Insert Location

You can choose the location of the hardware insert in the signal path, relative to the four plug-in inserts, for each channel. A hardware insert does not need to be currently assigned to do this.

To set the hardware insert location:

- 1 Go to the Outputs page and select the channel where you want to set the hardware insert location.
- 2 In the Inserts section of the Outputs page, click the hardware insert indicator so that it lights red.

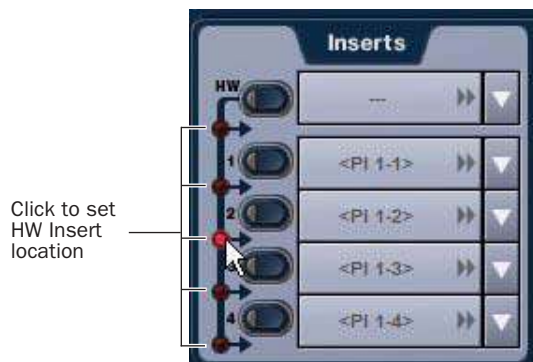

Setting a hardware insert location in the Inputs page

Activating and Bypassing Inserts

After hardware and plug-in inserts are assigned to an Output bus, they can be activated and bypassed from the ACS section or the corresponding Output page controls.

To activate or bypass an Output bus insert:

- 1 Target the bus by pressing its Select switch.
- 2 Press any of the Plug-In switches or the Hardware switch to activate or bypass the corresponding Insert. The switch lights when the Insert is activated.

Inserting the Built-In Graphic EQ on Output Busses

A built-in 31-band Graphic EQ can be inserted on any of the following Output bus types: Mains, Groups (or Variable Groups), Auxes, Matrixes, and PQs. A maximum of 24 Graphic EQs are available, depending on how they are configured in the System Configuration Options.

For more information on configuring and using Graphic EQs, see “Graphic EQ for Outputs” on page 137.

To insert a Graphic EQ on an Output bus:

- 1 Target the bus by pressing its Select switch.
- 2 In the Outputs page, click the Graphic EQ tab.
- 3 Click the Graphic EQ pop-up menu and choose an available mono or stereo Graphic EQ. The entire Graphic EQ is displayed on-screen.



Graphic EQ displayed in the Outputs page

Adjusting Output Controls

Different types of outputs can be controlled independently from the Assignable Output Encoders and Assignable Output Faders.

- The Assignable Output Encoders can be used to control Aux outputs, Group outputs (or Variable Group outputs when in Variable Groups mode), and Matrix and PQ mixer inputs.
- The Assignable Output Faders can be used to control Aux outputs, Group outputs (or Variable Group outputs when in Variable Groups mode), VCAs, and Matrix and PQ mixer outputs.

Output Levels

To control output levels from the Assignable Output Faders:

1 Press one of the following switches in the Output Fader assignment section:

- Aux 1–8
- Aux 9–16
- Personal Qs
- Matrixes
- Groups (assigns Variable Groups when in Variable Groups mode)

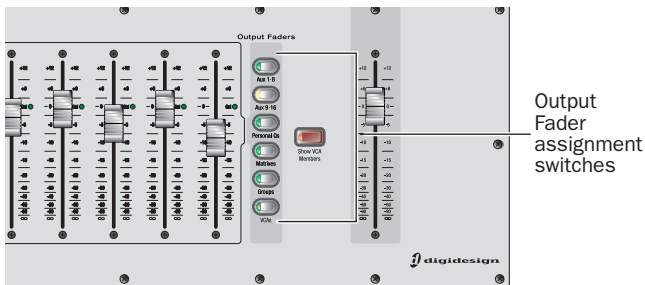

Assignable Output Fader controls

2 Move a fader to change the level of its assigned output.

To create a level offset between linked Aux bus or Variable Group bus output faders:

1 Press one of the following switches in the Output Fader assignment section:

- Aux 1–8
- Aux 9–16
- Groups (when in Variable Groups mode)

2 Do one of the following:

- Touch one linked bus output fader while moving the other.
- Press and hold the F1 switch on the control surface and move one linked Aux bus fader.
- Hold the Start (Win) key on the keyboard and move one linked Aux bus fader on-screen.

The offset between the faders is maintained until the offset causes a fader to reach its maximum or minimum value.

To control Aux or Group output levels from the Assignable Output Encoders:

1 Press one of the following switches in the Output Encoder assignment section:

- Aux 1–8
- Aux 9–16
- Groups (assigns Variable Groups when in Variable Groups mode)

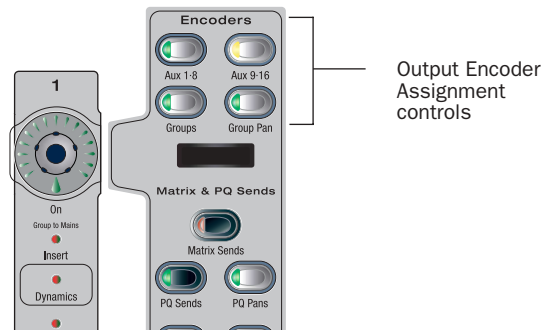

Assignable Output Encoders

2 Turn an encoder to change the level of its assigned output.

Output Polarity (Phase) Invert

The polarity of any output bus signal can be inverted. With stereo outputs (Personal Q outputs and stereo Group busses) only the left channel is inverted.

To invert the polarity of an output bus:

- 1 Target the bus by pressing its Select switch.
- 2 Press the polarity inversion (\emptyset) switch in the ACS Input section. The switch lights when the polarity is inverted.

Output Solo

To control the solo status of an output bus:

1 Press one of the following switches in the Output Fader or Output Encoder assignment sections:

- Aux 1–8
- Aux 9–16
- Personal Qs (Assignable Output Faders only)
- Matrixes (Assignable Output Faders only)
- Groups (assigns Variable Groups when in Variable Groups mode)

2 In the Output section, press an AFL switch to toggle the solo status of the corresponding output bus.

For more information on Solo bus operation, see Chapter 14, "Solo and Monitor Busses."

Output Mute

To control the mute status of an output bus:

1 Press one of the following switches in the Output Fader or Output Encoder assignment sections:

- Aux 1–8
- Aux 9–16
- Personal Qs (Assignable Output Faders only)
- Matrixes (Assignable Output Faders only)
- Groups (assigns Variable Groups when in Variable Groups mode)

2 Press a Mute switch to toggle the mute status of the corresponding output bus.

For more information on Mute operation, see Chapter 15, “Muting and Mute Groups.”

Adjusting Main Bus Controls

Main Bus Output Levels

The Main bus output levels are controlled from the single Mains Fader located on the far right of the D-Show Main Unit.

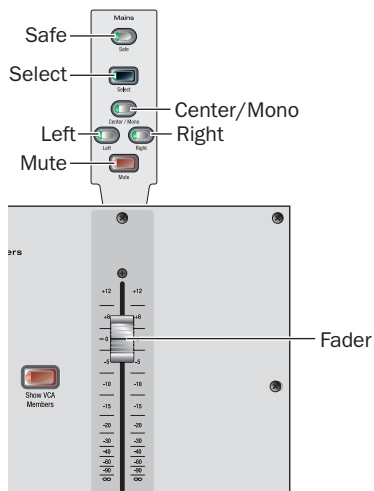

Mains Fader and controls

The Left, Right, and Center/Mono busses can be controlled independently or in tandem.

You can create an offset between any of the Main bus levels, and it will be preserved when controlling any combination of the Main busses. The offset between the busses is maintained until at least one of the busses is zeroed or maxed.

To control the Main bus output levels:

- 1** Press any combination of the Left, Right, or Center/Mono switches to assign control of the corresponding busses to the Mains Fader.
- 2** Move the fader to change the level of the assigned busses.

Main Bus Mute

The mute status of the Main busses is controlled from the Mute switch located above the Mains Fader. When at least one of the Main busses is not muted, the Mains mute switch flashes.

To control the mute status of the Main busses:

- 1** Press any combination of the Left, Right, or Center/Mono switches to assign control of the corresponding busses to the Mains Fader.
- 2** Press the Mute switch to toggle the mute status of the assigned busses.

Main Bus Delay

A variable delay (from 0 to 500 ms) can be applied to any of the Main busses.

To apply delay to a Main bus:

- 1** Target the Main bus where you want to apply delay by repeatedly pressing the Select switch in the Mains section, or by selecting it on-screen.
- 2** Press the ACS Delay rotary encoder to apply the delay to the bus.
- 3** Adjust the delay value by turning the Delay rotary encoder.

Main Bus Center Divergence Options

When the Main busses are set to L–C–R (Left–Center–Right) mode, the Center Divergence setting determines amount of center-panned signal sent to the center output.

- ◆ When Center Divergence is set to 100%, a channel panned to center is sent to the center output only.
- ◆ When Center Divergence is set to 0%, a channel panned to center is sent equally to the left and right outputs only (phantom center).
- ◆ A Center Divergence setting between 0% and 100% sends a center-panned channel to the left, center, and right outputs with the center channel more prominent as the value increases towards 100%.

To set Center Divergence:

- Enter a value or drag in the Center Divergence text box and press Return.

Main Bus Automatic Delay Compensation

D-Show automatically compensates for delays incurred by the use of Groups and insertion of plug-ins in the signal path to the Main busses. Delays are automatically applied to signals arriving at the Main busses from multiple destinations to maintain the proper time alignment.

Monitoring the Main Mix

You can send the Main mix (the signal present on the Main busses) to the Monitor bus for routing to near-field monitors or headphones. See “Sending the Main Mix to the Monitor Bus” on page 113.

Direct Outputs

The following types of channels or busses have Direct Output capability: Input Channels, FX Returns, Main busses, Group (or Variable Group) busses, Aux busses, Matrix busses and PQ busses.

Available destinations for Direct Outputs include:

- Stage Rack outputs
- FOH Rack outputs
- Pro Tools recording option inputs

Each output destination may be fed by only one Direct Output signal (multiple Direct Output signals cannot be routed to a single output).

To route a channel or bus to a Direct Output:

- 1 Target the channel or bus you want to route to a Direct Output by pressing its Select switch.
- 2 In the ACS Direct Output section, press the Assign switch.
- 3 In the Directs page of the Patchbay, click the tab for the channel or bus type you are routing.
- 4 Click in the channel grid to route the channel or bus (listed on the left) to an available output (listed across the top).



Assigning a Direct Output in the Patchbay Directs page

- 5 Select the pickoff point for the Direct Output by clicking the letter to the right of the channel or bus name and choosing from the pop-up menu.

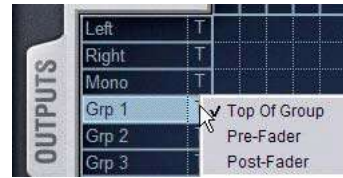

Selecting a Direct Output pickoff point in the Patchbay Directs page

- 6 In the ACS section, press the Direct Output rotary encoder knob so that its “On” indicator LED lights.
- 7 Turn the Direct Output rotary encoder knob to set the Direct Output level.

Up to 12 dB of gain can be added to the Direct Output signal. Direct Output level is displayed in the Options & Snapshots displays.

Direct Output Pickoff Points

The pickoff points for the Direct Output signal are selected in the Directs page of the Patchbay. The following pickoff points that are available for each type of channel or bus:

Input Channels

- Top of channel
- Insert return
- Pre/post fader

FX Returns

- Top of return
- Pre/post fader

Outputs

- Top of bus
- Pre-fader
- Post-fader

Configuring Direct Output Pickoff Points

Input Channels and FX Returns can be globally configured to have either a pre-fader or post-fader pickoff point for Direct Outputs. These pickoff points can be pre-mute or post-mute, depending on the channel or bus type.

On Input Channels and FX Returns, channel mute is pre-fader. On Output busses, channel mute is post-fader.

To configure the Direct Output pickoff point for Inputs:

- 1 Go to the Options page and click the Pickoffs tab.
- 2 Under “Input Strip Fader Pickoff Point,” click Pre-Fader or Post-Fader.

Matrix Mixers

Eight Matrix mixers are available for sending up to eight mono mixes of output channels to any hardware output on the system. Each Matrix is a 12 x 1 mixer with the following sources: 8 Group busses or Aux busses (selectable in the Pickoffs tab of the Options page), the 3 Main busses (L–C–R or L–R+M) and one user-selectable channel.

Matrix input levels are controlled from the Assignable Output Encoders. The master output of each Matrix mixer is controlled from the Assignable Output Faders. Adjacent Matrix inputs can be linked or unlinked.

 See Chapter 11, “Matrix Mixers and PQ Mixers.”

Personal Q Mixers

Eight Personal Q (PQ) mixers are available for sending up to eight discrete stereo mixes of output channels to any hardware output on the system. Each PQ is a 12 x 2 mixer with the following sources: 8 Group busses or Aux busses (selectable in the Pickoffs tab of the Options page), the 3 Main busses (L–C–R or L–R+M) and one user-selectable channel.

Each of these PQ mixers are remotely controllable by optional PQ Controller units, which allow adjustment of PQ mixer levels from the stage.

 *If no PQ Controllers are used, the PQ mixers are still available for use as stereo Matrix mixers at the console.*

PQ input levels and PQ input pan are controlled from the Assignable Output Encoders. The master output of each PQ mixer is controlled from the Assignable Output Faders. Adjacent PQ inputs can be linked or unlinked.

 See Chapter 11, “Matrix Mixers and PQ Mixers.”

Assigning and Using VCAs

D-Show VCA controls emulate the operation of VCA (Voltage Controlled Amplifier) groups. Up to eight VCA faders are available for remote control of Input Channel and FX Return, or Output channel fader gain.

 *VCAs control level of the assigned channels only. They do not act as a summing output bus.*

VCAs directly control the fader gain of each channel assigned to the VCA fader, but do not change the position of the faders on those channels. The accumulated gain of a channel belonging to several VCAs is limited to +12 dB.

To assign channels to VCAs:

- 1 Press the VCAs switch in the Assignable Output Faders section.
- 2 Press the Multi-Assign switch above the Assignable Output Fader for the VCA you want to use.
- 3 Press the Select switches on the Input Channels, FX Returns, or Output channels you want to assign to the VCA.
- 4 Press the flashing Multi-Assign switch to confirm the assignment, or press the Cancel switch to cancel the assignment.

Viewing Members of a VCA

To view the members of a VCA:

- Go to the Outputs page and select a VCA channel. A list of VCA members appears on the right side of the screen.

To view which Input Channels are members of a VCA:

- Press the Show Members switch to the right of the Assignable Output Faders section. The Bus Assign LEDs 1–8 at the top of each channel flash to indicate which Input Channels are members of the VCA.

Using VCAs

To adjust the levels of VCA members:

- 1 Press the VCAs switch, located to the right of the Assignable Output Faders section, to assign control of the VCAs to the faders.
- 2 Move the fader for the VCA whose members you want to adjust.

To solo the members of a VCA:

- Press the Solo switch on the VCA channels whose members you want to solo so that the Solo switch is lit.

To mute the members of a VCA:

- Press the Mute switch on the VCA channels whose members you want to mute. The Mute LEDs on channels contained in the VCA flash to indicate they are implicitly muted by the VCA.

Chapter 9: Groups

The D-Show Output section has 8 available Group busses. Groups busses can be fed by Input Channels and FX Returns. Group outputs can be assigned to the Main Output busses and to any hardware outputs on the system. Group outputs can also be the source for Matrix and PQ mixers.

Configuring Group Busses

Group busses can be globally configured to be mono or stereo as part of the Aux/Group bus configuration. See “Configuring Aux, Group, and Variable Group Busses” on page 70.

Assigning Inputs to Group Busses

You can route signals from an Input Channel or FX Return to any number of Group busses simultaneously.

To route multiple channels to a single Group bus:

- 1 Press the Groups switch in the Assignable Output Fader assignment section to assign control of Groups to the faders.
- 2 Press the Multi-Assign switch on the Output Fader strip for the Group where you want to route the channels.
- 3 Press the Select switches on the channels you want to route to the Group. You can also deselect channels to remove them from the Group.
- 4 Press the flashing Multi-Assign switch to confirm the assignment, or press the Cancel switch to cancel the assignment.

To route a single channel to any number of Group busses:

- 1 Select the channel you want to route to a Group bus by pressing its Select switch.
- 2 In the ACS Bus Assigns section, press any of the Group switches to route the channel to the corresponding Group busses.

To route multiple channels to any number of Group busses:

- 1 Target the first channel you want to route to the Group busses by pressing its Select switch.
- 2 Press the Multi-Assign switch in the ACS Bus Assigns section.

3 Press the Select switches on the other channels you want to route to a Group bus.

4 In the ACS Bus Assigns section, press any of the Group switches so that they are lit.

5 Press the flashing Multi-Assign switch to confirm the assignment, or press the Cancel switch to cancel the assignment.

Managing Group Bus Assignments

Viewing Group Bus Assignments

You can view Group bus assignments from the Input section of the control surface or from an on-screen list of Group members.

Viewing Group Bus Assignments from the Input Section

The Bus Assign LEDs 1–8 on Input Channels and FX Return channel strips light to indicate that a channel is routed to the corresponding Group busses. The Stereo Pan LED lights when at least one bus is being fed as a stereo-linked pair or in true stereo.

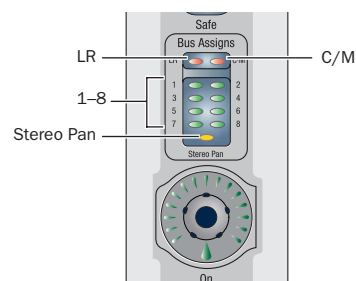

Bus Assign Indicators on an Input Channel

Viewing Group Bus Assignments On-Screen

When a Group bus channel is targeted on-screen, its members are shown in a list on the right side of the Outputs page.



Group members shown in the Outputs page

Resetting Group Bus Assignments

You can remove input assignments from a Group bus on-screen.

To remove an input assignment from a Group bus:

- 1 Select the Group bus you want to change so that its members are displayed on-screen.
- 2 In the list of Group bus members, right-click the input assignment you want to remove and choose Unassign.

To remove all input assignments from a Group bus:

- 1 Select the Group bus you want to change so that its members are displayed on-screen.
- 2 Click the pop-up menu at the bottom of the Members list and choose Reset Mix.

Group Bus Signal Flow Options

Routing Signals to a Mono Group Bus Configuration

When configured as mono busses, the eight Groups can be fed as 8 unlinked mono busses or up to 4 linked odd/even bus pairs.

Unlinked Mono Busses

To use unlinked mono Group busses:

- 1 Make sure the Group busses are configured as mono busses. See “Configuring Aux, Group, and Variable Group Busses” on page 70.
- 2 While routing channels to Group busses, make sure the Stereo Pan switch is off.

The Group switches in the ACS Bus Assigns section light green to indicate mono operation. In this configuration, input signals are handled as follows:

Mono Input Signals Contributing mono signals are summed to the mono Group bus. Any pan information from mono input channels feeding the bus is ignored.

Stereo Input Signals Contributing stereo signals are summed to the mono Group bus with no attenuation. The balance and width information from each stereo input channel is ignored.

Linked Odd/Even Bus Pairs

To use linked mono Group bus pairs:

- 1 Make sure the Group busses are configured as mono busses. See “Configuring Aux, Group, and Variable Group Busses” on page 70.
- 2 While routing channels to Group busses, press the Stereo Pan switch so that it lights yellow.

The Group switches in the ACS Bus Assigns section and the Stereo Pan LED in the channel’s Bus Assign indicator light yellow to indicate stereo operation. In this configuration, input signals are handled as follows:

Mono Input Signals Contributing mono signals are panned across the linked odd/even Group bus pair. Pan information from each mono input channel determines its pan position in the bus pair.

Stereo Input Signals Contributing stereo signals are panned across the linked odd/even Group bus pair. Balance and width information from each stereo input channel determines its contribution to the odd and even sides of the bus pair.

Routing Signals to a Stereo Group Bus Configuration

When configured as stereo busses, the eight Groups can be fed as 8 true stereo busses or (in Expert mode only) as 8 dual mono busses.

Stereo Busses

To use stereo Group busses:

- 1 Make sure the Group busses are configured as stereo busses. See “Configuring Aux, Group, and Variable Group Busses” on page 70.
- 2 When routing channels to any of the Group busses, make sure the Stereo Pan switch is lit yellow.

 *When working with stereo Groups in Simple Mode, the Stereo Pan switch is always lit to indicate all Groups operate in true stereo.*

Dual Mono Busses

Dual mono busses may only be used in Expert Mode. See “Simple and Expert Operational Modes” on page 82.

Adjusting Group Bus Output Controls

Group Bus Output Levels

See “Adjusting Output Controls” on page 74.

Group Bus Output Pan

Group bus output pan is controlled from the Assignable Output Encoders. The pan controls adjust pan (when in mono Groups configuration) or stereo balance and width (when in stereo Groups configuration) of the Group output to the Main busses only. The Group outputs in the Patchbay are distinct left and right channels.

To control mono Group output pan:

- 1 Press the Group Pan switch in the Output Encoder assignment section to assign control of Group pan to the Assignable Output Encoders.
- 2 Turn a rotary encoder to adjust the pan for the corresponding mono Group.

To control stereo Group output balance and width:

- 1 Press the Group Pan switch in the Output Encoder assignment section to assign Group balance control to the Assignable Output Encoders. The Output Encoder scribble strips show “GR BAL.”
- 2 Turn a rotary encoder to adjust the balance for the corresponding stereo Group.
- 3 Press the Group Pan switch in the Output Encoder assignment section a second time to assign Group width control to the Assignable Output Encoders. The Output Encoder displays show “GR WID.”
- 4 Turn a rotary encoder to adjust the width for the corresponding stereo Group.

Group Bus Output Polarity (Phase) Invert

See “Output Polarity (Phase) Invert” on page 74.

Group Bus Output Solo

See “Output Solo” on page 74.

Group Bus Output Mute

See “Output Mute” on page 75.

Routing Group Bus Outputs to the Main Busses

See “Routing Group Outputs to the Main Busses” on page 71.

Routing Group Busses to Direct Outputs

Group busses have Direct Output capability. For more information, see “Direct Outputs” on page 76.

Using Inserts on Group Bus Outputs

You can insert D-Show software plug-ins or hardware inserts on Group bus outputs. For more information, see “Using Inserts on Output Busses” on page 72.

Inserting the Built-In Graphic EQ on Group Bus Outputs

A built-in 31-band Graphic EQ can be inserted on Group bus outputs. For more information, see “Inserting the Built-In Graphic EQ on Output Busses” on page 73.

Simple and Expert Operational Modes

When configuring Group busses, you can choose between two operational modes that provide different levels of flexibility: *Simple mode* and *Expert mode*.

Setting the Operational Mode

To switch between Simple mode and Expert mode:

- 1 Put D>Show into Config mode.
- 2 Go to the Options page and click the Busses tab.
- 3 Under Stereo Group Panning Operation, select the mode you want to use (Simple or Expert).



Setting the Group bus operational mode

Working with Mono Group Busses

When configured as mono busses, Groups can operate in the following modes:

Simple Mode

In Simple mode, either all Groups on a channel are mono, or all Groups on a channel act as bus pairs.

Expert Mode

In Expert mode, any of the 4 bus pairs can be stereo linked individually while leaving the other busses as mono, on a per channel basis.

To set the link status of individual mono Group busses on a channel (Expert Mode only):

- 1 Make sure Stereo Group Panning is set to Expert Mode.
- 2 Select an Input Channel or FX Return whose signal you want to send to a Group bus. To select multiple channels, use the Multi-Assign switch in the ACS Bus Assigns section.
- 3 In the ACS Bus Assigns section, press the Stereo Pan switch. The switch flashes yellow to indicate bus link mode.
- 4 Press any of the Group switches to link or unlink the bus pairs (1–2, 3–4, 5–6, or 7–8). The Group switch pairs flash yellow to indicate stereo linked, or flash green to indicate mono.
- 5 Press the flashing Stereo Pan switch to confirm the bus link status for the selected channels.

Working with Stereo Group Busses

When configured as stereo busses, Groups can operate in the following modes:

Simple Mode

In Simple Mode, all 8 Group busses function only as true stereo busses.

Expert Mode

In Expert Mode, any of the 8 stereo Group busses can be set to act as true stereo or as dual mono busses, on a per channel basis.

To set the link status of individual stereo Group busses for a channel (Expert Mode only):

- 1 Make sure Stereo Group Panning is set to Expert Mode.
- 2 Select an Input Channel or FX Return whose signal you want to route to a Group bus. To select multiple channels, use the Multi-Assign switch in the ACS Bus Assigns section.
- 3 In the ACS Bus Assigns section, press the Stereo Pan switch. The switch flashes yellow to indicate bus link mode.
- 4 Press any of the Group switches (1–8) to set the corresponding bus to stereo or dual mono. The Group switches flash yellow to indicate stereo, or flash green to indicate dual mono.
- 5 Press the flashing Stereo Pan switch to confirm the bus link status for the selected channels.

To use dual mono Group busses (Expert Mode only):

- 1 Make sure the Group busses are configured as stereo busses. See “Configuring Aux, Group, and Variable Group Busses” on page 70.
- 2 Make sure the link status of the Group busses you want to use is set to dual mono.

When routing channels to a dual mono Group bus, the Stereo Pan switch will be off and the Group switch will light green to indicate dual mono operation.

Chapter 10: Auxes and Variable Groups

The D-Show Output section has up to 16 available Aux busses, and when set to Variable Groups mode, the 8 Group busses are replaced by *Variable Group* busses. Aux busses and Variable Group busses can be fed by Input Channels and FX Returns, which are routed to Auxes from the Input section.

Configuring Aux Busses and Variable Group Busses

Aux Busses

Up to 16 Aux busses are available. The number of available Aux busses is set as part of the overall Aux/Group bus configuration. See “Configuring Aux, Group, and Variable Group Busses” on page 70.

Variable Group Busses

Variable Groups mode replaces the 8 Group busses with *Variable Group* busses, which operate in much the same way as Aux busses. When set to Variable Groups mode, the D-Show Output section has 16 available Aux busses and 8 available Variable Group busses.

Variable Groups mode is set as part of the Aux/Group bus configuration. See “Configuring Aux, Group, and Variable Group Busses” on page 70.

Labeling of Variable Groups

Variable Groups retain the “Groups” label in the D-Show Patchbay page, in the Options > Pickoffs page, and in the rotary encoder displays on the D-Show control surface.

Variable Groups are labeled as “Var Groups” in the D-Show Inputs page.

Displaying Variable Group Controls

When D-Show is in Variable Group mode, Variable Group controls are displayed in the following locations:

On-Screen Variable Group Send controls replace the Aux Send controls.

On the Control Surface Variable Group Sends are displayed on the ACS controls for Aux Sends 1–8. (ACS controls for Aux Sends 9–16 are unused in this display mode.) Variable Group controls also replace Aux controls in the Input Channel Encoder rows and Encoder assignment controls.

To display Variable Group controls from on-screen:

- 1 Go to the Inputs page and target a channel by selecting its on-screen channel fader strip. Select multiple strips by Shift-clicking.
- 2 Click the Var Groups button in the Bus Assign section. The Var Groups button flashes to indicate display of Variable Group controls.



Variable Group controls displayed in the Inputs page

To display Variable Group controls from the control surface:

1 Target an Input Channel or FX Return by pressing its Select switch.

2 Do one of the following:

- Press the Stereo Pan switch in the ACS Bus Assigns section.
- Press the F2 switch in the Function section.

The Stereo Pan and F2 switches flash to indicate display of Variable Group controls.

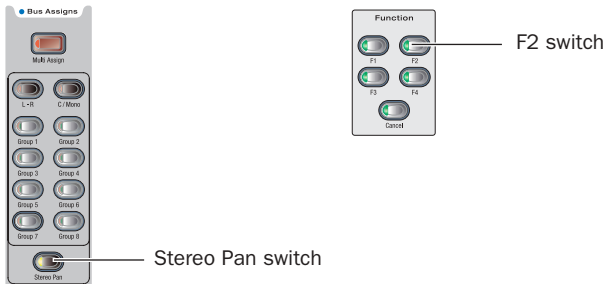

Control surface switches for displaying Variable Groups

To change display back to Aux Sends, do one of the following:

- Click the flashing Var Groups button on-screen.
- or –
- Press the flashing Stereo Pan switch or F2 switch on the control surface.

Linking Aux Busses and Variable Group Busses for Stereo Operation

When working with Aux busses or Variable Group busses, you can link odd/even bus pairs and pan input signals into those bus pairs. Aux bus pairs and Variable Group bus pairs are linked on a global basis, and appear as linked on all channels.

To link Aux bus pairs or Variable Group bus pairs:

- 1 Put D-Show into Config mode.
- 2 Go to the Options page and click the Busses tab.



Linking bus pairs in the Options > Busses page

3 Click Edit.

4 Click the checkboxes above any of the bus pairs to link or unlink each pair.



Linking a Variable Group bus pair

5 Click Apply.

The checked Aux bus or Variable Group bus pairs appear as linked on all channels.

When an Aux bus pair or Variable Group bus pair is linked, the corresponding Stereo LED (marked "St") lights in the ACS Aux Sends section.

With linked Aux bus or Variable Group bus pairs, the following controls operate in tandem, affecting both sides of the bus pair:

- Output faders
- Solo switches
- Mute switches
- Direct Output controls
- Delay Controls (Aux bus pairs only)
- Graphic EQ controls

Selecting Aux Send and Variable Group Send Pickoff Points

D-Show lets you set the pickoff point on Input Channels or FX Returns channels for Aux Sends and Variable Group Sends. The default pickoff point is Post-Fader, but can be switched to any of the following with the Aux Pre switches in the ACS Aux Sends section: Pre-EQ, Pre-Mute, Pre-Fader.

Pre Pickoff points are set for each Aux bus or Variable Group bus independently. If any Aux busses or Variable Group busses are linked, the pickoff point is set for the linked bus pair.

The following Pre pickoff points are available for activation with the Aux Pre switch on the control surface:

Pre-EQ This pickoff point is post-HPF and pre-EQ, Dynamics and Channel Inserts, pre-Mute, and pre-Fader. The Aux or Variable Group Send is not affected by the channel mute.

Pre-Mute This pickoff point is post-HPF, post-EQ, Dynamics, and Channel Inserts, pre-Mute, and pre-Fader. The Aux or Variable Group Send is not affected by the channel mute.

Pre-Fader This pickoff point is post-HPF, post-EQ Dynamics, and Channel Inserts, post-Mute, and pre-Fader. The Aux or Variable Group Send is affected by the channel mute.

To set the Pre pickoff point for an Aux or Variable Group Send:

- 1 Go to the Options page and click the Busses tab.



Setting Aux bus pickoff points

- 2 Select a Pre pickoff point for any of the busses or linked bus pairs by clicking the Pre-EQ, Pre-Mute, or Pre-Fader button.

To activate a Pre pickoff point for an Aux Send or Variable Group Send on-screen:

- 1 Go to the Inputs page and target the channel with the pickoff point you want to activate by clicking its on-screen channel fader strip.
- 2 Do any of the following:
 - To activate an Aux Send Pre pickoff, click the corresponding Pre button in the Aux Sends section.
 - or –
 - To activate a Variable Group Pre pickoff, click the Var Groups button in the Bus Assign section to display Var Groups, and click the corresponding Pre button in the Var Groups section.

When the Pre button is lit, the selected Pre pickoff point is used. When the Pre button is off, the pickoff point is Post-Fader.

To activate a Pre pickoff point for an Aux Send from the control surface:

- 1 Target the channel with the Aux Send pickoff point you want to activate by pressing its Select switch.
- 2 In the ACS section, press the Pre switch for the Aux Send.

When the Pre switch is lit, the selected Pre pickoff point is used. When the Pre switch is off, the pickoff point is Post-Fader.

To activate a Pre pickoff point for a Variable Group Send from the control surface:

- 1 Target the channel with the Variable Group Send pickoff point you want to activate by pressing its Select switch.
- 2 Press the Stereo Pan switch in the ACS Bus Assigns section. Variable Groups 1–8 are displayed on the controls for Aux Sends 1–8 in the ACS.
- 3 In the ACS Aux Sends section, press the Pre switch for the corresponding Variable Group Send. When the Pre switch is lit, the selected pickoff point is used. When the Pre switch is off, the pickoff point is Post-Fader.
- 4 Press the flashing Stereo Pan switch to return the ACS controls to Aux Sends display.

Classifying Auxes and Variable Groups for Snapshots

You can classify Aux Sends and Variable Group Sends as *monitor sends* (“Mon”) or as *effects sends* (“FX”) for the purposes of scoping each type separately in snapshots. See “Classifying Auxes and Variable Groups” on page 188.

Assigning Inputs to Aux Busses and Variable Group Busses

You can send signals from any Input Channel or FX Return to any number of Aux busses or Variable Groups simultaneously. Aux Send and Variable Group Send level controls provide a gain range of $-INF$ to $+12$ dB.

To route channels to any number of Aux busses or Variable Groups from the ACS section:

- 1 Do one of the following to select input channels:
 - Target the channel you want to send to an Aux bus by pressing its Select switch.
 - or –
 - Hold the Multi Select switch in the Input Channel Fader Control section and press the Select switches on each of the channels you want to send to an Aux bus.
- 2 Do one of the following to assign sends for the selected channels:
 - To assign the channel to an Aux bus, press an Aux Send rotary encoder knob in the ACS section.
 - To assign the channel to a Variable Group, press the Stereo Pan switch in the ACS Bus Assigns section, and press an Aux Send rotary encoder knob in the ACS section.

When an Aux Send or Variable Groups Send is active, the encoder's "On" indicator LED lights, and send level is shown by an expanding series of LEDs.

When an Aux Send or Variable Group Send is inactive, send level is shown by a single LED.

- 3 Turn the Aux Send rotary encoder knob in the ACS to set the send level.

Managing Aux Bus and Variable Group Bus Assignments

Viewing Aux Bus and Variable Group Bus Assignments

When an Aux bus or Variable Group bus output channel is targeted on-screen, its members are shown in a list on the right side of the Outputs page.

To view input assignments to an Aux bus or Variable Group bus:

- 1 Go to the Outputs page.
- 2 Target an Aux bus or Variable Group bus output channel by selecting its on-screen channel fader strip. Variable Group channels are labeled "Groups" in the channel display.

Input channels routed to the selected bus are displayed in the Members list on the right side of the page.

To go to any assigned input channel from the Outputs page:

- Click the name of the input channel in the Members list.



Aux bus assignments shown in the Outputs page

Resetting Aux Bus and Variable Group Bus Assignments

You can remove input assignments from Aux bus or Variable Group bus output channels on-screen.

To remove an input assignment from an Aux bus or Variable Group:

- 1 Target the Aux bus or Variable Group bus output channel you want to change by selecting its on-screen channel strip. Variable Group channels are labeled "Groups" in the channel display.
- 2 In the list of member input channel assignments, right-click the input assignment you want to remove and choose Unassign.

To remove all input assignments from an Aux bus or Variable Group bus:

- 1 Target the Aux bus or Variable Group bus output channel you want to change by selecting its on-screen channel strip. Variable Group channels are labeled "Groups" in the channel display.
- 2 Click the pop-up menu at the bottom of the Members list and choose Reset Mix.

Copying Assignments Between Aux Busses and Variable Group Busses

You can copy the current input assignments from one Aux bus or Variable Group bus to another bus of either type. If the busses are linked, assignments can be copied from other linked busses. This lets you quickly duplicate monitor mixes.

⚠ *Copying Aux or Variable Group bus assignments overwrites all the assignments on the destination Aux or Variable Group bus.*

To copy input assignments between Aux/Variable Group busses:

- 1 Target the Aux bus or Variable Group bus that you want to be the destination of the copied assignments by selecting its on-screen channel strip.
- 2 Click the Input Assign pop-up menu at the bottom of the Members list, choose Replace With Mix From, then choose the Aux bus or Variable Group bus whose assignments you want to copy to the currently selected bus.
- 3 Click the Input Assign pop-up menu at the bottom of the Members list, choose Replace With Mix From, then choose the Aux bus or Variable Group bus whose assignments you want to copy to the currently selected bus.

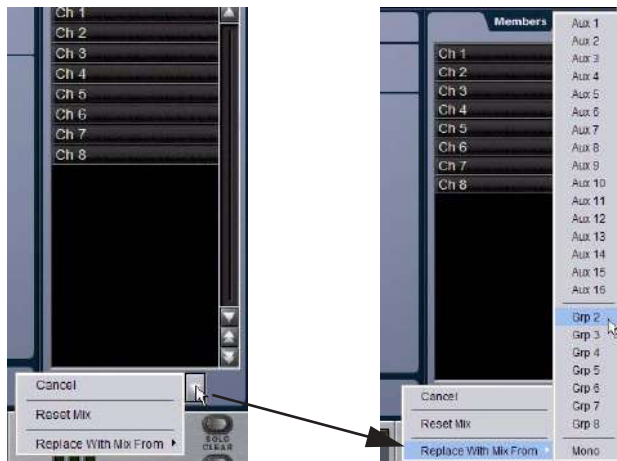

Copying input assignments between Aux busses

Copying Mains Assignments to Aux Busses and Variable Group Busses

You can copy the current Main bus assignments to Aux busses and Variable Group busses, which lets you build monitor mixes from a main mix. Assignments to the Main Left/ Right busses can be copied to linked Aux or Variable Group busses, and assignments to the Center/Mono bus can be copied to mono Aux or Variable Group busses.

To copy bus assignments from the Mains to Auxes or Variable Groups:

- 1 Target the Aux bus or Variable Group bus that you want to be the destination of the copied assignments by selecting its on-screen channel strip.
- 2 Click the Input Assign pop-up menu at the bottom of the Members list, choose Replace With Mix From, then choose the available Main bus (Left-Right or Mono) whose assignments you want to copy to the currently selected bus.

The state of the Aux or Variable Group controls follows the state of the corresponding controls on the Input Channels assigned to the Mains: Channel Mute maps to Bus Send, Channel Pan maps to Bus Pan, and Channel Fader level maps to Bus Send level.

Aux Bus and Variable Group Bus Signal Flow Options

Input channel signals are routed to Aux busses or Variable Group busses (available only in Variable Groups mode) in a similar manner.

Routing Signals to Mono Aux and Variable Group Busses

To route a channel to an unlinked (mono) Aux bus or Variable Group bus from the Input section:

- 1 Do one of the following:
 - Display Aux Sends on the input channels.
 - Display Variable Group Sends on the input channels.
- 2 In either Input Encoder Assignment section, press an Aux switch to assign control of the designated bus to the corresponding row of rotary encoders.
 - The first press of an Aux switch assigns level control of the odd-numbered send. The switch lights green to indicate an odd-numbered selection.
 - The second press of an Aux switch assigns level control of the even-numbered send. The switch lights yellow to indicate an even-numbered selection.
- 3 On each of the channels you want to send to the designated Aux bus or Variable Group bus, press the rotary encoder knob so that its “On” indicator LED lights.
- 4 Turn the rotary encoder knob on each channel to set the Aux Send or Variable Group Send level.

When Aux busses or Variable Group busses are not linked, they are fed as true mono busses. In this configuration, input signals are handled as follows:

Mono Input Signals Contributing mono signals are sent to the mono Aux or Variable Group bus. Any pan information from mono input channels feeding the bus is ignored.

Stereo Input Signals Contributing stereo signals are summed to the mono Aux or Variable Group bus. The balance and width information from each stereo input channel is ignored.

Routing Signals to Linked Aux and Variable Group Bus Pairs

To route a channel to a linked (stereo) Aux bus pair or Variable Group bus pair from the Input section:

- 1 Do one of the following:
 - Display Aux Sends on the input channels.
 - Display Variable Group Sends on the input channels.
- 2 In either Input Encoder Assignment section, press an Aux switch to assign control of the designated bus to the corresponding row of rotary encoders.
 - The first press of an Aux switch assigns level control of the linked sends. The switch lights green to indicate the bus pair is selected.
 - The second press of an Aux switch assigns pan control of the linked sends. The switch lights yellow to indicate pan control.
- 3 On each of the channels you want to send to the designated bus pair, press the rotary encoder knob so that its “On” indicator LED lights.
- 4 Turn the rotary encoder knob on each channel to set the send level or pan.

When Aux busses are linked, input signals are handled as follows:

Mono Input Signals Contributing mono signals are panned across the linked odd/even Aux or Variable Group bus pair.

- When the Follows Channels Pan option is off, panning of the mono signal to the bus pair is controlled by the Aux Pan control.
- When the Follows Channels Pan option is on, the pan information from each mono input channel determines its pan position in the bus pair.

Stereo Input Signals Contributing stereo signals are panned across the linked odd/even Aux or Variable Group bus pair. Stereo width information from the input channel is applied to the bus signal.

- When the Follows Channels Pan option is off, balance of the stereo signal to the bus pair is controlled by the Aux Pan control.
- When the Follows Channels Pan option is on, the balance from each stereo input channel determines its contribution to the odd and even sides of the bus pair.

Controlling Aux Send and Variable Group Send Pan

When Aux busses or Variable Group busses are linked, input signals are panned across the bus pair. Panning can be controlled from the Input section or from the ACS Aux Sends section.

To control panning of Aux bus or Variable Group bus pairs from the Input section:

- 1 Do one of the following:
 - Display Aux Sends on the input channels.
 - Display Variable Group Sends on the input channels.
- 2 In the Input Encoder Assignment section, press the Aux switch for the bus pair you want to pan.
 - The first press of the Aux switch assigns control of the send level to the encoder. The switch lights green and the encoder display shows the odd-numbered send.
 - The second press of the Aux switch assigns control of the send pan to the encoder. The switch lights yellow and the display shows a “P” before the odd-numbered send.
- 3 With the Aux switch lit yellow, turn the rotary encoder knob on each Input Channel or FX Return where you want to adjust the send pan.

To control panning of Aux bus or Variable Group bus pairs from the ACS Aux Sends section:

- 1 Target the channel whose bus pair you want to pan by pressing its Select switch. In a linked bus pair, the ACS Aux Send controls show the following:
 - Odd-numbered rotary encoders control send level
 - Even-numbered rotary encoders control send pan
- 2 Turn the even-numbered rotary encoders in the Aux Sends section to adjust the send pan.

Setting Aux Send Pan and Variable Group Send Pan to Follow Channel Pan

Panning of the input signal can be set to follow the pan or balance values of the Input Channel or FX Return feeding the Aux bus or Variable Group bus.

To set the Aux Send or Variable Group pan to follow Channel pan:

- 1 Go to the Options page and click the Busses tab.
- 2 On any linked bus pairs, select the Follows Channel Pan option. This setting is applied globally to the corresponding Aux Send or Variable Group Send.

Adjusting Aux Bus and Variable Group Bus Output Controls

Aux Bus and Variable Group Bus Output Levels

See “Output Levels” on page 74.

Aux Bus and Variable Group Bus Output Polarity Invert

See “Output Polarity (Phase) Invert” on page 74.

Aux Bus and Variable Group Bus Output Solo

See “Output Solo” on page 74.

Aux Bus and Variable Group Bus Output Mute

See “Output Mute” on page 75.

Aux Bus Output Delay

A variable delay (0–250 ms) can be applied to any of the Aux bus outputs. Variable Group outputs do not have this variable delay feature.

To apply delay to an Aux bus:

- 1 Target the Aux bus by pressing its Select switch.
- 2 Press the ACS Delay rotary encoder to apply the delay to the bus.
- 3 Adjust the delay value by turning the Delay rotary encoder.

Routing Aux Busses and Variable Group Busses to Direct Outputs

Any of the Aux bus or Variable Group outputs can be routed to the Direct Outputs, up to the maximum of 32 Direct Outputs. For more information, see “Direct Outputs” on page 76.

Using Inserts on Aux Bus and Variable Group Bus Outputs

You can insert D-Show software plug-ins or hardware inserts on Aux bus or Variable Group bus outputs. For more information, see “Using Inserts on Output Busses” on page 72.

Inserting the Built-In Graphic EQ on Aux Bus and Variable Group Bus Outputs

A built-in 31-band Graphic EQ can be inserted on Aux bus or Variable Group outputs. For more information, see “Inserting the Built-In Graphic EQ on Output Busses” on page 73.

Chapter 11: Matrix Mixers and PQ Mixers

The D-Show Outputs section offers 8 Matrix mixers and 8 PQ mixers for setting up alternate mixes, fill and delay tower feeds, and cue or monitor mixes.

Inputs

Matrix mixers and PQ mixers can be configured independently to have different input sources. Matrix and PQ input sources can be controlled from the Assignable Output Encoders or on-screen.

Outputs

Matrix mixers have mono outputs and PQ Mixers have stereo outputs. Matrix and PQ outputs can be controlled from the Assignable Output Faders or on-screen.

Remote Control of PQ Mixers (Optional)

With optional PQ Controllers, PQ sources and outputs can be controlled remotely. If no PQ Controllers are used, the PQ mixers are still available for use as stereo matrix mixers controllable from the main console.

Matrix Mixers

Each of the 8 available Matrix mixers can receive up to 12 channels of input, including 8 channels from Groups or Auxes, 3 channels from the Mains (L-R+M or L-C-R), and a user-selected input. Each Matrix mixer has a mono output.



Matrix Mixer in Outputs page

Personal Q Mixers

Each of the 8 available Personal Q mixers can receive up to 12 channels of input, including 8 channels from Groups or Auxes, 3 channels from the Mains (L-R+M or L-C-R), and a user-selected input. Each Personal Q mixer has a stereo output.



Personal Q Mixer in Outputs page

Personal Q Controller System

With the optional Personal Q Controller system, performers can adjust the controls in the Personal Q mixer from a remote location. See the *Personal Q Guide* for details.

 *If no PQ Controllers are used, the PQ mixers are still available for use as stereo Matrix mixers controllable from the console.*

Configuring Matrix and PQ Mixers

The input sources for Matrix mixers and PQ mixers are configured in the Pickoffs tab of the Options page.

Groups and Auxes

The first 8 inputs to the Matrix and PQ mixers can be set to receive signal from Group or Aux busses (pre- or post-fader):

Groups

Mono Group Configuration If the 8 Group busses are configured to be mono, all 8 Groups appear on the Matrix or PQ mixer.

Stereo Group Configuration If the 8 Group busses are configured to be stereo, only the left and right channels of Groups 1–4 appear on the Matrix or PQ mixer. (The outputs of stereo Groups 5–8 are unavailable.) Adjacent inputs can also be linked or unlinked (see “Linking and Unlinking Adjacent Matrix and PQ Inputs” on page 94).

Auxes

8 Aux Configuration If the system is configured to have 8 Aux busses, all 8 appear on the Matrix or PQ mixer.

16 Aux Configuration If the system is configured to have 16 Aux busses, only Auxes 1–8 appear on the Matrix or PQ mixer. (The outputs of Auxes 9–16 are unavailable.)

Mains

The next 3 inputs to the Matrix and PQ mixers can receive signal from the Main busses (pre- or post-fader). The channel names reflect whether the Mains are configured as L-R+M or L-C-R.

To configure the Matrix and PQ mixers:

- 1 Go to the Options page and click the Pickoffs tab.
- 2 Under Matrix Sources, select the input source for channels 1–8 of the Matrix mixer and for channels 1–8 of the PQ mixer. Choices include Groups (pre- or post-fader) and Auxes (pre- or post-fader).
- 3 Select the input source for the Mains channels of the Matrix mixer and the PQ mixer. Choices include pre-fader or post-fader.

The Group, Aux and Main configurations are applied globally to all 8 Matrix mixers or PQ mixers.

User Input

The last channel of the Matrix and PQ mixers can receive signal from any Input Channel, FX Return, or hardware input. This User Input can be set individually for each Matrix mixer and PQ mixer, allowing for a variety of custom feeds and cue mixes.

To configure the User input for a Matrix or PQ mixer:

- 1 Press the Assign switch (located under the User Send encoder) to go to the Outputs page.
- 2 Select a Matrix channel or PQ channel to display the mixer you want to configure.
- 3 Click the on-screen Source pop-up menu and choose an input source.



Choosing an Input Source for the User Input

- 4 If the Input Source is an Input Channel or an FX Return, choose a pickoff point for the input from the Pickoff pop-up menu.

Choices include Top of Channel, Insert Return, and Pre/Post-Fader (for Input Channels) or Top of FX Return and Pre/Post-Fader (for FX Returns). The Input Channel Fader Pickoff setting determines globally whether the fader pickoff points are pre- or post-fader.

Adjusting Matrix Mixer and PQ Mixer Input Controls

Matrix and PQ Mixer Input Levels

The levels for the first 8 input sources (or “sends”) of a Matrix or PQ mixer are controlled by the Assignable Output Encoders. The levels for the Mains inputs of a Matrix or PQ mixer are controlled by the encoders marked *Left Send*, *Center Send*, and *Right Send*. The level for the user-selected input is controlled by the encoder marked *User Send*.

To control mixer input source (“send”) levels:

- 1 Press the Matrix Sends switch or the PQ Sends switch in the Output Encoder assignment section.

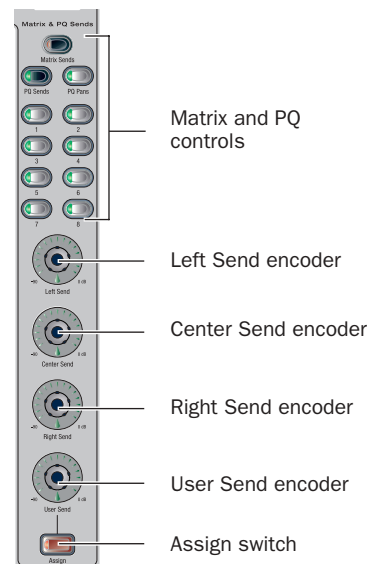

Matrix and PQ mixer controls

- 2 Press any of the numbered Send switches (1–8) to assign the corresponding Matrix mixer or PQ mixer to the Assignable Output Encoders and mixer Send encoders.
- 3 For each of the mixer input sources you want to activate, press the encoder knob so that its “On” indicator LED lights.
- 4 Turn the rotary encoder knobs 1–8 and the Left Send, Center Send, Right Send, and User Send encoders to set the level for the corresponding mixer input.

PQ Mixer Input Pan

The PQ mixer input (or “send”) pan controls adjust the panning of each PQ mixer input across the stereo outputs of the PQ mixer. (Matrix mixers have mono outputs, so they do not have Pan controls.)

To control PQ send pan:

- 1 Press the PQ Pans switch in the Output Encoder assignment section.
- 2 Press any of the numbered Send switches (1–8) to assign the corresponding PQ 1–8 mixer to the Assignable Output Encoders and mixer Send encoders.
- 3 Turn the rotary encoder knobs 1–8 and the Left Send, Center Send, Right Send, and User Send encoders to set the pan position of the corresponding mixer input.

Resetting Matrix Mixer and PQ Mixer Input Controls

To reset a Matrix mixer or PQ mixer parameter to its default value:

- 1 Select the Matrix mixer or PQ mixer you want to change so that it is displayed on-screen.
- 2 Right-click the encoder on-screen and choose Reset.

To reset all Matrix mixer or PQ mixer parameters to their default values:

- 1 Select the Matrix mixer or PQ mixer you want to change so that it is displayed on-screen.
- 2 Click the pop-up menu at the bottom of the mixer area and choose Reset Mix.

Copying Matrix Mixer and PQ Mixer Input Settings

You can copy mixer settings from one Matrix mixer or PQ mixer to another mixer of the same type. This lets you quickly duplicate monitor mixes or other signal feeds.

⚠ Copying mixer settings overwrites all the settings on the destination mixer.

To copy settings between mixers:

- 1 Select the Matrix mixer or PQ mixer that you want to be the destination of the copied settings so that it is displayed on-screen.
- 2 Click the pop-up menu at the bottom of the mixer area, choose Replace With Mix From, then choose the mixer whose settings you want to copy to the current mixer.

Linking and Unlinking Adjacent Matrix and PQ Inputs

Adjacent inputs to Matrix and PQ mixers can be linked or unlinked on a per input pair basis. Link status can be specified on a per PQ or Matrix basis (for example, inputs 1 and 2 can be linked for PQ 1, but unlinked for PQ 2). This gives you the ability to control inputs as either a stereo-linked pair or as independent mono inputs.

- ◆ When linked, level and source on/off controls are linked.
- ◆ When unlinked, discrete level and on/off controls affect each individual channel.

Stereo inputs (such as stereo groups, Mains LR, and stereo-linked auxes) are linked by default. Adjacent inputs can be linked or unlinked at any time, in Config or Show mode.

To link or unlink inputs to Matrix or PQ mixers:

- 1 Go to the Outputs page, and click to display the Matrix or PQ mixer.
- 2 Click the checkboxes below any adjacent inputs to link or unlink them. A check mark in the checkbox indicates a linked input source; an empty checkbox indicates unlinked sources.

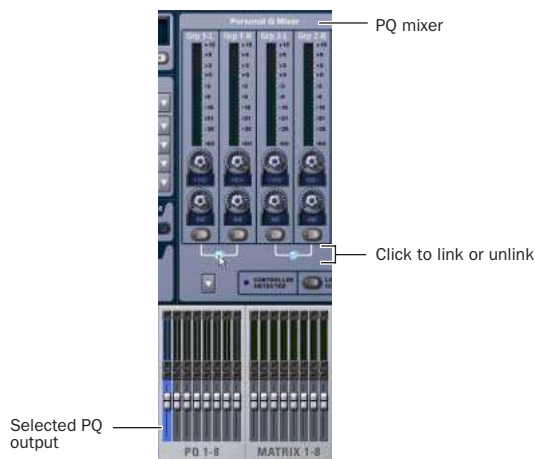

Link controls in the PQ page

Relinking and Offsets

When inputs are relinked, their level and on/off state will change as follows:

Level Each channel maintains any offset between the two channels. This offset is not maintained if both linked controls are adjusted beyond their maximum or minimum.

On/Off Each channel maintains its discrete on/off state at the time the sources are relinked. For example, if one channel is on and the other is off the stereo input will maintain these settings after relinking, thus providing a stereo source with one channel on, and the other off. Toggling one channel from Off to On results in both channels switching On; toggling one of the linked channels from On to Off results in both channels switching Off.

Adjusting Matrix Mixer and PQ Mixer Output Controls

Matrix and PQ Mixer Output Levels

See “Adjusting Output Controls” on page 74.

PQ Mixer Output Limiter

A limiter can be applied to the output of PQ mixers. PQ output limiter controls appear on-screen only. (Matrix mixers do not have output limiters.)

To use a limiter on the output of a PQ mixer:

- 1 Go to the Outputs page.
- 2 Select a PQ channel to display the mixer you want to configure.
- 3 Click the on-screen Limiter In button to engage the limiter.
- 4 Drag the on-screen Limiter knob to set the limiter threshold.

PQ Mixer Output Balance

PQ Mixers provide a balance control for controlling the balance of the mixer output signal across its stereo outputs. (Matrix mixers have mono outputs, so they do not have Balance controls.)

To control PQ mixer output balance:

- 1 Target the PQ mixer output channel by pressing its Select switch in the Assignable Output Faders section.
- 2 Turn the Pan rotary encoder at the lower left of the ACS section to adjust the balance for the mixer output.

Matrix and PQ Mixer Output Polarity

See “Output Polarity (Phase) Invert” on page 74.

Matrix and PQ Mixer Output Solo

See “Output Solo” on page 74.

Matrix and PQ Mixer Output Mute

See “Output Mute” on page 75.

Matrix Mixer Output Delay

A variable delay (0–500 ms) can be applied to the output of Matrix mixers.

To apply delay to a Matrix mixer output:

- 1 Target the Matrix mixer output channel by pressing its Select switch in the Assignable Output Faders section.
- 2 Press the ACS Delay rotary encoder to apply the delay to the mixer output.
- 3 Adjust the delay value by turning the Delay rotary encoder.

Matrix and PQ Mixer Direct Output

Matrix and PQ mixers have Direct Output capability. For more information, see “Direct Outputs” on page 76.

Matrix and PQ Mixer Delay Compensation

D-Show automatically compensates for delays incurred by the use of Groups and the insertion of plug-ins in the signal path to the Main busses.

Using Inserts on Matrix and PQ Mixer Outputs

You can insert D-Show software plug-ins or hardware inserts on Matrix and PQ mixer outputs. For more information, see “Using Inserts on Output Busses” on page 72.

Inserting the Built-In Graphic EQ on Matrix and PQ Mixer Outputs

A built-in 31-band Graphic EQ can be inserted on mixer output channels. For more information, see “Inserting the Built-In Graphic EQ on Output Busses” on page 73.

Working with a PQ Controller

When an optional Personal Q remote control system is connected to D-Show, it can be used to adjust the controls in the Personal Q mixers from a remote location.

For complete instructions on connecting and using PQ Controllers, refer to the *Personal Q Controller Guide*, included with the PQ Controller system.

Controller Detection

When a PQ Controller is detected, the Controller Detected indicator lights in the corresponding Personal Q mixer on-screen window.



PQ Controller Detected indicator in PQ mixer

Controller Lockout

Lockout From Console The PQ Controller can be locked out by clicking the on-screen Lockout From Console button in any of the PQ mixers. When this Lockout button is engaged, the PQ Controller cannot adjust PQ mixer controls. The performer using the PQ Controller cannot override this lockout from the controller.

Lockout From Controller Users can lock their PQ Controllers to prevent inadvertent changes to controller settings. When this is done, the on-screen Lockout From Controller indicator lights in the corresponding PQ mixer. This function does not lock out control of the PQ mixer from the console.

Calling the D-Show Console from the PQ Controller

To call the console from a Personal Q Controller:

- Press the Master Volume encoder knob.

A call message appears on the D-Show console display that identifies which PQ Controller is calling. The Call LED on the PQ Controller flashes until the message is cleared from the console display.

Chapter 12: Patchbay

Accessing the Patchbay

To show the Patchbay screen:

- Press the Patchbay switch, located in the View Modes section, or click the Patchbay page name on-screen.

Jump to Patchbay from Inputs and Outputs Screens

The Inputs and Outputs screens provide a shortcut for accessing the Patchbay. By clicking on the channel routing indicator, the screen automatically jumps to the corresponding Patchbay screen (whether an input, output, or bus).



Overview of the Patchbay

The Patchbay screen lets you patch hardware I/O to D-Show input and output channels.

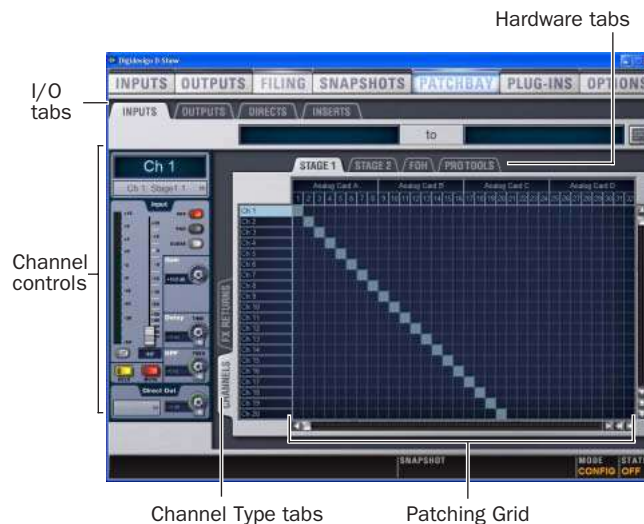

Patchbay page (Inputs tab shown)

The main tools and sections of the Patchbay screen are the following:

Tabs

The Patchbay is navigated using the following tabs.

I/O Tabs

Click to display and patch D-Show Inputs, Outputs, Directs, or Inserts. Other options in the Patchbay screen change to reflect the currently selected I/O tab.

Channel Type Tabs

Click these tabs to select specific types of D-Show Channels, as available for the currently selected I/O. The following table shows the available Channel Types for the current I/O.

I/O tab	Channel Types available
Inputs	Channels, FX Returns
Outputs	Groups, Auxes, Matrix, PQ, Mains
Directs	Channels, FX Returns, Outputs
Inserts	Channels, FX Returns, Outputs

Hardware Tabs

Click these tabs to display the hardware inputs and outputs available for the current I/O and Channel Type. These represent the physical inputs and outputs of the system.

Choices include Stage Rack 1, Stage Rack 2, FOH, and any Pro Tools recording/playback options, displaying available analog and digital inputs. Available hardware inputs and outputs are based on channel type selection, system configuration and hardware device status. See “Unavailable I/O” on page 98.

Patching Grid

The Patching Grid shows hardware I/O across the top, and D-Show channels down the left side for the currently selected I/O and Channel type. The grid squares represent patch points between hardware I/O and D-Show channels.

You can customize the routing of hardware I/O to D-Show channels by clicking and dragging in the corresponding squares in the grid. For complete patching instructions see “Routing Channels in the Patchbay” on page 100.

By default, inputs are routed in a 1-to-1 pattern to D-Show input channels resulting in Stage Rack inputs 1–24 appearing on D-Show Input Channels 1–24.

Channel Controls

These controls mirror the controls for the currently selected channel. For example, when showing Inputs, the Channel controls let you adjust Input Channel gain, polarity, phantom power, HPF, and basic level without leaving the Patchbay.

Channel Direct Outs

The channel area in the Patchbay provides access to all Direct Out controls (the Inputs and Outputs pages do not show the Direct Output level control).

To adjust Direct Output level from the Patchbay:

- 1 In the Inputs or Outputs page, select a channel.
- 2 Click the Direct Out routing selector to go to the Patchbay.
- 3 In the Patchbay channel controls, adjust the on-screen Direct Output encoder.



Adjusting Direct Output level from the Patchbay

Visual Indicators and Displays

The Patchbay uses the following visual display conventions in all its pages and tabs.

Unavailable I/O

The Patchbay displays hardware tabs for all possible configurations, even if your system does not include any expansion options.

The Patchbay indicates I/O that is offline or unavailable by graying out the columns beneath that device.

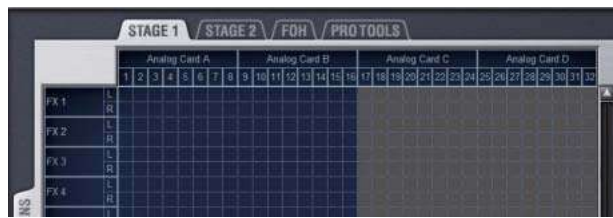

Unavailable I/O

Unavailable I/O (grayed columns)

Hardware I/O channels appear as unavailable whenever the required hardware is not present or offline. Hardware includes Stage Racks, FOH Racks, and audio cards installed in them. A hardware device is offline if it is not powered on, not communicating with the system, or it represents an expansion option that is not installed.

Even if hardware is unavailable, you can still assign routing from or to it in the Patchbay. Unavailable I/O appears *italicized* in all routing pop-up lists (such as the Inputs and Outputs screens).

Hardware I/O availability is saved with Show files, which store the status of hardware at the time of the last save performed at the system.

The D-Show Standalone software provides additional display options for hardware I/O (including unavailable I/O).

📖 See Chapter 23, “Using the D-Show Standalone Software.”

Assigned I/O

When a hardware I/O channel is assigned, its channel number is darkened in all Patchbay screens. This lets you see which hardware channels are in use without having to switch back and forth between Patchbay screens. You can also use the dimmed column number indicator to jump to the Patchbay tab for the existing assignment (for more information, see “Shortcut for Locating Assignments” on page 102).

Text Display of Patch Source and Destination

Above the grid tabs, there are “from” and “to” text display fields that display the full text names of hardware I/O and D-Show channels.

To view full names of a patch source and destination:

- Place the cursor over a Channel Name. If the channel is already routed, its source and destination assignment appear directly above the Patching Grid, as shown below.

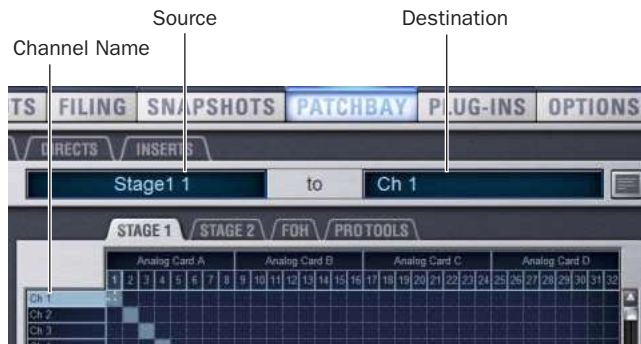

Channel source and destination display

An asterisk at the end of a destination name indicates a multiple output assignment. See “Multiple Input and Output Assignments in the Patchbay” on page 101.

Naming Channels from the Patchbay

Channel names can be changed from the Patchbay. Channel names can be up to 32 characters in length. When displayed on the control surface, names are abbreviated to fit the display.

To name or rename a channel from the Patchbay:

- 1 Double-click the channel name.
- 2 Type a new name and press Enter on the computer keyboard.

 When naming channels in the Patchbay, press Tab on the keyboard to go to the next channel and Shift+Tab to go to the previous channel.

Type Text Search

Type Text search lets you use the keyboard for fast navigation to a channel. You can enter the first characters of a channel name or the absolute channel number to target that channel on the ACS.

To search for and select a channel:

- 1 Type the first few letters, full name, or channel number of the channel. For example, type “s” to go to the first channel beginning with the letter s (such as *Snare*).
- 2 Press the Tab key to cycle through and select any other channels beginning with that letter (such as *Snare Top*, *Snare Bottom*, or *Strings*).

 Avoid giving channels names that begin with numbers different from the absolute channel number. When you type a number, D-Show navigates to absolute channel numbers regardless of the channel name.

Navigating the Patchbay

Navigating to Channel Types

The Patchbay uses multiple tabs to access different hardware I/O and channel types. For example, the Inputs screen provides Channels and FX Returns tabs for you to patch these different channel types independently.

To show Inputs:

- Go to the Patchbay page and click the Inputs tab.

To show a specific type of Input:

- In the Patchbay page, click the Channels tab, or the FX Returns tab. Shift-Click to select and show multiple types at once.

To show Outputs:

- In the Patchbay page, click the Outputs tab.

To show a specific type of Output:

- In the Patchbay, click an output Channel Type tab (Groups, Auxes, Matrix, PQ, or Mains).

Use these same techniques to access Directs (direct outs) and Inserts.

Navigating to Hardware Sources

To navigate to a different hardware source:

- Click the appropriate Hardware tab across the top of the Patching Grid.

Scrolling in the Patchbay

To scroll through the channel list (vertically):

- 1 Move the cursor over a channel name at the left of the Patching Grid.
- 2 Press the Up or Down Arrow keys on the keyboard.

To scroll through the hardware I/O list (horizontally):

- 1 Move the cursor over a hardware I/O channel at the top of the Patching Grid.
- 2 Press the Left or Right Arrow keys on the keyboard.

To scroll the Patching Grid, do one of the following:

- Click the up/down or left/right Patching Grid scroll arrows to move square by square.
- Click the up or down Patching Grid double arrows to move screen by screen.
- Right-click in the Patching Grid and drag in any direction.



Scrolling the Patching Grid by right-clicking and dragging

Routing Channels in the Patchbay

To route channels in the Patchbay:

- 1 Go to a patchbay page by clicking the appropriate I/O tab, Channel Type tab, and Hardware tab.
- 2 Place the cursor over the Patching Grid. The cursor changes to a crosshair, and lines extend above and to the left of the current cursor location to identify the column and row in which it is located.
- 3 Click in the row for the channel and in the column for the hardware I/O source. For example, to route Stage Rack analog input 4 to D-Show Input Channel 4, click in row 4, column 4 as shown below.

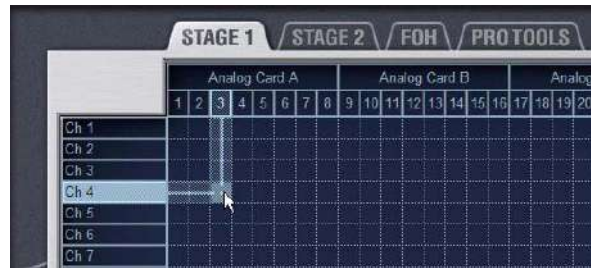

Routing a hardware input to an Input Channel

- 4 Click and drag vertically, horizontally, or at an angle to assign multiple patch points in a single action.
- 5 Repeat as needed.

Patchbay Click and Drag

You can quickly select a range of crosspoints in the Patchbay grid in one operation with a left-click and drag of the cursor. You can click and drag horizontally, vertically, and at 45-degree angles in any direction.

⚠ You cannot undo changes to the Patchbay grid.

To use click and drag in the Patchbay grid:

- 1 Left-click on the crosspoint defining the start of the range.
- 2 Continue to hold the left-click button, then drag horizontally (to populate a row), vertically (to populate a column), or horizontally and vertically (a 45-degree angle).
- 3 Release the left-click button when the destination crosspoint is reached. All crosspoints along the path are filled in.

The destination crosspoint sets the targeted channel. If the new assignments steal any previous assignments, a warning dialog will ask you to confirm or cancel the reassignment.

SHIFT To suppress the reassignment warning dialog, hold Default (on the control surface) or Alt (on the computer keyboard) while clicking in the patch grid. For more information, see “Warning when Stealing Inputs or Outputs in the Patchbay” on page 102.

Using the Arrow Keys to Route Channels

You can also use the Arrow keys instead of the trackball to assign routing.

To route channels using the Arrow Keys on the keyboard:

- 1 Place the cursor over the Patching Grid so that the cursor changes to the crosshair.
- 2 Press the Left or Right Arrow keys to move the crosshair to the next or previous hardware I/O column; press the Down or Up Arrow keys to move the cursor to the next or previous D-Show channel.
- 3 When the crosshair is over the correct square in the grid, press Enter to assign the patch.

Multiple Input and Output Assignments in the Patchbay

Input sources can be routed to multiple Input Channels in the Patchbay. In addition, Output busses can be routed to multiple hardware outputs.

Stage Rack inputs routed to multiple channels share a common preamp gain. Adjusting one channel's gain automatically adjusts all other channels. All other channel functions (such as EQ, dynamics, and panning) remain independent.

To route a hardware input source to multiple Input Channels or FX Returns:

- 1 Go to the appropriate Input display in the Patchbay.
- 2 Click in the Patching Grid to route the source to the first Input Channel or FX Return.
- 3 Click additional grid squares in the same column to route the source to additional channels. The selected hardware input is routed to each of the assigned Input Channels or FX Returns.

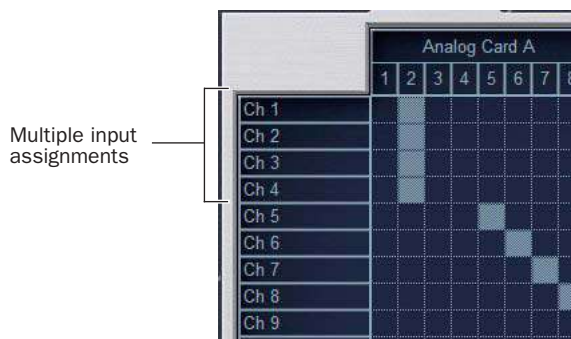

A hardware input routed to multiple Input Channels

To route a D-Show Output bus to multiple hardware outputs:

- 1 Go to the appropriate Output display in the Patchbay.
- 2 Click in the Patching Grid to route the Output bus to the first hardware output.

- 3 Click additional grid squares in the same row to route the same Output bus to additional hardware outputs. The selected bus is routed to all the assigned hardware outputs. An asterisk (*) appears at the end of the displayed destination to indicate the multiple routing.

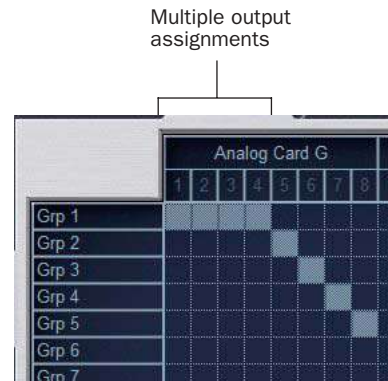

An Output bus routed to multiple hardware outputs

Direct Outputs and Routing in the Patchbay

A maximum of 32 Direct Outputs can be active at one time. You can specify the pickoff point for Direct Outputs directly from the Patchbay. For more information, see "Direct Outputs" on page 76.

Direct Output Pickoff Points

D-Show lets you specify the pickoff point from which Direct Outputs are sourced.

To specify a Direct Out pickoff point:

- 1 Navigate the Patchbay to the Outputs > Directs screen.
- 2 For each Direct Out, click in the Pickoff column located between the channel names and the Patching Grid, then choose a pickoff point.



Specifying the source for a Direct Out channel

Inserts and Routing in the Patchbay

Hardware inserts are available on all D-Show channels to incorporate external hardware processing. D-Show inserts can only be routed to and from the FOH Rack.

Inserts patching uses the same techniques as other Patchbay routing.

 See Chapter 18, “Hardware Inserts.”

To use a hardware insert on a D-Show channel:

- 1 Connect the hardware device to D-Show FOH Rack Insert connectors.
- 2 In the Patchbay, route the channel to the FOH Rack I/O to which the hardware device is connected.

 *Input and Output routing can be stored and recalled using Snapshots. For more information, see Chapter 21, “Snapshots.”*

Warning when Stealing Inputs or Outputs in the Patchbay

The Patchbay indicates hardware outputs that are already in use by dimming the column number for that physical output. In addition, a dialog is shown if the patch will steal a hardware input or output that is already in use, asking you to confirm or cancel the reassignment.

To confirm a reassignment, do one of the following:

- Click Assign when prompted to confirm the reassignment.
– or –
- Click again on the same patch point.

To cancel a reassignment:

- Click Cancel to cancel the reassignment and leave the patchpoint unchanged.
– or –
- Click any other point in the grid (the Patchbay grid remains active, even when the Confirm Assignment dialog is open on-screen).

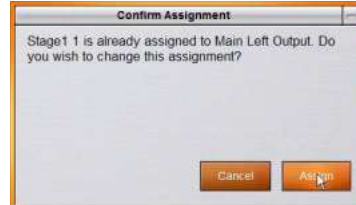

Warning when reassigning an output that is already in use

 To suppress the reassignment warning dialog, hold Default (on the control surface) or Alt (on the computer keyboard) while clicking in the patch grid to change the assignment.

Shortcut for Locating Assignments

Before reassigning in the Patchbay, you may want to double-check the existing assignment to the desired hardware output. This can be done quickly from within the Patchbay, as follows:

To identify the bus or channels currently assigned to a hardware output:

- Click on any dimmed (already assigned) column number at the top of the Patchbay. The Outputs tab containing the assignment is automatically revealed.



Column numbers to “go to” the current assignment

Chapter 13: Metering

D-Show provides signal metering on the control surface channels and meter bridge, and on-screen.

Channel Meters

All control surface channel meters have on-screen equivalents that appear in both the targeted channel controls and just above the faders in the channel overview.

Meter ballistics and clip margin can be set for channel meters. For more information, see “Metering Options” on page 107.

Input Channels and FX Returns

Input Level Meters

Each Input Channel and FX Return channel strip has a 10-segment bi-color Input Level meter.

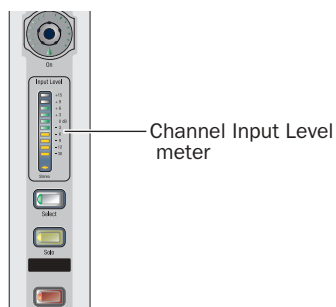

Channel Input Level meter

The 10 bi-color LEDs on the Input Level meters show input levels from bottom to top, according to the following scale:

Channel Input Level meter scale

LED	Level	Color
1 (top)	15 dB	Yellow
2	9 dB	Yellow
3	6 dB	Yellow
4	3 dB	Yellow
5	0 dB	Green
6	-3 dB	Green

Channel Input Level meter scale

LED	Level	Color
7	-6 dB	Green
8	-9 dB	Green
9	-12 dB	Green
10 (bottom)	-30 dB	Green

Dynamics Gain Reduction Meters

Each Input Channel and FX Return channel strip has two gain reduction meters that show the amount of gain reduction applied by the built-in Compressor/Limiter (6-segment meter) or Expander/Gate (3-segment meter).

Compressor/Limiter Meter

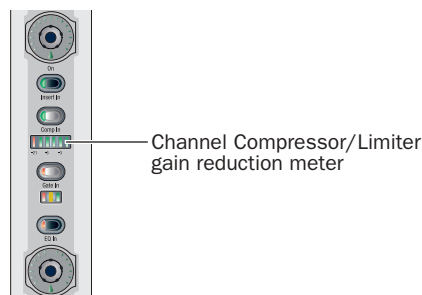

Channel Compressor/Limiter meter

The 6 LEDs on the Compressor/Limiter meter show gain reduction levels from right to left, according to the following scale:

Channel Compressor/Limiter gain reduction meter scale

LED	Gain Reduction	Color
(none)	0 dB	(none)
1 (right)	3 dB	Green
2	6 dB	Green
3	9 dB	Green
4	12 dB	Green
5	15 dB	Green
6 (left)	21 dB	Red

Expander/Gate Meter



Channel Expander/Gate gain reduction meter

Channel Expander/Gate meter

The Expander/Gate meter works differently depending on which mode the strip is in. The meter is in Gate mode when the ratio is set to its maximum setting (100:1).

Gate When the Gate function is selected, the 3 LEDs on the Expander/Gate meter show the following:

Gate status

LED	Status	Color
1 (right)	Gate open	Green
2	Gate in hold	Yellow
3 (left)	Gate closed	Red

Expander When the Expander function is selected, the 3 LEDs on the Expander/Gate meter show gain reduction levels from right to left, according to the following scale:

Expander gain reduction meter scale

LED	Gain Reduction	Color
(none)	0 dB	(none)
1 (right)	3 dB	Green
2	20 dB	Yellow
3 (left)	> 20 dB	Red

Bank Clip Indicators

The Bank Clip LED at the top of Input Channel and FX Return channel strip lights when clipping occurs on a hidden fader bank. The channel position of the Bank Clip indication corresponds to the position of the off-bank channel. The Bank Clip LED flashes to indicate momentary clips, and lights solid for sustained clipping.

To locate the clipped channel:

- Press the Channel Bank switches until the Channel Input Level meters show clipping.

For more information on clip indication, see “Metering Options” on page 107.

Stereo LED

The Stereo LED on Channel Input Level meters lights to indicate stereo channels. A flashing Stereo LED indicates there is an offset in level between left and right signals of 12 dB or more.

ACS Section Dynamics Meters

The three dynamics gain reduction meters in the ACS section show gain reduction for the built-in Compressor/Limiter, the built-in Expander/Gate, and any applicable Dynamics plug-in on the selected channel.

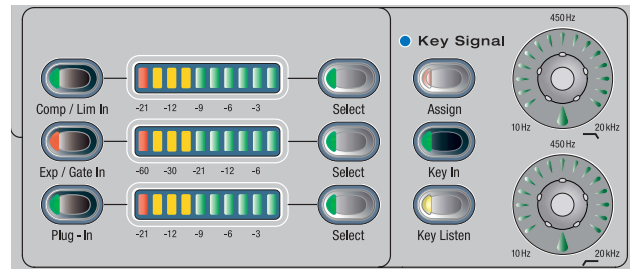

ACS dynamics gain reduction meters

On each meter, the 10 LEDs show dynamics gain reduction from right to left, according to the following scale:

ACS gain reduction meter scale

LED	Gain Reduction	Color
(none)	0 dB	(none)
1 (right)	3 dB	Green
2	6 dB	Green
3	9 dB	Green
4	12 dB	Green
5	15 dB	Green
6	21 dB	Green
7	24 dB	Yellow
8	30 dB	Yellow
9	40 dB	Yellow
10 (left)	60 dB	Red

Meter Bridge

The D-Show meter bridge includes meters for the selected channel, the Output section, and the Main Outputs.

All of the 20-segment meters in the meter bridge show levels according to the following scale:

Table 14. Meter bridge 20-segment meter scale

LED	Level
1 (top)	+15 dB
2	+12 dB
3	+9 dB
4	+6 dB
5	+3 dB
6	+1 dB
7	0 dB
8	-1 dB
9	-3 dB
10	-6 dB
11	-9 dB
12	-12 dB
13	-15 dB
14	-18 dB
15	-21 dB
16	-24 dB
17	-30 dB
18	-40 dB
19	-50 dB
20	-60 dB

Selected Channel and Solo Bus Meters

The Selected Channel meters in the meter bridge include two 20-segment bi-color level meters and two 10-segment dynamics gain reduction meters.

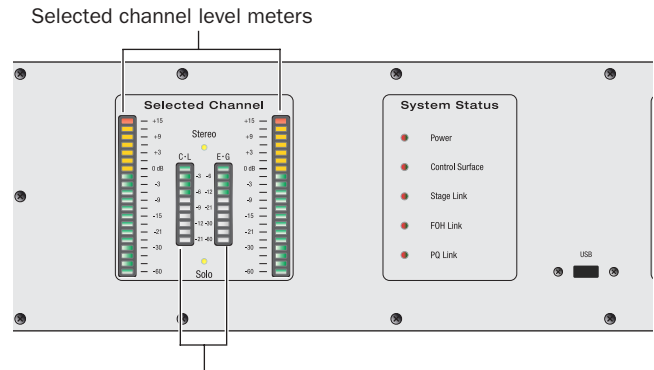

Selected channel level meters
Selected channel gain reduction meters
Selected channel meters in the meter bridge

Selected Channel Level Meters

These meters show mono or stereo levels on the selected channel. The 20 bi-color LEDs show input from bottom to top, according to the scale shown in Table 14 on page 105.

Selected Channel Dynamics Gain Reduction Meters

These meters show gain reduction for the built-in Compressor/Limiter and the built-in Expander/Gate on the selected channel. The 10 LEDs show dynamics gain reduction for the selected channel, from top to bottom, according to the following scale:

Selected channel dynamic gain reduction meter scale

LED	Gain Reduction	Color
(none)	0 dB	(none)
1 (top)	3 dB	Green
2	6 dB	Green
3	9 dB	Green
4	12 dB	Green
5	15 dB	Green
6	21 dB	Green
7	24 dB	Green
8	30 dB	Green
9	40 dB	Green
10 (bottom)	60 dB	Red

Output Section Meters

The eight output level meters in the meter bridge are assignable as a unit for metering of any of the following output types: Groups, Auxes, Matrixes, and Personal Qs.

Stereo Output Metering

With stereo Groups and Personal Qs (which are always stereo), the output level meters in the meter bridge show level for only the highest of the left and right channels.

To see level for both the left and right channels of a stereo output, refer to the on-screen meters, or target the channel on the ACS and use the Selected Channel Level Meters.

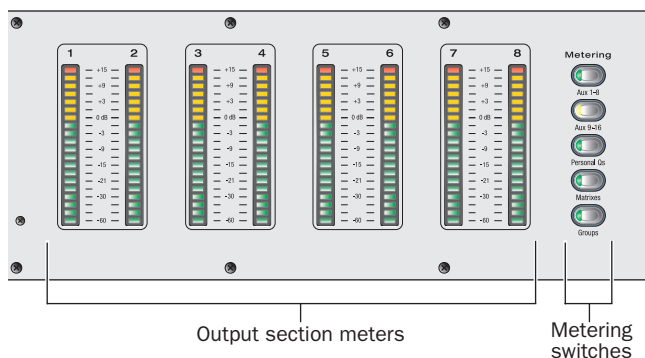

Output level meters in the meter bridge

The 20 bi-color LEDs show input levels from bottom to top, according to the scale shown in Table 14 on page 105.

Selecting Output Meter Display

Output meter display is controlled from the Metering switches to the right of the meters. If no output type is selected, the output meters in the meter bridge follow the output assignment on the Assignable Output Faders.

To select an output type for metering:

- Press the corresponding Metering switch.

To set metering to follow the Assignable Output Faders:

- Press the lit Metering switch to cancel the selection.

Main Output Meters

The three Main output meters in the meter bridge show output levels for the three Main outputs (either in L-C-R or in L-R+M format).

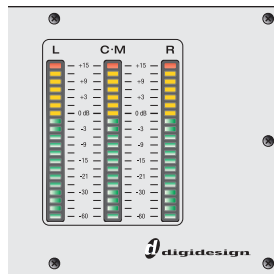

Main output level meters in the meter bridge

The 20 bi-color LEDs show input levels from bottom to top, according to the scale shown in Table 14 on page 105.

Metering on the Solo Bus

Metering Soloed Channels

Solo bus metering depends on the type of channel being soloed.

Single Channels

In PFL, AFL, or SIP modes, a single soloed channel is metered in the same way as if the channel were targeted on the ACS.

Multiple Channels

In PFL or AFL mode, when multiple channels are soloed, the left and right channels of the Solo bus are metered on the Selected Channel meters, pre-Solo Trim control.

In SIP mode, when multiple channels are soloed, the Left and Right Main bus meters are mirrored on the Selected Channel meters.

Dynamics Key Listen

When Key Listen is activated, the left and right channels of the Solo bus are metered on the Selected Channel meters, pre-Solo Trim control.

Solo Clip Indication

When the Selected Channel meters are showing levels of a single soloed channel, the clipping information on the meter bridge LEDs mirrors that on the channel itself.

When the Selected Channel meters in the meter bridge are showing Solo bus levels, the meter LEDs turn red to indicate clipping on the Solo bus.

Metering Options

Meter Display

The following display options can be configured for D-Show meters. These options affect all meters on the control surface, including input, output, and ACS meters, as well as all on-screen meters.



Metering options in the Interactions tab of the Options page

Meter Ballistics

Meters can be set to operate in the following modes:

RMS Mode Meters follow the characteristics of a damped analog meter. In this mode, the meter response and decay is slower than in Peak mode, providing an average reading of the metered signal. A single LED shows the peak level for the designated Peak Hold Time.

Peak Mode Meters follow the characteristics of a standard peak meter. In this mode, the meter response is instantaneous, showing the true peak level of the metered signal.

Peak Hold Time

Peak Hold Time can be set within a range of 0–20 seconds.

To set the Peak Hold Time:

- 1 Go to the Options page and click the Interactions tab.
- 2 Under Meter, enter a value for the Peak Hold Time.
- 3 Press Enter on the keyboard.

Clipping Indication

D-Show meter clip indicators are proximity warnings that show when an input or output signal reaches or exceeds the configured Clip Margin.

Clipping is indicated by all of a meter's LED segments turning red. The LEDs stay red for the designated Clip Hold Time.

Clipping can occur at several points throughout the signal chain. A clip at any one of these points is indicated on the meter. For more information on the location of D-Show clip detect points, refer to Chapter 26, "Signal Flow Diagrams."

Clip Margin

The Clip Margin setting lets you configure the amount of headroom you want before clipping indication begins. Clip Margin is expressed as *dB below maximum* (where maximum is a peak level of +20 dBVU).

Clip Margin can be set within a range of 0 dB to 30 dB below maximum, and is configured separately for inputs and outputs.

To set the Clip Margin:

- 1 Go to the Options page and click the Interaction tab.
- 2 Under Meter, enter values for Input Clip Margin and Output Clip Margin.
- 3 Press Enter to confirm the setting.

Clip Hold Time

The Clip Hold Time determines how long a clip indication lasts after the last clipped signal. Clip Hold Time can be set within a range of 0–20 seconds.

To set the Clip Hold Time:

- 1 Go to the Options page and click the Interaction tab.
- 2 Under Meter, enter a value for the Clip Hold Time.
- 3 Press Enter to confirm the setting.

Chapter 14: Solo and Monitor Busses

Solo Bus Modes

D-Show offers three modes for soloing channels in the system: Pre-Fader Listen (PFL), After-Fader Listen (AFL) and Solo In Place (SIP).

- ◆ In AFL or PFL mode, soloing only affects what you hear on the dedicated stereo AFL/PFL Solo bus, which feeds the Monitor Bus.
- ◆ In Solo In Place mode, soloing only affects what you hear in the Main busses.

Pre-Fader Listen (PFL)

PFL Solo mode sends the signal from explicitly soloed Input Channels and FX Returns to the AFL/PFL Solo bus. The signal is post-insert, pre-fader and pre-mute.

Mono input signals are sent to both sides of the Solo bus, and the left and right sides of stereo input signals are sent to the corresponding sides of the Solo bus.

PFL is the default Solo mode.

After-Fader Listen (AFL)

AFL Solo mode sends the signal from explicitly soloed channels and solo-safe inputs to the AFL/PFL Solo bus. Soloing of output busses is always AFL.

In AFL Solo mode, both input and output signals are sent to the Solo bus post-fader and post-pan/balance, and are always panned to stereo even if the Main busses are configured in L-C-R mode.

Monitoring Aux busses and Variable Group busses with AFL

Linked Aux busses and Variable Group busses use true stereo AFL. When you solo a linked Aux bus, the two busses are heard as a stereo pair on the Solo bus.

Mono Aux busses and Variable Group busses are heard as dual mono on the Solo bus.

You can set D-Show to automatically display Aux or Variable Group send controls on the Input Channel Encoders when the corresponding Aux or Variable Group output bus is soloed. See “Auxes/Variable Groups Follow AFL” on page 110.

Solo In Place (SIP)

SIP Solo mode applies to Input Channels and FX Returns only. Solo In Place sends the signal from the soloed channel to the Main busses. No signal is sent to the Solo busses. Signal is sent post-pan/balance.

⚠ In SIP Solo mode, audio is sent directly to the Main busses. Use this feature with caution.

To enter Solo In Place mode:

- Press and hold the SIP switch for 2 seconds. The SIP switch lights to indicate SIP mode is active.

To exit Solo in Place mode:

- Press the SIP or Cancel switch to exit SIP mode.

Selecting a Solo Mode

The Solo mode can be selected from the Solo/PFL section on the right side of the Main Unit, or on-screen.

To select the Solo mode from the Solo/PFL section, do one of the following:

- Press the Stereo AFL switch to enter AFL Solo mode.
- Press and hold the Solo In Place switch for at least 2 seconds to enter SIP mode.
- Press a lit Solo mode switch to turn it off. When no switch is lit in the Solo/PFL section, the system is in PFL mode.

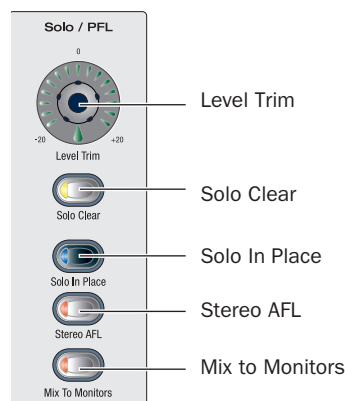

Solo bus controls on the control surface

To select the Solo mode on-screen:

- 1 Go to the Options page and click the Busses tab.
- 2 Under Solo and Monitor Operations, select the Solo mode.



Solo and Monitor Operations options

Solo States and Modes when Loading Shows

Channel Solo States

When you load a Show file, all solos are cleared. Solo states are not saved with Show files.

Solo Mode

Show files do not open in SIP mode. If you save a Show file while in SIP, when you reopen the Show file, it will open in AFL Solo mode.

Solo Operation Options

Momentary or Latching Switch Operation

Channel solo switches can operate with either momentary or latching behavior.

To engage momentary solo on a channel:

- Hold the solo switch for more than one second. Release the solo switch to unsolo the channel.

To latch solo on a channel:

- Press and release the solo switch. Press the switch a second time to unsolo the channel.

Auxes/Variable Groups Follow AFL

The “Auxes/Variable Groups Follow AFL” option is especially useful for monitor mixing, because it provides instant access to any mix by the soloing the mix output (in AFL mode).

When this option is selected, soloing an Aux output bus or Variable Group output bus (by pressing its AFL switch) causes the Send level and pan controls for that bus to be displayed on the Input Channel Encoder rows.

- ◆ Soloing a Variable Group bus automatically toggles display of Variable Groups on the Input Encoders.
- ◆ With mono Aux or Variable Group busses, Send level is displayed on the top row of Input Encoders.
- ◆ With stereo (linked) Aux or Variable Group busses, Send level is displayed on the top row, and Send pan is displayed on the bottom row of encoders.

 *If an Input Encoder row is flipped to the faders, flipped status is maintained when an Aux or Variable Group bus is soloed.*

To set Auxes and Variable Groups to display send controls when soloed:

- 1 Go to the Options page and click the Busses tab.
- 2 Under Solo and Monitor Operation, select the “Auxes Follow AFL” or “Auxes/Variable Groups Follow AFL” option.
- 3 Solo an Aux or Variable Group output bus by pressing its AFL switch.

To cancel display of Aux and Variable Group send controls:

- Unsolo the Aux or Variable Group output bus. The Input Encoder rows return to the previous display.
– or –
- Select any other parameter for the Input Channel Encoder row to override the Aux follows AFL display. The Input Encoder row displays the selected parameter until another output is soloed.

Auto Cancel and Input Priority

The Auto Cancel option determines whether Solo switches cancel other soloed channels or are additive (latching). The Input Priority option determines whether soloed inputs replaced soloed outputs on the AFL/PFL Solo bus.

To set Solo switch operation:

- 1 Go to the Options page and click the Busses tab.
- 2 Under Solo and Monitor Operation, select the options in any of the following combinations:

Auto Cancel On, Input Priority Off A solo cancels all other solos (inputs and outputs)

Auto Cancel On, Input Priority On An input solo cancels all other soloed inputs; an output solo cancels all other output solos; soloed inputs temporarily replace soloed outputs

Auto Cancel Off, Input Priority Off Solos are additive, and soloed inputs and outputs are heard together

Auto Cancel Off, Input Priority On Solos are additive, and soloed inputs temporarily replace soloed outputs.

Solo Bus Operation

Soloing Channels

Solo operation depends on the type of channel being soloed, and on any selected Solo switch options. In all modes, a channel's solo switch lights to indicate that the channel is soloed.

Input Channels

Pressing a Solo switch on an Input Channel or FX Return sends signal to the Solo bus (when in PFL or AFL modes) or to the Main bus (when in SIP mode).

In SIP mode only, when a channel is soloed, all other channels that are not soloed or solo safe are implicitly muted. Implicit mutes are indicated by a flashing mute switch.

Output Busses

When the AFL switch in the Assignable Output Encoders section or the Assignable Output Faders section is pressed, signal is sent to the AFL/PFL Solo bus. This applies to Groups, Auxes, Matrixes, and Personal Qs. Outputs are always AFL.

Soloing Single Channels

To solo a single channel, do one of the following:

- Press the channel's solo switch so it is lit. The solo switch latches on a momentary press.
 - or –
- Hold the channel solo switch for more than one second for momentary solo. The channel will automatically unsolo when you release the switch.

Soloing Multiple Channels

To solo multiple channels, do one of the following:

- With the Auto Cancel option enabled, press the Solo switches on multiple channels simultaneously.
 - or –
- With the Auto Cancel option disabled, press Solo switches on multiple channels in any sequence. The Solo switches latch on.

Toggleing the Solo Status of Multiple Channels

To toggle the Solo status of multiple channels, do one of the following:

- With the Auto Cancel option enabled, hold the Multi Select switch while pressing the Solo switches on channels you want to toggle.
 - or –
- With the Auto Cancel option disabled, press Solo switches in any sequence. The Solo switches latch on and off.

Soloing VCAs

When you solo a VCA, its member channels are soloed. If the VCA members include a combination of input and output channels, their solo status follows any Solo switch options. See "Solo Operation Options" on page 110.

To solo the members of a VCA:

- Press the Solo switch on the VCA channels whose members you want to solo so that the Solo switch is lit.

Clearing Solos

If any channel is soloed on the console, the Solo Clear switch in the Solo/PFL section flashes.

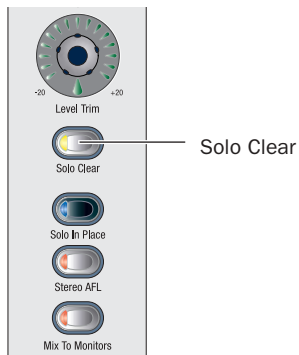

Solo Clear switch in the Solo/PFL section

To clear all solos on the console:

- Press the flashing Solo Clear switch.

Solo Bus Metering

When a channel or dynamics key input is sent to the Solo bus, its signal is metered on the Selected Channel meters on the meter bridge, temporarily replacing the metering for any currently targeted channel.

For more information, see “Metering on the Solo Bus” on page 106.

Solo Safing Channels

Only Input Channels and FX Returns can be made solo safe. Solo safed channels are automatically added to any explicitly soloed channels.

Solo Safe only applies to SIP and AFL mode. Solo safe status is ignored in PFL mode.

To toggle the solo safe status of Input Channels and FX Returns, the Safe switches must be set to control the Solo Safe function.

To set Safe switches to control the Solo Safe function:

- 1 Go to the Options page and click the Interaction tab.
- 2 Under Input Safe Switches, select “Act as Solo Safes.”

To toggle the solo safe status of a channel, do one of the following:

- Press the Safe switch on the channel.
 - or –
- Click the on-screen Solo Safe button for the channel.



On-screen Solo Safe button

The Safe switch and button flash to indicate the channel is solo safe. When a channel is soloed because of its Solo Safe status, its Solo switch flashes.

Monitor Bus Operation

The Monitor bus outputs signal to both the near-field monitor output (on the FOH Rack) and headphone output (on the front of the D-Show Main Unit). The Monitor bus outputs can also be routed to D-Show hardware outputs and to bus-fed plug-ins.

Monitor Bus Switching

The following signals can feed the Monitor bus, listed below in order of priority: Key Listen, Solo bus, 2-Track return, and the Main mix.

Dynamics Key Listen

Pressing the Key Listen switch in the ACS section sends the key signal from the targeted channel’s built-in dynamics processor to the Monitor bus.

Key Listen temporarily overrides the currently enabled Solo bus operation (PFL or AFL), and replaces any other signal on the Monitor bus with the mono key signal.

AFL/PFL Solo Bus

In AFL or PFL mode, signal from any soloed channels is sent to the Monitor bus. When any channel is soloed, the Solo bus overrides the 2-Track return if it is enabled, or the Main mix if it is currently being sent to the monitors.

2-Track Return

If 2-Track input is enabled, any signal from those inputs is sent to the Monitor bus. The 2-Track return overrides the Main mix if it is currently being sent to the monitors.

Main Mix

The Main mix (the signal present on the Main busses) can be sent to the Monitor bus.

Assignable Monitor Output

The Monitor bus can be routed to hardware outputs and to bus-fed plug-ins.

▲ *These feeds are in addition to the existing, dedicated Monitor outputs on the FOH Rack, and are taken post-Monitor Speakers control and post-Monitor bus Delay.*

Hardware Outputs For routing to hardware outputs, the Monitor (Solo) bus outputs are available in the Mains tab of the Patchbay Outputs page. Monitor bus outputs are assignable to any number of physical outputs on the Stage Rack or FOH Rack in addition to the dedicated Monitor outputs on the FOH Rack. Use this capability to route monitor outputs to multiple cue stations (in-ear mix and wedge mix), or to an outboard analyzer.

Bus-Fed Plug-Ins For routing to bus-fed plug-ins, the Monitor bus appears as a choice in the plug-in routing selector. This lets you route the Monitor bus to a bus-fed stereo plug-in such as an onboard analyzer. Plug-ins can not be inserted on the Monitor bus.

Routing the Monitor Bus to Additional Outputs

To route the Monitor bus to additional outputs:

- 1 Go to the Outputs page and click the Mains tab.
- 2 Click in the grid to assign the Monitor output to the desired destination.

 *Solo In Place, when engaged, is simultaneously routed to the Mains and Monitor busses.*

Routing the Monitor Bus to Plug-Ins

To route Monitor output to a bus-fed plug-in:

- 1 Go to the Plug-Ins screen.
- 2 Make sure the desired stereo plug-in is installed and assigned to a rack slot.

- 3 Click the Plug-In Input selector at the top of the corresponding rack slot, and choose Bus Outs > Mains > Monitor - stereo.



Assigning monitor output to a bus-fed plug-in

Sending the Main Mix to the Monitor Bus

Monitor Output from an L-C-R Main Mix

The stereo Mix to Monitors signal is derived from the L-C-R Main mix by adding a -3 dB signal from the Center channel to the Left and Right monitor channels.

Monitor Output from an L-R+M Main Mix

In a L-R+M Main mix, only the Left and Right channels are heard in the Solo bus.

To send the Main mix to the monitors:

- 1 Do one of the following:
 - Press the Mix to Monitors switch in the Mains section.
 - or –
 - Go to the Options > Busses tab and select the Mix to Monitors option.
- 2 Turn the Monitor Speakers knob or the Headphones knob to adjust the corresponding output level.

Adjusting Solo Bus Level

Solo bus monitoring levels are controlled by the Level Trim knob in the Solo/PFL section, and the on-screen Level Trim control. The trim amount is adjustable over a range of -20 dB to +20 dB.

To trim the Solo bus level:

- 1 Solo a channel or press a Key Listen switch.
- 2 Do one of the following:
 - Turn the Level Trim knob to control the amount of signal sent to the Monitor bus.
 - or –
 - Go to the Options > Busses tab and adjust the Level Trim setting in the Solo and Monitor Operations section.

Adjusting Monitoring Level

Output levels for the near-field monitors and the headphones are controlled by the corresponding volume knobs in the Monitoring section.

Adjusting Monitor Delay

You can apply an adjustable delay to the monitor outputs and headphone outputs to match the acoustic delay from the main speaker system.

To adjust monitor output delay from the control surface:

- 1 Press and hold the Delay switch.
- 2 Do one of the following:
 - Turn the Select encoder in the Snapshots & Options section to adjust the delay in fine mode.
 - or –
 - Press and turn the encoder to adjust the delay in coarse mode.

To adjust monitor output delay on-screen:

- 1 Go to the Options > Busses tab.
- 2 Adjust the Delay setting in the Solo and Monitor Operations section.

The delay value appears in the Snapshots & Options display.

Talkback, 2-Track and Oscillator Controls

You can route D-Show Talkback microphone input, Intercom microphone input, or 2-Track source input to any Input Channel or FX Return from the Patchbay.

In addition, you can route Talkback microphone input, 2-Track source input and built-in Oscillator output directly to any output busses from the D-show control surface.

You can also route any Output bus or Direct Output to the 2-Track output on the FOH rack.

Talkback, 2-Track and Oscillator States When Loading Shows

When you load a Show file, Talkback, 2-Track and Oscillator are controls are set to off (deactivated), regardless of their state when the Show was last saved.

Using Talkback

The Talkback input on the top panel of the D-Show Main Unit can accept signal from any dynamic or condenser microphone.

Routing Talkback Microphone Input

To route Talkback microphone input to any D-Show Input Channel or FX Return:

- 1 Go to the Patchbay and click the Inputs tab.

- 2 To the left of the channel grid, click the Channels tab or the FX Returns tab.

- 3 At the top of the channel grid, click the FOH tab.

- 4 Click in the channel grid to assign the “Talk” input source (at the top right of the grid) to an Input Channel or FX Return (listed on the left).



Routing Talkback input in the Patchbay

To route Talkback microphone input to any D-Show output bus:

- 1 Press the Talkback switch in the Talkback/Osc section of the Main Unit so that it is lit.
- 2 Press the Route to Selected switch. The switch flashes to indicate Route to Selected mode.
- 3 Press the Select switch on each of the output busses (Auxes, Groups, PQs, Matrixes, or Mains) where you want to route Talkback signal. The Select switches flash to indicate Talkback assignment.
- 4 Press the flashing Route to Selected switch to confirm the assignment, or press the Cancel switch to cancel the assignment.

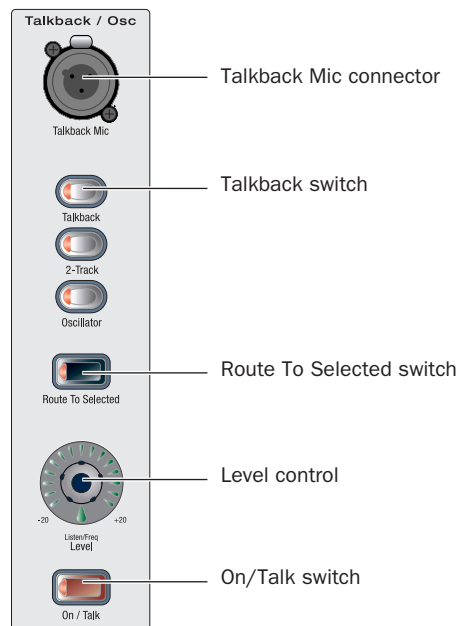

Talkback controls in the Talkback/Osc section of the Main Unit

Activating Talkback Input and Setting Level

To activate and set the level for Talkback input:

- 1 Press the Talkback switch in the Talkback/Osc section so that it is lit.
- 2 Activate Talkback by doing one of the following:
 - Press the On/Talk switch in the Talkback/Osc section.
 - Press the Talkback switch to the left of the Trackball.
 - Click the on-screen “In” button in the Talkback section of the Options > Misc page.
- 3 Set the Talkback input level by doing one of the following:
 - Turn the Level knob in the Talkback/Osc section.
 - or –
 - Drag the on-screen Level knob in the Talkback section of the Options > Misc page.

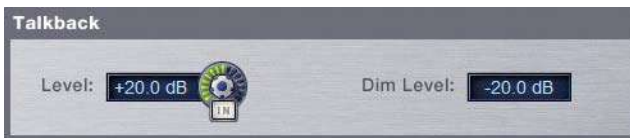

Talkback controls in the Options > Misc page

Setting Talkback Dim Level

When a Talkback signal is sent to an Output bus, the gain on the corresponding bus is automatically reduced by the amount specified in the Dim Level setting.

To set the Talkback Dim Level:

- 1 Go to the Options page and click the Misc tab.
- 2 In the Talkback section, double-click the Dim Level text box and enter a Dim Level value in the range –60 dB (maximum gain reduction) to 0 dB (no gain reduction).



Setting Talkback Dim Level in the Options > Misc page

Using the Intercom (“Com”)

The Intercom (“Com”) input on the back panel of the FOH Rack can accept input from any compatible dynamic or condenser microphone.

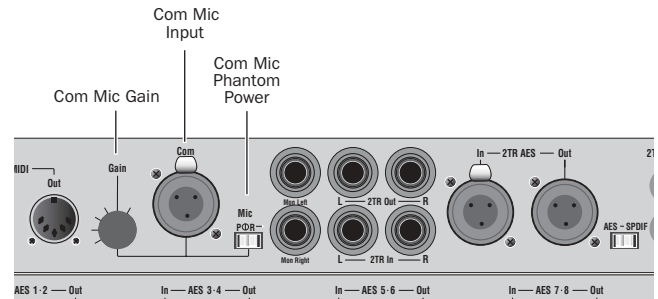

Intercom controls on the rear panel of the FOH Rack

When activated, the Intercom signal is mixed into the Monitor bus after the source selectors in the Solo/PFL selection, so is audible no matter what source (AFL/PFL, 2-Track, or Main Mix) is sent to the Monitor bus.

The Intercom signal can also be routed to any D-Show Input Channel or FX Return.

Routing Intercom Input

To route Intercom input to any Input Channel or FX Return:

- 1 Go to the Patchbay and click the Inputs tab.
- 2 To the left of the channel grid, click the Channels tab or the FX Returns tab.
- 3 At the top of the channel grid, click the FOH tab.
- 4 Click in the channel grid to assign the “Com” input source (at the top right of the grid) to an Input Channel or FX Return (listed on the left).



Routing Intercom input in the Patchbay

Activating Intercom Input

To activate the Com input so it is mixed with the Monitor bus:

- 1 Route the Intercom input as described in the previous section (“Routing Intercom Input” on page 115).
- 2 Press the Talkback button in the Talkback/Osc section and press the Level encoder to turn COM on/off (its LED ring lights).

Activating Phantom Power for Intercom Input

The “Com” input on the back panel of the FOH Rack has available 15V phantom power for using a condenser microphone.

To apply phantom power to the Intercom microphone:

- On the back panel of the FOH Rack, move the Com Mic Phantom Power switch to the right.

To set the Intercom microphone input level:

- On the back panel of the FOH Rack, turn the Com Mic Gain knob.

Using 2-Track Inputs and Outputs

Analog and Digital 2-Track Inputs and Outputs are available on the rear panel of the FOH Rack.

Routing 2-Track Input

To route the 2-Track inputs to any D-Show Input Channel or FX Return:

- 1 Go to the Patchbay and click the Inputs tab.
- 2 To the left of the channel grid, click the Channels tab or the FX Returns tab.
- 3 At the top of the channel grid, click the FOH tab.
- 4 Click in the channel grid to assign any of the following 2-Track input sources (listed at the top right of the grid) to an Input Channel or FX Return (listed on the left):
 - AL (Analog Left)
 - AR (Analog Right)
 - DL (Digital Left)
 - DR (Digital Right)



Routing 2-Track input in the Patchbay

To route the 2-Track inputs to any D-Show output bus:

- 1 Go to the Options page and click the Misc tab.
- 2 In the 2-Track section, select “Analog 2-Track” or “Digital 2-Track” to set the input source for the Output busses.



2-Track input source selector in the Options > Misc page

- 3 Press the 2-Track switch in the Talkback/Osc section of the Main Unit so that it is lit.
- 4 Press the Route to Selected switch. The switch flashes to indicate Route to Selected mode.
- 5 Press the Select switch on each of the output channels (Auxes, Groups, PQs, Matrixes, or Mains) where you want to route 2-Track signal. The Select switches flash to indicate 2-Track assignment.
- 6 Press the flashing Route to Selected switch to confirm the assignment, or press the Cancel switch to cancel the assignment.

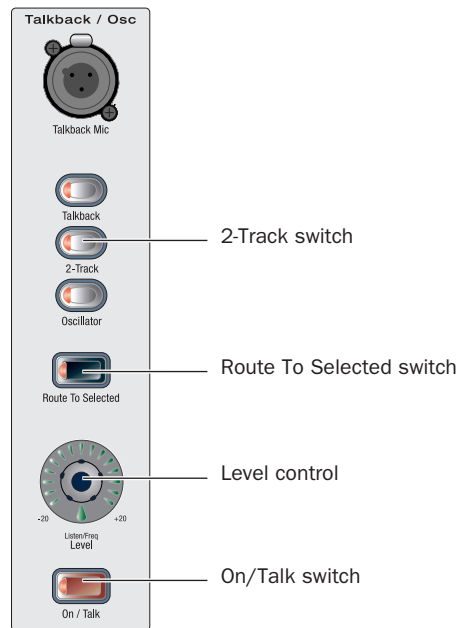

2-Track controls in the Talkback/Osc section of the Main Unit

Activating 2-Track Input and Setting Level

To activate and set the general level for 2-Track Input:

- 1 Press the 2-Track switch in the Talkback/Osc section so that it is lit.
- 2 Activate 2-Track input by doing one of the following:
 - Press the On/Talk switch in the Talkback/Osc section.
 - or –
 - Click the on-screen “In” button in the 2-Track section of the Options > Misc page.
- 3 Set the 2-Track input level by doing one of the following:
 - Turn the Level knob in the Talkback/Osc section.
 - or –
 - Drag the on-screen Level knob in the 2-Track section of the Options > Misc page.



2-Track controls in the Options > Misc page

Routing 2-Track Output

You can route any output bus or Direct Output to the 2-Track output on the FOH rack.

To route any D-Show Output bus to the 2-Track outputs:

- 1 Go to the Patchbay and click the Outputs tab.
- 2 To the left of the channel grid, click the tab for an Output bus (Auxes, Groups, PQs, Matrixes, or Mains).
- 3 At the top of the channel grid, click the FOH tab.
- 4 Click in the channel grid to assign an Output bus (listed on the left) to any of the following 2-Track output sources (listed at the top right of the grid):
 - AL (Analog Left)
 - AR (Analog Right)
 - DL (Digital Left)
 - DR (Digital Right)

To route any D-Show Direct Output to the 2-Track outputs:

- 1 Go to the Patchbay and click the Directs tab.
- 2 To the left of the channel grid, click the tab for a channel source (Channels, FX Returns, or Outputs).
- 3 At the top of the channel grid, click the FOH tab.
- 4 Click in the channel grid to assign a channel source (listed on the left) to any of the following 2-Track output sources (listed at the top right of the grid):
 - AL (Analog Left)
 - AR (Analog Right)
 - DL (Digital Left)
 - DR (Digital Right)



Routing 2-Track output in the Patchbay

Previewing 2-Track Output on the Monitor Bus

You can route the 2-Track output signal directly to the Monitor bus. You do not have to have the “On/Talk” switch on for this routing to be active.

To preview 2-Track output on the Monitor bus:

- In the Talkback/Osc section, press the Level encoder. The encoder’s indicator LED lights when 2-Track routing is activated.

Routing Oscillator Output

The output of the D-Show internal oscillator can be routed to any of the output busses.

To route oscillator signal to any D-Show output bus:

- 1 Go to the Options page and click the Misc tab.
- 2 In the Oscillator section, select from the following signal types:
 - 100 Hz Sine
 - 1 kHz Sine
 - 10 kHz Sine
 - Variable Sine
 - Pink Noise
 - White Noise
- 3 If you select Variable Sine, you can set the sine wave frequency with the on-screen frequency control (directly to the right of the Variable Sine option).



Oscillator controls in the Options > Misc page

- 4 Press the Oscillator switch in the Talkback/Osc section of the Main Unit so that it is lit.
- 5 Press the Route to Selected switch. The switch flashes to indicate Route to Selected mode.
- 6 Press the Select switch on each of the output busses (Auxes, Groups, PQs, Matrixes, or Mains) where you want to route Oscillator signal. The Select switches flash to indicate Oscillator assignment.

- 7 Press the flashing Route to Selected switch to confirm the assignment, or press the Cancel switch to cancel the assignment.

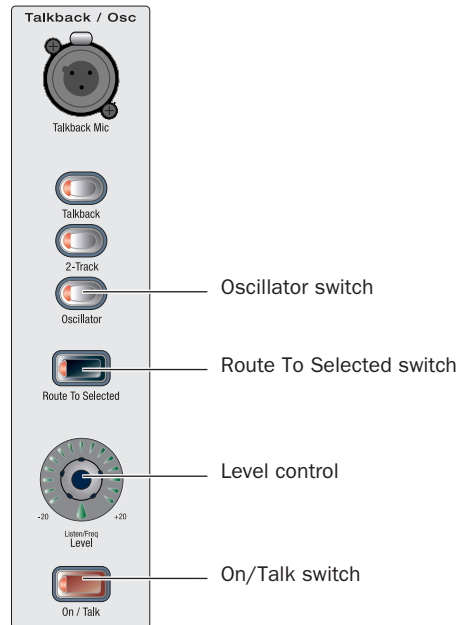

2-Track controls in the Talkback/Osc section of the Main Unit

Activating the Oscillator and Setting Level

To activate and set the level for the oscillator:

- 1 Press the Oscillator switch in the Talkback/Osc section so that it is lit.
- 2 Activate the oscillator by doing one of the following:
 - Press the On/Talk switch in the Talkback/Osc section.
 - or –
 - Click the on-screen “In” button in the Oscillator section of the Options > Misc page.
- 3 Set the oscillator level by doing one of the following:
 - Turn the Level knob in the Talkback/Osc section.
 - or –
 - Drag the on-screen Level knob in the Oscillator section of the Options > Misc page.

Chapter 15: Muting and Mute Groups

Muting

Channels can be muted in three ways: explicitly (lit solid), with the channel mute switch; implicitly (flashing), as a result of another channel being soloed, and as a member of a Mute Group or VCA (flashing).

Mute switches always behave in additive (latched) fashion. Channels can be muted in any sequence, and they will remain muted until they are unmuted.

Muting Input Channels and FX Returns

Channel mute is pre-fader on Input Channels and FX Returns.

To control the mute status of an Input Channel or FX Return:

- Press the Mute switch on the channel to toggle its mute status. The Mute switch lights solid to indicate the channel is explicitly muted.

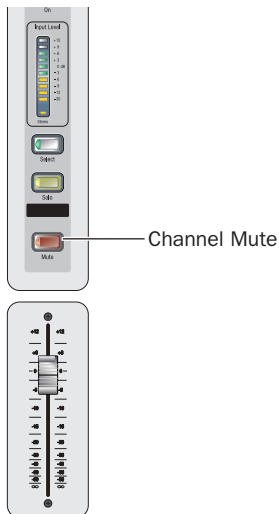

Channel Mute switch

Muting Output Busses

Mute operation is post-fader on all types of Output busses.

To control the mute status of an output bus:

1 Press one of the following switches in the Output Fader or Output Encoder assignment sections to assign control of the corresponding busses:

- Aux 1–8
- Aux 9–16
- Personal Qs (Assignable Output Faders only)
- Matrixes (Assignable Output Faders only)
- Groups

2 Press a Mute switch in the assigned section to toggle the mute status of the corresponding output bus.

Muting VCAs

When you mute a VCA, its member channels are muted. The member channel Mute switches flash to indicate they are muted as part of a VCA.

To mute the members of a VCA:

- Press the Mute switch on the VCA channel whose members you want to mute so that the Mute switch is lit.

Muting the Main Busses

The mute status of the Main busses is controlled from the Mute switch above the Mains Fader.

To control the mute status of the Main busses:

- 1 Press any combination of the Left, Right, or Center/Mono switches to assign control of the corresponding busses to the Mains Fader.
- 2 Press the Mute switch in the Global Master section to toggle the mute status of the assigned busses.

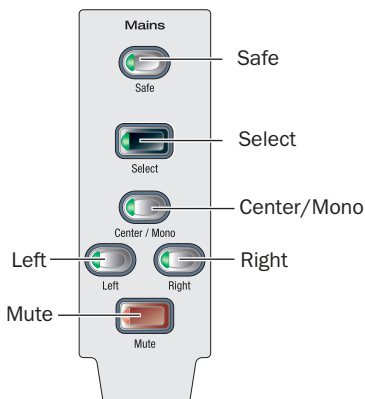

Main Bus controls and Mute switch

Flashing Mute Indication

A flashing Mute switch indicates the channel is implicitly muted as a result of a Solo or Mute Group activation.

Solo In Solo In Place mode, when a channel is soloed, all other channels that are not soloed or solo safe are implicitly muted.

Mute Group Members of a mute group are implicitly muted and flash when the mute group is active.

Mute Groups

D-Show lets you assign channels to any of 8 available Mute Groups. Mute Groups let you mute and unmute multiple channels simultaneously by pressing a single switch.

Any type of channel, including all Input Channels and all Output channels, except VCAs, can be assigned to Mute Groups.

Mute Groups only affect the status of channel Mute switches, and do not affect the on/off status of Aux Sends, output of the Talkback/Oscillator section, or the routing of signals to the monitor outputs.

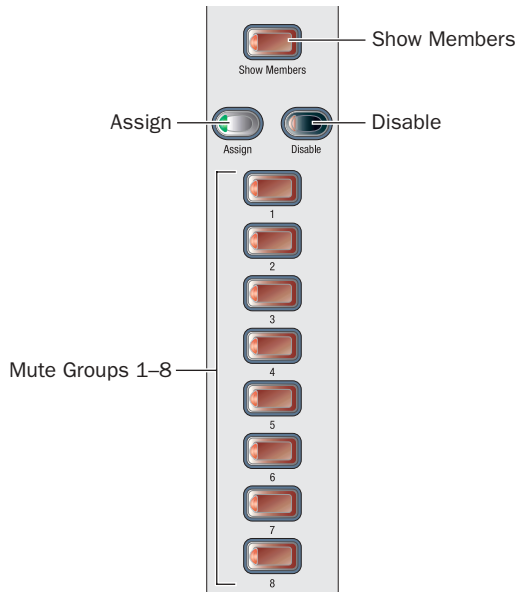

Mute Groups section

Defining Mute Groups

Mute Groups can be defined from the Mute Groups section on the control surface or from on-screen. Any mixture of channel types can be assigned to a Mute Group. Channels can be assigned to more than one Mute Group.

To assign channels or remove channels from a Mute Group:

- 1 Press the Assign switch in the Mute Groups section. The Assign switch flashes to indicate Assign mode.
- 2 Press the Mute Group switch (1-8) for the group where you want to assign or remove a channel. This switch flashes to indicate the group is targeted for assignment.
- 3 Press the Select switch for each channel you want to assign or remove from the Mute Group. The Select switches on the selected channels flash.
- 4 Do one of the following:
 - To confirm the Mute Group definition, press the flashing Assign switch or the flashing Mute Group switch.
 - or –
 - To cancel the Mute Group definition, press the Cancel switch in the Function section.

Viewing Members of Mute Groups

You can view Mute Group members in Input Channels and FX Returns

To view the members of Mute Groups in the Inputs section:

- Press the Show Members switch in the Mute Groups section.

The Bus Assign LEDs 1–8 at the top of each input channel strip flash in each channel to indicate membership in the corresponding Mute Group.

Activating Mute Groups

Mute Groups are activated from the Mute Groups section on the control surface.

To activate a Mute Group:

- Press a Mute Groups switch 1–8 to mute the members of the corresponding group. The Mute switches of the Mute Group members flash to indicate they are implicitly muted.

To activate multiple Mute Groups:

- Press any number of Mute Group switches 1–8 in any sequence. Mute Groups function in an additive fashion.

To deactivate a Mute Group:

- Press a lit Mute Group switch.

Mute Groups and Explicit Mutes

After activating a Mute Group, the explicit mute status of individual channels can be toggled by pressing their Mute switches at any time.

Any channels that are explicitly muted (before or after a Mute Group is activated) will remain muted when the Mute Group is deactivated.

Disabling Mute Groups

You can temporarily disable all Mute Group functions. When Mute Groups are disabled, all channels implicitly muted as a result of Mute Group activation are unmuted.

Channels can still be explicitly muted when Mute Groups are disabled. Mute Group assignments are preserved and made available again when Mute Groups are re-enabled.

To disable Mute Groups:

- Press the Disable switch in the Mute Groups section. The Disable switch flashes to indicated disabled state.

To re-enable Mute Groups:

- Press the flashing Disable switch in the Mute Groups section.

Part IV: Processing

Chapter 16: Dynamics

D-Show provides the following dynamics features:

- A built-in Compressor/Limiter and Expander/Gate is available on each Input Channel.
- Dynamics plug-ins can be used on input and output channels.
- All channels let you insert hardware dynamics processors.
- All built-in and most plug-in dynamic processors support side-chain keying with key filtering.

Built-In Dynamics

Each Input Channel provides a built-in Compressor/Limiter, and an Expander/Gate. Built-in dynamics are not limited by DSP resources, and can be configured as pre- or post the built-in EQ per channel.

Plug-Ins

Dynamics plug-ins can be used on input and output channels. When assigned in the plug-in racks, Dynamics plug-ins can be inserted on individual mono or stereo channels or fed by D-Show busses. Dynamics plug-ins can be adjusted using the dedicated Dynamics controls in the ACS, or from the on-screen Plug-Ins page. In addition, plug-in presets can be stored and loaded.

 *The Dynamics controls in the ACS provide a unified, consistent set of controls for both built-in and plug-in dynamics processing.*

Hardware Inserts

D-Show lets you insert a hardware dynamics processor and control its routing and in/out state. Routing must be performed on-screen. A dedicated In/Out switch for hardware inserts is provided in each input channel strip and in the ACS.

 See Chapter 18, “Hardware Inserts.”

Built-In Compressor/Limiter

One built-in Compressor/Limiter is available on each Input Channel. The Compressor/Limiter defaults to compression, or can be switched to a limiter by setting the Ratio to its maximum setting. Mono and stereo processing are supported.

Compressor/Limiter Parameters

Each Input Channel has controls for the following parameters:

Threshold Increases or decreases the threshold level for the built-in Compressor/Limiter. Threshold can be adjusted using Encoder 1 on the input channel strip, the ACS Threshold encoder, on-screen using the Comp/Lim Threshold encoder, or by dragging the Threshold handle in the on-screen Dynamics Graph display.

Ratio Increases or decreases the ratio for the built-in Compressor/Limiter. The most extreme clockwise setting (100:1) switches the process into Limiting mode. Ratio can be adjusted using the ACS Ratio encoder, the on-screen Comp/Lim Ratio encoder, or by dragging the Ratio handle in the on-screen Dynamics Graph display.

Attack Increases or decreases the attack time for the built-in Compressor/Limiter. Attack can be adjusted using the ACS Attack encoder or the on-screen Comp/Lim Attack encoder.

Comp Knee Increases or decreases the knee width for the built-in Compressor/Limiter. A knee value of 0 provides a hard knee setting; 100 provides a soft knee. Knee width can be adjusted using the ACS Comp Knee encoder or the on-screen Comp/Lim Knee encoder.

Release Increases or decreases the release time for the built-in Compressor/Limiter. Release can be adjusted using the ACS Release encoder or the on-screen Comp/Lim Release encoder.

Make-Up Gain Increases or decreases the make-up gain applied by the built-in Compressor/Limiter. Make-Up Gain can be adjusted using the ACS Comp Gain encoder or the on-screen Comp/Lim Gain encoder.

In/Out Takes the built-in Compressor/Limiter in or out of circuit (bypass). The Compressor/Limiter can be taken in or out of circuit using the Comp In/Out switch in the input fader strips, using the ACS Comp/Lim In switch, or by clicking the Comp/Lim button on-screen.

 *Dynamics plug-ins can be taken in/out of circuit from the Input Channel, the ACS, and software screen.*

Side-Chain Keying Provides side-chain and key listen. For details, see “Side-Chain Keys and Filters” on page 130.

Compressor/Limiter Gain Reduction Meters

Six-segment gain reduction meters for built-in dynamics are located in each input fader strip. These provide constant display of gain reduction on all currently banked Input Channels.

10-segment gain reduction meters are provided in the ACS for higher resolution metering of the currently selected channel or Dynamics plug-ins.

 *See Chapter 13, “Metering.”*

Compressor/Limiter Defaults and Ranges

The following table lists the default values and ranges for the built-in Compressor/Limiter:

Comp/Lim (defaults to Compressor mode)

Parameter	Default	Minimum	Maximum
Threshold	0 dB	-40 dB	+20 dB
Attack	10 ms	100 us	200 ms
Release	100 ms	10 ms	4 sec
Ratio	2:1	1.25:1	100:1
Knee	0 (hard)	0	100
Makeup Gain	0 dB	-40 dB	+20 dB

Built-In Expander/Gate

One built-in Expander/Gate is available on each Input Channel. The Expander/Gate defaults to expansion, or can be switched to a gate by setting the Ratio to its maximum setting. Mono and stereo processing are supported.

Expander/Gate Parameters

Each Input Channel has controls for the following parameters:

Threshold Increases or decreases the threshold level for the built-in Expander/Gate. Threshold can be adjusted using Encoder 1 on the input channel strip, the ACS Threshold encoder, on-screen using the Exp/Gate Threshold encoder, or by dragging the Threshold handle in the on-screen Dynamics Graph display.

Ratio Increases or decreases the ratio for the built-in Expander/Gate. The most extreme clockwise setting (100:1) switches the process into Gate mode. Ratio can be adjusted using the ACS Ratio encoder, the on-screen Exp/Gate Ratio encoder, or by dragging the Ratio handle in the on-screen Dynamics Graph display.

Attack Increases or decreases the attack time for the built-in Expander/Gate. Attack can be adjusted using the ACS Attack encoder or the on-screen Exp/Gate Attack encoder.

Gate Hold Increases or decreases the time the built-in gate holds. Gate hold can be adjusted using the ACS Comp Knee encoder or the on-screen Exp/Gate Hold encoder.

Release Increases or decreases the release time for the built-in Expander/Gate. Release can be adjusted using the ACS Release encoder or the on-screen Exp/Gate Release encoder.

Gate Range Increases or decreases the maximum range or depth of attenuation of the gate on that channel. Minimum gate depth is 0 dB. Gate Range can be adjusted using the ACS Gate Range encoder or the on-screen Exp/Gate Range encoder.

In/Out Takes the built-in Expander/Gate in or out of circuit (bypass). The Expander/Gate can be taken in or out of circuit using the Gate In/Out switch in the input fader strips, using the ACS Exp/Gate In switch, or by clicking the Exp/Gate button on-screen.

Side-Chain Keying The Expander/Gate supports side-chain and key listen. For details, see “Side-Chain Keys and Filters” on page 130.

Expander/Gate Gain Reduction Meters

Three-segment gain reduction meters for the built-in Expander/Gate are located in each input fader strip. These provide constant display of gain reduction on all currently banked Input Channels.

10-segment gain reduction meters are provided in the ACS for higher resolution metering of the Expander/Gate on the currently selected channel.

 *See Chapter 13, “Metering.”*

Expander/Gate Defaults and Ranges

The following table lists the default values for the Expander/Gate:

Exp/Gate Defaults (defaults to Gate mode)

Parameter	Default	Minimum	Maximum
Threshold	0 dB	-60 dB	+20 dB
Attack	1 ms	20 us	500 ms
Release	250 ms	10 ms	4 sec
Ratio	100:1 (Gate mode)	1.25:1	100:1
Gate Hold	100 ms	10 ms	4 sec
Gate Range	-20 dB	-80 dB	0 dB

Channel Modes Affecting Dynamics

The following features affect operation of built-in Dynamics.

Dyn Pre EQ

By default, built-in Dynamics processing occurs before built-in EQ processing in the signal chain of Input Channels. This can be changed on a per-channel basis by toggling the channel's Dyn Pre EQ setting.

To toggle the Dyn Pre EQ setting of an Input Channel:

- 1 Target the Input Channel whose Dyn Pre EQ mode you want to change by pressing its Select switch.
- 2 In the Channel Config section, press the Dyn Pre EQ switch. When enabled, the Dyn Pre EQ switch LED lights.

Input Direct Mode

Input Direct mode lets you completely bypass the built-in dynamics and EQ processing, and all inserts on Input Channels and FX Returns. For more information, see "Using Input Direct" on page 64.

Adjusting Dynamics

D-Show provides Dynamics controls in input channel strips, the ACS, and on-screen.

Input Fader Strip Dynamics Controls

All Input fader strips provide Threshold level controls, dedicated In/Out switches and gain reduction meters.

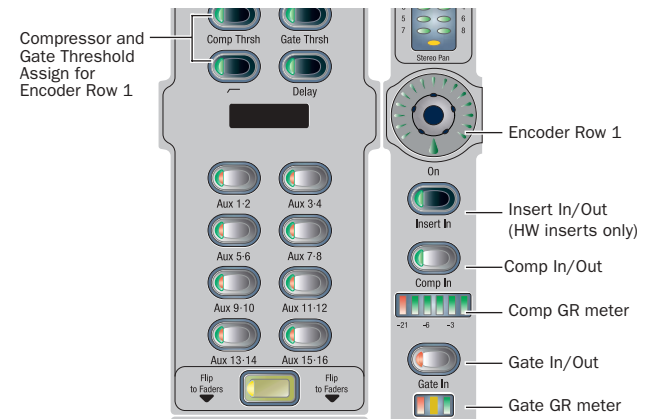

Dynamics controls and displays on input channels

To adjust Threshold from an input strip:

- 3 Press an Encoder 1 Assign switch (Comp/Lim, or Exp/Gate).
- 4 Rotate a channel Encoder 1 to adjust Threshold.

To take the process in/out of circuit:

- Press the Comp In or Gate In switch.

ACS Dynamics Section

The Dynamics controls in the ACS provide a unified, consistent set of controls for both built-in and plug-in dynamics processing for the targeted channel. Its six dual-purpose rotary/switch encoders, three In/Out switches, three Select switches, and dedicated high-resolution gain reduction meters provide a familiar way to adjust and view any type of Dynamics parameters and their settings.

All D-Show-compatible Dynamics plug-ins map their controls to the appropriate ACS encoders and switches.

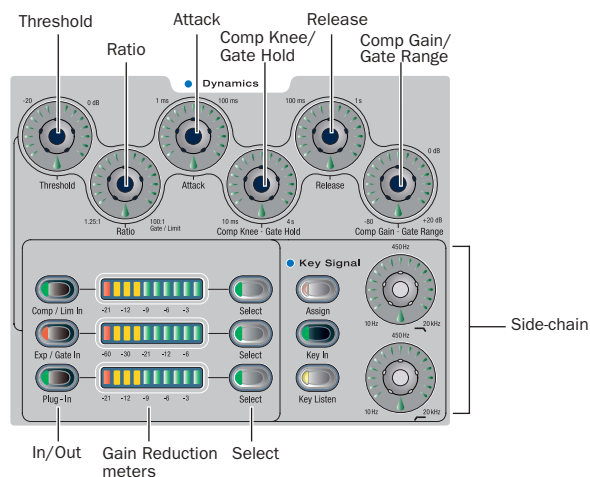

Dynamics controls in the ACS

To adjust Dynamics parameters from the ACS:

- 1 Target a channel by pressing its Select switch.
- 2 Press the Dynamics Select switch for the corresponding process:
 - For the built-in Compressor/Limiter, press the Comp/Lim Select switch.
 - For the built-in Expander/Gate, press the Exp/Gate Select switch.
 - For a Dynamics plug-in, press the Plug-In Select switch.
- 3 Adjust the appropriate Dynamics parameter. (See “Control Surface Encoders for Rotary and Switch Functions” on page 129.)

To take the process in/out of circuit:

- Press the appropriate In/Out switch in the ACS Dynamics section (Comp/Lim, Exp/Gate, or Plug-In).

To reset an entire Dynamics section to its default settings:

- Hold the Default switch while pressing the Comp/Lim or Exp/Gate Select switches in the ACS Dynamics section.

Software Screen Dynamics Controls

The software screen lets you adjust built-in or plug-in dynamics on-screen, with simultaneous access to Comp/Lim and Exp/Gate parameters (including their side-chain settings). The D-Show screen also provides the Dynamics Graph display. The Dynamics Graph displays a composite response of the compressor and gate that you can use to view and edit built-in Dynamics parameters.

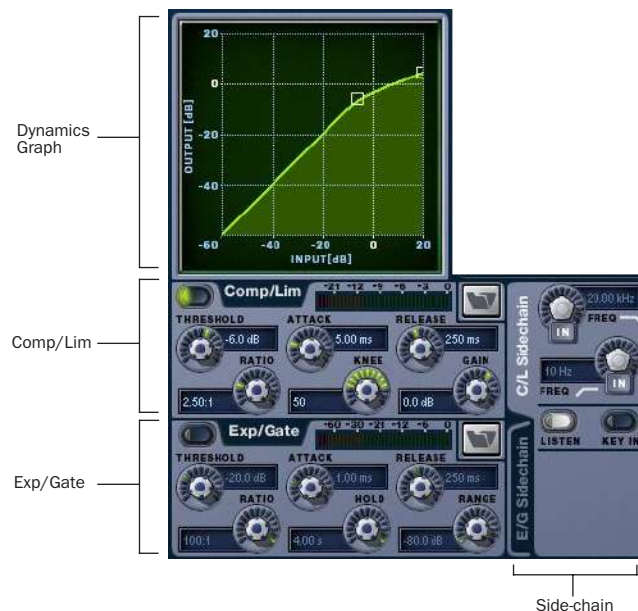

Dynamics controls in the software screen

To adjust Dynamics parameters on-screen:

- 1 Select a channel on-screen.
- 2 Adjust the on-screen controls as needed:
 - For the built-in comp/lim or exp/gate, adjust the parameter on-screen.
 - For plug-ins, click the Insert slot displaying the Dynamics plug-in to go to the Plug-Ins page.

See Chapter 19, “Plug-Ins.”

To reset an on-screen Dynamics parameter to its default value, do one of the following:

- Alt-click the control.
 - or –
- Right-click the control and choose Reset.

To reset an entire Dynamics section to its default settings:

- Right-click anywhere on the Compressor/Limiter or Expander/Gate sections (but not directly on an encoder or button) and choose Reset.

Using the Dynamics Graph Display

In addition to the on-screen encoders and buttons, you can adjust Dynamics parameters using the Dynamics Graph.

To adjust Dynamics parameters on-screen using the Graph display:

- 1 Select a channel on-screen.
- 2 Make sure the Compressor/Limiter or the Expander/Gate is in circuit, and targeted in the Dynamics Graph.

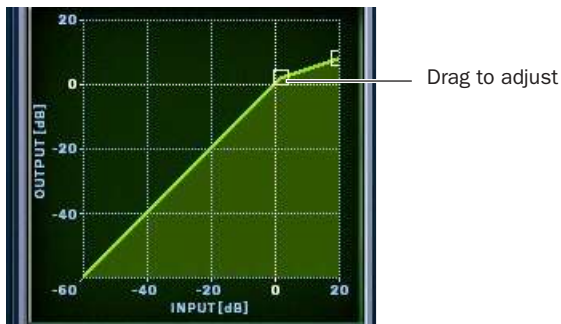

Dragging a handle in the Dynamics graph

 If the channel EQ is currently the target of the Dynamics Graph, click anywhere in the on-screen Compressor/Limiter or Expander/Gate sections to change the display.

- 3 Drag handles in the on-screen Dynamics Graph to adjust Threshold and Ratio.

 The Dynamics Graph does not support Fine adjust mode using the Fine switch.

Control Surface Encoders for Rotary and Switch Functions

D-Show encoders are dual-purpose controls that provide rotary and switch control of parameters, as follows:

- ◆ Rotating a dynamics encoder adjusts its assigned parameter (such as Threshold or Ratio).
- ◆ Pressing the encoder shaft switch toggles the state of an additional switched function.

Resetting (Default) and Fine Adjust for Dynamics Parameters

Dynamics parameters support D-Show Default and Fine Adjust modes using the control surface or the software screen.

 See Chapter 4, “Basic Commands and Modes.”

Plug-In Mapping of Dynamics Controls

D-Show-compatible Dynamics plug-ins map their primary controls to the corresponding controls in the ACS. (Dynamics controls in Input strips can only control built-in dynamics processors.)

 If more than one Dynamics plug-in is inserted on a channel, only the first Compressor/Limiter and the first Expander/Gate will map to the ACS. You can the Plug-In Rack to control any additional Dynamics plug-ins on the channel.

To adjust a Dynamics plug-in from the control surface:

- 1 Target the channel with the plug-in by pressing the channel Select switch.
- 2 Press the plug-in Select switch (located next to the ACS gain reduction meters in the Dynamics section).
- 3 Adjust plug-in parameters by pressing or turning the corresponding ACS Dynamics encoders.

When a plug-in provides more parameters than can map to the dedicated dynamics encoders, you can use the Assignable Output Encoders and the Previous/Next switches in the ACS to control the additional parameters.

 See Chapter 19, “Plug-Ins.”

Dynamics Settings and Presets

Built-in Dynamics settings can be copied and pasted between Input Channels. Settings can also be stored and loaded as D-Show Presets to archive and transfer settings.

Copying and Pasting Dynamics Settings

To copy and paste dynamics settings:

- 1 Right-click anywhere in the Comp/Lim or Exp/Gate areas of the on-screen Dynamics section and choose Copy Comp/Lim Settings, or Copy Exp/Gate Settings.



Copying dynamics settings

- 2 Go to the channel where you want to paste the settings.

3 Right-click in the Comp/Lim or Exp/Gate areas of the on-screen Dynamics section and choose Paste Comp/Lim Settings or Paste Exp/Gate Settings.

To copy and paste all of a channel's built-in Dynamics settings:

- 1 Right-click in the on-screen Dynamics Graph and choose Copy Dynamics Settings.
- 2 Select the Input Channel where you want to paste the settings.
- 3 Right-click in the on-screen Dynamics Graph of the new channel and choose Paste Dynamics Settings.

Presets for Built-In Dynamics

D-Show lets you store and load dynamics settings as presets for built-in and plug-in dynamics processors. Presets can be accessed from the control surface or on-screen.

To save or load a preset:

- 1 Adjust EQ settings on a channel (if saving a preset), or select an Input Channel or FX Return (to load a preset).
- 2 Click the EQ Presets icon on-screen. (The Presets icon is available in the Inputs screen Dynamics section.)



Built-in dynamics Presets buttons

3 If necessary, select the appropriate Presets folder by clicking and selecting it from the Folder selector.



Previewing a preset in the Presets window

4 Do one of the following:

- To preview an existing preset, click its name in the Presets window.
- To load the currently selected preset, press Enter or click the Close box (X) in the Presets window title bar.
- To save the current dynamics settings as a new preset, click New and enter a name for the preset file.
- To cancel without changing settings, click Cancel.

Side-Chain Keys and Filters

The built-in Compressor/Limiter and Expander/Gate support side-chain triggering.

Key In/Out

The Key In switch toggles the key signal in or out of circuit for the built-in Compressor/Limiter or Expander/Gate.

To toggle the side-chain key signal in or out of circuit, do one of the following:

- Press the Key In switch. When lit, the currently selected key signal is in circuit.
 - OR –
- Click the Key In button in the side-chain controls of the on-screen Dynamics section.

When the Compressor/Limiter key is in, it uses its own source channel (Self) as the key source signal.

When the Expander/Gate key is in, it can be self-keyed or use any other available D-Show channel.

Key Assign

The Key Assign switch in the ACS lets you select the side-chain source for a gate (compressors are always keyed by the channel signal). On-screen, the Key Source selector is provided in the Expander/Gate controls.

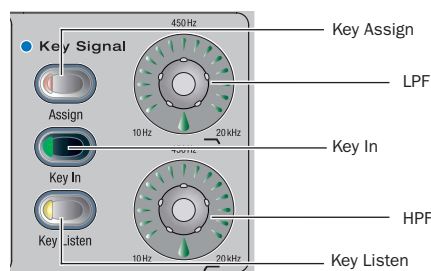

Side-Chain and Key controls in the ACS

Key Sources

The Compressor/Limiter can be self-keyed. The Expander/Gate can be self-keyed or use any available input, output, bus, or hardware channel as the key signal with a selectable source pickoff point.

You can use any of the following as the key source for the Expander/Gate:

- Self
- Any Input (Channel or FX Returns)
- Any Output (Auxes, Groups, Matrix, PQ, Mains)
- Any hardware input or output
- You can also specify the pickoff source for the key signal for input and output channels.

To select the key signal for the Gate on-screen:

- 1 Go to the Input Channel.
- 2 Click the E/G Side-Chain tab in the Dynamics section to select the gate.
- 3 Click the Key Source selector and choose an available channel or bus.



Choosing a Key Source

To select a pickoff point for the key source signal:

- Click the Source Pickoff selector and choose a pickoff source for the selected key signal:

Key Listen

The Key Listen switch toggles the key onto the Main Solo bus, replacing the signal there. This happens regardless of whether the key is the channel signal or the external key, or whether it has been side-chain filtered.

Key Listen always overrides the Solo bus. If soloed channels are already on the Solo bus, they are suppressed until Key Listen is cleared. If additional channels are soloed while Key Listen is on, they will be added but suppressed.

The Key Listen solo is also exclusive to itself. If one is active and you press Key Listen on a different processor or channel, the first Key Listen is turned off and the new Key Listen takes over.

⚠ Key Listen on a Dynamics plug-in does not route the signal to the solo bus, but to the plug-in output. Use caution when using the Key Listen with a plug-in dynamics processor.

To engage Key Listen:

- Press Key Listen.

To disengage Key Listen:

- Press Key Listen again. The Solo bus reverts to its previous signal (soloed channels, or none). You can also press Solo Clear once to turn off the any currently engaged Key Listen. Press Solo Clear a second time to clear channel solos, if any.

Side-Chain Filters

Both the Compressor/Limiter and the Expander/Gate side-chains provide two bands of EQ to band-limit the range of frequencies in the key signal.

To enable a side-chain EQ from the ACS:

- Press the LPF or HPF encoder.

To enable a side-chain filter on-screen:

- Click the side-chain filter In buttons on-screen.

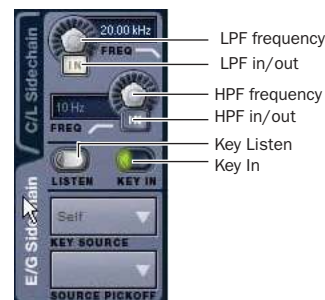

Side-Chain controls in the software screen (Expander/Gate shown)

To adjust a side-chain EQ:

- Turn the HPF or LPF encoder to adjust the frequency (each filter ranges from 10 Hz to 20 kHz). The LEDs around the encoder light, and the current frequency value is displayed on-screen.

Dynamics side-chain EQ defaults and ranges

Filter	Default	Minimum	Maximum
HPF	10 Hz, Off	10 Hz	20 kHz
LPF	20 Hz, Off	10 Hz	20 kHz

Side-Chain Limitations

Up to 32 side-chain Key signals can be routed from the following sources:

- Channel pre/post fader pickoff
- FX Return pre/post-fader pickoff
- Channel Insert return (when the channel does not have a hardware insert assigned).

There are no limits to the number of side-chain Key signals that can be routed from hardware inputs, Input Channel or FX Return top-of-channel pickoffs, or channel insert returns.

⚠ *Side-chain level may vary dramatically depending on where the Key signal is sourced. The top of channel pickoff can be as much as 18 dB louder than other pickoff points and sources.*

Chapter 17: EQ

D-Show provides the following EQ features:

- A built-in EQ is available on each Input Channel and FX Return.
- Graphic EQs are available for use on output channels.
- EQ plug-ins can be used on input and output channels.
- All channels let you insert hardware EQ processors.

Built-In EQ

D-Show provides different types of built-in EQ for Input Channels, FX Returns, and outputs.

Input Channels Each Input Channel provides a high-pass filter plus a built-in four-band parametric EQ. EQ can be set for digital or analog mode. In digital mode only, the four-band EQ provides selectable Bell/Shelf shapes for the Hi and Lo bands. Input Channel EQ can be configured as pre- or post-Dynamics on a per-channel basis.

FX Returns Each FX Return provides a built-in two-band EQ. FX Return EQ can be used in digital or analog mode; in digital mode, the bands can be individually configured for Bell or Shelf modes.

Output Busses Output busses can have a built-in Graphic EQ assigned to them.

Stereo EQs controls as mono EQ (in other words, both sides are linked). EQ settings are able to be stored and recalled through D-Show Snapshots and through D-Show presets.

Plug-Ins

EQ plug-ins can be used on input and output channels. When assigned in the plug-in racks, EQ plug-ins can be inserted on individual mono or stereo channels or fed by D-Show busses. EQ plug-ins can be adjusted using the dedicated EQ controls in the ACS, using the Assignable Output Encoders, or from the on-screen Plug-Ins page. In addition, plug-in presets can be saved and loaded.



The EQ controls in the ACS provide a unified, consistent set of controls for both built-in and plug-in EQ processing.

Hardware Inserts

D-Show lets you insert a hardware EQ processor and control its routing and in/out state. Routing must be performed on-screen. A dedicated In/Out switch for hardware inserts is provided in each input channel strip and in the ACS.

 See Chapter 18, “Hardware Inserts.”

Built-In EQ Parameters

HPF

Each Input Channel provides a fourth-order high-pass filter (HPF) with adjustable corner frequency and in/out control. The input HPF defaults to 20 Hz, out-of-circuit.

You can adjust HPF frequency and in/out state from each input strip, from the ACS, or on-screen.

Input Parametric EQ

Input Channels and FX Returns provide built-in parametric EQ. Input Channels provide four bands: Hi, Hi-Mid, Lo-Mid, and Lo. FX Returns provide two bands: Hi, and Lo.

Built-in EQ provides the following controls that affect all bands of EQ on the selected channels:

EQ In

EQ In toggles the built-in EQ processor (all bands) in or out of circuit on the selected channels. EQ In/Out can be controlled from each input fader strip, from the ACS, or on-screen.

Analog and Digital EQ Modes

The Analog/Digital button toggles the built-in parametric EQ between digital mode and analog mode, on a per-channel basis. Analog/digital mode switching is available on-screen.

Digital Mode A standard digital parametric EQ. Frequency range of 20 Hz to 20 kHz and gain range of 18 dB are available on all four bands. Digital Q is expressed in Q factor terms in the range 10 (left, a narrow band) to 0.1 (right, a wide band). Digital Mode is the default EQ mode.

Analog Mode An EQ with a response modeled on that of an analog console renowned for its EQ section. Frequency range is limited to match, and the outer bands provide shelving only. Analog Q is expressed in octaves of *bandwidth* in the range 0.1 (left, a tenth of an octave) to 2 (right, two octaves.)

 *The HPF does not change when the EQ is switched between Digital and Analog mode.*

Gain, Frequency, and Q/Bandwidth

Each band of built-in parametric EQ provides the following parameters, as available on Input Channels or FX Returns:

Gain Boosts or cuts the corresponding band. The LEDs around the Gain encoder light from the center-point to the right (boost), or from the center-point to the left (cut) to illustrate current Gain.

Freq Sets the center or corner frequency for each band, as follows:

- Freq sets the center frequency for the Hi-Mid and Lo-Mid bands, and for the Hi and Lo filters when in Bell mode.
- Freq sets the corner frequency for the Hi and Lo filters when in Shelf mode. (See “Bell and Shelf Modes for Hi and Lo Filters” on page 134.)

Turning the encoder clockwise increases the frequency for that band; turning it counter-clockwise decreases the frequency. A single LED around the encoder illustrates the current encoder setting. The available range of each band depends on the EQ mode (Digital or Analog). See “Control Ranges for Built-In Parametric EQ (All Modes)” on page 140.

Q (Q/Bandwidth) Controls Q (in digital mode) or bandwidth (analog mode).

- ◆ In Digital mode, Q determines Q factor. When the Hi or Lo filters are in Shelf mode, the Q knob determines the Q of the shelf.
- ◆ In Analog mode, this control changes to a bandwidth control which performs essentially the same function.

Band In/Out Each of the available EQ bands can be taken in or out (bypassed) using the band In/Out control. On the control surface, the Gain knob for each band serves as the in/out control by pushing the encoder. The indicator LED lights to indicate band In. On-screen, a dedicated In/Out switch is located just below each Gain knob.

Bell and Shelf Modes for Hi and Lo Filters

In digital EQ mode, the Hi and Lo filters on Input Channels and FX Returns can be toggled between Bell and Shelf modes.

When in Bell mode, the Hi or Lo filters function as a parametric EQ with variable Q. When in Shelf mode, the Hi module is a high-shelf EQ, and the Lo module is a low-shelf EQ. For instructions on configuring these bands for Bell or Shelf mode, see “Adjusting EQ” on page 135.

Channel Modes Affecting EQ

The following features affect operation of built-in EQ.

Dyn Pre EQ

By default, built-in Dynamics processing occurs before built-in EQ processing in the signal chain of Input Channels. This can be changed on a per-channel basis by toggling the channel’s Dyn Pre EQ setting.

To toggle the Dyn Pre EQ setting of an Input Channel:

- 1 Target the Input Channel whose Dyn Pre EQ mode you want to change by pressing its Select switch.
- 2 In the Channel Config section, press the Dyn Pre EQ switch. When enabled, the Dyn Pre EQ switch LED lights.

Input Direct Mode

Input Direct mode lets you bypass the built-in dynamics and EQ processing, and all inserts on Input Channels and FX Returns. For more information, see “Using Input Direct” on page 64.

Adjusting EQ

D-Show provides EQ controls in input fader strips, the ACS, and on-screen.

Input Fader Strip EQ Controls

Each input strip provides HPF and EQ In/Out controls.

- ◆ HPF can be adjusted on each Input Channel using the Encoder 1 HPF assignment switch and corresponding row of encoders.
- ◆ The EQ In switch takes the built-in parametric EQs in or out of circuit.

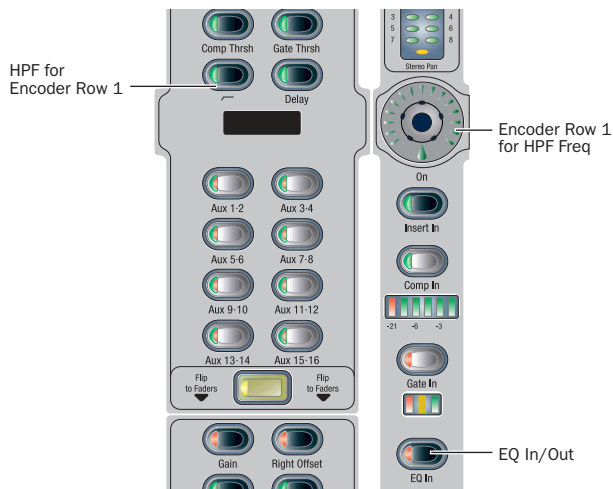

Dynamics controls and displays on Input Channels

To adjust HPF from an input strip:

- 1 Bank to the channel on the control surface.
- 2 Press the HPF Encoder 1 Assign switch.
- 3 Rotate the appropriate channel Encoder 1 to adjust HPF frequency. Press the appropriate encoder shaft switch to toggle HPF in or out.

💡 HPF can also be adjusted in the ACS or on-screen.

To bypass built-in parametric EQ (all bands) from an input strip:

- 1 Bank to the channel on the control surface.
- 2 Press the EQ In switch. When in circuit, the EQ In switch is lit. When built-in EQ is bypassed, the switch is unlit.

ACS EQ Controls

The EQ controls in the ACS provide a unified, consistent set of controls for both built-in and plug-in EQ processing for the targeted channel. One dual-purpose rotary/switch encoder controls the HPF. Twelve dual-purpose rotary/switch encoders control EQ parameters and their settings.

D-Show-compatible EQ plug-ins can map their controls to the ACS EQ section, and all plug-ins can be controlled using the Assignable Output Encoders.

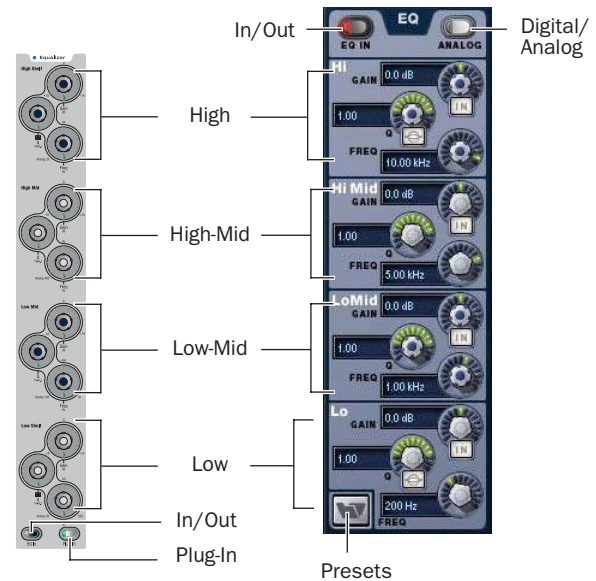

EQ controls in the ACS (left) and on-screen (right) for an Input Channel

FX Returns provide two bands of EQ (Hi and Lo) which can be toggled between Bell and Shelf modes.

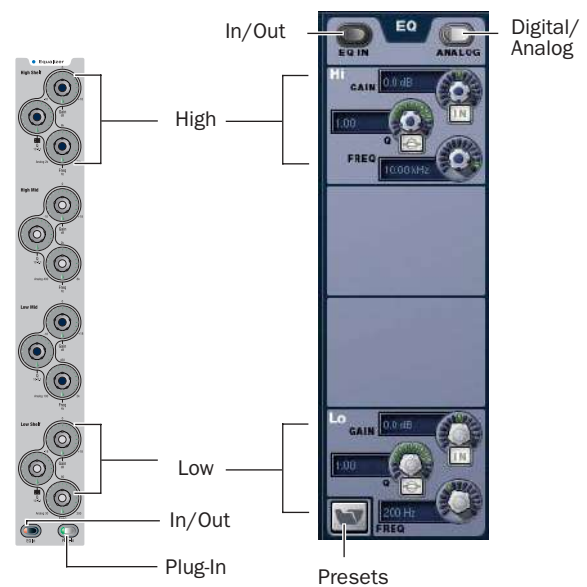

EQ controls in the ACS (left) and on-screen (right) for an FX Return

To adjust EQ parameters from the ACS:

- 1 Target a channel by pressing its Select switch.
- 2 Press the EQ In switch to enable built-in EQ on that channel. (The EQ In switch is provided in the ACS as well as in each input fader strip.)
- 3 Adjust the appropriate EQ encoder.

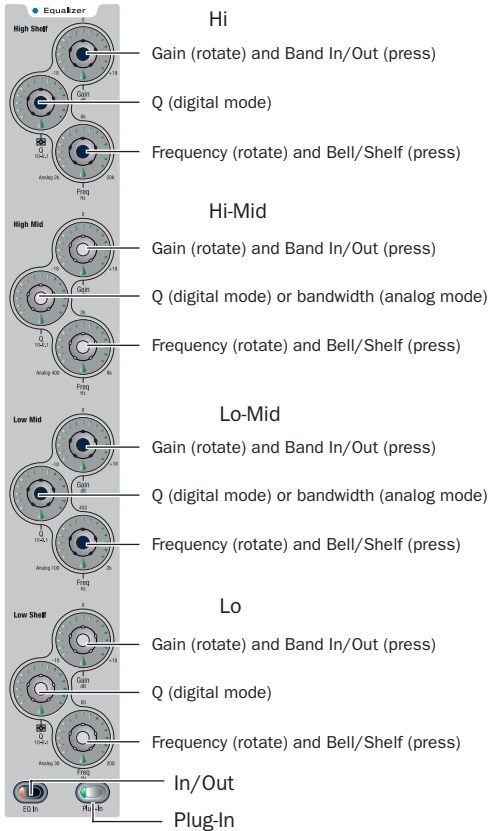

EQ controls in the ACS

To reset an EQ parameter to its default value:

- Hold the Default switch and adjust the control.

To reset the entire EQ section (all bands) on a channel:

- Hold the Default switch and press the EQ In switch.

Software Screen EQ Controls

You can adjust the built-in EQ using dedicated on-screen buttons for band in/out and bell/shelf toggling.

The D-Show software screen also provides the EQ Graph display to adjust frequency and gain simultaneously.

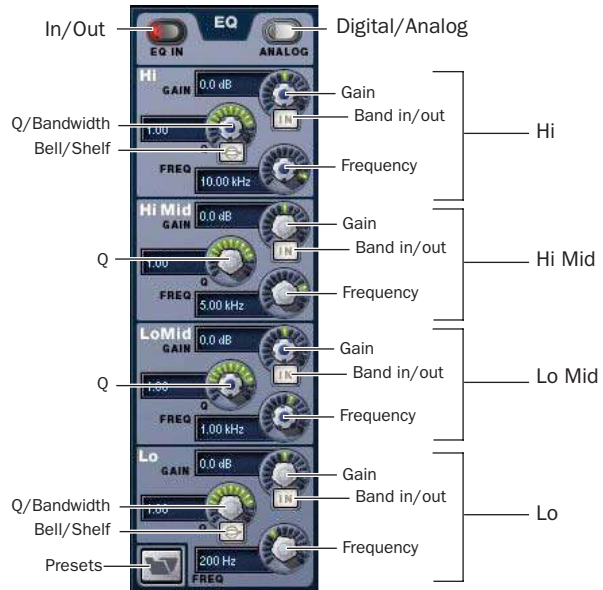

EQ controls in the software screen (4-band Input Channel EQ shown)

To adjust parametric EQ parameters on-screen:

- 1 Select a channel on-screen.
- 2 Click the EQ In switch to put the EQ in circuit.
- 3 Adjust the on-screen controls by doing one of the following:
 - Turn an on-screen knob (Gain, Q/Bandwidth, or Frequency) for each frequency band.
 - Click to toggle any on-screen EQ switch (EQ in/out, band in/out, or bell/shelf).
 - Click a displayed value and type a new value.
 - Drag up or down in a value display to increase or decrease the value.

To reset an on-screen EQ parameter to its default value, do one of the following:

- Alt-click the control.
 - or –
- Right-click the control and choose Reset.

To reset the entire EQ section (all bands) on a channel:

- Right-click anywhere in the EQ section on-screen (but not directly on an encoder or button) and choose Reset EQ Section.

Using the EQ Graph Display

The on-screen EQ graph lets you use the trackball to adjust frequency and gain for any available EQ band.



Dragging handles in the EQ graph display

To adjust EQ on-screen using the Graph display:

- 1 Select a channel on-screen.
- 2 Click the EQ In switch to put the EQ in circuit.
- 3 Drag the handles in the on-screen EQ graph display for each EQ band (Lo, Lo-Mid, Hi-Mid, or Hi), as follows:
 - Drag a handle right or left to increase or decrease frequency.
 - Drag a handle up or down to increase or decrease gain.

Graphic EQ for Outputs

A built-in 31-band Graphic EQ can be inserted on any of the following Output bus types: Mains, Groups, Auxes, Matrixes, and PQs. The Graphic EQ provides +/- 12 dB of gain and constant Q.

Assigning a Graphic EQ to a mono channel uses one available Graphic EQ. Assigning a Graphic EQ to a stereo channel uses two available Graphic EQs.

Graphic EQs can be adjusted on-screen, or using the eight faders on the Main Unit, which provide access to four banks of eight bands each.

Configuring Graphic EQs

To configure the number of Graphic EQs:

- 1 Put D-Show into Config mode.
- 2 Go to the Options page and click the System Config tab.
- 3 Click the Edit button on-screen.

- 4 Choose the number of Graphic EQs from the pop-up menu. You can choose to have 0, 8, 16, or 24 Graphic EQs.

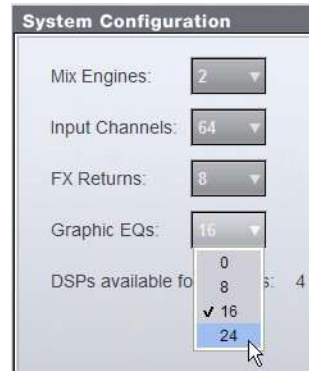

Configuring the number of Graphic EQs

Inserting Graphics EQs on Outputs

To insert a Graphic EQ on an Output bus:

- 1 Target the bus by pressing its Select switch.
- 2 In the Outputs page, click the Graphic EQ tab.
- 3 Click the Graphic EQ pop-up menu and choose an available mono or stereo Graphic EQ.



Assigning a graphic EQ (mono)

The 31-Band Graphic EQ appears on-screen.

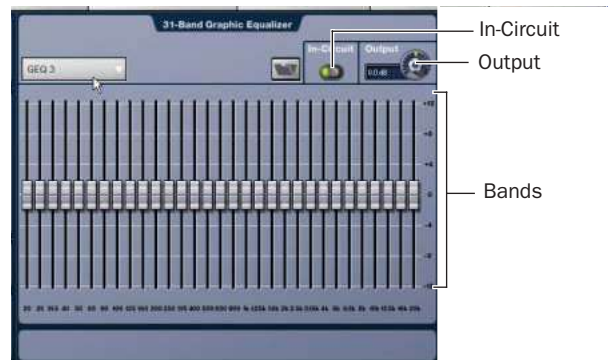

31-band graphic EQ

Graphic EQ Controls

The Input Faders of the Main Unit provide control of Graphic EQ in/out, and targeting of EQ bands. You can also use on-screen controls to adjust graphic EQ parameters.

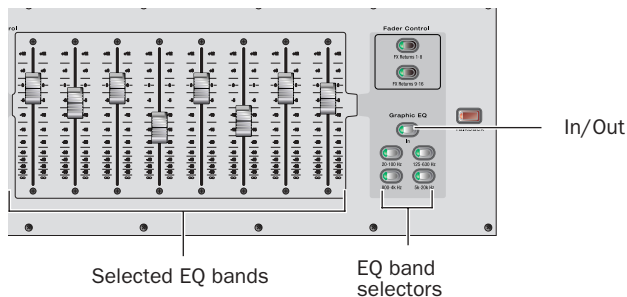

Graphic EQ controls on the control surface

To enable the graphic EQ:

- 1 Target an Output bus with a graphic EQ assigned. If no graphic EQ is assigned, display the 31-Band Graphic Equalizer tab in the Outputs page and assign one using the Graphic EQ pop-up menu.
- 2 Press the Graphic EQ In switch, or click the In button on-screen, to toggle in/out status. When enabled, the In/Out switch LED lights.

To set a graphic EQ curve:

- 1 Press the Graphic EQ band switch or click on-screen to select the appropriate bank of graphic EQ bands: (20 to 100 Hz, 125 to 630 Hz, 800 Hz to 4 kHz, or 5 kHz to 20 kHz).
- 2 Adjust one of the eight faders controlling the selected graphic EQ bands.
- 3 Press another Graphic EQ band switch or click on-screen to select another bank of graphic EQ bands and adjust as needed.

To adjust graphic EQ gain:

- Use the eighth fader in the fifth band (5 kHz to 20 kHz), or use the on-screen Output knob.

Resetting Graphic EQ Parameters

To reset a band to its default setting, do one of the following:

- Hold the Default switch and press the Select switch on the fader corresponding to the graphic EQ band.
- Right-click the individual band fader on-screen and choose Reset.
- Alt-click the band on-screen.

To reset the entire graphic EQ to flat:

- Right-click anywhere in the Graphic EQ section on-screen (but not directly on a fader) and choose Reset GEQ Section.

Plug-In Mapping of EQ Controls

D-Show compatible EQ plug-ins can map their gain, frequency, and Q/bandwidth controls to corresponding encoders on the control surface.

When a plug-in provides additional parameters beyond those that map to the dedicated EQ encoders, you can use the Assignable Output Encoders and the Previous/Next switches in the ACS.

 All plug-ins, including EQ plug-ins that do not map directly to dedicated D-Show EQ encoders, can be controlled using the Assignable Output Encoders.

To adjust an EQ plug-in from the control surface:

- 1 Target the channel with the plug-in by pressing the channel Select switch.
- 2 Press the plug-in Select switch (located at the bottom of the ACS EQ section).
- 3 Do one of the following:
 - If the EQ plug-in maps correctly, adjust parameters by pressing or turning the corresponding ACS EQ encoders.
 - or –
 - If the EQ plug-in does not map to the ACS controls, press the Insert Mode switch in the Insert Processing section of the ACS. Use the Assignable Output Encoders to adjust parameters, and use the Previous Page and Next Page switches to access other pages, bands and parameters.

 See Chapter 19, "Plug-Ins."

EQ Settings and Presets

Built-in parametric and graphic EQ settings can be copied and pasted between channels. EQ presets can also be saved and loaded to archive and transfer settings.

Copying and Pasting EQ Settings

To copy and paste an EQ setting:

1 Do one of the following:

- To copy a parametric EQ setting, right-click anywhere in the on-screen EQ section or EQ graph (but not directly on an encoder) and choose Copy EQ Settings.

– or –

- To copy a graphic EQ setting, right-click anywhere on the graphic EQ display (but not directly on a fader) and choose Copy GEQ Settings.



EQ Reset/Copy/Paste pop-up menu

2 Go to the channel where you want to paste the settings.

3 Do one of the following:

- To paste a parametric EQ setting, right-click in the new channel's EQ section or graph and choose Paste EQ Settings.

– or –

- To paste a Graphic EQ setting, right-click in the new channel's Graphic EQ section and choose Paste GEQ Settings.

Presets for Built-In and Graphic EQ

D-Show lets you store and load EQ settings to disk as Preset files. Presets can be used with built-in and plug-in EQ processors, including the graphic EQ. Preset files can be moved between systems and used for other Shows. Presets can be accessed from the control surface or on-screen.

To save or load a preset:

1 Adjust EQ parameters as needed.

2 Click the EQ Presets icon on-screen. (The Presets icon is available in the Inputs screen EQ section, and in the graphic EQ screen for an output channel).

3 Choose a Presets folder in the Folder display at the top of the Presets window. If necessary, choose the appropriate Presets folder by clicking and selecting it from the Folder pop-up menu.

 Check the Factory Presets folder for preconfigured settings.

 For information about creating and transferring folders and files, see Chapter 20, "Shows and File Management."



Presets window

Presets icon

EQ Presets window

4 Do any of the following:

- To preview an existing preset, click its name in the Presets window.
- To load the currently selected preset, press Enter or click the Close box in the Presets window title bar.
- To load a preset and close the Presets window, double-click the preset.
- To save the current EQ settings as a new preset, click New and enter a name for the preset file.
- To cancel without changing settings, click Cancel.

To save or load a preset for the Graphic EQ:

1 Go to the Outputs page for the channel on which the graphic EQ is assigned. If necessary, click the 31-Band Graphic Equalizer tab to display the graphic EQ on that channel.

2 Click the graphic EQ Presets icon (above the EQ bands, next to the In-Circuit button).

3 Choose a Presets folder in the Folder display at the top of the Presets window. If necessary, choose the appropriate Presets folder by clicking and selecting it from the Folder pop-up menu.

4 Do any of the following:

- To preview an existing preset, click its name in the Presets window.
- To load the currently selected preset, press Enter or click the Close box in the Presets window title bar.
- To load a preset and close the Presets window, double-click the preset.
- To save the current graphic EQ settings as a new preset, click New and enter a name for the preset file.
- To cancel without changing settings, click Cancel.

Control Ranges for Built-In Parametric EQ (All Modes)

Table 18. Control ranges for built-in parametric EQ

Band	Control	Range (Digital)	Defaults (Digital)	Range (Analog)	Defaults (Analog)
High (Bell/Shelf)	Frequency	20 Hz to 20 kHz	10 kHz	2 kHz to 20 kHz	6 kHz
	Gain	±18 dB	0 dB	±15 dB	0 dB
	Q/Bandwidth	10 to 0.1	1.0	Shelf only	none
High-Mid	Frequency	20 Hz to 20 kHz	5 kHz	400 Hz to 8 kHz	2 kHz
	Gain	±18 dB	0 dB	±15 dB	0 dB
	Q/Bandwidth	10 to 0.1	1.0	0.1 to 2.0 octaves	0.2
Low-Mid	Frequency	20 Hz to 20 kHz	1 kHz	100 Hz to 2 kHz	450 Hz
	Gain	±18 dB	0 dB	±15 dB	0 dB
	Q/Bandwidth	10 to 0.1	1.0	0.1 to 2.0 octaves	0.2
Low (Bell/Shelf)	Frequency	20 Hz to 20 kHz	200 Hz	30 Hz to 200 Hz	80 Hz
	Gain	±18 dB	0 dB	±15 dB	0 dB
	Q/Bandwidth	10 to 0.5	1.0	Shelf only	none

Main Unit Fader Banks and Graphic EQ Frequency Bands

Main Unit Fader Banks and Graphic EQ Frequency Bands

Main Unit Fader Number	17	18	19	20	21	22	23	24
Bank 1	20 Hz	25 Hz	31.5 Hz	40 Hz	50 Hz	63 Hz	80 Hz	100 Hz
Bank 2	125 Hz	160 Hz	200 Hz	250 Hz	315 Hz	400 Hz	500 Hz	630 Hz
Bank 3	800 Hz	1000 Hz	1.25 kHz	1.6 kHz	2 kHz	2.5 kHz	3.15 kHz	4 kHz
Bank 4	5 kHz	6.3 kHz	8 kHz	10 kHz	12.5 kHz	16 kHz	20 kHz	Output Level

Chapter 18: Hardware Inserts

D-Show lets you route signal to and from external devices as hardware inserts. Hardware inserts may be used on Input Channels, FX Returns, Groups, Auxes, Matrixes, Personal Qs, and the Main busses.

Up to 16 analog and 8 digital hardware inserts may be used at one time, depending on the I/O configuration of the FOH Rack.

Connecting External Effects Units

Outboard gear is made available to the system by connecting its inputs and outputs to connectors on the FOH Rack. The gear is then inserted in the signal path using on-screen controls.

To connect outboard gear for use as a hardware insert:

- 1 Connect the external device inputs to appropriate analog or digital output connectors (Analog 1–16 or AES 1–8) on the rear panel of the FOH Rack.
- 2 Connect the external device outputs to the corresponding input connectors on the rear panel of the FOH Rack (for example, signal taken from FOH Output 1 returns to FOH Input 1).

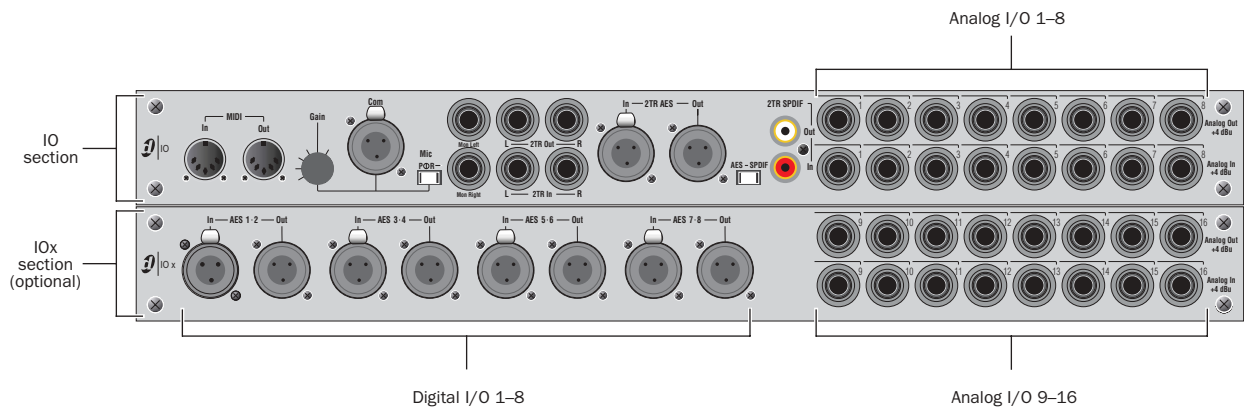

Figure 9. Hardware insert patch points on FOH Rack, showing standard IO connectors (top) and optional IOx connectors (bottom)

Assigning Hardware Inserts to Channels

You can assign hardware inserts directly from the Inputs page or Outputs page. You can also make hardware insert assignments from the Patchbay.

See Chapter 12, "Patchbay."

To assign a hardware insert to a channel or bus:

- 1 Go to the Inputs or the Outputs page and target the channel where you want to assign the hardware insert by pressing the channel Select switch.
- 2 In the Inserts section, do one of the following:
 - Click the Hardware Insert pop-up menu and choose an insert destination directly from the menu.
 - or –
 - Click the Hardware Insert button to go to the Inserts page of the Patchbay, and assign the insert from the Patchbay.



Assigning a hardware insert in the Outputs page

The name of the hardware insert destination appears in the on-screen Hardware Insert button.

Setting the Hardware Insert Location

You can choose the location of the hardware insert in the signal path, relative to the four plug-in inserts, for each channel. A hardware insert does not need to be currently assigned to do this.

To set the hardware insert location:

- 1 Go to the Outputs page and select the channel where you want to set the hardware insert location.
- 2 In the Inserts section of the Outputs page, click the hardware insert indicator so that it lights red.

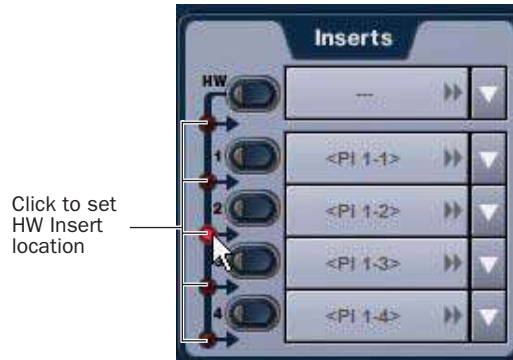

Setting a hardware insert location in the Inputs page

Activating and Bypassing Hardware Inserts

The available controls for activating and bypassing hardware inserts depend on the type of channel.

Inputs Channel and FX Returns On Input Channels and FX Returns, hardware inserts can be activated and bypassed directly from the channel strip or from the ACS section.

Outputs On Main busses and Output busses, hardware inserts are activated and bypassed from the ACS section only.

To activate or bypass a hardware insert from an Input Channel or FX Return:

- Press the Insert In switch on the channel. The switch lights when the insert is activated.

To activate or bypass a hardware insert from the ACS section:

- 1 Target the channel where you want to activate or bypass the insert by pressing the channel Select switch.
- 2 Press the Hardware switch to activate or bypass the hardware insert. The switch lights when the insert is activated.

Assigning Hardware Inserts from the Patchbay

To assign a hardware insert from the Patchbay:

- 1 Go to the Patchbay and click the Inserts tab.
- 2 In the Inserts page of the Patchbay, click Channels, FX Returns, or Outputs tab.
- 3 Click in the channel grid to assign the insert input/output number (listed across the top) to the channel where you want to assign the insert (listed on the left).



Assigning a hardware insert in the Patchbay Inserts page

The Patchbay Inserts page shows the name of the channel and its destination at the current cursor location. The Insert location is also displayed in the Inserts section in the Inputs or Outputs page.

Chapter 19: Plug-Ins

This chapter explains how to configure plug-ins before a performance, and how to use plug-ins during a performance. Plug-Ins can be inserted on all channels and bus outputs, or used as bus processors for effects such as reverb and delay.

 For complete information on D-Show compatible plug-ins, visit the Digidesign Web site (www.digidesign.com).

Plug-Ins Quick Start

Before a performance, enable Config mode and do any of the following:

- Install plug-ins (see “Installing and Authorizing Plug-Ins” on page 145).
- Assign plug-ins to racks and rack slots (see “Plug-In Racks” on page 149).
- Assign plug-in input and output routing, including side-chain routing (see “Assigning and Routing Plug-Ins” on page 152).
- View and adjust plug-ins using the control surface or software screen (see “Adjusting Plug-Ins” on page 155).
- Save and load plug-in settings as Presets, or with D-Show snapshots (see “Plug-In Presets and Snapshots” on page 157).

During a performance, do all of the following:

- Enable Show mode to “safe” (lock out) plug-in rack assignments and other plug-in rack operations that could interrupt a performance.
- Patch channels and busses to available plug-ins, re-assign plug-in routing, or re-assign existing side-chain routing.
- Adjust plug-in parameters from the ACS, Assignable Output Encoders, or on-screen.
- Save and load plug-in settings as Presets, or within D-Show snapshots.

Using Config and Show Modes for Plug-Ins

The current Console mode status (Config or Show mode) determines which plug-in functions are available.

Config mode is required to install plug-ins, assign them to rack slots, and to establish side-chain routing. When in Show mode, any operations that might interrupt audio throughput are locked out and unavailable.

 *Plug-In actions that interrupt audio require Config mode. For more information, see “Config Mode and Show Mode” on page 34.*

Installing and Authorizing Plug-Ins

Plug-ins can be installed on D-Show systems but not on the Standalone software.

 *Because installing plug-ins can interrupt audio throughput, always install plug-ins before a performance.*

Installing Plug-Ins

To install a plug-in:

- 1 Put D-Show into Config mode.
- 2 If installing from a CD-ROM, insert the installer disc into the CD-ROM drive in the D-Show FOH Rack.
- 3 Go to the Options page and click the Plug-Ins tab. The following two lists are shown:

Plug-Ins to Install This list shows available plug-in installers. At the top of the list is the Device selector, which provides a pop-up menu of available media sources. Plug-In installers are stored on the user drive partition after plug-in installation, and appear as available items when Previous Installs is selected from the media source list. This lets you re-install plug-ins without the original CD-ROM or other media.

Installed Plug-Ins This list shows all plug-ins already installed on the system. The plug-ins shown in plain text are available to process audio. Plug-Ins listed in italics are disabled and unavailable (see “Enabling and Disabling Installed Plug-Ins” on page 148).

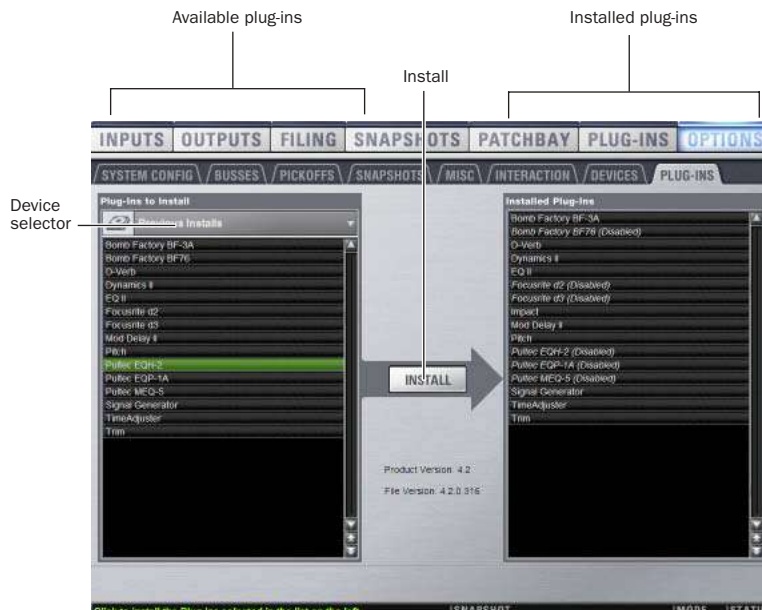

Figure 10. Options > Plug-Ins screen

4 Choose a device in the Device selector pop-up menu:

- Choose an external storage device to access plug-in installers on any inserted USB media.
- or –
- Choose CD-ROM to access a D-Show compatible plug-in installer loaded in the FOH Rack CD-ROM drive.

5 Select a plug-in from the Plug-Ins to Install list on the left by doing any of the following:

- Click to select a single installer.
- Shift-click to select multiple contiguous installers.
- Control-click to select or deselect installers one at a time. If a plug-in installer is not visible in any Device list, see “Installing Plug-Ins Manually” on page 147.

6 Click Install to install the selected plug-ins. Once installed, the plug-in appears in the Installed Plug-Ins list on the right.

Removing Plug-Ins

Uninstalling a plug-in removes the plug-in from the racks, but the installer remains in the Previous Installs cache and the list of installed plug-ins, making it easier to reinstall the plug-in at a later time without requiring the installer CD or other media. In order to completely remove and delete a plug-in and its installer, you must explicitly Delete the plug-in, as described in the following sections.

Installing, uninstalling, and deleting plug-ins are not supported using the Standalone software.

To uninstall a plug-in from the system but leave its installer available:

- 1 Put D-Show in Config mode.
- 2 Go to the Options page and click the Plug-Ins tab.
- 3 Right-click the specific plug-in name from the right-hand list and choose the Uninstall option for the selected plug-in.

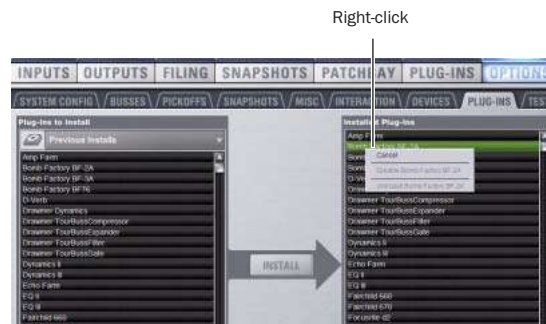

To reinstall a removed plug-in:

- 1 Put D-Show in Config mode.
- 2 Go to the Options page and click the Plug-Ins tab.
- 3 Select Previous Installs from the left-hand list.
- 4 Select the plug-in and choose Install. If the desired plug-in is not listed, it must be re-installed from the original CD-ROM or other media.

Deleting Uninstalled Plug-Ins

Once a plug-in is uninstalled, its installer can be deleted from the system. (Plug-ins which are currently installed cannot be deleted).

To completely remove a plug-in and its installer:

- 1 Put D-Show in Config mode.
- 2 Go to the Options page and click the Plug-Ins tab.
- 3 Select Previous Installs from the left-hand list.
- 4 Right-click the plug-in name and choose the Delete option for the selected plug-ins. The plug-in is removed from the system, and the stored plug-in installer is removed from the Previous Installs list.

Installing Plug-Ins Manually

If a plug-in does not appear in the Plug-Ins to Install list, it may not have a fully compatible D-Show installer and must be manually installed. This is required the first time you install the plug-in, and whenever you need to re-install a plug-in (such as after using the D-Show System Restore CD to update or reset the system).

 *A plug-in without a D-Show installer may still be compatible with D-Show. Consult the plug-in manufacturer for compatibility information.*

To install a plug-in manually:

- 1 Make sure all sound systems are shut down or muted.
- 2 Insert the plug-in installer disc into the CD-ROM drive on the FOH Rack.
- 3 Go to the Options page and click the System Config tab.
- 4 Hold the Ctrl key and click Shutdown Console on-screen. Follow on-screen directions to exit to the Desktop.
- 5 Copy the plug-in installer to the partition named User Data.
- 6 Launch the plug-in installer application and follow any on-screen directions. If prompted, do not restart the system from a plug-in installer. (Doing so will not harm the system, but will take longer, especially if you have multiple plug-ins to install manually.)
- 7 Quit the installer application and eject the installer disc.
- 8 Click the Return to D-Show shortcut on the desktop to re-launch D-Show.
- 9 Go to the Options page and click the Plug-Ins tab. Verify that the manually installed plug-in appears in the Console list of available plug-ins.

Authorizing Plug-Ins

After installing a plug-in, the system re-creates the list of available plug-ins. Whenever the racks initialize, the system checks authorizations for all installed plug-ins. If no previous authorization for a plug-in is recognized, you will be prompted to try a demo version, or authorize the full version of the plug-in.

D-Show supports challenge/response and iLok USB Smart Key authorization, including pre-authorized iLoks and iLok Authorization cards.

Challenge/Response Challenge/response authorization is only valid for the D-Show system the plug-in is currently installed on. Challenge/response codes can be communicated using any computer with Internet access.

 *It is not possible to connect D-Show to the internet directly.*

iLok USB Smart Key Plug-Ins supporting web authorizations through iLok.com can be authorized for your iLok Smart Key from any computer with Internet access. This lets you take your iLok and your plug-in authorizations anywhere, to use plug-ins installed on any system.

 *For more information on using iLoks, refer to the iLok Usage Guide on the Standalone Software CD or at the Digidesign Web site (www.digidesign.com).*

To authorize a plug-in:

1 When a plug-in authorization dialog appears, do one of the following:

- To try a demo of the plug-in, click Try.
- or –
- To have the system recognize the required authorization on your iLok, click Authorize. Insert your iLok Smart Key into any available USB port on D-Show when prompted.

 *Do not choose Internet Activation. Use Challenge/Response or an already authorized iLok USB Smart Key for plug-in authorization.*

2 Follow the instructions on-screen to complete the software authorization process.

USB Ports for iLoks

D-Show provides three USB ports on the control surface and two on the outside of the FOH Rack, any of which can be used to connect an iLok. Multiple iLoks can be connected at one time.

 Because the USB ports on the outside of the FOH Rack are the faster USB 2.0 version, it is recommended that you reserve one of them for large transfers to and from USB storage devices. (iLoks can still be used in this port with no affect on performance.)

In addition to these external USB ports, D-Show also provides a hidden, secure USB port inside the FOH Rack that can be used to attach and tie down an iLok for maximum protection.

To access the internal USB port and attach an iLok:

- 1 Remove the front panel of the FOH Rack.
- 2 Identify the USB port location at the lower left.
- 3 Insert the iLok and use a cable tie to secure the iLok to the interior support post.
- 4 Re-attach the front panel.

Enabling and Disabling Installed Plug-Ins

The Installed Plug-Ins list shows Disabled plug-ins in *italics*. Plug-Ins can be manually disabled and enabled to manage DSP resources, troubleshoot possible conflicts, and to manage plug-in availability.

To globally disable or enable a plug-in:

- 1 Click to select the plug-in name in the Installed Plug-Ins list, at the right of the Options > Plug-Ins screen.
- 2 Right-click the plug-in and select whether to disable or enable the selected plug-in.

If assigned to any rack slots, the plug-in will be displayed as unavailable and inactive.

Overview of Plug-Ins

The Plug-Ins screen displays the plug-in Racks, where the majority of plug-in set up features are located.

To access the Plug-Ins page:

- Press the Plug-Ins switch in the View Mode section of the ACS (or click the Plug-Ins tab). By default, the Plug-Ins page displays all four racks, which are empty until plug-ins have been assigned. (See also “Jump To” Plug-Ins” on page 156.)



Plug-In racks (no plug-ins assigned)

You populate the racks by *assigning* plug-ins in rack slots.

The following diagram shows an example of the racks with plug-ins assigned.



Plug-In racks with plug-ins assigned to rack slots

During a performance, plug-ins assigned in the racks can be inserted and routed on-screen and their parameters adjusted from the control surface or on-screen.

Plug-In Racks

The Plug-Ins page provides four plug-in racks. Each of the four racks has 25 slots into which you can load a plug-in. The four different racks can be viewed all at once, individually, and in varying zoom levels.



Figure 11. Plug-In racks and rack slots, Main view, with custom rack names shown.

Naming Plug-In Racks

By default, the racks are named Rack 1, Rack 2, Rack 3, and Rack 4. You can rename each rack as needed.

To rename a plug-in rack:

- 1 Double-click the rack name to highlight it on-screen.
- 2 Type a new name and press Enter. To return a rack to its default name, leave the name blank and press Enter.

 *Plug-Ins can be placed in any rack slot. Use the four different racks to organize processing functions such as Dynamics, Vocal FX, Reverb, or Group Inserts.*

Rack Views

The Plug-Ins page can be displayed in Full or Zoom views, with the option to display either view in Mini-view mode.

Full View

The default view of the rack screen is Full view, in which all four racks are shown (see Figure 11). This screen provides access to all rack slot controls and shows an icon representing each assigned plug-in. This lets you quickly see what plug-ins are available, and adjust their routing.

Zoom View (Plug-In View Mode)

In Zoom view, a single rack remains on-screen to the left, and the rest of the screen displays the targeted plug-in.



Zoom view, with a plug-in window open on-screen

To toggle Full or Zoom view modes, do one of the following:

- Press the Plug-Ins switch (in the View Modes section), or click the View toggle switch (upper right corner of the rack).

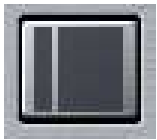

Zoom/Full view toggle

– or –

- Double-click a plug-in icon in any rack view to open that plug-in window in Zoom view.

 *D-Show provides other ways to jump to a plug-in view. For more information, see “Jump To” Plug-Ins on page 156.*

Mini-View Mode

Mini-view mode is an option available in Full and Zoom modes in which the rack slot displays are minimized and plug-in icons are hidden, to let you see more of the racks at one time. You can bypass, route, and work with plug-in snapshot controls in Mini-view mode.

To toggle mini-view on or off:

- 1 Click the Mini-view icon (upper left corner of the rack view).



Mini-view

Identifying Rack Slots

The racks indicate which plug-in is currently targeted by highlighting its rack slot controls in blue.

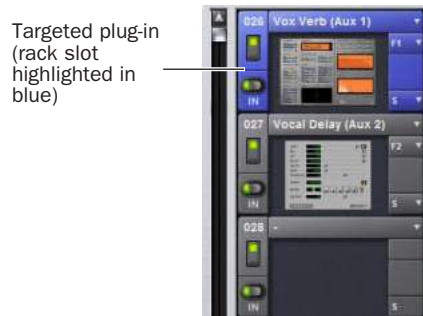

Highlighted rack slot indicating targeted plug-in

Within each rack slot, color outlines appear around each plug-in to indicate the type of plug-in currently targeted on the control surface. The following colors are used:

Outline Color Coding of Rack Slots

Color Outline	Indication
Yellow	A Dynamics plug-in, mapped to the ACS Dynamics section
Green	An EQ plug-in, mapped to the ACS EQ section
Red	The plug-in is mapped to more than one control surface section. For example, an EQ plug-in that is currently mapped to both the ACS EQ controls and the Assignable Output Encoders.
Blue	A plug-in mapped to the Assignable Output Encoders

Display of Unavailable or Inactive Plug-Ins

It is possible for a plug-in to be displayed in a rack slot but be unavailable for channel and bus processing. This can occur in any of the following circumstances:

- There are not enough DSP resources available for the plug-in.
- The assigned plug-in is part of the show file but is not installed on the current system.
- The plug-in has been disabled manually.

 *Place the cursor over the Tool Tips icon to see an explanation of why the plug-in is not available. To view DSP resource allocation, see “DSPs Available for Plug-Ins” on page 48.*

Unavailable Plug-Ins

When a plug-in cannot be used because of insufficient DSP resources, because it is disabled, or because it is not installed on the system, a warning icon is shown in front of the affected plug-in. The plug-in icon is greyed out, and the rack slot Power switch displays a yellow switch LED.



Unavailable plug-in

Indication of an unavailable plug-in

For more information, see “Installing and Authorizing Plug-Ins” on page 145.

Inactive Plug-Ins

When a plug-in has been manually made inactive, the plug-in icon is greyed out. Plug-Ins can be made inactive manually, letting you retain their assignment and settings in the rack while freeing up their DSP resources for other tasks.

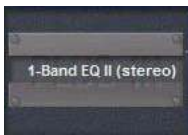

Indication of an inactive plug-in

For more information, see “Active and Inactive Plug-Ins” on page 153.

Rack Slots

Each rack provides 25 plug-in slots. You can assign any installed plug-in to any available rack slot.

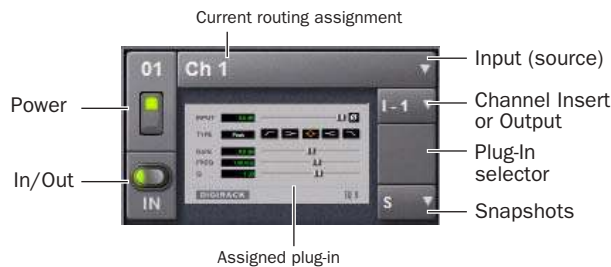

A rack slot and its controls, with an assigned plug-in shown

Each rack slot provides the following controls to select and manage plug-ins:

Power (Config Mode Only)

Power turns the rack slot on or off. When off, the plug-in consumes no DSP.

In/Out (bypass)

The In/Out switch takes the rack slot in or out of circuit (bypasses the slot and any plug-in assigned to it).

Input

The Input pop-up menu determines plug-in input (source). Use this menu to designate the plug-in as a channel insert or a bus processor by choosing from the Inserts or Bus sub-menus. For more information, see “Routing Plug-Ins” on page 153.

Once a plug-in has been routed, its input source is displayed in the Input area of each rack slot, as follows:

- If the plug-in is being used as an insert, the channel or bus name and number is shown, for example, *Kick (Ch 1)* or *Aux 1 (1–2)*. The Channel Insert/Bus Output selector automatically switches to Channel Insert mode, showing the insert point occupied by the plug-in.
- If the plug-in is on a bus, the selected bus source is shown in the Input selector, for example, *Aux 1* or *Grp 1*. The Channel Insert/Bus Output selector can be used to assign the output routing of the plug-in to a channel or bus.

Channel Insert or Bus Output

The Channel Insert/Bus Output pop-up menu displays different choices depending on whether the plug-in is being used as a channel insert, or as a bus processor, as follows:

- If the plug-in is being used as a channel insert, the Channel Insert selector shows the four insert points on that channel (1–4). The letter “I” is shown before the insert number (for example, I-1 indicates the current plug-in is inserted into the first insert position on its channel).
- If the plug-in is being used as a bus processor, the menu becomes the Output selector used to select the destination for plug-in output.



A mono plug-in inserted on a channel (at left) and a stereo plug-in assigned as a bus processor (at right)

Plug-In Selector

The Plug-In selector displays a list of available plug-ins to load into that rack slot. Plug-Ins are arranged by process type (such as EQ, Dynamics, and Delay). For more information, see “Assigning and Routing Plug-Ins” on page 152.

Snapshots Menu

The Snapshots menu provides tools to manage snapshot-related plug-in features from within the Plug-Ins screen. Using the Snapshots menu, you can quickly check to see which existing snapshots refer to the current plug-in, as well as create, update, or remove snapshots. For more information, see “Plug-In Presets and Snapshots” on page 157.

Side-Chain Selector

The Side-Chain selector appears near the top of the Rack view when you select a plug-in that supports side-chain or “key” input. In Config mode, the Side-Chain selector lets you establish a side-chain routing to the plug-in. Once established, you can route and re-route side-chain signals in both Config and Show mode. For more information about side-chain signals, see “Side-Chain Routing” on page 154.

Assigning and Routing Plug-Ins

Before a plug-in can be used to process audio, it must be assigned to a rack slot. Once assigned, you can use the plug-in as a channel insert or bus processor.

 Before a plug-in can be assigned, it must be installed. See “Installing and Authorizing Plug-Ins” on page 145.

Assigning Plug-Ins to Rack Slots

To assign a plug-in:

- 1 Put D-Show in to Config mode.
- 2 Go to the Plug-Ins page.
- 3 Click the Plug-In selector on an empty rack slot. (You can also use an already assigned rack slot to change a plug-in assignment.)
- 4 Choose an available plug-in from the Plug-In selector sub-menus. Only plug-ins that are installed will be available.



Plug-In selector menus

If the plug-in is not installed or there are insufficient DSP resources available, the plug-in will appear as unavailable, or inactive.

 Place the cursor over the plug-in to display a Tool Tip that explains why the plug-in is unavailable or inactive.

Plug-In Formats

Plug-Ins inserted on channels must be symmetrical (in other words, mono in/out or stereo in/out). Plug-Ins on busses can be asymmetrical (mono-in/stereo or multichannel out).

Mono Can be used as inserts only in mono strips or mono Auxes, mono Groups, or Matrix busses or on the C/M bus.

Stereo Can be used as inserts in stereo strips, stereo-linked Auxes, stereo Groups, PQ busses (which are always stereo) and across the L–R busses.

Other (Mono In/Stereo Out) Can be used on busses for delay, reverb, and similar processing.

Moving and Copying Plug-Ins

(Config Mode Only)

To move or copy a plug-in in the rack, drag the plug-in icon to a new rack slot. A pop-up menu appears offering three choices: “Cancel,” “Copy Plug-In Here,” or “Move Plug-In Here.”

Moving a Plug-In

When you move a plug-in from one rack slot to another, the plug-in type, in/out state, power on/off, current plug-in settings, and routing are maintained. In addition, all associated snapshots are updated to reflect the new rack position.

Copying a Plug-In

When you copy a plug-in to a new rack slot, the source plug-in type, in-circuit state, active state, and current plug-in settings are copied to the destination rack slot. However, the source plug-in routing is not copied. In addition, plug-in snapshots are not copied.

Overwriting An Existing Plug-In

When either moving or copying, if there is an existing plug-in in the destination rack slot, that plug-in is deleted. When the plug-in in the destination rack is deleted, any routing or references to the deleted plug-in in existing snapshots will be automatically cleared.

Active and Inactive Plug-Ins

To toggle the active/inactive state of a plug-in:

- Click the appropriate rack slot Power switch. When active, the Power switch is lit green. When a plug-in is unavailable (and inactive), the Power switch is lit yellow.



Indication of an inactive plug-in

Routing Plug-Ins

After a plug-in has been assigned to a rack slot, you can specify its routing. Plug-In routing determines whether the plug-in is used as a channel insert or as a bus processor.

Using Plug-Ins as Channel Inserts

Each D-Show channel provides four slots for channel inserts (as well as one hardware insert slot). Signal from the channel is routed to the insert and returned to the same channel.

You can assign plug-ins to specific channel insert points from the Plug-Ins screen or from the Input screen.

To insert a plug-in on a channel from the Inputs or Outputs page:

- 1 Go to the Input or Output screen.
- 2 Click the first available Channel Insert selector and choose an available plug-in from the rack sub-menus. All currently available plug-ins of a compatible mono/stereo format are listed in the sub-menus. Plug-Ins that are unavailable are listed in italics. Plug-Ins that are already assigned as channel inserts are shown with their insert assignment.

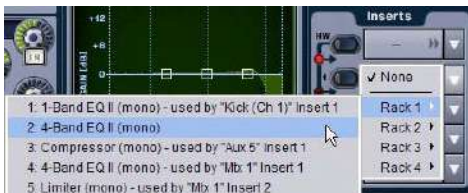

Inserting a plug-in on an input channel from the Inputs page

- 3 The selected plug-in appears in the Inserts list for that channel.



An assigned channel insert

- 4 To open the window for an inserted plug-in, click its name in the channel Inserts list.

To insert a plug-in on a channel from the Plug-Ins page:

- 1 Make sure the plug-in is already assigned to a rack slot. (For more information, see "Assigning and Routing Plug-Ins" on page 152.)
- 2 Click the Input (source) selector in the rack slot and choose a channel from its Inserts sub-menu.



Inserting a rack slot on a channel from the Plug-Ins page

The rack slot automatically identifies and connects to the first available insert slot (1–4) on the selected channel. The Channel Insert selector shows the current insert position.



Channel Insert selector for a plug-in rack

If no insert slots are available on the channel, the selector displays a question mark.

Using Plug-Ins as a Bus Processors

Plug-Ins can be used on busses for send-and-return processing with effects such as reverb and delay. A plug-in is configured for bus processing by assigning an Aux, Group, Matrix, PQ, or Main bus (including Monitor output) as the plug-in input source, then assigning the output of the plug-in to a D-Show Input Channel or FX Return, or to a hardware output, as follows:

- Return bus-fed plug-ins to an input or FX Return to establish an effects send-and-return path.
- Route bus-fed plug-ins to a hardware output for specialized processing needs (such as feeding an external crossover).

Input channel Direct Outs can also be routed to bus-fed plug-ins.

You assign plug-ins for bus processing from the Plug-Ins screen.

To use a plug-in as a bus processor:

- 1 Go to the Plug-Ins screen.
- 2 Make sure the plug-in is installed and assigned to a rack slot.
- 3 Click the Plug-In Input selector at the top of the corresponding rack slot, and choose an available D-Show bus from the Input sub-menus.



Assigning plug-in Input source to a Group bus

- 4 Click the Bus Output selector and choose an input, FX Return or hardware output.



Assigning plug-in output to an FX Return

Routing Channel Direct Outs to Plug-Ins

You can route the Input channel Direct Outs to plug-ins. This lets you directly feed plug-ins from individual channels to preserve Aux busses for other uses, with control over send level using the channel Direct Out level control.



Routing a channel Direct Out to a plug-in in the Plug-Ins page

When a channel Direct Out is routed to a plug-in, it follows the one global pickoff setting for that specific Direct Out (as set in the Patchbay), and is applied in addition to any other assignment made for that Direct Out. This makes it possible to use a channel's Direct Out to route that channel to both a Pro Tools recording option and to a plug-in. For more information, see "Direct Outputs and Routing in the Patchbay" on page 101.

⚠ If you do use a Direct Out to feed both a hardware output such as a Pro Tools recording option as well as a plug-in, be aware that any adjustments to that Direct Out affect both the output signal and the signal fed to the plug-in.

Side-Chain Routing

D-Show supports side-chain (key) processing for plug-ins that support side-chain triggering.

⚠ Side-chain routing is not stored in snapshots.

The Side-Chain selectors appear across the top of the plug-ins screen. You must be in Config mode to establish or remove a side-chain assignment. Once established, side-chain routing can be changed (but not added or removed) in Show mode.



Click to select Key (side-chain) source

Click to specify side-chain pickoff source

Side-Chain controls

To assign side-chain routing to a plug-in:

- 1 Select a plug-in that supports side-chain processing.
- 2 Put D-Show in to Config mode to display the Side-chain tools.
- 3 Choose the side-chain source signal from the Key Source pop-up menu.
- 4 Choose the pickoff point (tap) for the side-chain signal from the Source Pickoff pop-up menu.

Adjusting Plug-Ins

Plug-Ins can be adjusted from the control surface or on-screen.

Control Surface

The D-Show control surface provides plug-in controls in the ACS and Assignable Output Encoder sections for real-time interaction with plug-ins.

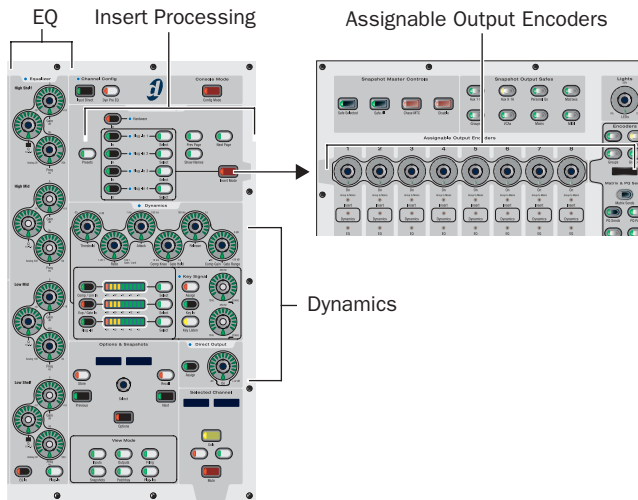

Plug-In controls on the control surface

The ACS provides the following types of control:

- ◆ The Assignable Output Encoders can be placed into Insert mode to adjust any selected plug-in.
- ◆ The Insert Processing section of the ACS provides switches to bypass, select, and target plug-ins inserted on the currently selected channel.
- ◆ EQ and Dynamics plug-ins can be selected and adjusted with the dedicated controls in the EQ and Dynamics sections in the ACS. EQ and Dynamics plug-ins can be targeted on the Assignable Output Encoders and ACS simultaneously.
- ◆ The Show Names and Previous/Next Page switches provide plug-in parameter display and navigation shortcuts.

To adjust a plug-in from the control surface:

- 1 Select the channel or bus on which the plug-in is inserted. To select a bus processing plug-in, bank to and select the FX Return or other channel assigned as the plug-in output.

 *The Source switch toggles channel displays to show the names of bus-fed plug-ins routed to a channel. Use the Source switch to quickly identify which FX Returns or other channels are being used as plug-in returns.*

- 2 In the Insert Processing section of the ACS, press the Select switch for the plug-in so that its switch is lit.
- 3 Press the Insert Mode switch, located between the Assignable Output Encoder row and the ACS. The first page of plug-in parameters is mapped to the eight Assignable Output Encoders.

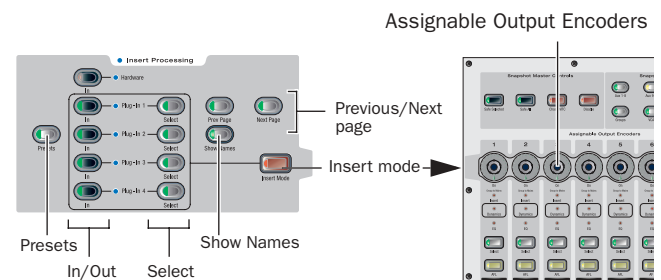

Inserts controls in the ACS

- 4 Rotate or press an Assignable Output Encoder (1–8) to adjust its mapped parameter, as follows:
 - To reset a parameter to its default value, hold the Default switch while rotating or pushing an encoder.
 - To adjust with greater resolution, hold Fine while rotating an encoder.
- 5 Press Show Names to cycle the encoder LCDs to display parameter names and values, as follows:
 - Pressing once shows the rotary parameter name.
 - Pressing again shows the rotary parameter value.
 - Pressing a third time shows the encoder switch parameter name.
 - Pressing a fourth time shows the encoder switch parameter value.

6 Press Previous Page or Next Page to bank to other plug-in parameters.

⚠ Some delay plug-ins include automatic beat clock and tempo controls (such as the Tempo Sync feature in the Digidesign Mod Delay plug-in). These types of plug-in controls default to On, or active. Be sure to manually deactivate Tempo Sync or the equivalent in these plug-ins.

Bypassing Plug-Ins

To bypass a plug-in:

- 1 Select the channel on which the plug-in is inserted.
- 2 In the Insert Processing section of the ACS, press the In/Out switch for the plug-in to toggle between in-circuit/out-of-circuit. When the switch LED is lit, it indicates that the plug-in is in-circuit. When unlit, the plug-in is out-of-circuit (bypassed).

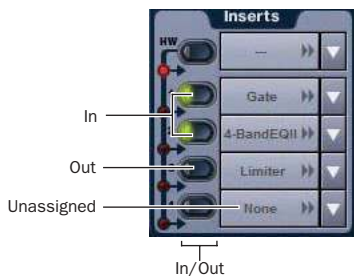

LED indication of in circuit and out of circuit (bypassed) inserts

Software Screen

The software screen can also be used to patch, route, or re-route plug-ins during a performance, even while in Show mode.

📖 Plug-Ins must already be installed on the D-Show system, and assigned to a rack slot, to be available while mixing. See "Assigning Plug-Ins to Rack Slots" on page 152.

"Jump To" Plug-Ins

The Input and Output screens let you "jump to" a specific plug-in insert to adjust it on-screen.

To jump to a plug-in insert from the Inputs or Outputs screen:

- 1 Select a channel to display it in the Inputs or Outputs screen.
- 2 Click the plug-in name shown in the channel Insert section.



Jumping to a plug-in on a channel insert

To jump to a plug-in on a bus:

- 1 Bank to the FX Return or other channel type assigned as the plug-in output, or bank to the output feeding the plug-in.
- 2 Select the channel to display it in the Inputs or Outputs screen.
- 3 Click the routing displayed beneath the Channel Name.

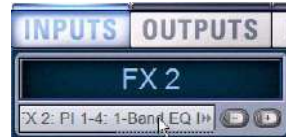

Jumping to a plug-in on an FX Return

Plug-Ins Screens and Channel Selection

When jumping to a plug-in, display depends on the type of plug-in routing, as follows:

Channel Inserts If the Plug-Ins screen is in Zoom view while you select a channel, the last selected plug-in for that channel is automatically selected and displayed in the Plug-Ins screen.

Bus-Fed Plug-Ins If no plug-ins are inserted on a channel (such as when returning a bus-fed plug-in to an FX Return) the plug-in feeding that FX Return is displayed.

Pinning a Plug-In View

It is possible to decouple the plug-in view from the console for consistent and constant access to a single plug-in on-screen, while still being able to select and adjust other plug-ins from the console. This capability is useful any time you want to always display an important plug-in (such as an analysis plug-in or primary EQ).

To pin a plug-in view:

- 1 Bring the desired plug-in into the main plug-in view (use the channel Select and Insert Mode switches, or double-click the desired plug-in in the rack).
- 2 Click the Push-Pin icon in the upper-right of the screen (the icon is located just to the left of the Presets and View Toggle icons).
 - When enabled, the Push-Pin icon appears lit. This indicates that the current plug-in will remain on-screen and will not lose focus, even if another channel is targeted.
 - When not enabled, the Push-Pin icon appears unlit. Plug-in view follows control surface selections.



Push-Pin plug-in view icon

Adjusting EQ and Dynamics Plug-Ins from the ACS

Many D-Show compatible EQ and Dynamics plug-ins map to the dedicated EQ and Dynamics controls in the ACS. Parameters map identically to those for the built-in EQ and dynamics, providing consistent location and control of these critical effects.

Plug-Ins that do not map to the ACS can be adjusted using the Assignable Output Encoders, as explained in “Adjusting Plug-Ins” on page 155.

Adjusting EQ Plug-Ins

To adjust an EQ plug-in using the ACS EQ section:

- 1 Target the channel with the plug-in by pressing the channel Select switch.
- 2 Press the plug-in Select switch (located at the bottom of the ACS EQ section).
- 3 Adjust plug-in parameters by pressing or turning the corresponding ACS EQ encoders.

Five-Band EQs

When a plug-in has more than four bands, some controls will be unavailable in the ACS EQ section. Use the Assignable Output Encoders to access and adjust additional controls.

When a plug-in contains more than one filter type for a particular band (for example, EQ II’s 1-band EQ with hi/lo pass, peak), pressing the Q encoder cycles through the various selections. The indicator LED only lights when a bell (peaking) filter type is selected.

Not all EQ plug-in parameters will map precisely to the values printed on the control surface.

 See Chapter 17, “EQ.”

Adjusting Dynamics Plug-Ins

To adjust a compressor, limiter, expander, or gate plug-in using the ACS Dynamics section:

- 1 Target the channel with the plug-in by pressing the channel Select switch.
- 2 Press the plug-in Select switch (located next to the ACS gain reduction meters in the Dynamics section).
- 3 Adjust plug-in parameters by pressing or turning the corresponding ACS Dynamics encoders.

When a plug-in provides additional parameters beyond those that map to the dedicated dynamics encoders, you can use the Assignable Output Encoders and the Previous Page/Next Page switches in the ACS (or on-screen).

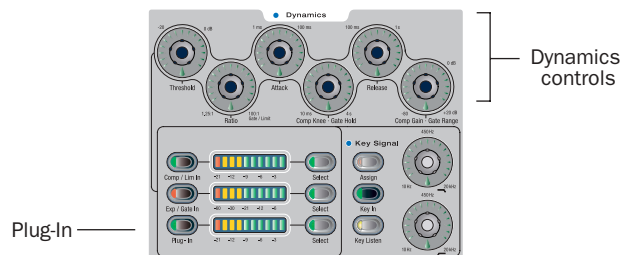

Controls for Dynamics plug-ins in the ACS

If more than one Dynamics plug-in is inserted on a channel, the lowest-numbered insert is mapped first to the Dynamics section. In some cases, this can be the same plug-in if the plug-in has both a Comp/Lim section and Exp/Gate section. When there is both a mappable compressor and gate, the Comp or Gate select button flashes to indicate whether a compressor or gate is currently controlled by the encoders. Press the Plug-In switch to toggle focus between the two dynamics inserts.

Not all Dynamics plug-in parameters will map precisely to the values printed on the control surface.

 For additional information about the dynamics controls in the ACS, see Chapter 16, “Dynamics.”

Plug-In Presets and Snapshots

D-Show lets you save and load plug-in Preset files to import, export, and transfer plug-in settings files.

Snapshots can also be used to automate changes to plug-in routing and settings.

 Presets can be applied to multiple Shows, while snapshots apply only to the Show file in which they are stored.

Presets

D-Show lets you save, load, and transfer plug-in Preset files. Presets are files that you can create to archive and transfer custom plug-in settings. You can then create your own Preset folders to organize Preset files. Preset folders and files can be transferred using the Filing Page.

To create a custom Presets folder:

- 1 Go to the Filing page and click the Transfer tab.
- 2 Click the Preset Folders icon.
- 3 Click the New button at the left of the screen.

4 Do one of the following:

- To leave the folder at its default name, press Enter.
- or –
- Type a new name and press Enter.

To save a Preset:

- 1 Adjust the plug-in parameters as desired.
- 2 Press the Presets switch in the ACS (to the left of the Insert 1–4 rows), or click the Presets icon in the Plug-Ins screen.
- 3 In the Presets window, click New.
- 4 Enter a custom name for the Preset.

To load a Preset into a plug-in:

- 1 Make sure the presets are already transferred and available on the current system. (Many plug-ins come with factory presets that will be installed along with the plug-in.)
- 2 Select the channel containing the plug-in.
- 3 Press Select in the Insert Processing section of the ACS to select the plug-in.
- 4 Press the Presets switch, to the left of the Insert 1–4 rows, or click the Presets icon in the Plug-Ins screen.
- 5 Do one of the following:
 - From the control surface, use the Presets and Snapshots displays and controls to scroll through, select, load, and save plug-in presets. Scrolling through the list using the ACS Select knob or Arrow keys automatically previews each preset.
 - or –
 - From the software screen, single-click a preset name in the Presets list to preview it. Click Cancel to close the Presets list without changing settings. To load a preset and close the Presets list, double-click a name in the Presets list.
- 6 Click Cancel at any time to close the Presets list and revert to the previous settings.

Snapshots

Snapshots can automate plug-in settings, including routing, and in/out state. (Side-chain routing is not supported in Snapshots.)

 *Snapshots do not store or recall Presets. Snapshots store plug-in settings as they were when the Snapshot was created or saved.*

Each rack slot in the Plug-Ins screen provides a Snapshot menu, with shortcuts for common snapshot-related tasks:

- Create a new snapshot
- Add a plug-ins to the MIDI/Plug-Ins list, and automatically re-scope the snapshot to include plug-ins.
- Remove a plug-in from a snapshot

Snapshots Containing this Plug-In Lists all currently loaded snapshots referencing the plug-in, in sequential order. Choose a snapshot to load it. (This menu option is useful for targeting snapshots while editing plug-in racks.)

Create New Snapshot Containing this Plug-In Adds a new snapshot to the snapshot list in which only plug-ins are scoped. This snapshot is inserted immediately after the currently targeted snapshot, which may not necessarily be the last snapshot. The snapshot is named to reflect the plug-in rack position, for example: “PI 1-1: Reverb One” is a Reverb One plug-in assigned to rack 1, slot 1.

Add (or Update) this Plug-In to Snapshot Adds a plug-in reference, with current settings, if the currently targeted snapshot does not already reference this plug-in. If the currently targeted snapshot already references this plug-in, the choice is Update (see next).

Update this Plug-In in Snapshot Updates snapshot with current settings, if the currently targeted snapshot already references this plug-in.

Remove this Plug-In in Snapshot Removes reference to this plug-in in the currently targeted snapshot.

 See Chapter 21, “Snapshots.”

Plug-Ins and D-Show Standalone Software

You can use D-Show Standalone software to preconfigure plug-in routing and in/out state, with the following limitations:

- Plug-Ins cannot be installed in the Standalone Software.
- A Show file must be transferred from a console on which plug-ins were previously installed.

Once a Show file containing plug-ins has been transferred to the standalone software, the following rules apply:

- Plug-Ins can be placed in racks and routed in Standalone mode.
- Snapshots can be created, loaded, and stored.
- Plug-In settings cannot be adjusted.
- Plug-In Presets cannot be saved or loaded.

Plug-In DSP Usage

Plug-Ins utilize DSP resources when they are assigned to a rack slot, and that rack slot is powered on. You can turn off unused plug-ins to reclaim their DSP by making them inactive, or by removing them from the system.

Plug-In availability is limited to the available DSP resources. Additional DSP can be added to D-Show by purchasing and installing Mix Engine cards.

The amount of DSP available for plug-ins also varies with the current system configuration settings for Input Channels, FX Returns, and graphic EQs. Higher number of Input Channels leave fewer DSP resources for plug-ins, as shown in the Options > System Config screen.

Initializing the Plug-In Racks

The racks are initialized (or re-initialized) whenever the system is first powered on, whenever the FOH Rack is restarted, after installing a plug-in, and after disabling or re-enabling a plug-in.

While the racks are initializing, they are offline and do not process audio. Avoid performing any Filing or Transfer functions until the racks are finished initializing. Rack status is displayed on-screen in the banner display.

Plug-In Levels

D-Show displays its levels in meters in dBVU, with 0 dBVU = -20dBFS.

Internally, D-Show provides up to 48-bit processing for built-in EQ and dynamics. Plug-Ins provide up to 24-bit processing, with level matching circuitry and logic ensuring maximum fidelity and sonic performance throughout the entire signal path. Due to variances in how plug-in metering is implemented by different manufacturers, performance may vary with regard to plug-in gain reduction meters and their relative levels.

When using side-chain routing, be aware of potential level differences between Input Channel pickoff points. For more information, see “Side-Chain Keys and Filters” on page 130.

Plug-In Latency and Processing Delay

Plug-In latency includes processing delay of the plug-in itself plus routing delay, as follows:

- Instance delay: (2 samples per plug-in)
- DSP chip delay (3 samples)

Viewing Plug-In Latency

Plug-In processing delay can be seen by right-clicking the plug-in icon in the rack. Use the number reported when calculating latency for manual delay compensation.

Examples

- ◆ If there is only one plug-in on a channel, the total delay will be the amount of plug-in latency + 2 + 3. (2 samples for the one plug-in instance, plus 3 samples for the DSP routing to the racks and back.)
- ◆ If you have two plug-ins on a channel or bus, the delay will be plug-in #1 latency + 2 + plug-in #2 latency + 2 + 3. If plug-in #1 has 12 samples of latency, and plug-in #2 has 15, total latency will be 34 samples (12 + 2 + 15 + 2 + 3).

Part V: Shows

Chapter 20: Shows and File Management

D-Show lets you store, recall and transfer D-Show system settings. There are three types of information files that can be managed separately, as follows:

Show Files These files are used to store, recall and transfer D-Show system settings and snapshots.

Preset Files These files are used to store settings for built-in processors and plug-ins, and Recall Safe Scope Sets.

Console Setting Files These files are used to transfer or back up the current state of the D-Show system.

! *D-Show does not need to be in Config mode to carry out file management tasks. However, many file management operations, including loading Shows, may interrupt audio throughput. Make sure to perform all file management tasks before a performance.*

Creating Shows

A Show file contains all console settings, including configuration, signal routing, mixer settings, plug-in information, snapshots, and other operational settings. Shows are grouped together in Show Folders.

Show Folders

Show Folders contain Show files. You can create and manage Show Folders from the Save tab of the Filing page.



Show Folders and Show files in the Save tab of the Filing page

Creating Show Folders

To create a new Show Folder:

- 1 Go to the Filing page and click the Save tab.
- 2 In the Show Folders column, click the New button.
- 3 Type a name for the Show Folder and press Enter.

Duplicating Show Folders

To duplicate a Show Folders:

- 1 In the Show Folders column, click a Show Folder name to select the folder.
- 2 Click the Duplicate button.

The folder and all of the Show files it contains are duplicated.

 You can also duplicate folders by right-clicking a Show Folder name and choosing Duplicate.

Renaming Show Folders

To rename a Show Folder:

- 1 In the Show Folders column, click a Show Folder name to select the folder.
- 2 Click the Rename button.

 You can also rename Show Folders by right-clicking a Show Folder name and choosing Rename, or by double-clicking a Show Folder name.

- 3 Type a new name for the Show Folder and press Enter.

Deleting Show Folders

When you delete a Show Folder, all Show files contained in that folder are also deleted.

To delete a Show Folder:

- 1 In the Show Folders column, click a Show Folder name to select the folder.
- 2 Click the Delete button.

 You can also right-click a Show Folder name and choose Delete to delete the folder.

Show Files

Creating and Saving Show Files

When you create a new Show file, it captures the current state of the D-Show system. Show files are automatically saved when they are created or overwritten.

To create a new Show file:

- 1 Go to the Filing page and click the Save tab.
- 2 In the Show Folders column, select the Show folder where you want to save the Show.
- 3 In the Shows column, click the New button. The new Show file captures the current state of the system.
- 4 Type a name for the Show file and press Enter.
- 5 Double-click in the Notes field for the Show and type any comments you want to save with the Show.

Information about the Show file is shown in the Info area of the Filing page.

 *Show files are automatically saved when they are created; no further action is required to save them.*

To update or overwrite an existing Show file:

- In the Shows column, right-click the Show file name you want to overwrite, and choose Overwrite from the pop-up menu. The current state of the system is saved to the selected Show file.



Right-clicking a Show file name in the Shows column

Duplicating Show Files

To duplicate a Show file:

- 1 In the Shows column, click a Show file name to select the file.
- 2 In the Shows column, click the Duplicate button.

 *You can also right-click a Show file name and choose Duplicate to duplicate the file.*

Renaming Show Files

To rename a Show file:

- 1 In the Shows column, click a Show file name to select the file.
- 2 In the Shows column, click the Rename button.

 *You can also right-click a Show file name and choose Rename, or double-click the Show file name to rename the file.*

- 3 Type a new name for the Show file and press Enter.

Deleting Show Files

To delete a Show file:

- 1 In the Shows column, click a Show file name to select the file.
- 2 In the Shows column, click the Delete button.

 *You can also right-click a Show file name and choose Delete to delete the file.*

Loading Shows

You can load Show files into the D-Show system from the Load tab of the Filing page.

Shows cannot be loaded onto the destination D-Show system directly from the portable storage device, but must first be transferred to the system before loading.

 *Loading a show automatically replaces the current console settings with those of the loaded show, and may interrupt audio throughput.*



Show Folders and Show files in the Load tab of the Filing Page

To load a Show file:

- 1 Go to the Filing page and click the Load tab.
- 2 In the Show Folders column, click a Show Folder name to select the folder. Any Show files in the folder are displayed in the Shows column.
- 3 In the Shows column, click a Show file name to select the file.
- 4 Click the Load button.

D-Show loads the new Show file, replacing the current system configuration, routing, and control settings with those contained in the new file.

System Configurations and Loading Shows

Show files include D-Show system configuration settings (such as number of Mix Engines; Number of Input Channels, FX Returns, and EQs; Aux and Group Bus configurations).

- If a Show file includes the same system configuration settings as the current configuration, the configuration information appears in blue text in the Info area.
- If a Show file differs from the current configuration, but can be loaded on the system, the relevant configuration changes appear in orange text in the Info area. When the Show file is loaded, D-Show restarts in the new configuration.
- If a Show file differs from the current configuration and cannot be loaded on the system in its entirety, the configuration information appears in red text in the Info area.

If a Show configuration is too large for the current system, mix elements are dropped in following order:

- 1 Plug-Ins are deactivated
- 2 Graphics EQs are dropped
- 3 Input Channels are dropped

Working with Presets

Presets are used to store, recall and transfer factory or user-defined presets. Preset files are grouped in the following types of Preset Folders:

- Built-in Compressor/Limiter, Expander/Gate, 4-band EQ, 2-band EQ, 31-band Graphic EQ
- Plug-ins
- Scope Sets

For more information on creating and loading presets, refer to Chapter 16, “Dynamics” Chapter 17, “EQ” and Chapter 19, “Plug-Ins.” For Scope Sets, see Chapter 21, “Snapshots.”

Preset Folders

Preset Folders contain Preset files. Each of the built-in D-Show processors (Compressor/Limiter, Expander/Gate, 4-band EQ, 31-band Graphic EQ) and each plug-in has its own Factory Defaults folder. Additional folders are provided for Scope Sets.

You can create additional Preset Folders for each processor or plug-in and store new Presets in them. These folders can then be transferred to a portable storage device for transfer to other D-Show systems.

Creating Preset Folders

To create a new Preset Folder:

- 1 Go to the Filing page and click the Transfer tab.
- 2 Click the Preset Folders icon. A list of Preset Folders appears in the left column.



Preset Folders icon in the Transfer tab of the Filing page

- 3 In the left column, click the New button.
- 4 Type a name for the Preset Folder and press Enter.

The new Preset Folder is available in the Preset window for each processor or plug-in.

Duplicating Preset Folders

To duplicate a Preset Folder:

- 1 In the left column, click a Preset Folder name to select the folder.
- 2 Click the Duplicate button.

The folder and all of the Preset files it contains are duplicated.

 You can also right-click a Preset Folder name and choose Duplicate to duplicate the folder.

Renaming Preset Folders

To rename a Preset Folder:

- 1 In the left column, click a Preset Folder name to select the folder.
- 2 Click the Rename button.

 You can also right-click a Preset Folder name and choose *Rename*, or double-click a Preset Folder name to rename the folder.

- 3 Type a new name for the Preset Folder and press Enter.

Deleting Preset Folders

When you delete a Preset Folder, all Presets contained in that folder are also deleted.

To delete a Preset Folder:

- 1 In the left column, click a Preset Folder name to select the folder.
- 2 Click the Delete button.

 You can also right-click a Preset Folder name and choose *Delete* to delete the folder.

Preset Files

You can manage Preset files from the Transfer tab of the Filing page. You cannot create Preset files from the Filing page. Preset files are created from the Presets window of the processor or plug-in; Scope Sets are created from the Scope Sets window of the Recall Safe page.

Duplicating Presets

To duplicate a Preset file:

- 1 Go to the Filing page and click the Transfer tab.
- 2 Click the Built-In or Plug-In icon and choose a processor or plug-in from the pop-up menu. The available Preset Folders for the processor or plug-in appear in a pop-up menu above the left column.



Built-In EQ in the Transfer tab of the Filing Page

- 3 Click the Preset Folder name and choose a Preset Folder from the pop-up menu. Any Presets in the folder appear in the left column.



Preset Folder names at the top of the Presets column

- 4 Click a Preset file name to select the file.
- 5 Click the Duplicate button.

 You can also right-click a Preset file name and choose *Duplicate* to duplicate the Preset.

Renaming Presets

To rename a Preset file:

- 1 In the left column, click a Preset file name to select the file.
- 2 Click the Rename button.

 You can also right-click a Preset file name and choose *Rename*, or double-click a Preset file name to rename the Preset.

- 3 Type a new name for the Preset file and press Enter.

Deleting Presets

To delete a Preset file:

- 1 In the left column, click a Preset file name to select the Preset.
- 2 Click the Delete button.

 You can also right-click a Preset file name and choose *Delete* to delete the Preset.

Transferring Settings, Shows and Presets

You can copy Console Settings, Shows, and Presets to and from a portable storage device (such as a USB key disk) for backup, transfer from standalone software, and transfer between D-Show systems.

Settings, Shows and Presets cannot be loaded onto the destination D-Show system directly from the portable storage device, but must first be transferred to the system before loading.

Transfer of Settings files, Show files, and Preset files is managed from the Transfer tab of the Filing page. The Transfer tab shows the D-Show system files in the left column and the contents of the portable storage device in the right column. Items are selected for transfer in the center.



File transfer controls

To transfer Settings, Shows or Presets between D-Show and a portable storage device:

- 1 Go to the Filing page and click the Transfer tab.
- 2 Connect a portable storage device (such as a USB key disk) to D-Show. The device appears above the right column.
- 3 Do one of the following to select the type of data to transfer:
 - To transfer all data, click the Console icon.
 - To transfer Console Settings, click the Settings icon.
 - To transfer Show Folders, click the Show Folders icon.
 - To transfer individual Shows, click the Shows icon.
 - To transfer Preset Folders, click the Preset Folders icon.
 - To transfer Presets for individual items, click the Built-In icon or the Plug-In icon and choose a processor or plug-in from the pop-up menu.
 - To transfer Scope Sets for Recall Safe, click the Scope Sets icon.

- 4 Do one of the following to select the items to transfer:
 - In the left column, select the items you want to transfer from D-Show to the portable storage device.
 - or –
 - In the right column, select the items you want to transfer from the portable storage device to D-Show.



Show files selected for transfer from D-Show to USB key disk

- 5 Click the Transfer button.

Large transfers may take time. Transfer status is shown by a progress bar. A transfer may be cancelled by clicking Cancel.

⚠ Cancelled transfers may result in partial folder contents, which will have to be deleted manually.

Synchronizing Settings, Shows and Presets

Instead of transferring data in one direction between the D-Show system and a portable storage device, you can synchronize all data in both columns of the Transfer tab in a single operation.

Synchronizing data causes new files to be copied and files with the same name but a more recent modification date/time to be automatically updated.

⚠ When synchronizing data, D-Show replaces data files of the same name with the file that has the most recent date/time. Check to be sure that the system clock times and time zones are correctly set on the D-Show system and on the computer running D-Show Standalone software when preparing data for synchronization.

To synchronize Settings, Shows, or Presets between D-Show and a portable storage device:

- 1 Go to the Filing page and click the Transfer tab.
- 2 Connect a portable storage device (such as a USB key disk) to D-Show. The device appears above the right column.

3 Do one of the following to select the type of data to synchronize:

- To synchronize all data, click the Console icon.
- To synchronize Console Settings, click the Settings icon.
- To synchronize Show Folders, click the Show Folders icon.
- To synchronize individual Shows, click the Show icon.
- To synchronize Preset Folders, click the Preset Folders icon.
- To synchronize Presets for individual items, click the Built-In icon or the Plug-In icon and choose a processor or plug-in from the pop-up menu.

4 From the pop-up menus above each column, choose the folders containing the elements you want to synchronize.

5 Click the Sync All button. The contents of the left and right columns are synchronized.

Transferring Settings, Shows, and Presets from the D-Show Standalone Software

Using D-Show Standalone software on a laptop computer, you can configure D-Show system routing, set up mixes, create Snapshots, and save Shows and Presets, then transfer them to a D-Show console.

You can create and transfer Console Settings, Shows, and Presets from the Standalone software.

See Chapter 23, “Using the D-Show Standalone Software.”

Undoing Changes Using the History Feature

D-Show automatically saves the current state of the console while you are working, allowing you to quickly return the console to a previous state.

The History feature uses Show files to capture the console state, and displays the files in the History tab.

 *Show Folders and Show files displayed in the History tab can only be deleted. They cannot be duplicated or renamed.*

Show Folders in the History Tab

There are two Show Folders in the History tab:

- ◆ The *Most Recent Changes* folder includes all auto-saved Show files for a ten-hour period.
- ◆ The *Previous Days* folder includes only the last auto-saved Show file for each day since the console was last cleared.

Show Files in the History Tab

The auto-saved Show files displayed in the History Tab are named according to the date and time of their creation, and cannot be renamed.

The Notes field for each auto-saved Show file includes a description of the conditions that caused the automatic save.

Several conditions cause D-Show to automatically save a new Show file in the History tab, as follows:

- ◆ In the course of normal work, a new Show file is automatically saved in the History tab approximately every ten minutes. Saves are less frequent when the console is idle.
- ◆ A new Show file is automatically saved just prior to a significant change in the console setup, including:
 - Change of console channel or bus configuration
 - Recall, storage, or modification of a Snapshot
 - Loading of Console Settings or a Show

Loading an Auto-Saved Show

To return the console to an earlier state at any time, you can load any of the auto-saved Show files displayed in the History tab.

To load an auto-saved Show file:

- 1 Go to the Filing page and click the History tab.
- 2 In the Show Folders column, click the Show Folder name to select the folder and display its contents in the Shows column.
- 3 In the Shows column, click the Show file name for the Show you want load.

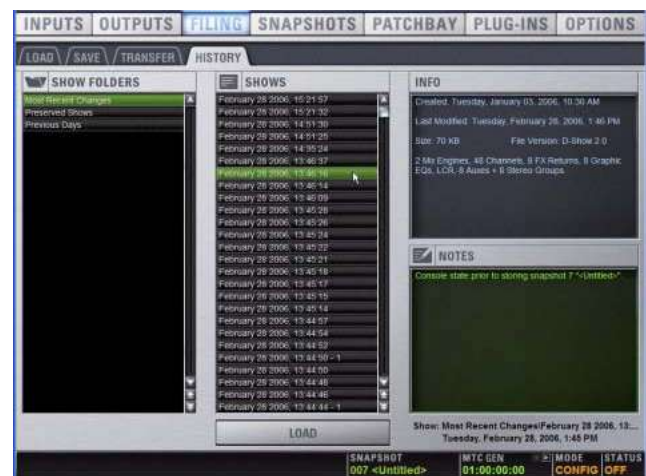

Loading an auto-saved Show file

- 4 Click the Load button.

D-Show loads the selected Show file, replacing the current system configuration, routing, and control settings with those contained in the selected file.

Chapter 21: Snapshots

The D-Show Snapshots feature lets you flexibly store and recall a wide range of console mixing parameters. Snapshots are commonly used to store the mixer setup and levels for individual scenes, songs or sound cues in a performance. Snapshots store information about channels and mix parameters, and you can use a variety of methods to edit, preview, and manage snapshot data.

Snapshots are contained and stored as part of a Show. A single Show file can contain up to 999 snapshots. Snapshots are controlled from the on-screen Snapshots page, or from the dedicated Snapshot controls of the ACS section. Once stored, snapshots can also be recalled with a footswitch.

The selection of data types and channels to be recalled is referred to as the *scope* of a snapshot. The scope of data to be recalled is also stored within each snapshot, and is set using the Data Type Scope buttons and the Channel Scope controls in the Snapshots page. In addition, the Recall Safe page provides global control of automation safe status for individual parameters on specific channels.

Snapshots Page

The Snapshots page provides controls for storing, recalling, and managing snapshots, providing a central location for setting up and replaying automated performances.

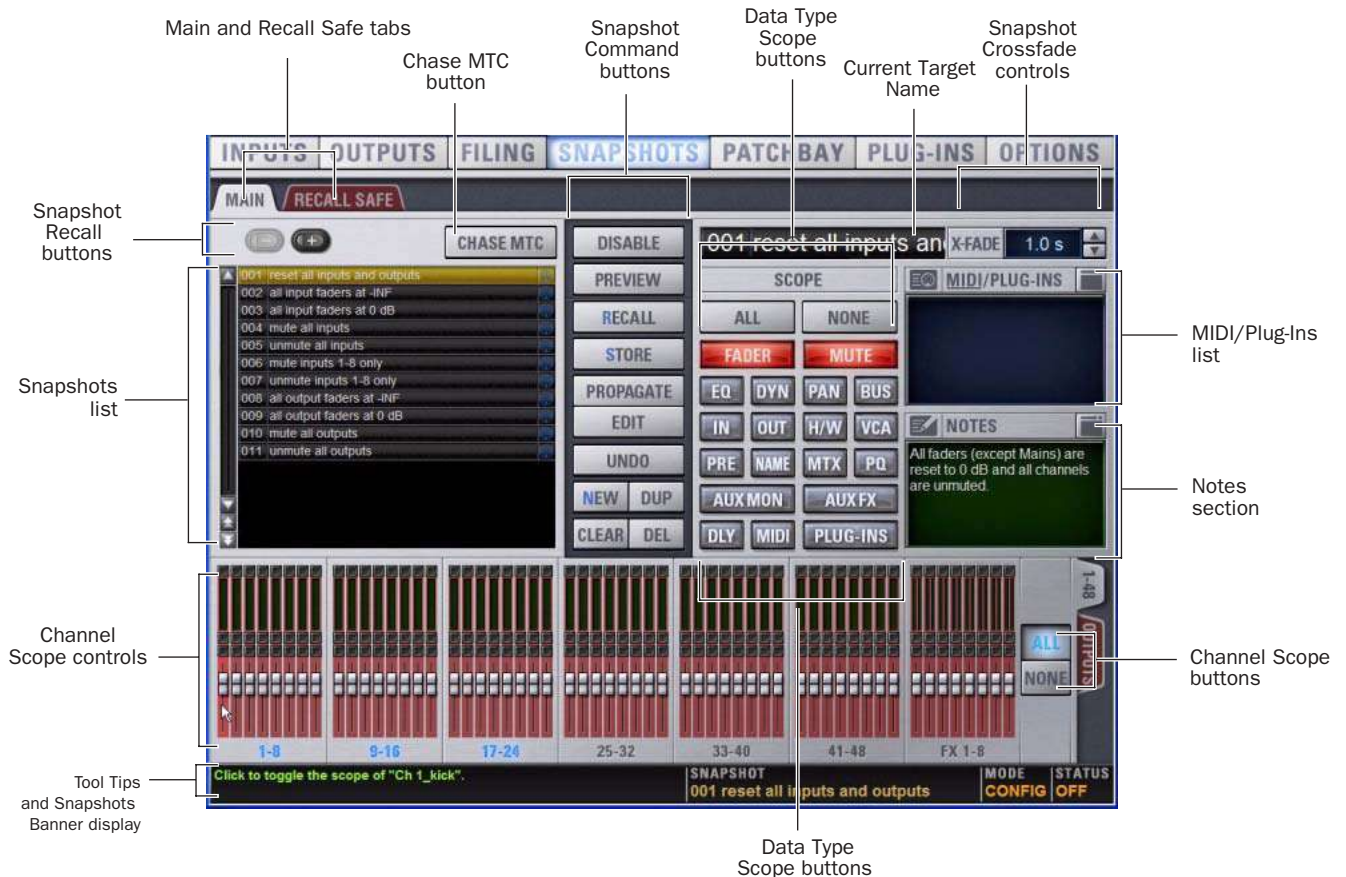

Figure 12. Sections of the Snapshots page

To display the Snapshots page, do one of the following:

- Click the Snapshots tab on-screen.
 - OR –
- Press the Snapshots View Mode switch in the ACS.

 Repeatedly pressing the Snapshots View Mode button toggles through all tabs.

Main and Recall Safe

The Snapshots screen provides the Main and Recall Safe tabs.

Main Provides the primary snapshot controls described in the following sections.

Recall Safe Provides a matrix of channel parameters which can be globally safed from Recall for all snapshots.

Snapshots List

Snapshots can be targeted, renamed, recalled, previewed, edited, reordered, duplicated, searched and deleted from the Snapshots list.

Snapshot Command Buttons

Disable Temporarily disables all snapshot functions.

Preview An “offline” mode in which the console continues to process audio using its settings at the time Preview is invoked, letting you recall, edit and manage snapshots without affecting the current mix.

Recall Recalls the targeted snapshot, updating the console to reflect the status of all scoped data types and channels in the snapshot (subject to the current Recall Safe settings).

Store Stores the current state of the console in the targeted snapshot for all data types and channels, overwriting any existing data in the snapshot.

Propagate Enables Propagate mode. Lets you apply isolated changes to one or more snapshots at once (such as updating a channel EQ across all snapshots).

Edit Enables Edit mode. Lets you adjust parameters freely and apply those changes to one or more snapshots. Changes can be applied in Absolute or Relative fashion.

Undo Returns the console to its state before the last snapshot command.

New Creates a new snapshot that captures the current state of all data types and channels.

Duplicate Creates a copy of the selected snapshots.

Clear Clears the contents of the targeted snapshot, but retains the MTC information for the snapshots.

Delete Deletes the targeted snapshots.

Snapshot Scope Controls

The Snapshot Data Type buttons and Channels work together, acting as a filter for which data types are recalled for which channels on the console. The buttons and channels indicate which data will be recalled for the currently targeted snapshot.

Scope States

Scoped Red display indicates that the data type or channel is currently scoped and will be affected by snapshot recall.

Not Scoped Gray display indicates that the data type or channel is not currently scoped and will not be affected by snapshot recall.

Data Type Scope Buttons

The Snapshot Data Type buttons display scope status for the corresponding types of controls on the console. See Table 22 on page 189 for a complete list.



Data Type Scope buttons showing different scope states

Channel Scope Controls

Channels may be included or excluded from snapshots. The Snapshot Channel Faders display the scope status of each channel on the console. They also let you preview any changes in fader position or mute state that will result by recalling the targeted snapshot.

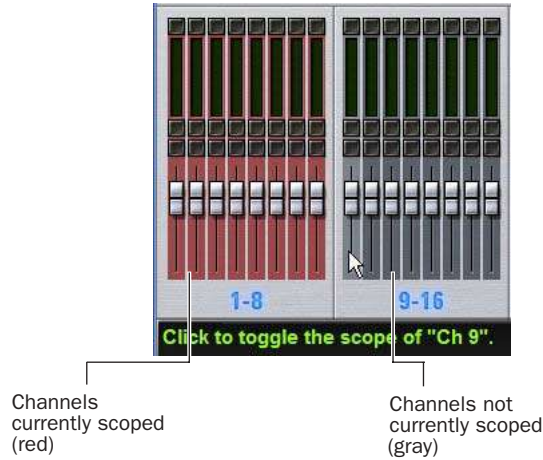

Snapshot channel fader display showing different scope states

Channel Fader Position

When you target a snapshot with scoped channels that have different fader positions from the current fader positions, the target fader positions are shown in bright red.

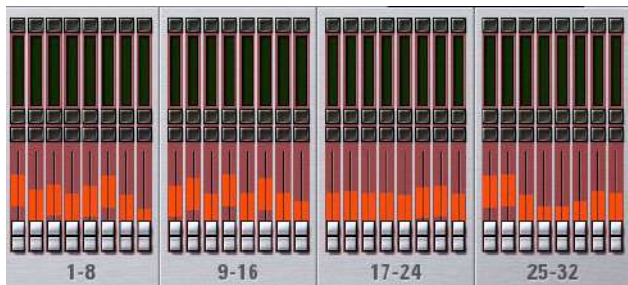

Snapshot channel fader display showing target fader positions

Channel Mute State

When you target a snapshot with scoped channels that have different mute states from the current mute states, the target mute buttons are outlined in yellow.

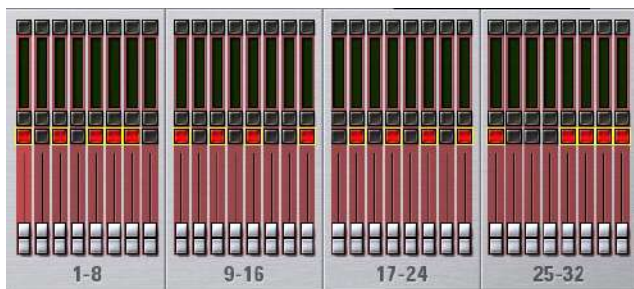

Snapshot channel fader display showing target mute states

Data Type Scope Action Buttons

All Turns on the scope for all data types at once. This is equivalent to clicking all of the Data Type buttons so they are red.

None Turns off the scope for all data types at once. This is equivalent to clicking all of the Data Type buttons so they are gray.

Channel Scope Action Buttons

All Turns on the scope for all channels displayed on the current tab (such as 1–48, 49–96). Double-clicking the All button turns on the scope for all channels on the system.

None Clicking the None button turns off the scope for all channels on the current tab (such as 1–48, 49–96). Double-clicking the None button turns off the scope for all channels on the system.

Snapshot Controls on the D-Show Control Surface

Snapshot controls appear in three locations on the control surface: the Options & Snapshots section in the ACS, the Snapshot Master Controls, and the Snapshot Output Safes. These controls provide direct access to a few basic snapshot commands and allow manual control of snapshot recall.

Options & Snapshots Section

You can target (select), store, and recall snapshots from the Snapshots controls in this section.

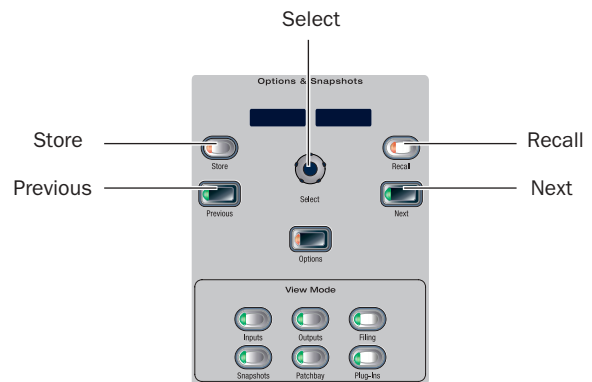

Snapshot controls in the ACS Section

The Snapshot controls in the Options and Snapshots section perform the following functions:

Store Stores the current state of all console parameters in the targeted snapshot. This switch mirrors the Store button in the Snapshots page.

Recall Recalls the targeted snapshot. This switch mirrors the Recall button in the Snapshots page.

Select Encoder and Displays Turning the Select encoder scrolls through and selects the targeted snapshot in the Snapshots list. The displays show the number and name of the currently targeted snapshot. A period is appended to the displayed snapshot name to indicate whenever it has been edited since being recalled.

Previous Instantly recalls the previous snapshot in the Snapshots list. This switch mirrors the Recall Previous button in the Snapshots page.

Next Instantly recalls the next snapshot in the Snapshots list. This switch mirrors the Recall Next button in the Snapshots page.

! *The Previous and Next switches combine target and recall actions in one step, causing the next or previous snapshot to be instantly active. These switches cannot be used to preview snapshots before recalling them.*

Snapshot Master Controls



Snapshot Master Control switches

The following controls are available on the console in the Snapshot Master Controls section:

Safe Selected Lets you put any combination of Input channels and Output channels in automation safe mode. This switch works independently of the Safe switches on Input channels.

Safe All Toggles all Input channels and Output channels on D-Show in and out of automation safe mode. This switch works independently of the Safe switches on Input channels.

Chase MTC Enables automated recall of snapshots when the MTC Read or MTC Generate options are enabled. This switch mirrors the Chase MTC button in the Snapshots page.

Disable Temporarily disables all snapshot functions. The Disable switch lights to indicate that the Disable function is active. This switch mirrors the Disable button in the Snapshots page.

Snapshot Output Safes

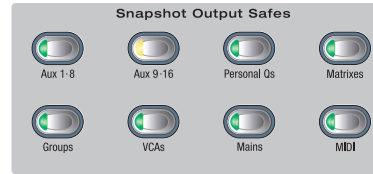

Snapshot Output Safe switches

Output Safe controls the automation safe status of all 8 output channels of a given type; individual output channels cannot be safed with these switches. Use Safe Selected to safe individual outputs. Each switch lights to indicate that the corresponding output type is automation safe. Output Types include:

- Auxes (1–8 and 9–16)
- Personal Qs
- Matrixes
- Groups
- VCAs
- Mains
- MIDI

The MIDI Safe switch mirrors the function of the MIDI Snapshot Output Safe option. See “Safing MIDI Message Output” on page 186.

Snapshots List

Snapshot Entries

Each entry in the Snapshots List has a number (001–999) and name. If either the MIDI Read or Generate feature is enabled, each snapshot will also have a time code value, trigger indicator, or send indicator.

Recall Buttons

The Recall Previous (–) and Recall Next (+) buttons at the top of the Snapshots List cause the previous or next snapshot to be targeted and recalled in one step.

Chase MTC

Enables or suspends automated recall of snapshots when either the MTC Read or MTC Generate options is enabled.

Navigating the Snapshots List

Snapshots are highlighted in color in the Snapshots list to indicate the following:

Green Indicates the last recalled snapshot

Red Indicates the currently targeted snapshot

Yellow Indicates that the snapshot is both the last recalled and currently targeted snapshot

Blue Indicates that the snapshot is part of a multiple snapshot selection but not the last recalled or currently targeted snapshot. Recalled and Targeted snapshots can also be part of a multiple selection in the list. In this case, the sequence number is blue while the rest of the name is red, green or yellow.

Snapshot Keyboard Shortcuts

When the Snapshots page is displayed, you can perform the following Snapshot functions with these keyboard shortcuts:

Snapshot Function	Keyboard Shortcut
Target Next/Previous Snapshot	Up/Down Arrow keys
Target First Snapshot in List	Home key
Target Last Snapshot in List	End key
Target Snapshot at Top of Page	Page Up
Target Snapshot at Bottom of Page	Page Down
Select Multiple Contiguous Snapshots	Shift-click snapshots
Select Multiple Non-Contiguous Snapshots/Deselect any Snapshot	Ctrl-click snapshots
Select All Snapshots	Ctrl+A
Create New Snapshot	Ctrl+N
Recall Targeted Snapshot	Ctrl+R
Store Targeted Snapshot	Ctrl+S
Undo	Ctrl+U
Add or update MIDI/Plug-in data to snapshot	Right-click MIDI/Plug-ins entry

Selecting Snapshots

You can select single snapshots or multiple snapshots in order to target, recall, duplicate, edit, or delete them in the snapshots list.

To select multiple contiguous snapshots:

- Shift-click the snapshot names in the Snapshots list.

To clear a selection of multiple contiguous snapshots:

- Click any snapshot name in the Snapshots list.
 - or –
- Turn the Select knob in the ACS section.

To select or de-select non-contiguous snapshots:

- Ctrl-click the snapshot names in the Snapshots list.



Multiple items selected in the Snapshots list

Snapshot Type Text Search

Type Text search lets you use the keyboard for fast navigation of the Snapshots List.

To search for and target a snapshot:

- 1 Go to the Snapshots page.
- 2 Do one of the following:
 - Type the number of the snapshot.
 - or –
 - Type the first letters of the snapshot name.
- 3 Press the Tab key to cycle through any snapshots that start with the same letter.

Creating Snapshots

Snapshots can be created at any time to store the current channel and parameter settings. You can create new snapshots manually in the Snapshots page (see “Creating New Snapshots” on page 174), or by duplicating existing snapshots to build your mix as you work.

 Use the first snapshot in a Show file to establish the basic settings for the performance. For subsequent snapshots, use the scope controls and Recall Safe settings to selectively recall only those controls that need to change between sections or songs, leaving other controls unaffected by snapshot recall.

Creating New Snapshots

When you create a snapshot, it captures the current state of all console settings.

To create a new snapshot:

- 1 Set all parameters on the console whose state you want to store in the snapshot.
- 2 Click New. The new snapshot appears in the Snapshots List.
- 3 For each channel you want affected when the snapshot is later recalled, click the channel so that it is scoped (displayed in red).

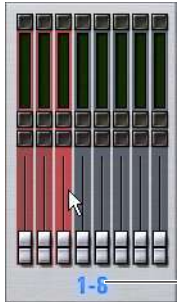

Click to select-/de-select bank

Adding channels to the scope of a snapshot

 To quickly select (or de-select) banks of channels, click their blue labels below the Channel Faders in the Snapshots page.

- 4 For each parameter of the scoped channels you want affected when the snapshot is later recalled, click the corresponding Data Type button so that it is scoped (displayed in red).



Adding data types to the scope of a snapshot

 When you create a new snapshot it automatically inherits the channel and data type scope of the currently targeted snapshot.

 The New command can be undone.

Naming Snapshots

New snapshots are automatically numbered and appear as “<Untitled>” in the Snapshots list. Snapshots can be renamed at any time. You can undo snapshot naming operations.

To name a snapshot:

- 1 Do one of the following:
 - Double-click the snapshot name in the Snapshots list or the current target name display.
 - or –
 - Right-click the snapshot name and choose Rename.
- 2 Type a name for the snapshot.
- 3 Press Enter on the keyboard or click another snapshot name.

Adding Notes to Snapshots

You can add notes to snapshots at any time. You do not need to store the snapshot to save the notes in the snapshot.

To add or edit comments for a snapshot:

- 1 Double-click the Notes header or click the list icon to expand the Notes field.
- 2 Double-click in the Notes field and enter text.

Recalling Snapshots

Targeting Snapshots

Targeting a snapshot lets you preview which data types and channels will be affected by that snapshot before recalling it. When a snapshot is targeted, the on-screen Data Type buttons and Channel Faders update to show the data types and channels enabled for recall by the snapshot.

 Preview mode lets you take the console offline to recall and edit snapshots in their entirety without affecting the current mix. See “Preview Mode” on page 182.

To target a snapshot, do any of the following:

- Click the snapshot name in the Snapshot list.
- Type the number or name of the snapshot on the keyboard.
- Press the Home/End, Page Up/Page Down, and Up/Down Arrow keys to navigate the Snapshot list.
- Turn the Select knob in the ACS to scroll through the Snapshot list. Snapshot numbers and names appear in the displays above the Select knob.

The current target snapshot is highlighted in red in the Snapshots list.

Recalling Snapshots

You can do the following when recalling snapshots:

- Target and instantly recall successive snapshots (next or previous)
- Target first, then recall one or more snapshots
- Select multiple snapshots and recall them all sequentially
- Target snapshots, change Data Type or Channel Scope settings, then recall.

A *Undoing snapshot recall commands might cause audio to be interrupted. Use Undo with caution in performance.*

Recalling Successive Snapshots Instantly

You can instantly recall successive snapshots in the Snapshots list. This command references the previously recalled snapshot, not the last targeted snapshot.

To instantly recall successive snapshots, do one of the following:

- Click the Recall Previous (–) or Recall Next (+) button at the top of the Snapshots list.
– or –
- Press the Previous or Next switch in the ACS section.

A *The Snapshot Recall buttons combine target and recall actions in one step, causing the previous or next snapshot to be instantly active. These buttons cannot be used to preview snapshots before recalling them.*

Targeting Before Recalling Snapshots

To target and then recall a snapshot:

- 1 Target the snapshot you want to recall by clicking the snapshot name in the Snapshot list, or turning the Select knob in the ACS.
- 2 (Optional) Set the scope of the snapshot by doing the following:
 - For each channel you want to recall in the snapshot, click the channel so that it is scoped (displayed in red).
 - For each parameter of the scoped channels you want to recall in the snapshot, click the corresponding Data Type button so that it is scoped (displayed in red).
 - Configure the Recall Safe page to further filter snapshot data on recall. (See “Recall Safe and Channel Automation Safe” on page 175.)
- 3 Click the Recall button on-screen, or press the Recall switch in the ACS.

A *Snapshot Recall can also be triggered by a D-Show foot-switch, as configured in the Options > Interaction page.*

Selecting and Recalling Multiple Snapshots

You can select and recall multiple snapshots to load them all in sequence, and in one step. This is useful to quickly reset the console to a sub-cue or other specific point within a longer scene or cue and “pick up from there.”

To recall multiple snapshots:

- 1 Select multiple snapshots in the list (Shift-click to select multiple adjacent (contiguous) snapshots; Ctrl-click to select non-contiguous items or to deselect a single item.
- 2 Press the Recall switch, or click the Recall button on-screen.

A *If multiple snapshots are selected, toggling Data Type or Channel Scope buttons affects all selected snapshots. This provides a quick way of removing a channel or data type (such as EQ) from some or all snapshots. This action can be undone using the Undo button.*

Recall Safe and Channel Automation Safe

The Recall Safe tab in the Snapshots page provides global automation safe settings of nearly every section of the console.

You can also place individual channels in automation safe from the console or on-screen. For more information, see “Automation Safing Channels” on page 178.

Recall Safe

Recall Safe lets you select which parameters on which channels you want to be ‘safed’ from snapshots, and which you want recalled.

Recall Safe is global to all snapshots, can be turned on or off quickly, and provides preset capabilities in the form of Scope Sets. Scope Sets can be loaded and saved just like D-Show Presets for built-in EQ, Dynamics, and plug-in settings. Current Recall Safe settings are stored with the Show file.

Recall Safe Tab

The Recall Safe tab opens the Recall Safe page on-screen. The Recall Safe tab is displayed in red when Recall Safe is on and in effect, and in gray when Recall Safe is off or when nothing is safed.



Indication of active Recall Safe from the main Snapshots page

Recall Safe Displays and Controls



Displays and controls in the Recall Safe page

On

The master On button toggles the entire Recall Safe feature on or off globally. When lit (blue), Recall Safe is active. When dark, Recall Safe is suspended.

Snapshot List, Recall and Store

The Snapshot List and its Recall and Store functions remain visible and available from the Recall Safe page at all times.

Channel Tabs

The Inputs and Outputs tabs at the top of the parameter matrix selects the channel type whose safe status you want to view or edit. Along the left side of the parameter matrix are channel Type selector tabs, which will change depending on whether you are viewing Input or Output tabs.

 *Shift-click channel type tabs to view more than one type at once in the scrollable parameter matrix.*

Global Safe for MIDI Output and Plug-Ins

These checkboxes let you globally suspend MIDI output and/or plug-in changes from being recalled. They are considered separate from the parameter matrix and do not follow the Recall Safe master On (or Off) status.

Scope Sets

Scope Sets are presets for the Recall Safe page that can be stored and loaded, just like plug-in, EQ and Dynamics presets. Scope sets can be used as a template when creating new shows, or used to change Recall Safe settings during a perfor-

mance. Like other D-Show presets and settings files, Scope Sets can be transferred from the Filing page, making it easy to maintain and transfer Recall Safe configurations. For more information, see “Using Scope Sets” on page 178.

Parameter Matrix

The parameter matrix is a scrollable grid in which you can safe parameters and channels. You can undo and redo parameter matrix operations.

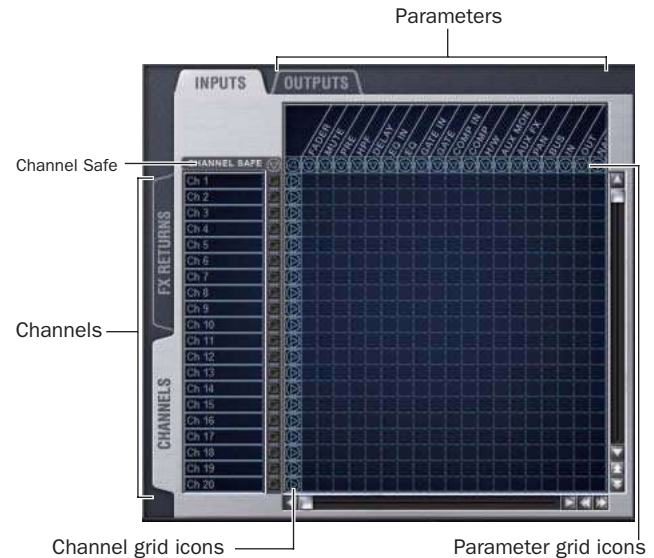

Parameter matrix for Recall Safe

Parameters are represented in the columns of the parameter matrix; channels are listed along the left side in rows.

Clicking in the grid enables safe status for that parameter on that channel. Parameter and Channel grid icons provide shortcuts to “safe all” parameters in a single-click, and to safe entire channels. Clicking these icons lets you quickly toggle recall safe status for entire columns and rows. You can also use the master grid icon located in the upper left most corner to toggle the entire grid.

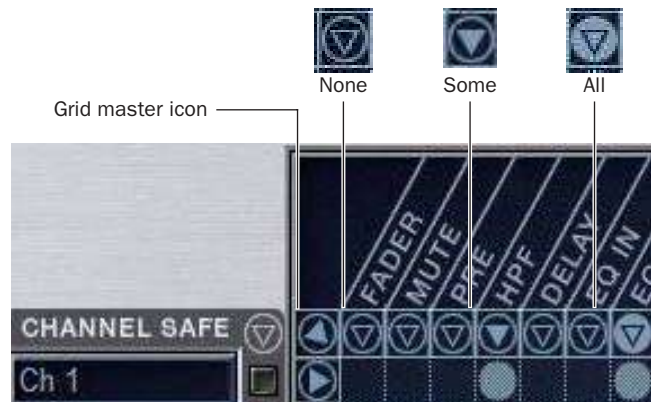

Display states for grid icons in Recall Safe

The display state of the Parameter and Channel grid icons indicate safe status for that column or row as follows:

None A dark Parameter or Channel grid icon indicates that no items in that column or row are safe enabled.

Some A dark triangle inside a lit blue circle indicates that at least one item in that column or row is safe enabled.

All A lit (white) triangle indicates that all items in that column or row are safe enabled.

Channel Safe Controls

The CHANNEL SAFE column mirrors the SAFE switch on the console and on-screen. Controls in the CHANNEL SAFE column are not part of the parameter matrix; they function *in addition to* the parameter matrix and act as a global “all channel” setting or override. As a result, you do not need to enable any CHANNEL SAFE settings to use the Recall Safe parameter matrix.

 For more information, see “Automation Safing Channels” on page 178.

Using Recall Safe

To access the Recall Safe page:

- 1 Do one of the following:
 - Go to the Snapshots page and click the Recall Safe tab.
 - or –
 - Double-press the Snapshot View switch until the Recall Safe tab is displayed.
- 2 Click a channel type tab to display the desired channels.

To safe individual parameters on specific channels:

- Click in the grid at the intersection of the appropriate parameter (column) and channel (row). A blue dot appears, indicating a parameter is safed.



Enabling recall safe for channel 1 fader

To safe multiple parameters or channels at a time:

- Click and drag in a column, across a row, or at an angle.

To safe individual parameters or channels using the computer keyboard:

- 1 Place the cursor above the grid, above a parameter or channel name, or above any Channel Safe button. To be sure the cursor is above a valid area, you should be able to see at least one parameter name or channel name highlight.
- 2 Use the Arrow keys of the computer keyboard to move the cursor right, left, up, or down to other grid points. (You cannot navigate to parameter or channel grid icons, or to the Channel Safe column.)
- 3 Press Enter to enable or disable safe status for the currently focused grid point. Continue navigating to and toggling safe status of other parameters and channels.

To safe a parameter across all currently displayed channel types:

- Click the Parameter grid icon at the top of the appropriate column until the triangle is white.

To safe all parameters for a particular channel:

- Click the Channel grid icon in the ALL column for that channel (row).

To toggle the status of a parameter column or channel row:

- Click the appropriate Parameter or Channel grid icon repeatedly until it displays the desired status. For more information, see “Parameter Matrix” on page 176.

To safe all parameters across all channels and clear any current settings:

- Click the triangular icon at the top of the ALL column.

 You can undo or redo the last action taken in the parameter matrix.

Channel Safe

To automation safe an individual channel and retain all recall safe settings for that channel:

- Click in the CHANNEL SAFE column for the desired channels.

 A channel (row) Channel Safe button does not need to be lit in order to Recall Safe individual parameters for that channel.

To automation safe all parameters across all channels and retain all current recall safe settings:

- Click the CHANNEL SAFE master icon at the top of the Channel Safe column.

 The Channel Safe column mirrors the channel automation Safe controls. For more information, see “Automation Safing Channels” on page 178.

MIDI

To enable Recall Safe for MIDI Snapshot output:

- Click the MIDI Snapshot Output Safe button, located above the parameter matrix.

 For more information, see “Adding MIDI Messages to Snapshots” on page 185.

Plug-Ins

To enable Recall Safe for plug-ins:

- Click the Plug-In Snapshot Safe button, located above the parameter matrix.

 For more information, see “Adding Plug-In Data to Snapshots” on page 186.

Using Scope Sets

The configuration of the Recall Safe page can be stored as a Scope Set settings file. Scope Sets can be previewed, recalled and transferred just like D-Show plug-in, EQ and Dynamics settings.

To store the current Recall Safe settings as a Scope Set:

- 1 Configure the Recall Safe page as desired.
- 2 Click the Scope Sets icon (the folder icon located above and to the right of the parameter matrix).
- 3 Click New.

To preview and recall a saved Scope Set:

- 1 From the Recall Safe page, click the Scope Set icon to display the Scope Set window.
- 2 If necessary, click the appropriate Scope Sets folder by clicking and selecting it from the Folder selector.

3 Do any of the following:

- To preview an existing Scope Set, click its name in the Scope Sets window.
- To load the currently selected Scope Set, press Enter or click the Close box (X) in the Scope Sets window title bar.
- To cancel without changing Recall Safe settings, click Cancel.



Scope Sets window

 See Chapter 20, “Shows and File Management” for instructions on creating custom folders and transferring D-Show data.

Automation Safing Channels

You can suspend the effect of snapshots on individual channels using any of the following Automation Safe controls:

Input Channel Safes Temporarily suspend the effect of snapshots on individual Input Channels and FX Returns from the control surface.

Output Safes Temporarily suspend the effect of snapshots on the following categories of outputs, from the Snapshot Output Safe section of the control surface: Aux 1–8, Aux 9–16, Personal Qs, Matrixes, Groups, VCAs, Mains, and MIDI.

Safe All Temporarily suspends the effect of snapshots on all channels. Safe All lets you continue to recall, store and manage snapshots while the channels are safed. This switch is located in the Snapshot Master Controls section.

Safe Selected Temporarily suspends the effect of snapshots on selected channels. This is a latching mode that lets you select multiple Input and Output channels. This switch is located in the Snapshot Master Controls section.

On-Screen Safe Buttons Each on-screen channel has a safe button that controls its Channel Safe status.



On-screen Automation Safe button

 You can also control channel automation safe status in the Recall Safe tab. See “Channel Safe” on page 177.

To toggle the Safe status of an Input Channel or FX Return directly from the channel strip:

- 1 Go to the Options page and click the Interaction tab.
- 2 Under Input Safe Switches, select the “Act as Automation Safes” option.
- 3 Press the Safe switch on each of the Input Channels or FX Returns you want to safe. The Safe switch lights solid to indicate that the channel is automation safed.

To toggle the Safe status of all outputs of a given category:

- In the Snapshot Output Safes section, press the switch for the Output category. The Output Safe switches light to indicate that all outputs of the corresponding category are safed.

To toggle the Safe status of all channels on the console:

- In the Snapshots Master Controls section, press the Safe All switch. The Safe All switch, the Safe switches on each Input Channel, and all of the Output Safe switches light to indicate they are safed.

 Any channels that were safed individually will remain safe when you use Safe All. When you clear Safe All mode, all channels are unsafed, regardless of their previous state.

To safe any channel with the Safe Selected switch:

- 1 In the Snapshots Master Controls section, press the Safe Selected Switch. The switch flashes to indicate that D-Show is in Safe Selected mode. The Select switches on any previously safed channels flash.
- 2 Press the Select switch on each channel you want to safe. You can select any input or output channel on the console. The Select switches flash to indicate they will be safed.

3 Press the flashing Safe Selected switch to confirm the selection, or press Cancel to leave the channels unsafed.

 Any channels that were safed individually will remain safe when you use Safe Selected mode to safe other channels. However, if you unsafe those channels while in Safe Selected mode, they will remain unsafed when you exit Safe Selected mode.

Managing Snapshots

You can manage snapshots in the list by storing, clearing, duplicating, deleting, or moving them.

Storing Snapshots

You can modify the contents of an existing snapshot, overwriting it with new settings, using the Store command. It is not necessary to recall a snapshot to store it. Snapshots can be stored from on-screen or from the snapshot controls in the ACS section of the console. You can undo Store commands.

To store the current console state in an existing snapshot:

- 1 Set all parameters on the console as you want them to be stored in the snapshot.
- 2 Select the snapshot in the on-screen Snapshot list, or turn the Select knob in the ACS to target a snapshot you want to overwrite.
- 3 Click the Store button on-screen, or press the Store switch in the ACS section.
- 4 Set the scope by doing the following:
 - For each parameter you want to be affected when the snapshot is recalled, click the corresponding Data Type button so that it is scoped (displayed in red).
 - For each channel you want affected when the snapshot is recalled, click the channel fader so that it is scoped (displayed in red).

Clearing Snapshots

The contents of a snapshot can be cleared while keeping the snapshot in the Snapshot list and retaining its MTC information. This lets you maintain a placeholder that you can use later to store new data. You can undo Clear commands.

To clear the contents of a snapshot:

- 1 Select the snapshots you want to clear.
- 2 Click Clear. Cleared snapshots are renamed “<Empty>.”

Duplicating Snapshots

Snapshots can be duplicated from the Snapshots list. You can undo Duplicate commands.

To duplicate snapshots:

- 1 Select the snapshots you want to duplicate.
- 2 Do one of the following:
 - Click “Dup” (Duplicate).
 - or –
 - Right-click the snapshot name and choose Duplicate.

A copy of each selected snapshot is placed after the selection, with a plus sign (+) appended to the original snapshot name.

If multiple snapshots are selected in the list, the new (duplicate) items are added below their original source snapshots.

Deleting Snapshots

Snapshots can be deleted from the Snapshots list. You can undo Delete commands.

To delete snapshots:

- 1 Select the snapshots you want to delete.
- 2 Do one of the following:
 - Click “Del” (Delete).
 - or –
 - Right-click the snapshot name and choose Delete.

The snapshots are removed from the Snapshots list, and succeeding snapshots are renumbered.

Moving Snapshots

Existing snapshots can be rearranged in the Snapshots list. When you move one or more snapshots, they are automatically renumbered in the list, but MTC values are left unchanged. You can undo a snapshot move.

To move a snapshot, do one of the following:

- Drag the currently selected snapshots to a new location in the Snapshots list.
- or –
- Double-click the snapshot number in the Snapshots list or the banner display, type a new number, and press Enter on the keyboard.

Making Changes to Snapshots

There may be situations where you need to change specific parameters in existing snapshots while leaving other parameters unchanged.

For example, if a guitarist changes instruments in the middle of a tour it might be necessary to change levels and EQ on the guitar channel in all the snapshots in a show. D-Show provides the following modes to accommodate these types of situations:

Edit Mode Lets you capture individual control changes while you mix, and apply those changes to one or more pre-existing snapshots as absolute or relative changes. For example, you could enter Edit mode the first time a guitarist uses a new guitar in rehearsal or performance. When you are satisfied with your settings you can apply them (in absolute or relative fashion) to update other snapshots. See “Using Edit Mode” on page 180.

Propagate Mode Lets you update data in pre-existing snapshots after you've already made changes and decided you want to keep them. While Edit mode requires you to know ahead of time that you will be updating snapshots, Propagate mode lets you decide to update other snapshots with current settings after making adjustments to your mix. For example, after the third consecutive night of reaching to increase gain on the DI channel for a new guitar you could use Propagate mode to quickly take the gain increase you just made and apply it to other snapshots. See “Using Propagate Mode” on page 181.

Using Edit Mode

Edit mode is a powerful way to update specific parameters across multiple snapshots without overwriting any settings you want to preserve. By entering Edit mode before making adjustments, you can edit a single control or any number of controls, and your changes are tracked from the point Edit mode was entered.

 *The ability to edit a single control in Edit mode provides more selectivity than Propagate mode.*

Absolute and Relative Edits

Changes can be applied to one or more selected snapshots as *absolute* or *relative* values. Any parameter can be edited in absolute fashion; all dB parameters can be edited in relative fashion.

Examples of Absolute and Relative Edits

Absolute Changing a fader level from 0 dB to -3 dB and applying that change results in that fader being set identically to -3 dB in all selected snapshots.

Relative Changing a fader level from 0 to -3 dB and applying that change results in that fader being reduced by that amount in all selected snapshots, or 3 dB relative to the value previously stored in the snapshot(s). For example, a channel previously at -6 dB would be changed to -9 dB.

Making Relative Changes with Mixed Data Types

If a combination of dB and non-dB parameters (such as gain and EQ frequency) are edited and applied in relative fashion, the dB parameters are adjusted as relative (delta) changes and the non-dB are applied as absolute changes.

To update specific parameters in existing snapshots using Edit mode:

- 1 Navigate to the main Snapshots page.
- 2 Click the Edit button to enter Edit mode. The Edit button changes into two smaller flashing buttons: Abs, and Rel. D-Show begins tracking all changes while you make them.



Edit mode

- 3 Adjust any combination of snapshottable parameters on the console or on-screen.
- 4 Select the snapshot(s) to which you want to apply your edits.
- 5 Click either of the flashing buttons Abs (for Absolute) or Rel (for Relative). You can cancel Edit mode by pressing the Cancel button on the control surface, clicking the Cancel button on-screen, or by pressing the ESC key on your computer keyboard.

The selected snapshots are updated according to your changes and your choice of Absolute or Relative edit.

Using Propagate Mode

You can use the Propagate command to capture changes and apply them to existing snapshots. Propagate mode is most useful when you realize during the course of mixing that you want to capture your current settings to use in other snapshots. You can undo Propagate commands.

To update specific parameters in existing snapshots:

- 1 Make sure the channel is set as needed.
- 2 Click Propagate. The current data and channel scope is cleared.
- 3 Set the scope to reflect only those parameters you want to update by doing the following:
 - For each parameter you want to update, click the corresponding Data Type button so that it is scoped (displayed in red).
 - and –
 - For each channel you want to update, click the channel so that it is scoped (displayed in red).



Propagating an EQ change for a channel

- 4 Select the snapshot or range of snapshots you want to update in the Snapshots list.
- 5 Click Propagate. The scoped parameters are updated in the selected snapshots.

Preview Mode

Preview mode lets you recall, store and edit snapshots without affecting the current mix.

When enabled, Preview mode takes the console offline from the live audio mix so you can “work ahead” during a rehearsal, performance or event to preview upcoming snapshots and edit them as needed. Any control that can be stored and recalled by snapshots is available while in Preview mode, and you can also modify the Snapshot List. Once you are done previewing or editing snapshots, you can store your changes to update the existing snapshots with your changes.

Using Preview Mode

The basic workflow for using Preview mode is as follows:

- 1 Make sure your active mix is set as desired, and make sure the rehearsal, event or performance has an upcoming opportunity for you to go offline.
- 2 Enter Preview mode by pressing F1 on the console, or by clicking the on-screen Preview button in the main Snapshots page. The word “PREVIEW” flashes in red across the screen for confirmation; on the console, the F1 (Preview) switch flashes, as do all input and output channel strip displays.



Preview mode

- 3 Do any of the following:

Edit the Snapshots List Reorder snapshots in the list, if desired, by clicking and dragging them. Changes to the order of items in the Snapshots list may affect the current active mix if the affected snapshots rely on MIDI or MTC triggering. (For more information, see “Changing Console Settings in Preview Mode” on page 183.)

Create a New Snapshot Adjust settings as desired and create a new snapshot by clicking New. (See “Creating New Snapshots” on page 174.)

Recall and Edit an Existing Snapshot Recall a snapshot to preview its settings and make any adjustments necessary, being sure to re-store the snapshot before exiting Preview mode. Storing a snapshot in Preview mode does not affect previously stored MIDI or Plug-in data (if any).

Edit Channel and Scope Settings Edit any channel settings, parameters, or scope associated with the snapshot being previewed. The Snapshots page displays the current snapshot name in italics to indicate that at least one parameter has been changed, and the Channel Faders show you the previous level for each channel in bright red. Scope Data Type buttons and Channel Scope functionality remain live and active at all times (in other words, changes made to these controls while in Preview mode will remain once Preview mode is exited).

Add and Edit MIDI or Plug-In Data To add MIDI or plug-in data associated with the snapshot, click the Add button in the MIDI or Plug-Ins snapshot list. With plug-ins this adds the current online plug-in settings to the snapshot. If you need to update pre-existing MIDI or plug-in data associated with a snapshot, right-click the corresponding entry in the MIDI/Plug-ins view of the Snapshots page and choose the Update option (this option will include the plug-in rack position, and the name of the associated snapshot). For more information, see “Plug-Ins and MIDI in Preview Mode” on page 184.

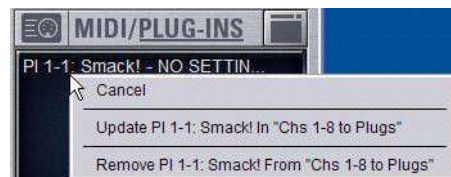

Updating snapshot plug-in data

- 4 To undo an action made while in Preview mode, click the Undo button on-screen. (For more information about Undo in Preview mode, see “Making Changes to Snapshots” on page 180.)
- 5 To update the currently previewed snapshot but remain in Preview mode, press or click Store.
- 6 Continue previewing and editing settings as needed (all snapshot functions are available in preview mode).
- 7 When you are finished and need to exit Preview mode, press F1 (or click the on-screen Preview button).

⚠ *Exiting Preview mode without storing will discard the changes made while in Preview mode (Preview mode is cleared each time you exit). You must explicitly store changes to update the associated snapshots.*

Undo and Preview Mode

In Preview mode, you can Undo actions applied to the Snapshot List (such as Recall, Store, New and Duplicate) without affecting the online mix.

 *Multiple levels of Undo are available.*

Changing Console Settings in Preview Mode

D-Show tracks any changes to console settings or to the Snapshot List while in Preview mode, but only Snapshot List actions create an Undo point. Choosing Undo will undo the last action you took while in Preview mode, up to a maximum of 100 levels of Undo. Any changes to console settings made after the last Preview action are also undone (the Snapshot screen is returned to its exact state prior to the action that created the Undo point).

Changing the Snapshot List in Preview Mode

Changes made to the Snapshot List are automatically tracked and available for Undo, regardless of whether Preview mode is enabled or not. This includes any Recall of snapshots triggered by incoming MIDI or MTC while in Preview mode.

For example, if a MIDI Snapshot Recall occurs while you are in Preview mode, the online mix will be updated with that snapshot. Pressing Undo immediately after that Recall will undo that Snapshot recall and revert the online mix to its state prior to the Undo.

Consider turning off the Chase MTC option while in Preview mode to disable all MIDI recall of snapshots. In addition, you can always use the D-Show History feature to recover from any unexpected results.

Changing MIDI or Plug-In Data in Preview Mode

Changes made to MIDI and Plug-In data cannot be undone. For more information, see “Adding MIDI Messages to Snapshots” on page 185 and “Adding Plug-In Data to Snapshots” on page 186.

 *Take advantage of D-Show Tool Tips in the banner display to confirm what action the Undo button will revert. See “Undoing Snapshot Commands” on page 184.*

Available and Unavailable Functions in Preview Mode

In order to maintain essential mix indicators and controls while in Preview mode, not all functions are taken offline.

The following sections detail what is and what is not available during Preview mode.

Always Active

Certain D-Show essential mix functions remain live and active at all times, regardless of whether Preview mode is enabled. The following vital mix functions continue to affect or be affected by the console and software:

- Metering (including input, output and dynamics meters, clip and bank clip indicators)
- AFL/PFL
- Dynamics Key Listen
- Monitoring level, Headphone level and Monitoring bus Delay
- Talkback, Osc and 2-Track
- Mute Groups (recall only)
- Recall Safe
- PQ system (remains active, but changes from a PQ Controller are not reflected)
- MIDI snapshot Recall, Chase MTC and Disable (Snapshots)
- Snapshot List and Recall Safe (deleting, adding, or editing snapshots are/will be reflected online and affect the mix)
- History (auto-save)

Recall Safe in Preview Mode

The Recall Safe settings are global, and are applied to filter snapshot data regardless of the current operating mode. For details on Recall Safe and other D-Show automation safe features, see “Recall Safe and Channel Automation Safe” on page 175.

Available and Editable in Preview Mode

Almost all system functions, such as selecting channels and banking faders, are available in Preview mode.

 *Only those controls that can be stored and recalled via snapshots are available for offline previewing and editing. In addition, some snapshot-capable controls have special requirements when using Preview mode (such as MIDI and plug-in data). See “Plug-Ins and MIDI in Preview Mode” on page 184.*

Not Available in Preview Mode

The only controls not available while in Preview mode are those controls which are not able to be stored or recalled via snapshots. In addition, Config mode options are unavailable in Preview mode.

Unavailable functions include the following:

- Make Stereo, or Split to Mono
- Move channels
- Input channel Gain Guess
- Input channel and FX Return Input Direct switch
- Input channel Dyn Pre EQ switch
- Insert mode (plug-ins cannot be edited)
- Digital input source selection (ADAT)
- Enabling or disabling sample rate conversion

 These functions are neither available for offline access in Preview mode, nor do they remain active (online) while in Preview mode. To adjust any of the above settings, you must exit Preview mode.

Config Mode

Config mode is not available while in Preview mode. Pressing the Config switch (or double-clicking the Config/Show mode icon on-screen) displays a dialog box in which you can choose to “Exit Preview” (return to online mix, in Config mode), or “OK” (remain in Preview mode).

The system automatically switches to Show mode if Config mode is active at the time Preview mode is entered.

Plug-Ins and MIDI in Preview Mode

In Preview mode, plug-ins and MIDI operate in a similar way as when using the standalone software.

Plug-Ins in Preview Mode

Recalling a snapshot that contains plug-in data affects the offline (Preview) routing and bypass state of the plug-in only; the online plug-in parameter settings are not recalled, and the online mix is not affected.

The following plug-in functions are available offline in Preview mode:

- Plug-in routing can be changed
- Plug-in rack view can be changed
- Plug-ins can be added to a snapshot to capture its current online parameter settings and (Preview mode) routing

The following plug-in functions are not available while in Preview mode:

- Plug-ins cannot be added to or removed from rack slots
- Plug-in presets cannot be recalled or saved
- Plug-in parameters cannot be changed (you cannot open plug-in windows while in Preview mode)
- Plug-ins cannot be installed

You must explicitly add or update plug-in (or MIDI) data to update snapshots, whether or not Preview mode is enabled. You can do this from the main Snapshot page, or from the plug-in racks.

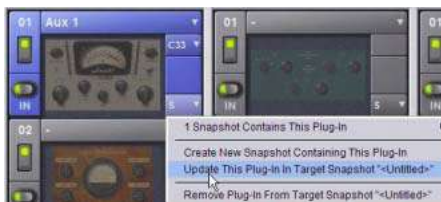

Updating plug-in data in an associated snapshot from the plug-in view

MIDI in Preview Mode

Incoming MIDI or MTC continues to trigger snapshot recall while in Preview mode. However, MIDI messages stored to snapshots are not sent out when a snapshot is recalled in Preview mode. For more information, see “Adding MIDI Messages to Snapshots” on page 185 and “Adding Plug-In Data to Snapshots” on page 186.

Undoing Snapshot Commands

The Undo function returns the console to the state immediately before the last snapshot command. Undo is multi-level (up to 100), is available while in Preview mode and after performing an Edit or Propagate mode action.

 Undoing snapshot recall commands may cause audio to be interrupted. Use Undo with caution in performance.

- ◆ If the Undo button is highlighted, you can place the cursor over the button to display text in the status bar describing what snapshot actions will be undone.
- ◆ If the Undo button is dimmed, Undo is not available.

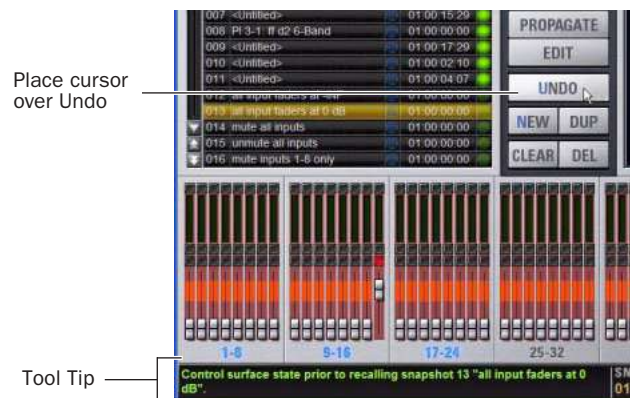

Using Tool Tips to verify the effect of Undo in the Snapshots page

To undo a snapshot command:

- Click the Undo button in the Snapshot commands section.

Disabling Snapshots

You can temporarily disable the storage and recall of snapshots.

To disable snapshots:

- Click the Disable button in the Snapshot commands section.

While snapshots are disabled, you can target snapshots in the Snapshots List to preview their properties, but you cannot recall them.

Adding MIDI Messages to Snapshots

No MIDI message data is captured when a snapshot is first created. MIDI messages are added to existing snapshots directly from the MIDI list. You can store up to 20 MIDI messages in each snapshot.

When the MIDI data type is scoped for a snapshot, any stored MIDI messages are sent when the snapshot is recalled.

The following MIDI messages are supported and available in the MIDI list:

- Note Off
- Note On
- Poly Key Pressure
- Control Change
- Program Change
- Channel Pressure
- Pitch Bend
- MIDI Machine Control Stop
- MIDI Machine Control Play
- MIDI Machine Control Fast Forward
- MIDI Machine Control Rewind
- MIDI Machine Control Eject
- MIDI Machine Control Chase
- MIDI Machine Control Pause
- MIDI Machine Control Locate

When the MIDI data type is scoped for a snapshot, its MIDI messages are sent when the snapshot is recalled.

MIDI Message Indicator



Snapshot ID	Snapshot Name	MIDI Message Indicator	Time Code	Status
001	Snap 001		01:00:03:10	Green
002	Snap 002		01:00:08:00	Green
003	Snap 003		01:00:11:19	Green
004	Snap 004		01:00:20:15	Green
005	Snap 005		01:00:23:19	Green
006	Snap 006	Blue MIDI Message Indicator	01:00:29:23	Red
007	Snap 007		01:00:35:08	Green
008	Snap 008		01:00:38:24	Green

Snapshots List showing snapshot containing MIDI messages

To add a MIDI message to a snapshot:

- 1 Target the snapshot you want to modify.
- 2 Double-click the word “MIDI” in the MIDI/Plug-Ins list header to expand the MIDI list.
- 3 Click Add and choose a message from the pop-up menu.



Adding a message to the Snapshot MIDI list

A MIDI plug icon appears in the Snapshots List for each snapshot that contains MIDI messages.

To record incoming MIDI data to a snapshot.

- 1 Click REC.
- 2 Send a supported MIDI command.
- 3 Click REC again when done.

To edit a MIDI message in the MIDI list:

- 1 Double-click the message text to display the pop-up menu bar for the message.



Editing a MIDI message in the snapshot MIDI list

- 2 Choose the message name and send channel or device ID from the pop-up menus.
- 3 Enter the message values in the text fields or drag up or down across the text field to change the values.
- 4 Click in the MIDI list area to dismiss the pop-up menu bar.

To remove a MIDI message from a snapshot:

- Right-click the MIDI message in the MIDI list and choose Delete.

Viewing MIDI Messages in Hexadecimal Format

You can toggle the view of MIDI messages in the MIDI list between hexadecimal and decimal formats.

To toggle the view format of the MIDI list:

- Click the “Hex” button in the MIDI/Plug-Ins list header.

Safing MIDI Message Output

You can temporarily disable output of embedded MIDI messages so that they are not sent when a snapshot is recalled, even when the MIDI data type is scoped.

 MIDI output is automatically suspended while in Preview mode.

To safe MIDI message output on-screen:

- 1 Go to the Snapshots page and click the Recall Safe tab.
- 2 Click the MIDI global output safe button above the parameter matrix so that it is lit.

MIDI output can also be safed globally from the control surface (see “Snapshot Output Safes” on page 172). This button mirrors the on-screen button on the Recall Safe page.

Adding Plug-In Data to Snapshots

No Plug-In data is captured when a snapshot is first created. Plug-In data is added to existing snapshots from the Plug-Ins list or from the Plug-In rack.

When the Plug-In data type is scoped for a snapshot, plug-in routing, in/out state, and settings are recalled with the snapshot. (Adding or changing plug-in side-chain routing is not supported in snapshots.)

To add plug-in data to a snapshot from the MIDI/Plug-Ins list:

- 1 Target the snapshot you want to modify.
- 2 Double-click “Plug-Ins” in the MIDI/Plug-Ins list header to expand the Plug-In list.

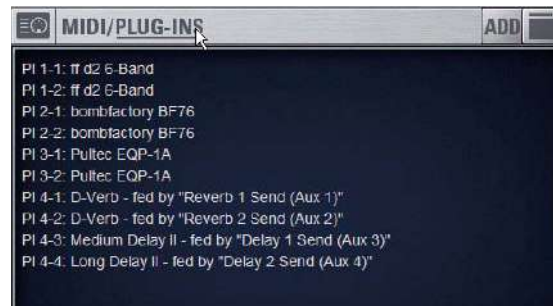

Expanded Plug-In list

- 3 Do one of the following to add one or more plug-ins to the list:
 - To add settings for a single plug-in, click Add and choose the plug-in from the pop-up menu.
 - or –
 - To add settings for all plug-ins currently in the Plug-In rack, click Add and choose All Plug-Ins from the pop-up menu.



Adding a plug-in to the snapshot Plug-In list

To remove plug-in data from a snapshot from the MIDI/Plug-Ins list:

- Right-click the data item in the Plug-Ins list and choose Delete.

To add plug-in data to a snapshot from the Plug-In rack:

- 1 In the Snapshots window, target the snapshot you want to modify.
- 2 Go to the Plug-Ins page to display the Plug-In rack.
- 3 Click the Snapshot pop-up menu (indicated by an “S”) and do one of the following:
 - To add a new snapshot to the Snapshots List with the plug-in data, choose “Create New Snapshot Containing This Plug-In.”
 - To add the plug-in data in the currently targeted snapshot, choose “Add This Plug-In To Target Snapshot.”
 - To update existing data for the plug-in in the currently targeted snapshot, choose “Update This Plug-In in Target Snapshot”



Snapshot pop-up menu in Plug-In Rack

To remove plug-in data from a snapshot from the Plug-In rack:

- 1 In the Snapshots window, target the snapshot you want to modify.
- 2 Go to the Plug-Ins page to display the Plug-In rack.
- 3 Click the Snapshot pop-up menu in the rack slot for the plug-in you want to remove and choose “Remove Plug-In From Target Snapshot.”

Snapshot Options

Crossfade Time

You can set the X-fade (crossfade) time for the channel faders between snapshots from 0–99.9 seconds, in 0.1 second increments. This value determines the *fade time*, or the time it takes for the faders to move to their new positions when a snapshot is recalled.

All other controls are unaffected by the crossfade time, and are updated instantly when a snapshot is recalled. Each snapshot may be assigned its own crossfade time. In addition, crossfades will continue through a subsequent snapshot recall as long as the crossfading channels are not scoped in the incoming snapshot.

Default Crossfade Time

The default crossfade time assigned to new snapshots can be set with this option, with a possible range of 0–99.9 seconds.

To set the Default Crossfade Time:

- 1 Go to the Options page and click the Snapshot tab.
- 2 Under Snapshot General Preferences, enter a value or drag in the text box and press Enter.

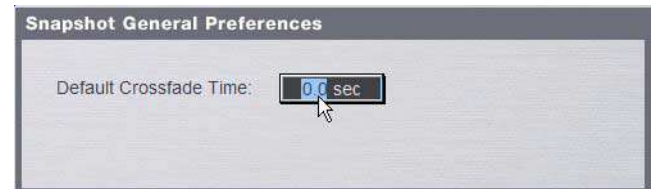

Setting the Default Crossfade Time

Pre Settings

Snapshots can be used to recall the preamplifier settings on inputs for all scoped Input Channels. You can set any of the following Pre parameters to be recalled by the Pre data type button: Gain, Pad and Phase/polarity, +48V (Phantom Power), HPF corner frequency and in/out state.

To set the Pre parameters recalled by the Pre Data Type button:

- 1 Go to the Options page and click the Snapshot tab.
- 2 Under Pre, select the options you want to include. Selected items will be affected when the Pre data type is included in the scope of a snapshot.

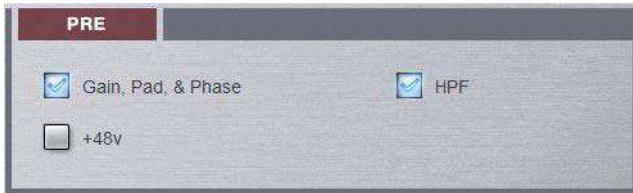

Setting Pre parameters

Classifying Auxes and Variable Groups

You can classify Aux Sends and Variable Group Sends as *monitor sends* (“Mon”) or as *effects sends* (“FX”), which lets you scope each type separately from the Snapshots page.

 This option is only a means of organizing Aux Sends for snapshot control, and does not directly affect Aux bus or Variable Group bus operation.

To classify Aux Sends and Variable Groups for snapshot scope:

- 1 Go to the Options page and click the Snapshots tab.
- 2 For each Aux Send or Variable Group bus or bus pair, click the “Aux Mon” or “Aux FX” buttons to classify it as a monitor send or effects send, respectively.



Classifying Aux Sends and Variable Groups

Aux Pre/Post State

Select this option to include the pickoff point pre-fader or post-fader state of each Aux Send or Variable Group in snapshots.

Snapshot Data Types and Parameters

Table 22. Snapshot data types and parameters included in each data type

Snapshot Data Type	Included Parameters (for Each Scoped Channel Strip)
Fader	Main volume level
Mute	Mute state
EQ	EQ type selection (analog/digital); EQ in-circuit state; 4 bands (2 bands on FX Returns) of gain, freq, Q, bell/shelf selection (digital only), band on/off
Dyn	Compressor/Limiter in-circuit state; threshold, ratio, attack, release, knee, makeup gain Expander/Gate in-circuit state; threshold, ratio, attack, release, hold time, range, side-chain input
Pan	Channel pan or balance/width PQ strip balance Pan or balance/width for each Group bus returning back to L-R
Bus	Group bus assignments, group bus mono/stereo-linked state (if mono groups) or dual-mono/true stereo state (if stereo groups), L-R bus assignment and C/M bus assignments for input strips and groups
In	Input routing for Input Channels and FX Returns
Out	Main out assignments; direct out assignments, level, in-circuit state, & tap-off point (excluding VCAs)
H/W	Hardware insert routing and in-circuit state (excluding VCAs)
VCA	VCA membership
Pre	Gain, pad, phase, phantom power, HPF corner frequency & in-circuit state
Name	Name for each strip
MTX	Level & enable for all 12 Matrix sources plus the user send input (including tap-off point if input is a strip)
PQ	Level, enable, & pan for all 12 PQ sources plus the user send input (including tap-off point if input is a strip), limiter threshold & in-circuit state
Aux Mon	On/off, pre/post selection, level, and pan/balance for each Aux/Var Group bus classified as a Monitor Aux
Aux FX	On/off, pre/post selection, level, and pan/balance for each Aux/Var Group bus classified as an FX Aux
Dly	Channel delay time & in-circuit
MIDI	All MIDI messages that were added to the associated MIDI list for that snapshot.
Plug-Ins	Rack slot settings, in-circuit state, and I/O routing for each plug-in added to plug-ins list for that snapshot

Chapter 22: Synchronization

D-Show provides a set of MIDI-based synchronization features that allow automation and remote control of snapshots, and triggering of external devices when snapshots are recalled.

Automating Recall of Snapshots with MIDI Time Code

D-Show lets you automate the recall of snapshots with MIDI Time Code (MTC). D-Show can trigger snapshots with internally generated MIDI Time Code, or it can read MIDI Time Code from an external source.

Generating MIDI Time Code

You can set D-Show to generate MIDI Time Code and automate the recall of snapshots based on MTC playback.

To generate MIDI Time Code from D-Show:

- 1 Go to the Options page and click the Snapshots tab.
- 2 Under MTC Mode, click Generate. MIDI Time Code generator controls appear at the bottom of the screen.



Setting the MIDI Time Code Mode

- 3 Choose the MTC Frame Rate from the Frame Rate pop-up menu (24 fps, 25 fps, 30 fps drop, or 30 fps non-drop).
- 4 If you want MTC playback to start at a different time than the currently displayed time, enter a start time in the Start Time field, and press Enter.

5 Control MTC playback from the MTC generator controls by doing any of the following:

- Start MTC playback by clicking the Play button.
- Pause MTC playback by clicking the Pause button.
- Stop MTC playback and reset to the Start Time by pressing the Stop button.



MIDI Time Code controls

Reading External MIDI Time Code

You can set D-Show to slave to external MTC and automate the recall of snapshots based on the incoming MTC.

To read external MIDI Time Code:

- 1 Go to the Options page and click the Snapshots tab.
- 2 Under MTC Mode, click Read. A MIDI Time Code display appears at the bottom of the screen.



MIDI Time Code display

D-Show automatically detects the frame rate of the incoming time code (24 fps, 25 fps, 30 fps drop, or 30 fps non-drop).

The MIDI Time Code display indicates the following:

- When MIDI Time Code is not present, the display shows a series of dashes.
- When MIDI Time Code is present, the current time code value is shown in green.

Snapshot MIDI Time Code Display

When D-Show is set to generate or read MIDI Time Code, the Snapshots List shows time code values and a green Recall Enable indicator for each snapshot entry.



Snapshots List showing time code values and indicators

Assigning Time Code Values to Snapshots

With D-Show set to generate or read MIDI Time Code, you can assign time code values to snapshots by entering values manually, or by capturing MTC playback values.

Manually Assigning Time Code Values to Snapshots

To manually assign an MTC value to a snapshot:

- 1 In the Snapshots List, double-click the MTC value you want to change.



Snapshot showing selected MTC value

- 2 Do one of the following:

- From the keyboard, type a new MTC value.
- or –
- Press the Left and Right Arrow keys to move the cursor between number fields, and the Up and Down Arrow keys to increase and decrease the selected value.

- 3 Press Enter or click another snapshot MTC value to accept the entry.

Capturing Time Code Values in Snapshots

To capture the current MTC value in a new snapshot:

- 1 With D-Show in MTC Read or Generate mode, start time code playback.

- 2 Do one of the following:

- During playback, click the New button.
- or –
- Pause playback at the time code value you want to capture, and click the New button.

A new snapshot appears with the time code value at the time of creation.

To capture the current MTC value in an existing snapshot:

- Right-click the snapshot in the Snapshots list and choose Set Timecode To.

The time code value is updated to the currently displayed value.

Sorting Snapshots by Time Code Value

You can sort snapshots in the Snapshots list by Time Code value, so that they appear in chronological order.

 When chasing to MTC, snapshots will always recall in chronological order, regardless of their order in the Snapshots list.

To sort snapshots by their assigned MIDI Time Code value:

- Right-click any snapshot in the Snapshots list and choose Re-Sort All By Time Code.



Sorting snapshots by MTC value

Enabling Snapshots for Automated Recall

With time code values assigned to snapshots, you can then enable snapshots for recall with time code playback.

To enable snapshots for automated recall with MTC:

- Click the Time Code Recall Enable indicator on the right side of the Snapshots list. The indicator turns bright green to indicate that the snapshot is enabled for recall.

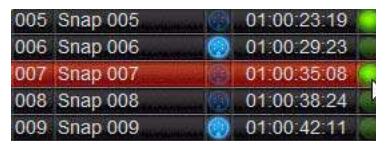

Snapshot enabled for automated recall with MTC

Chasing MIDI Time Code

With snapshots enabled for automated recall, the Chase MTC function needs to be engaged to allow automated recall to occur.

To initiate automated recall of snapshots:

- 1 Click the Chase MTC button so that it is highlighted.
- 2 Begin MTC playback by starting the internal generator (if set to MTC Generate) or the external device (if set to MTC Read).

When a recall-enabled snapshot's time code value is reached, the snapshot is recalled.

The Chase MTC button can be used to quickly take D-Show offline from MTC-triggered recall in performance in the event of a change in timing, such as a missed cue or dropped verse. You can then advance manually to an appropriate snapshot, and re-enable Chase MTC.

⚠ *D-Show does not chase up to the current timecode value. If you start playback in the middle of a snapshot sequence, any prior snapshots will need to be recalled manually to update the console before beginning time code playback. For more information, see “Selecting and Recalling Multiple Snapshots” on page 175.*

Remote Control of Snapshot Recall

D-Show can be set to recall snapshots in response to MIDI control messages sent from an external device such as an AV controller system. You can set the system to respond to control messages sent on any one of 16 available MIDI channels.

Snapshots are recalled when their snapshot number (1–999) is received in the form of MIDI Bank Select and Program Change messages. (See Table 23 on page 193.)

To enable recall of snapshots from an external device:

- 1 Go to the Options page and click the Snapshots tab.
- 2 Under MIDI, select the “Snapshots Respond to Channel” option, and choose the MIDI channel from the corresponding pop-up menu.



Snapshot MIDI respond option

D-Show listens on the specified channel for Bank Select and Program Change messages.

⚠ *The MIDI Snapshot Output Safe option does not affect this option. You can only turn off this feature by deselecting the “Snapshots Respond to Channel” option.*

Table 23. MIDI Bank and Program Numbers for Snapshots

Bank	Program	Snapshot Number
0	0–127	001–128
1	0–127	129–256
2	0–127	257–384
3	0–127	385–512
4	0–127	513–640
5	0–127	641–768
6	0–127	769–896
7	0–103	897–999

💡 *D-Show stores Bank Select messages, so it is not necessary to send a Bank Select message prior to every Program Change message. You only need to send a Bank Select message when you want to recall a snapshot in a different bank from the previous snapshot.*

Triggering of External Devices on Snapshot Recall

D-Show can be set to send MIDI Bank and Program Change messages whenever a snapshot is recalled, to trigger external devices whose cues are related to snapshots. You can set the system to send on any one of 16 available MIDI channels.

 *MIDI output is automatically suspended while in Preview mode. For more information, see “Preview Mode” on page 182.*

While it is possible to add Bank Select and Program Change messages to individual snapshots, this option lets you toggle messages on and off for all snapshots in one step. Using this option also ensures that the Bank Select and Program Change messages correspond to the snapshot number, even after snapshots are rearranged in the Snapshots list.

The Bank Select and Program Changes messages reflect the number (1–999) of the recalled snapshot. (See Table 23 on page 193.)

 *D-Show always sends a Bank Select message before every Program Change message, even if the bank number has not changed from the previous snapshot.*

To enable triggering of external devices when snapshots are recalled:

- 1 Go to the Options page and click the Snapshots tab.
- 2 Under MIDI, select the “Snapshots Send on Channel” option, and choose the MIDI channel from the corresponding pop-up menu.

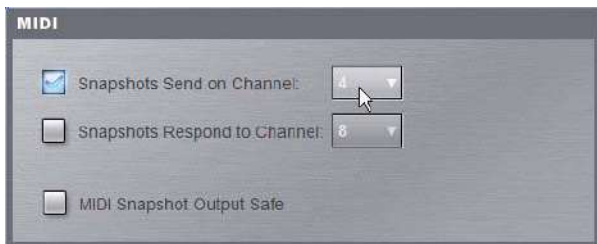

Snapshot MIDI send option

D-Show sends a Bank Select and Program Change message on the specified channel whenever a snapshot is recalled.

 *The MIDI Snapshot Output Safe option does not affect this option. You can only turn off this feature by deselecting the “Snapshots Send on Channel” option.*

Sending MIDI Messages on Snapshot Recall

You can add up to 20 specific MIDI messages to each snapshot. These messages are sent whenever the snapshot is recalled. Sending of the messages is enabled with the MIDI scope control in the Snapshots window. For more information, see Chapter 21, “Snapshots.”

Synchronizing with Word Clock and Digital Audio Input

D-Show receives and outputs Word Clock (at a sample rate of 48 kHz ± 10ppm) for synchronization with a master clock generator (house sync) or other device that uses clock reference.

D-Show can operate as a Word Clock master, or it can slave to Word Clock input.

The Word Clock In and Word Clock Out ports are located on the back panel of the FOH Rack. Additional Word Clock options are available on systems that include a DSI card (Digital Stage Input) in the Stage Rack.

Synchronizing with Digital Audio Input

D-Show automatically synchronizes to the signal on any of its digital inputs, performing sample rate conversion as necessary to the D-Show native sample rate of 48 kHz.

This lets you connect a variety of digital sources (such as a DAT machine or CD player with digital outputs), directly to D-Show.

For instructions on Word Clock and digital audio connections for synchronization, see Chapter 2, “Configuring and Connecting D-Show.”

Chapter 23: Using the D-Show Standalone Software

D-Show Standalone software lets you do all of the following to preconfigure performances, wherever you can use your laptop:

- Learn the basics of the D-Show software interface in preparation for working at a full D-Show system.
- Assign hardware I/O and D-Show routing, and name channels.
- Set channel input, EQ, dynamics, pan, and other settings.
- Create and maintain a library of D-Show setups, with access to nearly all parameters available on the control surface.
- Store and recall Snapshots
- Use D-Show Filing features to transfer Shows, Shows Folders, and plug-in presets to/from a compatible USB storage device to transfer data between the standalone software and D-Show.

 *Transferring D-Show data must be done to/from a compatible USB storage device such as a USB key disk or other external USB hard drive.*

Differences Between Standalone Software and a D-Show System

The Standalone software is nearly identical to that on a full D-Show system, with the following differences:

Audio Throughput

You cannot play audio through the Standalone software. Real-time audio requires the D-Show hardware.

Plug-In Editing

When a Show is transferred from a complete D-Show system, all plug-ins installed on the D-Show system are visible in the Standalone software as *offline* (unavailable) plug-ins. You can assign offline plug-ins to racks, and assign plug-in rack routing in the Standalone software, and save the routing in snapshots.

 *You cannot install plug-ins or adjust plug-in parameters unless you are working on the complete D-Show system.*

Hardware Configuration

In the Standalone software, you can simulate the hardware configuration of a destination system from the Devices tab of the Options page.

System Requirements

The following are the minimum system requirements for using the D-Show Standalone software:

- Computer running Windows XP Pro or XP Home Edition O/S (Macintosh not supported)
- Minimum 1024 x 768 screen resolution
- Minimum 16-bit color graphics, 32-bit recommended
- Minimum 256 MB RAM, 512 MB recommended
- Minimum 200 MB of available hard disk space, 512 MB recommended
- CD-ROM drive for installation (unless installing from web-download)
- Available USB 1.1 or 2.0 port and compatible USB storage device (such as a flash disk, key disk or other external hard drive) for file transfer

Installation requires Windows XP Administrator permissions. Once installed, the software can be run under Admin or User accounts.

Installing the D-Show Standalone Software

To install the D-Show Standalone software:

- 1 Do one of the following:
 - Download the D-Show Standalone Software Installer from the Digidesign Web site (www.digidesign.com).
 - or –
 - Insert your D-Show Software Installer into the CD-ROM drive on your Windows XP-compatible computer.
- 2 Launch the installer and follow the instructions on-screen.

The D-Show Standalone software requires no authorization.

Removing the Standalone Software

To remove the D-Show Standalone software:

- 1 Launch the Add/Remove Programs Control Panel.
- 2 Choose Digidesign D-Show, then follow the instructions on-screen.

Simulating a D-Show Configuration

You can use the Standalone software to simulate a D-Show system with any number of input and outputs. The corresponding inputs and outputs become available in the Patchbay, allowing you to prepare a show that can transfer directly to the destination system.

To simulate a D-Show system:

- 1 Launch the Standalone software.
- 2 Go to the Options page and click the Devices tab.
- 3 Right-click the Stage Rack graphic and choose the number of Input and Output cards on the destination system.

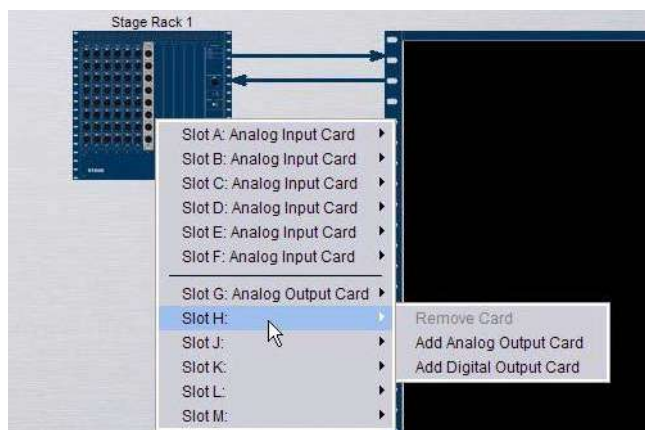

Adding Stage Rack inputs and outputs

- 4 Right-click the FOH Rack graphic and add an IOx Option or Pro Tools recording/playback option if they are present on the destination system.

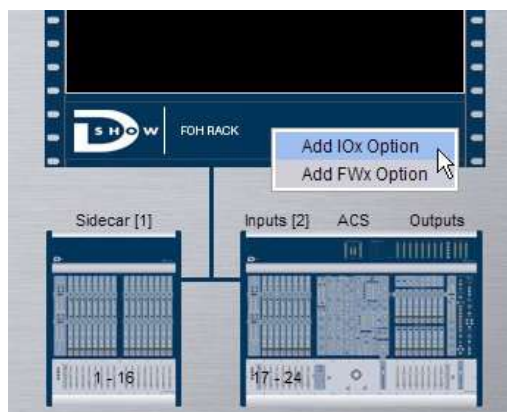

Adding FOH Rack inputs and outputs

Transfer and Filing Quick Start

The basic steps for using the Standalone software and data transfer are as follows:

- Save data to disk, then transfer it to an external USB storage device.
- Transfer data from the USB device, then load the data.

For complete instructions on transferring data, see Chapter 20, "Shows and File Management."

Save and Transfer Data from a D-Show System

To save and transfer data from the complete system:

- 1 Connect a USB storage device to a D-Show USB port.
- 2 Use the Save tab of the Filing page to save D-Show data to disk.
- 3 Go to the Filing page and click the Transfer tab.
- 4 Do one of the following to select the type of data to transfer:
 - To transfer all data, click the Console icon.
 - To transfer Console Settings, click the Settings icon.
 - To transfer Show Folders, click the Show Folders icon.
 - To transfer individual Shows, click the Shows icon.
 - To transfer Preset Folders, click the Preset Folders icon.
 - To transfer Presets for individual items, click the Built-In icon or the Plug-In icon and choose a processor or plug-in from the pop-up menu, or click the Scope Sets icon.
- 5 In the left column, select the items you want to transfer from D-Show to the portable storage device.



Transferring Show files from D-Show

- 6 Click the Transfer button.

Transfer and Load Data to the Standalone Software

- 1 Connect the USB storage device to your laptop. Make sure the drive is mounted before proceeding.
- 2 Launch the D-Show standalone software.
- 3 Go to the Filing page and click the Transfer tab.
- 4 Make sure your USB disk is available in the list at right.
- 5 Click the Console, Settings, Show Folders, Shows, Preset Folders, Built-In, Plug-In or Scope Set selectors to select the type of data you want to transfer.



Click

Transferring a Scope Set for the standalone software

- 6 Click the Transfer button. The data is transferred from the USB device to the appropriate D-Show data folders on the laptop.
- 7 If you chose Console, data is automatically loaded and applied. If you chose any other data type, go to the Filing page and click the Load tab, and load the newly transferred data into the Standalone software.

Creating and Editing Shows and Presets

Use the techniques explained throughout this guide to assign routing, rename channels, and to configure other parameters. Then do the following to save and transfer your work to a complete system.

To save and transfer D-Show data from the standalone software to the complete system:

- 1 Connect a USB storage device to an available USB port on your laptop.
- 2 Using the Save tab of the Filing page, save data to disk.
- 3 Go to the Filing page and click the Transfer tab, and transfer saved data to a compatible USB storage device.
- 4 Connect the USB storage device to an available USB port on the complete system.
- 5 Use the Transfer tab of the Filing page to transfer the D-Show data from the USB storage device.
- 6 Use the Load tab of the Filing page to load the transferred data.

CD Transfer

The D-Show FOH Rack provides a CD-ROM drive that can also be used as a source device for D-Show data transfer. (You cannot write data to the FOH Rack CD-ROM drive; it is read-only.)

To use a CD for transfer:

- 1 Using the Standalone software on a laptop or other computer, create and save a show.
- 2 Locate the D-Show folder on the system drive.
- 3 Copy that D-Show folder and its contents to a CD-ROM. Make sure the D-Show folder is at the root level of the CD-ROM.
- 4 Burn or write the disc as a Windows-compatible CD-ROM.
- 5 Insert the CD-ROM into the FOH Rack CD-ROM drive.
- 6 In the Filing screen, select the CD-ROM drive as the source for file transfer.
- 7 When the transfer is complete, eject the CD-ROM.

⚠ Leaving a disc in the FOH Rack CD-ROM drive can slow down the response of some software screens, so it is recommended that you not leave any disc in the drive during a performance. This only applies to the CD-ROM drive in the FOH rack (not the laptop on which you're running the standalone software).

Exporting Patchbay Names to Text

With Standalone software, the contents of each Patchbay page can be exported to a text file. This can be useful for generating an input list (line list) directly from the system. For example, build and customize the Patchbay for an upcoming show, then export and print the channel names list for use during sound check.

To export Patchbay names:

- 1 Go to the Patchbay page you want to export.
- 2 Click the Export to Text button in the upper right corner of the screen.



Export to Text button

The Patchbay names appear in an open text file that you can modify, save and print.

Part VI: Specifications

Chapter 24: Mechanical Specifications

D-Show Main Unit Mechanical Specifications	
Maximum Height (front)	3.2 inches (81 mm)
Maximum Height (rear)	13.7 inches (347 mm)
Maximum Width (with endcaps)	51.7 inches (1313 mm)
Maximum Width (without endcaps)	49.5 inches (125.8 cm)
Maximum Depth	35.5 inches (895 mm)
Weight	121 lbs (55 kg)
Power Requirements	90–260 VAC, 50–60 Hz, 160 W
USB Ports (3)	USB 1.1
VGA Port	DB-15 mini-female (1024 x 768 resolution)
Footswitch Connectors (2)	1/4-inch TRS
FOH Link Connector (to FOH Rack)	MIL connector
Max FOH Link cable length	11 ft (3.35 m)
Console Link (CAN bus) Connectors (2)	XLR3-M (1 male, 1 female)
Console Link Cable Type	110-ohm (digital) cable
Max Console Link Cable Length	Single cable: 25 ft (7.6 m); Total length: 75 ft (22.9 m)

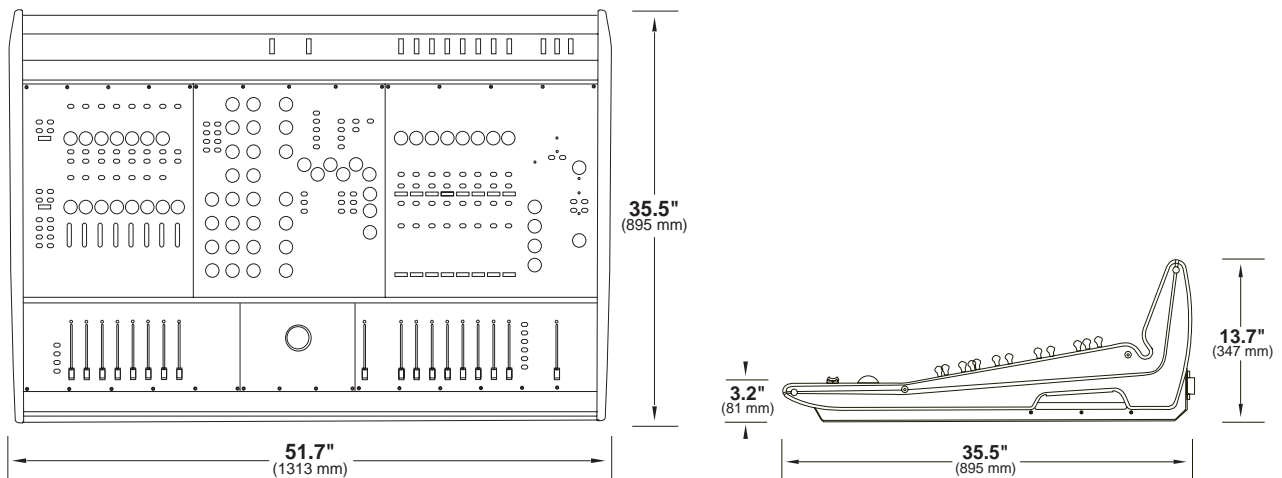

Main Unit dimensions

D-Show Sidecar Mechanical Specifications	
Maximum Height (front)	3.2 inches (81 mm)
Maximum Height (rear)	13.7 inches (347 mm)
Maximum Width (with endcaps)	28.7 inches (729 mm)
Maximum Width (without endcaps)	26.5 inches (673 mm)
Maximum Depth	34.8 inches (884 mm)
Weight	73 lbs (33.2 kg)
Power Requirements	90–260 VAC, 50–60 Hz, 120 W
Console Link (CAN bus) Connectors (2)	XLR3-M (1 male, 1 female)
Console Link Cable Type	110-ohm (digital) cable
Max Console Link Cable Length	Single cable: 25 ft (7.6 m); Total length: 75 ft (22.9 m)

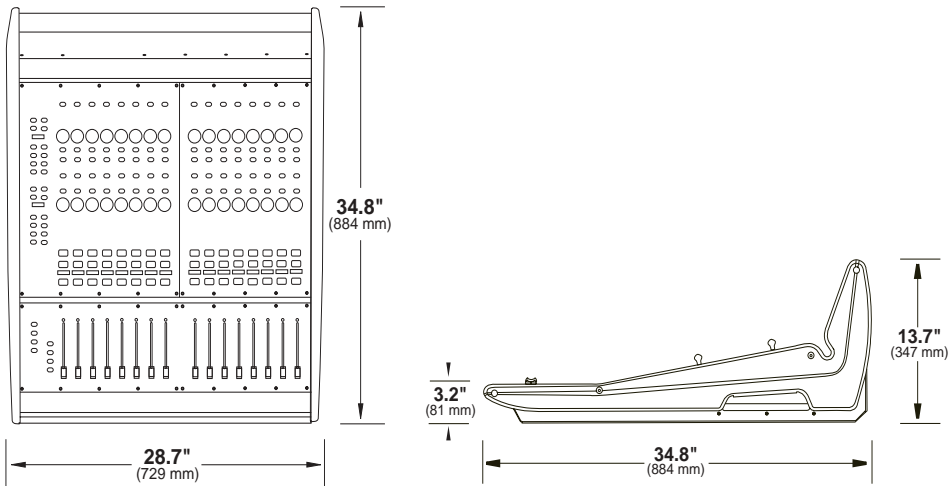

Sidecar dimensions

D-Show Main Unit plus Sidecar Mechanical Specifications	
Maximum Height (front)	3.2 inches (81 mm)
Maximum Height (rear)	13.7 inches (347 mm)
Maximum Width (with endcaps)	78.3 inches (1988 mm)
Maximum Width (without endcaps)	76.1 inches (1933 mm)
Maximum Depth	35.5 inches (895 mm)
Weight	194 lbs (88 kg)
Power Requirements (Main Unit)	90–260 VAC, 50–60 Hz, 160 W
Power Requirements (Sidecar)	90–260 VAC, 50–60 Hz, 120 W
Console Link Cable Type	110-ohm (digital) cable
Max Console Link Cable Length	Single cable: 25 ft (7.6 m); Total length: 75 ft (22.9 m)

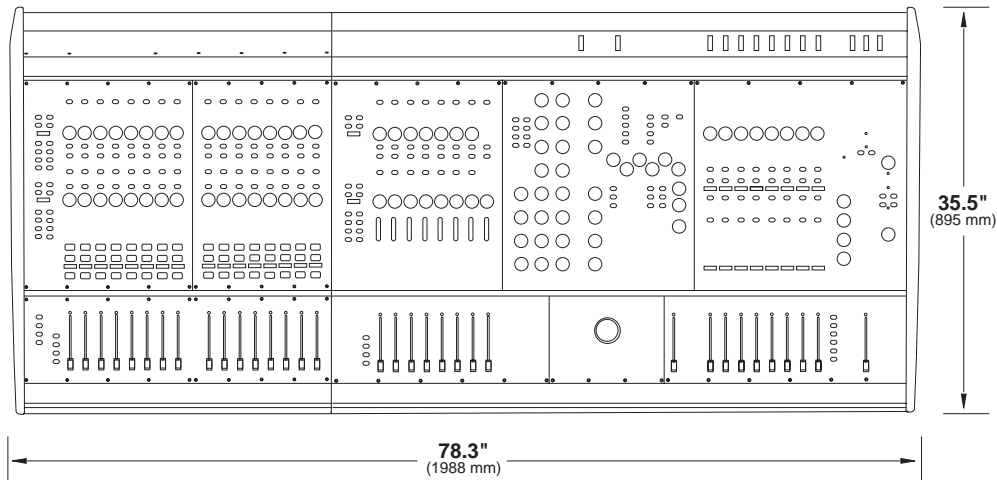

Main Unit plus Sidecar dimensions

D-Show Stage Rack Specifications (maximum configuration)	
Dimensions (H x W x D)	17.5 x 17.0 x 12.2 inches (445 x 432 x 310 mm)
Rack Spaces	10 U
I/O Card Slots	12 (6 input, 6 output)
Weight	86 lbs (39 kg)
Power Requirements	90–260 VAC, 50–60 Hz, 140 W
Snake 1 In/Out Connectors (to FOH Rack)	BNC female (2)
Snake 2 In/Out Connectors (to FOH Rack)	BNC female (2)
Snake Cable Type	75-ohm coaxial cable
Snake Cable Length	250 ft (76 m) or 500 ft (152 m)
PQ Link Connector (to PQ Rack)	XLR4-M
PQ Link Cable Type	110-ohm (digital) cable
Max PQ Link Cable Length	15 ft (4.6 m)

D-Show FOH Rack Specifications (Maximum Configuration)	
Dimensions (H x W x D)	17.5 x 17.0 x 15.1 inches (445 x 432 x 384 mm)
Rack Spaces	10 U
Weight	74 lbs (33.7 kg)
Power Requirements	90–260 VAC, 50–60 Hz, 220 W
Snake 1 In/Out Connectors (to Stage Rack)	BNC female (2)
Snake 2 In/Out Connectors (to Stage Rack)	BNC female (2)
Word Clock In/Out Connectors	BNC female (2)
USB Ports (2)	USB 2.0
FOH Link Connector (to Main Unit)	MIL connector
Max FOH Link Cable Length	11 ft (3.35 m)

Chapter 25: Audio Specifications

D-Show Console

Internal Sample Frequency	48 kHz
External Sample Frequency	48 kHz +/- 10 ppm (word clock input)
Processing Delay	less than 2.8 ms (96 channels, stage input through L-R bus to stage output)
Internal Processing	up to 48-bit, fixed point 288 dB internal dynamic range
Frequency Response	+/- 0.5 dB (22 Hz – 20 kHz BW, relative to 1 kHz)
THD + N	less than 0.01% (Stage Input to L-R bus, input gain @ min, +4 dBu output, 22 Hz – 20 kHz BW)
Dynamic Range	108 dB typ
Maximum Voltage Gain	84 dB (Stage Input to L-R bus, channel & L-R faders @ max)
Crosstalk	-100 dB typ (Adjacent Stage inputs to L-R bus, @ 1 kHz)
Residual Output Noise	-90 dBu typ (22 Hz – 20 kHz BW) *

Stage Rack

SRI Analog Input Card

Connector (x8)	XLR3-F
Phantom Power	+48V (individually switchable per channel via software)
Maximum Input Level	+34 dBu, with pad *
Pad	20 dB
Gain	+10 dB to +60 dB
Input Impedance	pad off: 40 K ohm balanced pad on: 1.33 IK ohm, balanced
EIN	126 dBu typ (Max gain, 150 ohm source, 22 Hz – 20 kHz BW) *
LEDs	signal presence (indicates -37 dBu or greater), +48V
A/D	24-bit, delta sigma

SRO Analog Output Card

Connector (x8)	XLR3-M
Maximum Output Level	+24 dBu *
Output Impedance	50 ohm
LEDs	signal presence (indicates -37 dBu or greater), mute
D/A	24-bit, delta sigma, 128x oversampling

* 0 dBu = 0.775 V rms

 See the Expansion Options Guide for audio specifications on Stage Rack expansion options.

FOH Rack

FOH Rack IO (Standard)

Com Input

Connector	Neutrik combi XLR/TRS
Phantom Power	+15V @ 6mA (switchable on FOH Rack back panel)
Gain	-2 dBu to -32 dBu, 6 steps
Input Impedance	20K ohms

Analog Inputs 1-8; 2-Track Analog Inputs

Connector	1/4-inch TRS
Maximum Input Level	+24 dBu
Input Impedance	10K ohms

Analog Outputs 1-8; 2-Track Analog Outputs, Monitor L/R

Connector	1/4-inch TRS
Maximum Output Level	+24 dBu
Output Impedance	50 ohms

Digital Inputs (Switchable between AES and S/PDIF)

2-Track AES

Connector	XLR3-F
Format	AES/EBU
Word Length	24-bit
Sample Rate	48 kHz
Sample Rate Conversion	3:1 ratio

2-Track S/PDIF

Connector	RCA co-axial
Format	SPIDF (IEC-60958)
Word Length	24-bit
Sample Rate	48 kHz
Sample Rate Conversion	3:1 ratio

Digital Outputs (Switchable between AES and S/PDIF)

2-Track AES

Connector	XLR3-M
Format	AES/EBU
Level	N/A
Word Length	24-bit
Sample Rate	48 kHz
Sample Rate Conversion	Yes
Dithering	No
Channel Status Info	Pro, Audio 48K, No Emphasis

2-Track S/PDIF

Connector	RCA co-axial
Format	SPIDF (IEC-60958)
Level	N/A
Word Length	24-bit
Sample Rate	48 kHz
Sample Rate Conversion	Yes
Dithering	No
Channel Status Info	Consumer, Audio, 48K, Non-copy, 2-Channel, General Category, Level 2 Clock

FOH Rack IOx (Optional)

Analog Inputs 9–16

Connector	1/4-inch TRS
Maximum Input Level	+24 dBu
Input Impedance	10K ohms

Analog Outputs 9–16

Connector	1/4-inch TRS
Maximum Output Level	+24 dBu
Output Impedance	50 ohms

Digital Inputs 1–4

Connector	XLR3-F
Format	AES/EBU
Word Length	24-bit
Sample Rate	48 kHz
Sample Rate Conversion	3:1 ratio

Digital Outputs 1–4

Connector	XLR3-M
Format	AES/EBU
Level	N/A
Word Length	24-bit
Sample Rate	48 kHz
Sample Rate Conversion	Yes
Dithering	No
Channel Status Info	Pro, Audio 48K, No Emphasis

Main Unit

Talkback Mic Input

Connector	XLR3-F
Phantom Power	+15V @ 6mA (always on)
Sensitivity (fixed)	-20 dBu
Input Impedance	20K ohms

Headphone Output

Connector	TRS unbalanced
Output Impedance	50 ohms
Max RMS Power Output at +21 dBu:	
(with 32-ohm phones)	20 mW
(with 600-ohm phones)	130 mW

Snake

Connector (x4)	BNC
Cable Type	coaxial
Max Length	250 feet (76 m) Belden 1855A 500 feet (152 m) Belden 1694A
Channel Count	48 inputs, 48 outputs

Digital Snake Cable Assemblies

Customers wishing to build their own digital snake assemblies using copper coaxial cable should adhere to the following cable type and length recommendations:

Digital Snake Cable Specifications

Snake Connector	(x4) BNC Male, 75 ohm
Cable Type	Coaxial, 75 ohm
Max Length	250 ft (76 m)
Belden 1855A - single conductor Belden 7787A - three conductor Belden 7788A - four conductor	
Max Length	500 ft (152 m)
Belden 1694A - single conductor Belden 7710A - three conductor Belden 7711A - four conductor Van damme Cable (VDC) 278-175-00 - single conductor	

Check the VENUE sections of the Digidesign Web site for additional information about cable specifications and options (www.digidesign.com).

Chapter 26: Signal Flow Diagrams

D-Show Input Signal Flow Diagram

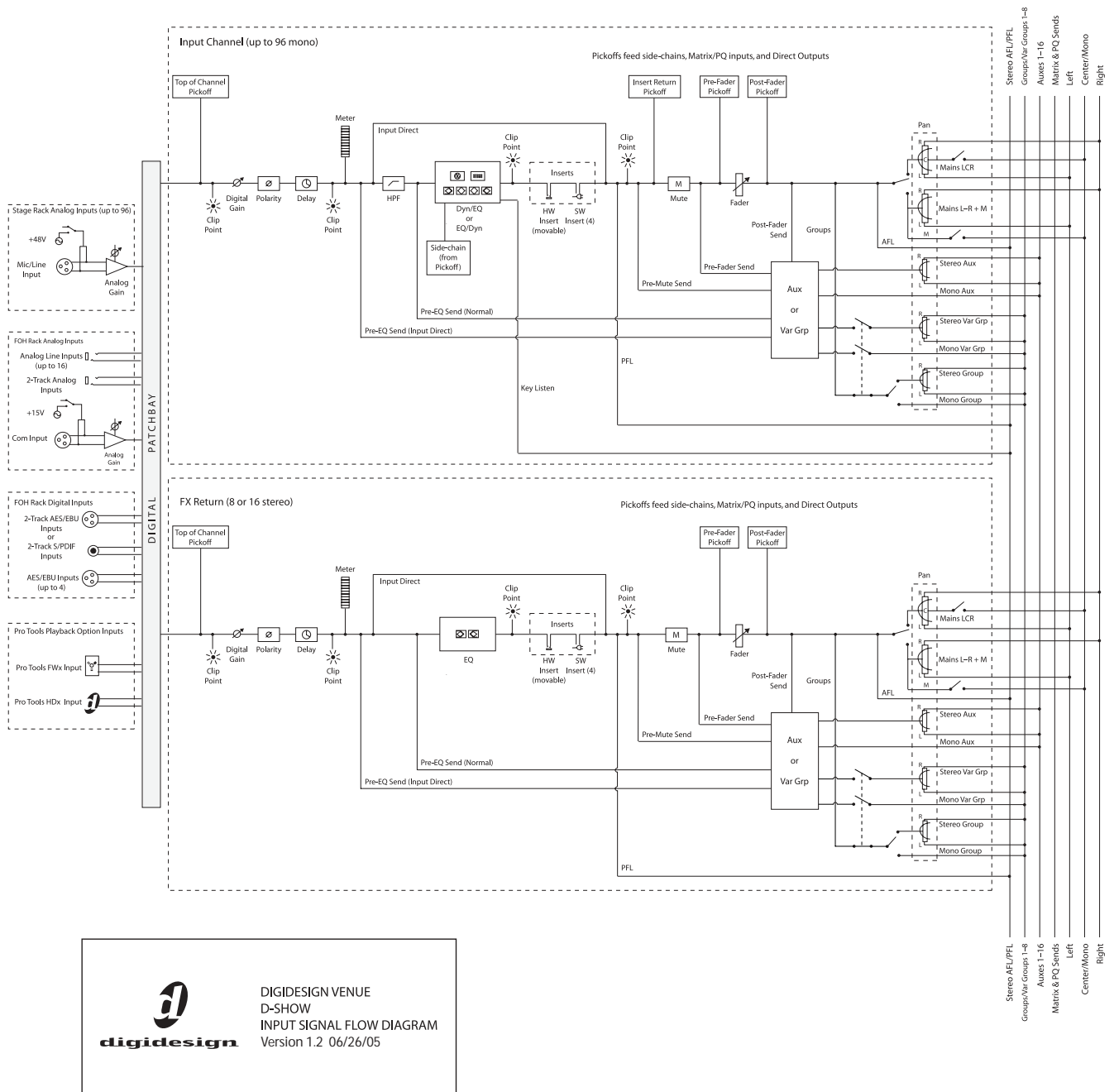

D-Show Output Signal Flow Diagram

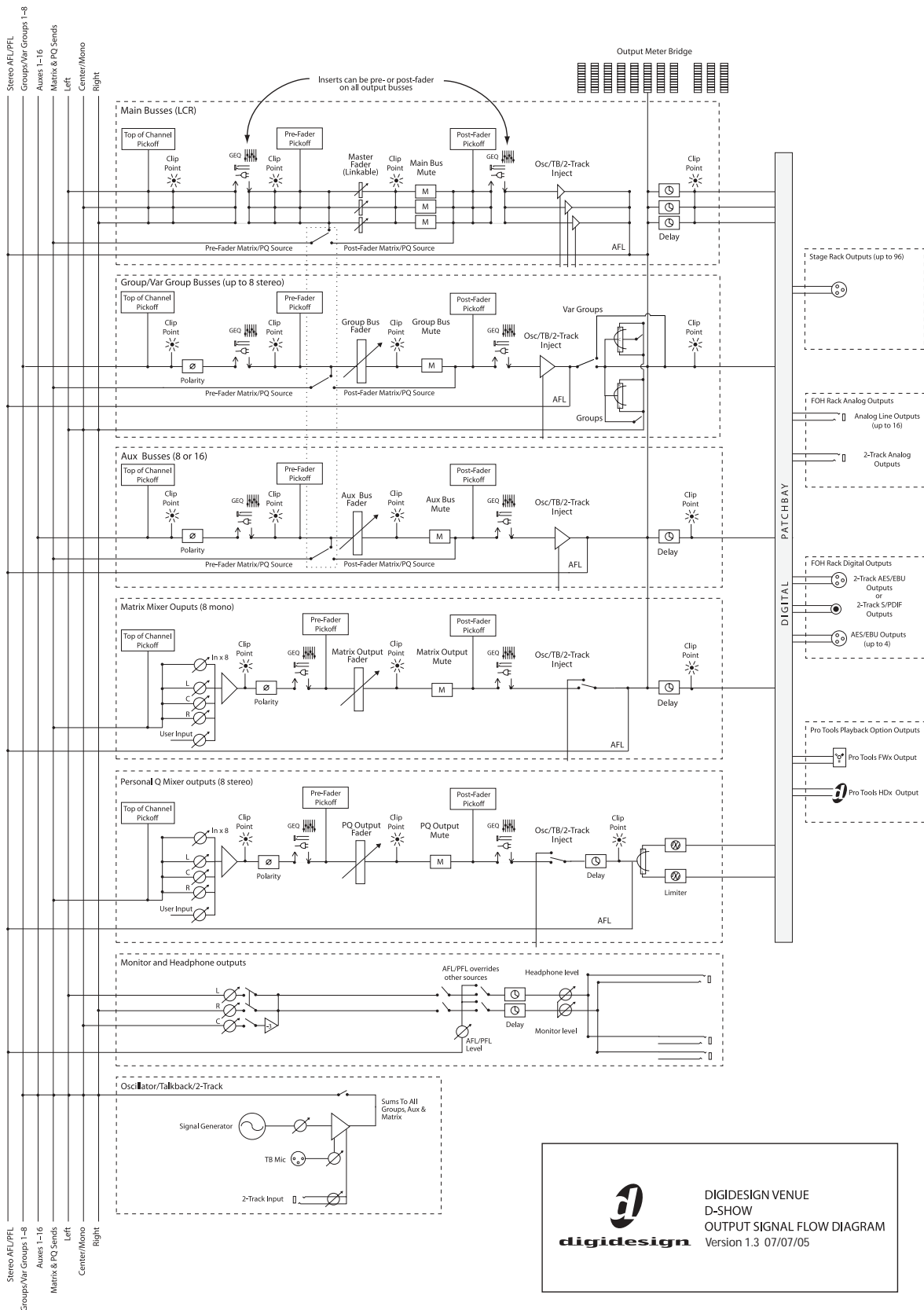

DIGIDESIGN VENUE
D-SHOW
OUTPUT SIGNAL FLOW DIAGRAM
Version 1.3 07/07/05

Chapter 27: Troubleshooting

This chapter provides troubleshooting and problem solving information. It includes a table of problems and solutions that provides answers to common questions, explains D-Show text messages, and refers you to specific sections later in this chapter or elsewhere in this guide for details and instructions.

Problem Solving

The following table provides descriptions of situations that may arise while operating D-Show common questions, symptoms and error messages, along with possible solutions.

Table 28. Troubleshooting D-Show Errors and Messages

Symptom or Message	Possible Cause	Solution
Faders, Switches, Channels, and Units		
Fader stuck	Fader path was blocked during startup calibration	Reset the unit on which the stuck fader resides by right-clicking the unit in the Options > Devices page and choosing Reset. If possible, wait for a silent portion of a performance to avoid unexpected gain changes upon reset. For details, see “Resetting Hardware Components” on page 216).
Only faders and mutes are working	Backup personality is in effect	Wait for the system to recover and follow instructions on-screen to resume operations (see “Resuming Normal Operation” on page 214).
Channel meter Stereo LED is flashing	Indicates a difference of 12 dB or more between the two sides of the stereo signal.	Trim source levels or input gains to balance.
Cannot pan an Aux from the ACS	Aux panning is configured to follow channel pan	In the Options > Busses page, select the Follows Channel Pan option. Deselect for each Aux you want to pan independently from channel pan.
Startup and Restarts		
System failure and restart, then the Resume Operations dialog appears	The D-Show system software has been forced to restart and the backup personality is now in effect.	Continue mixing using features available while the backup personality is in effect (see “In Case of System Failure” on page 213). Follow the instructions on-screen to resume operations after a restart (see “Resuming Normal Operation” on page 214).

Table 28. Troubleshooting D-Show Errors and Messages

Symptom or Message	Possible Cause	Solution
Repeated failures	An incompatible plug-in, a corrupted D-Show data file or application software, or a hardware error.	<p>Check to make sure you are using the most current versions of all your plug-ins (check with the manufacturers). If failures occur only when you try to use a certain plug-in, disable that plug-in and see if problems go away. Try re-installing plug-ins that are causing problems.</p> <p>Determine if a certain Show file causes the system to fail consistently. If so, delete that file and see if problems persist. For additional options, see “Restarting D-Show” on page 215.</p> <p>Clear the console from the Options > System Config page and see if problems persist.</p> <p>If necessary, you can reinstall D-Show software (see “Updating or Re-Installing” on page 216).</p> <p>If you suspect problems with the FOH Rack hard drive, or the D-Show system software, you can do a complete restore (see “Full System Restore” on page 216).</p> <p>Power down all equipment and check all cards and cable connections and power supplies.</p>
Plug-Ins		
The plug-in racks need to be re-initialized	The racks have gone offline. The racks go offline whenever the backup personality is in effect, and after some conditions in which a plug-in or the DSP host failure causes significant problems.	Follow the instructions on-screen to reset the racks (see “Re-Initializing the Plug-In Racks” on page 214).
One or more plug-ins are unavailable	A Show was loaded that references plug-ins which are unavailable on the current system	<p>Install the plug-ins, if available (see “Installing and Authorizing Plug-Ins” on page 145).</p> <p>Remove or replace the plug-ins in the Show, or load a different Show file.</p>
	A plug-in is not fully compatible with D-Show and is causing failures	<p>Check all plug-ins to make sure you are using the most recent versions. Go to Options > Plug-Ins and click the plug-in to display the version number.</p> <p>Try disabling plug-ins one-by-one to see if doing so eliminates problems (see “Enabling and Disabling Installed Plug-Ins” on page 148).</p>
Plug-in authorization dialogs appear every time the system starts or restarts	A plug-in is installed that needs to be authorized for demo or full use.	<p>Click Quit to dismiss the authorization dialog and continue starting up (the plug-in will be unavailable).</p> <p>Click Try to use the plug-in for a limited time in Demo mode.</p> <p>Click Authorize if you are ready to authorize a plug-in using an iLok. (See “Installing and Authorizing Plug-Ins” on page 145.)</p>
	A plug-in demo has expired	Uninstall the plug-in listed in the authorization dialog (see “Removing Plug-Ins” on page 146).
Error Messages		
One or More Units have Failed	Bad or missing connection	<p>Check all cables and connections. Make sure digital grade XLR cables are being used to connect Main Unit and all Sidecar units.</p> <p>Check to make sure that the last Sidecar in the chain is properly terminated.</p>
	A unit needs to be reset	Reset the component in Options > Devices. If necessary, restart D-Show.
Plug-In Racks Need Reset	The racks have gone offline due to the backup personality being in effect, a plug-in has failed, or some circumstances have caused the DSP engines to require a reset.	Follow the instructions on-screen to reset the racks (see “Re-Initializing the Plug-In Racks” on page 214).

Table 28. Troubleshooting D-Show Errors and Messages

Symptom or Message	Possible Cause	Solution
Power Supply Alert	A power supply is failing or is not plugged in. A power supply jumper switch is set incorrectly.	Click Review to show the Options > Devices page. Reset units as needed (see “Resetting Hardware Components” on page 216). Check the power supply jumper switch to make sure it matches the number of installed power supplies in the unit. (See the <i>Redundant Power Supply Installation Guide</i> .)
Control Surface Change	A unit Bus ID has changed, or a new sidecar has been detected.	Click to clear the message. Check unit Bus IDs to make sure input channel strips are arranged as desired.
Date & Time Check	Clock setting of D-Show system should be checked against current time.	Check and reset D-Show system time in the Options > Misc page. Incorrect system time can affect D-Show data transfer and plug-in authorizations. If clock problems persist, the battery in the FOH Rack may need to be replaced.
Sample Rate Conversion Alert SRC OFF LEDs flashing (DSI option only)	A sample rate mismatch or lack of clock has been detected at a digital input.	No immediate action required; automatic sample rate conversion maintains digital throughput, allowing you to check settings and connections between D-Show and external digital devices later. For more information on digital connections and synchronization, see “Digital Inputs and Sample Rate Conversion” on page 14.

In Case of System Failure

D-Show includes multiple redundancy and fail-safe routines that help protect against problems that could interrupt audio. These include the ability to maintain mix control even if a failure occurs, to reset software and hardware components, and to completely reset and reinstall the system software.

For maximum protection, the Redundant Power Supply and Redundant Snake options are available to provide additional backup power and system communication for uninterrupted operation.

Maintaining Mix Control

If at any time the system fails, or if the system is reset or restarted, the D-Show backup mode is automatically engaged to maintain audio throughput and essential mix control.

While the backup personality is engaged, a dialog appears on-screen in the banner display. The system then begins to reset itself in the background, while you can continue to use the faders and mute switches to perform basic mixing. Plug-Ins continue to process audio but their controls cannot be changed until the process is complete.

Features that Remain Active

The following essential mixing features remain available while the backup personality is engaged:

- Bank Input Channels (Banks A–D); adjust levels and mutes. (FX Returns are banked independently of Input Channels.)
- Bank to FX Returns; adjust faders and mutes
- Bank Output faders; adjust faders and mutes
- Control VCA masters, including VCA mutes, and have all members of the VCA group reflect VCA adjustments
- Display the correct name for any fader in its 6-character display, even while banking
- Meter input signals on the channel input meters, and meter bus outputs on the assignable meterbridge. The Selected Channel meter continues to provide metering for the last selected channel. Meter mode selection buttons remain active on meterbridge (however, Meter mode does not automatically follow output selection, if configured to do so).
- Compressor and gate meters remain active for all Input Channels (however, Comp In and Gate In switches are not available)
- Meterbridge System Status LEDs turn off
- Channel select is disabled for all inputs and outputs
- ◆ Switch the Mute Group Masters, and see the effect on the channels with member-mutes (flashing mute switches)
- ◆ All 6-character displays switch to green
- Adjust near-field monitor and headphone levels

Unavailable Features

The following features are unavailable while the backup personality is in effect:

- Use the Assignable Channel Section or fader
- Modify any other mixing parameters apart from faders and mutes (for example auxes)
- Use solos or Solo In Place
- Change the input or output routing, or order of inputs
- Make stereo, or unlink stereo to discrete mono channels
- Change bus or group assignments
- Change VCA membership, or show VCA members
- Change names or access any Filing functions
- Reconfigure any system parameters in the Options screens
- Access GEQs on the Main faders
- Adjust the parameters of any existing Plug-In
- All LED indicators (except meters) and output fader CAL lights go dark and are inactive

Resuming Normal Operation

(Exiting the Backup Personality)

When the system has recovered and is prepared to return to normal operation, the Ready to Resume dialog appears on-screen.



Ready to Resume dialog

Choices in the Ready to Resume dialog give you options for how and when critical functions are brought back online. Utility functions are also provided for reset and diagnostics, as described in the following sections.

⚠ *Because this process can interrupt audio throughput, wait for a silent portion of the performance before confirming (such as a break between songs, intermission, or similar).*

Resume Operations Use this option if you need to wait for a break in a performance to complete the resumption of normal operations.

Reset Mix Engines Use this option to do a full system reset in one step. All operations and controls including the plug-in racks return to full operation. This is the fastest way to resume operations, but it may interrupt audio.

More Options Use this option to clear the console (reset, or “zero” the board), or to perform hardware diagnostics.

Resume Operations

This option begins the process of resuming operations and lets you control precisely when the plug-in racks are re-initialized.

To begin the Resume Operations process:

- 1 Click Resume Operations. The console resets all parameters and configuration settings. When completed, the Plug-In Racks Reset dialog appears to let you initiate the process of re-initializing the plug-in racks.
- 2 Reset the plug-in racks (see next).

Re-Initializing the Plug-In Racks

The plug-in racks are taken offline during a Resume Operation process. Whenever the plug-in racks go offline they will need to be reinitialized to resume normal operation.

⚠ *Do not reset the racks until there is a long enough break in the performance that the rack can be fully rebuilt with no signal passing through. This is especially important when using crossover plug-ins or gain-attenuating plug-ins.*

The following conditions apply when resuming operations

- When offline, plug-ins on Input Channels and FX Returns continue to pass and process audio using their settings at the time the racks went offline.
- Offline plug-ins on output channels and busses are muted.
- You will not be able to adjust plug-ins settings until the racks fully re-initialize.
- Once the racks begin to reinitialize, plug-ins are unavailable and do not process audio.
- During reinitialization, plug-ins are loaded into rack slots according to the last loaded Show file; plug-in racks are turned off (all assigned plug-ins are made inactive).
- When all plug-ins have loaded and the racks initialized, D-Show displays a dialog alerting you that the racks are ready to be brought back online (reactivated). This is provided as a final precaution against sudden changes to audio when plug-ins resume processing.

Shortly after you confirm that you want the racks brought back online, plug-ins resume processing audio and all parameters become available for editing.

To re-initialize (reset) the racks:

1 In the Plug-In Racks Reset dialog, click Reset to begin the plug-in rack re-initialization.



Resetting the plug-in racks

When this step is completed, the Plug-In Racks are Ready dialog appears alerting you that the plug-in racks are ready to be re-activated.

2 Click Use Racks to confirm that you want the racks to be re-initialized. Status is shown on-screen. After the process is complete, the console and all plug-ins are operational again.

Reset Mix Engines

Use this option to do a full system reset in one step. Reset Mix Engines resumes all operations automatically, including the console, settings, and plug-in racks.

⚠ Audio may be interrupted or may change levels during this reset procedure.

To reset the Mix Engines and all operations immediately:

- Click Reset Mix Engines in the Ready to Resume dialog.

Operations are brought back online; no further interaction is required (no warning or confirmation dialogs appear).

More Options

Additional options are provided to clear the console, or to run DigiTest (hardware diagnostics).

To access additional options:

- Click More Options.

After clicking More Options, a dialog is displayed that provides the following options.

Clear Console

- Click Clear Console to reset all D-Show parameters on all channels to their factory default settings.

Run DigiTest

DigiTest is hardware diagnostics software for D-Show. Only use DigiTest at the request of a Digidesign technician to diagnose specific hardware problems.

Restarting D-Show

If D-Show ever needs to be restarted, do the following:

To restart D-Show:

- 1 Turn off all power amps or turn the volume down on all monitoring equipment.
- 2 Press both Reset switches on the front of the FOH Rack simultaneously.

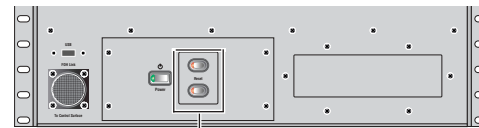

Reset switches

Location of reset switches on FOH Rack

If restarting the system does not correct a problem, you may have to reset other hardware components, identify and remove any incompatible plug-ins, or reinstall D-Show software using the D-Show System Restore CD.

Additional Restart Options

Additional shortcuts are provided while restarting the system, which let you do the following:

- Back up the current show settings and clear the console. Use this option if you suspect an auto-saved setting has become corrupted. This lets you save your most recent settings and clear the console without having to a full system restore.
– or –
- Restart the D-Show processor but launch into Explorer, to manually manage software components. Use this option if to troubleshoot the system if problems arise early in the startup process and persist through repeated restarts.

Backup and Clear Console

To backup and clear the console at restart:

- 1 Start or restart the system.
- 2 Watch the screen closely during the startup process. As soon as the cursor becomes visible (and before the D-Show logo screen appears) press and hold the C key on the computer keyboard. Continue to hold the C key (do not press it repeatedly).
- 3 A dialog appears that lets you choose to backup your auto-saved settings and clear the console, or to continue and load settings normally.

💡 If you press the C key too early in the startup process, the USB keyboard is reset instead of calling the Backup and Clear dialog. If you do not see the backup and clear dialog, repeat the restart process and try again.

Startup in Explorer

To start up the system in Explorer (bypassing D-Show):

- 1 Start or restart the system, as necessary.
- 2 Watch the screen closely during the startup process. As soon as the cursor becomes visible (and before the D-Show logo screen appears) press and hold the E key on the computer keyboard. Continue to hold the E key (do not press it repeatedly) until you see the Explorer desktop.
- 3 From Explorer, you can manually find and delete suspect D-Show data files, plug-ins, or perform other file management tasks.

 *If you are unsure about how to troubleshoot a computer and its files, it is recommended that you contact Digidesign technical support.*

Resetting Hardware Components

D-Show hardware can be reset from the Options > Devices screen, or by power-cycling the component. It is recommended that you perform a reset if, for example, a connected and powered Sidecar stops communicating with the rest of the system.

 *Resetting a hardware device from the Options > Devices page relies on software and therefore requires that the device be in a fairly good state just to receive and process the reset request message sent to it. If in doubt, power cycle the units instead.*

Indication

D-Show will display error messages alerting you if a device fails or is no longer available.

The system remembers the last hardware configuration used. If it doesn't find all units at the next startup, it displays those units as grayed out in the Options > Devices page. Units remain offline (and D-Show displays error messages alerting you to their absence) until either the units are powered up and come online, or you tell the system to forget the offline units by Right-clicking the missing devices and choosing Forget.

A Unit has gone Offline

The Control Surface LED on the meter bridge will flash red. In the Options > Devices page, the failed unit appears grayed out. If a problem has been detected with the power being supplied to a unit, that unit will be indicated by a red circle above the icon for that unit in the Options > Devices page.

To reset system hardware:

- 1 Put D-Show in Config mode.
- 2 Go to the Options page and click the Devices tab.
- 3 Right-click any of the following hardware components:
 - Inputs section of the Main Unit
 - ACS section of the Main Unit
 - Outputs section of the Main Unit
 - Sidecar
 - Stage Rack
- 4 Choose Reset.



Resetting a unit in the Options > Devices page

To reset a Sidecar, you can also do one of the following:

- Change the Bus ID numbers of the unit.
- or –
- Unplug and replug the Console Link connector.

Using the System Restore CD to Update or Restore the System

One copy of the System Restore CD is included with each system. The System Restore CD provides software installers to update or restore a system.

Updating or Re-Installing Updating or re-installing D-Show software lets you replace Digidesign software but preserve any saved Shows and Presets. Use this option to update a system software or firmware, or to re-install software while troubleshooting. Plug-Ins must be reinstalled after updating from the System Restore CD.

Full System Restore Performing a full system restore completely uninstalls D-Show before replacing it with new software. All D-Show data folders and files are removed. Be sure to transfer and archive needed data before performing a system restore. Plug-ins must be re-installed after restoring the system.

 *A System Restore CD and CDs of any plug-in installers should be kept with the system at all times.*

To start, update, or restore system using the System Restore CD:

- 1 Make sure outputs, speakers, and power amps are muted.
- 2 Insert the System Restore CD into the D-Show CD-ROM drive on the FOH Rack.
- 3 Press the two Reset switches on the front of the FOH Rack simultaneously to restart the system, then press and hold F10 on the keyboard until Restore CD text screen appears.

 *Some models of USB keyboards require repeated pressing of F10 (holding it down in between pressings) to register.*

4 Use the Up and Down Arrow keys to select the CD drive (it should be the last choice, with the line starting with “4M-”) choice and press Enter. This launches using the software on the inserted System Restore CD.

5 Do one of the following to update or restore D-Show software:

- To update or re-install D-Show software, press U. Follow the on-screen instructions to begin installation. The installer begins replacing D-Show software on the CPU of the FOH Rack.

– or –

- To do a full system restore (complete remove and replace), press R. (Or press P to return to the previous screen.) A warning dialog appears on-screen asking you to confirm. Press Shift+R (uppercase R) to begin, then follow on-screen instructions to complete the system restore operation.

When finished updating or restoring, the system restarts.

6 Select an option in the Ready to Resume dialog as appropriate (see “Resuming Normal Operation” on page 214).

7 Follow any additional instructions on-screen for plug-ins or authorizations.

8 Remove the D-Show System Restore CD from the FOH Rack CD-ROM drive.

9 Re-install any plug-ins.

To cancel without changing any installed software:

- Press E to exit from the Welcome to D-Show System Restore screen. D-Show resumes starting up using the currently installed version on the FOH Rack CPU.

 *If you cancel a full system restore or an update, you may experience installation errors about unavailable space. If this occurs, repeat the system restore process, making sure to complete it in one pass.*

Updating Firmware

During an update or system restore, D-Show checks for new firmware. If newer firmware is found on the System Restore CD, it is installed while D-Show starts up.

Reinstalling Plug-Ins After Restoring the System

The System Restore CD reinstalls all D-Show system software only. DigiRack Plug-ins and any additional plug-ins from Digidesign or its Development Partners must be re-installed separately.

 *For instructions on re-installing plug-ins, see Chapter 19, “Plug-Ins.”*

Main Unit and Sidecar System LEDs

Each Main and Sidecar unit includes the two Power and Com Link LEDs, located just below the Bus ID selector at the upper left of each unit.

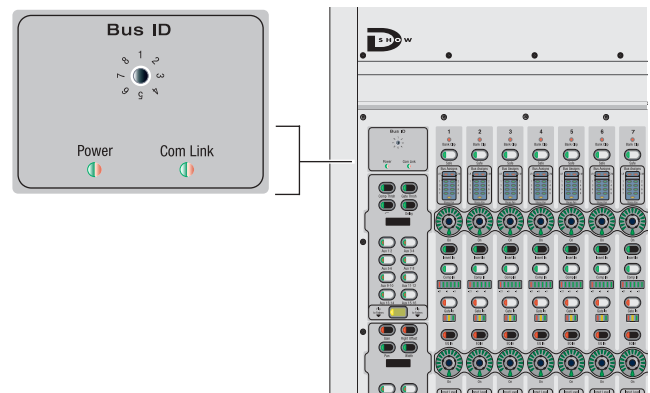

Power and Com Link LEDs

Power LED

Power LED states, on Main and Sidecar units

LED State	Indicates	Action
Green	power supply OK	
Yellow, flashing	power supply problem	Check power and all cables to the unit.

COM LED

COM LED states, on Main and Sidecar units

LED State	Indicates	Action
Green	control surface communication OK	
Yellow, flashing	no communication since firmware boot	Check power and Console Link cables
Red, flashing	communication lost	Check power and Console link cables; power cycle D-Show system.

Meter Bridge Status Indicators

The meter bridge includes five System Status LEDs, as shown in the figure below.

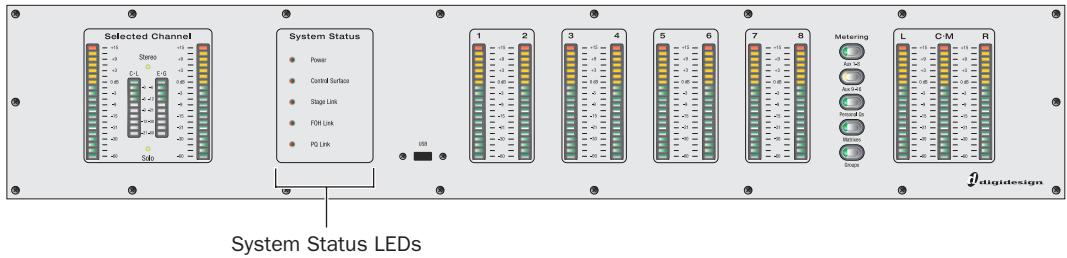

Figure 13. Status LEDs in the meter bridge

Power LED

Power LED states, Meter bridge of Main Unit

LED State	Indicates	Action
Green	Main, Sidecar(s), and FOH are powered On	None required
Yellow, flashing	A failure has occurred with the power supply in the FOH Rack or Stage Rack	Check power and all cables to the unit. Check Options > Devices screen to see if any additional information is available.

Control Surface LED

Control Surface LED states

LED State	Indicates	Action
Green	All Main and Sidecar units are communicating correctly	
Yellow, flashing	At least one unit cannot be found	Check Options > Devices, to see if unavailable hardware is still initialized on the system.
Red, flashing	Lost communication	Check all cables and connections.

If you power up with fewer Sidecars than before, you will need to reset D-Show Devices configuration.

To reconfigure D-Show after removing a Sidecar:

- 1 Go to Options page and click the Devices tab.
- 2 Right-click on the offline Sidecar and choose Forget.

Stage Link LED

Stage Link LED states

LED State	Indicates	Action
Green	Snake communication to Stage Rack OK	
Yellow, flashing	Main Snake failed and taken offline; redundant Snake being used	None required
Red, flashing	No communication with the Stage Rack	Check power and all cables; power cycle the Stage Rack

Note, if the system switches over to the redundant Snake just once, the LED will flash yellow until the software is re-launched (or it turns red due to failure).

FOH Link LED

FOH Link LED states

LED State	Indicates	Action
Green	FOH Rack is communicating correctly	
Yellow, flashing	No communication	Check FOH Rack cable connections to the Main Unit
Red, flashing	Communication has been lost	Check power and other connections to the FOH Rack. Check Options > Devices for additional detail about components within the FOH Rack. Also, check the status of the Control Surface LEDs (described previously)

PQ Link LED

PQ Link LED states

LED State	Indicates	Action
Green	All PQ Controllers are communicating correctly	
Yellow, flashing	At least one PQ Controller cannot be found or is not communicating at all. Or, PQ Rack not is not connected to a Stage Rack.	Check Options > Devices to see if a PQ Controller is still listed that is no longer in use or disconnected. Check all other PQ cable connections and power status
Red, flashing	Communication to at least one PQ Controller (or entire PQ Rack) has been lost	Check power and all cables

If you power up with one less PQ Controller than before, the LED will flash amber until explicitly shut off in Options > Devices.

To reconfigure D-Show after removing a PQ Controller:

- 1 Go to the Options page and click the Devices tab.
- 2 Right-click the offline unit and choose Forget.

Part VII: Reference

Chapter 28: Control Surface Reference

D-Show Main Unit

Main Unit Top Panel

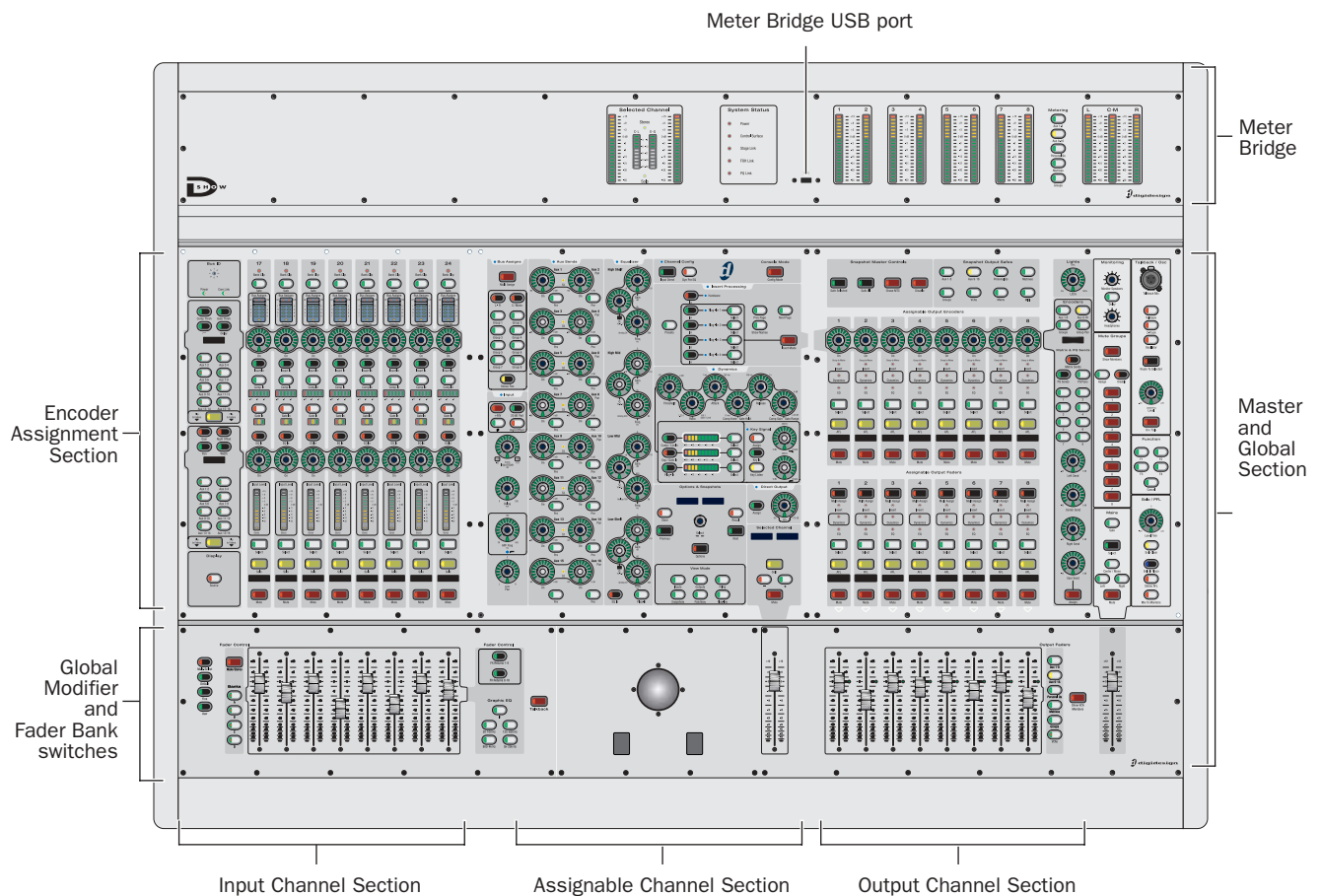

Figure 14. Main Unit top panel sections

Input Channel Section

The Input Channel Section provides 8 channel strips that are used to control Input Channels and FX Returns. Input Channels are used to control input signals from the Stage Rack, FOH Rack, and Pro Tools playback options. FX Returns are used to control return signals from hardware inputs on the Stage Rack, FOH Rack, or Pro Tools playback options.

The Input Channel Section also includes Encoder Assignment controls that are used to assign functions to the two row of rotary encoders.

Assignable Channel Section (ACS)

The Assignable Channel Section provides dedicated controls for bus routing, Direct Output routing, built in EQ and Dynamics processing, and Insert processing (including Plug-Ins). When a channel is selected, its controls are automatically targeted on the Assignable Channel Section.

Output Channel Section

D-show Output controls consist of 8 output channel strips with separately assignable output encoders (AOEs) and output faders (AOFs), and a set of assignment controls for each. This section is used to control output signals from Groups, Auxes, Matrixes, and the PQ Monitoring system.

Master and Global Section

The Master and Global section includes controls for the Main Busses, Monitoring, Talkback, Mute Groups, and the Solo Bus.

Meter Bridge

The Meter Bridge provides system status information and metering information for the selected channel in the ACS, the selected Output bus, and the Main bus.

Meter Bridge USB Port

The USB port on the Meter Bridge is a USB 1.1 port. This port supports iLoks, USB key disks, and USB keyboards.

Main Unit Front Ports

The Main Unit includes the following front ports (Figure 15):

Front USB Port

The USB port on the front of the Main Unit is a USB 1.1 port. This port supports iLoks, USB key disks, and USB keyboards.

Headphone Connector

The headphone connector on the front of the Main Unit is a standard 1/4-inch stereo headphone jack. The connector is fed by the Monitor bus.

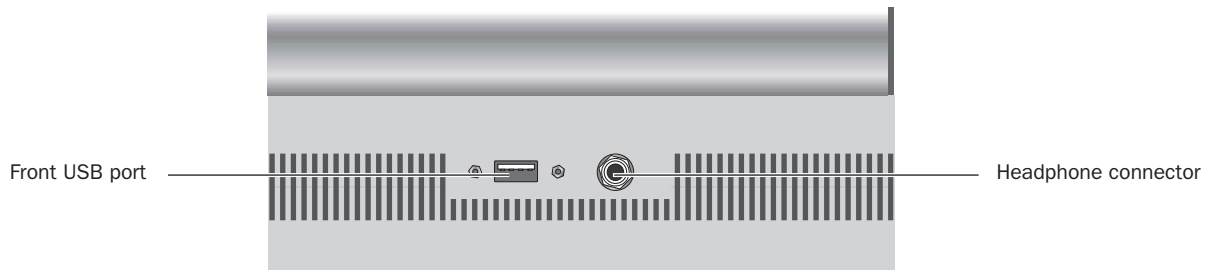

Figure 15. Main Unit front ports (under front of unit)

Main Unit Back Panel

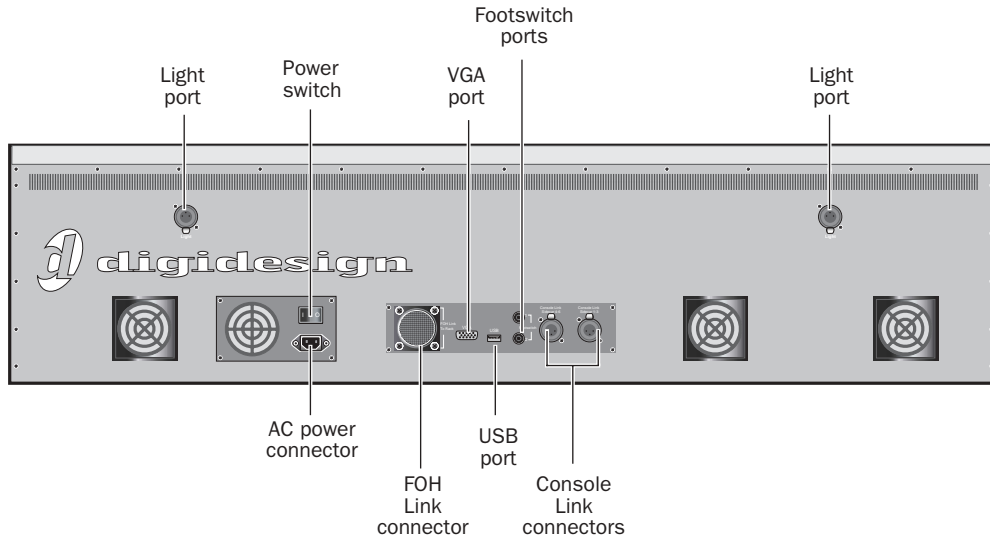

Figure 16. Main Unit back panel

Power Switch

The Power switch applies power to the D-Show Main Unit.

AC Power Connector

The AC Power connector accepts a standard AC power cable. The D-Show Main Unit is auto-power selecting (100V to 240V) and automatically works with a standard modular power cord when connected to an AC receptacle in any country.

FOH Link Connector

The FOH Link connector accepts the FOH Link cable supplied with the FOH Rack. This cable provides all the data and audio connections between the D-Show Console and the FOH Rack.

VGA Port

The VGA port accepts a standard VGA display connector for the D-Show system monitor. A 15-inch XVGA display with a minimum resolution of 1024 x 768 is recommended.

USB Port

The USB port on the back panel of the Main Unit is a USB 1.1 port. This port supports iLoks, USB key disks, and USB keyboards.

Footswitch Ports 1 & 2

The Footswitch ports on the back panel of the Main Unit are standard 1/4-inch TRS connectors. The Footswitch function is set in the Interaction tab of the Options page.

Console Link Connectors (Sidecar 1–3, 4–6)

The Console Link connectors use standard AES/EBU digital XLR cables (*not* microphone cables) to connect the Main Unit to Sidecars. Sidecars 1–3 are daisy-chained and connected to the first connector.

Sidecars 4–6 are daisy-chained and connected to the second connector.

Light Ports (2)

The two powered light ports support optional 3-pin XLR console lights.

D-Show Sidecar

Sidecar Top Panel

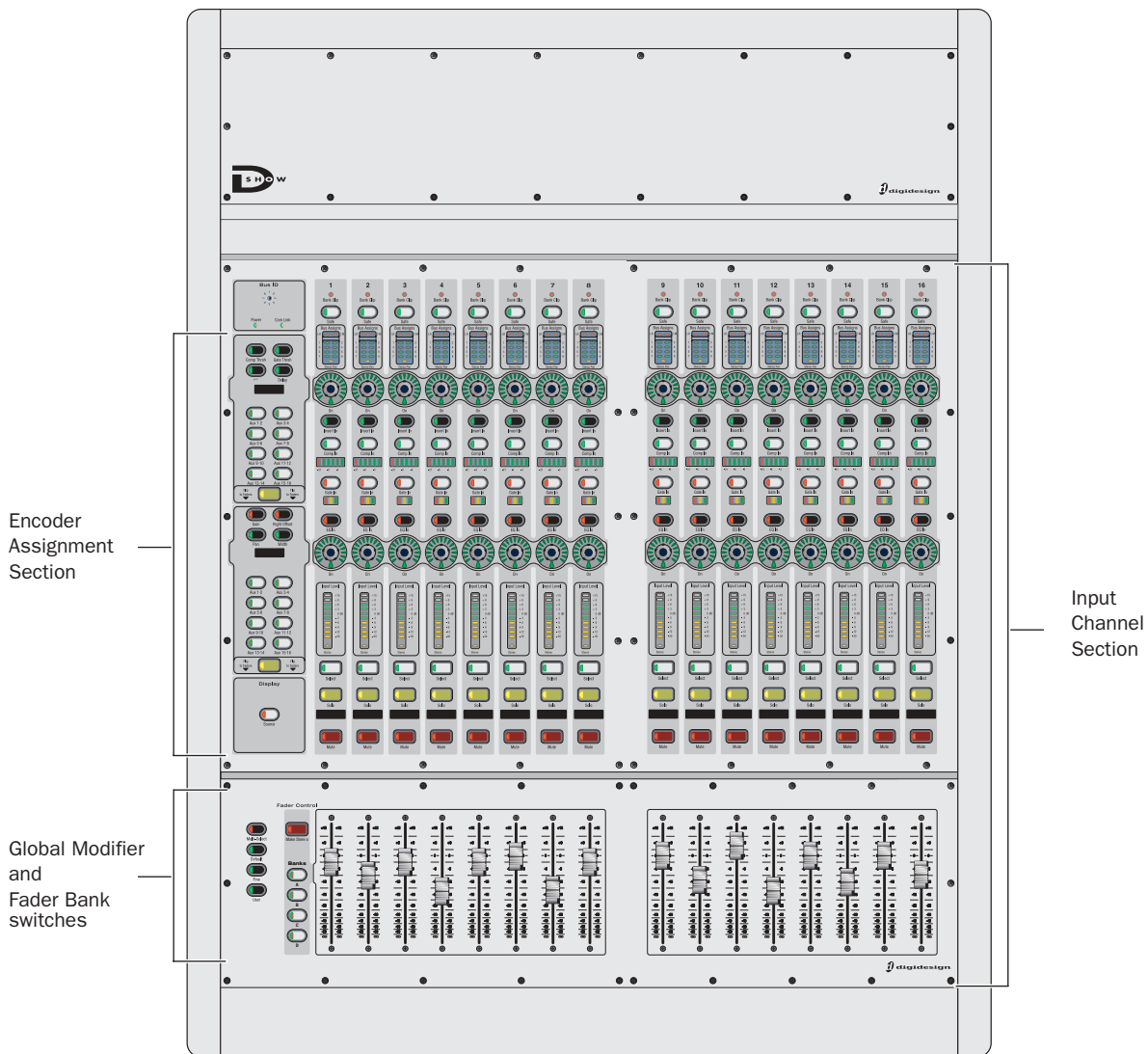

Sidecar top panel

Input Channel Section

Each D-Show Sidecar unit has 16 channel strips that provide access to Input Channels. Input Channels are used to control input signals from the Stage Rack, FOH Rack, and Pro Tools playback options.

Encoder Assignment Section

Each D-Show Sidecar unit includes Encoder Assignment controls that are used to assign functions to the two rows of rotary encoders. These controls mirror the state of the same controls on the Main Unit.

Global Modifier and Fader Bank Switches

Each D-Show Sidecar unit has a set of Global Modifier and Fader Bank switches that mirror the function of the corresponding switches on the D-Show Main Unit.

Sidecar Back Panel

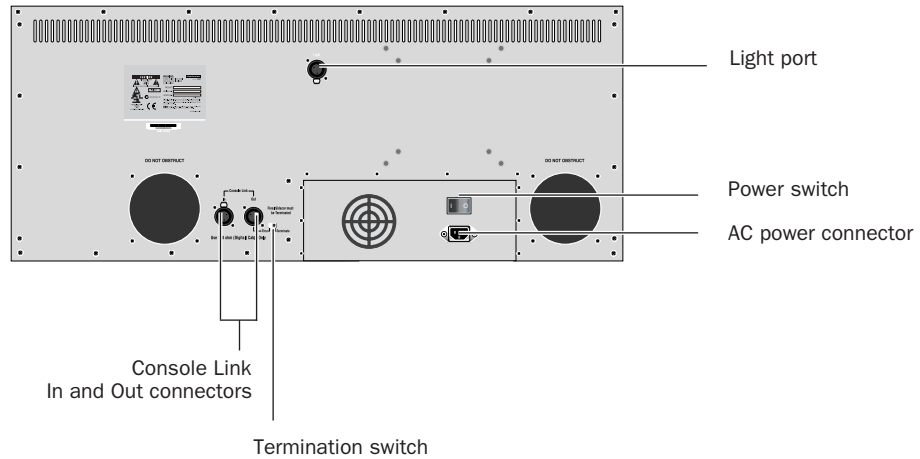

Sidecar back panel

Console Link In and Out Connectors

The Console Link In and Out connectors use 110-Ohm AES/EBU (Digital) XLR cables to connect the Sidecar to the Main Unit or to other Sidecars.

⚠ All Console Link connections require 110-Ohm AES/EBU (Digital) cable. Do not use standard audio-grade microphone cable to connect the Main Unit and Sidecars.

Termination Switch

The Termination switch is used to terminate the Console Link chain. On the last Sidecar in a chain, this switch should be set to "Terminate." On all other Sidecars, this switch should be set to "Thru."

Power Switch

The Power switch applies power to the D-Show Sidecar.

AC Power Connector

The AC Power connector accepts a standard AC power cable. The D-Show Sidecar is auto-power selecting (100V to 240V) and automatically works with a standard modular power cord when connected to an AC receptacle in any country.

Light Port

The powered light port supports an optional 3-pin XLR console light.

Chapter 29: FOH Rack Reference

FOH Rack Front Panel

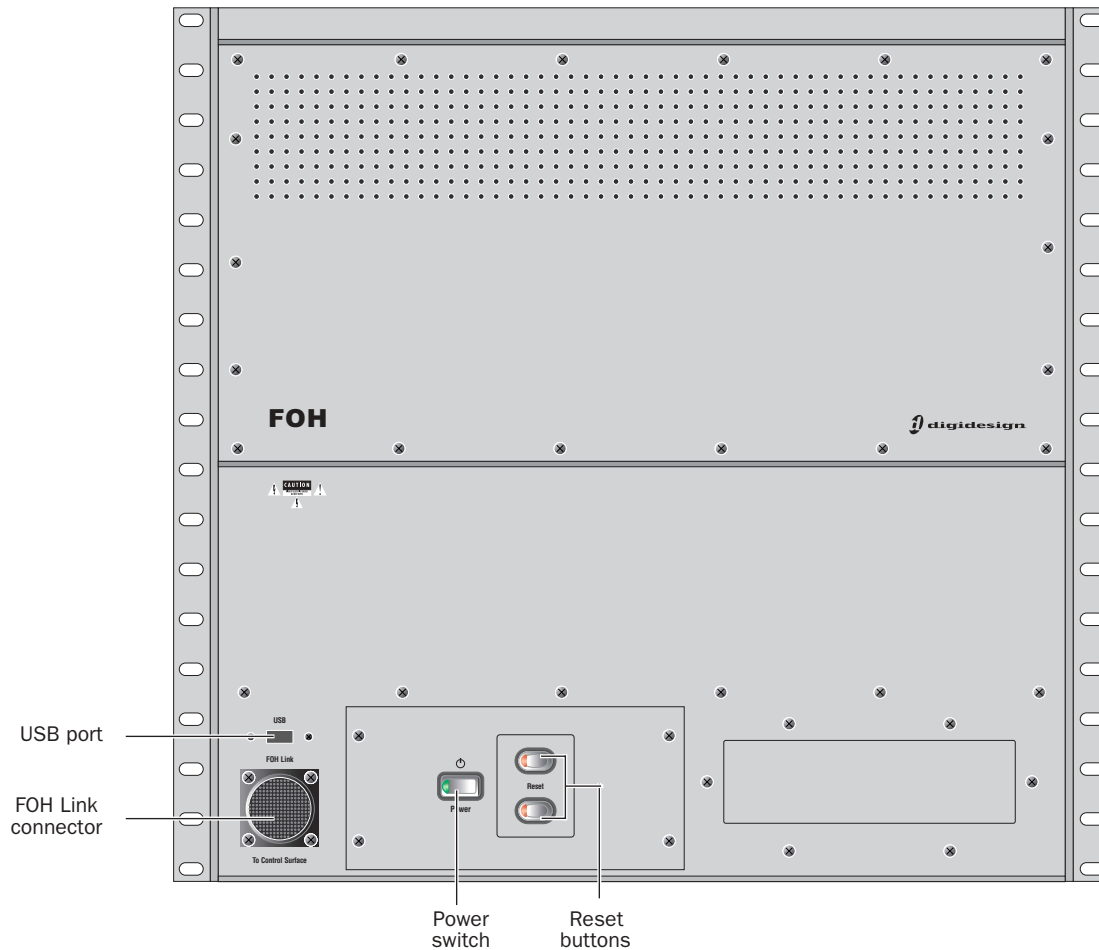

Figure 17. FOH Rack front panel

Power Switch

The Power switch applies power to the FOH Rack and starts the D-Show system.

Reset Buttons

The Reset buttons, when pressed simultaneously and held, restart the D-Show system.

FOH Link Connector

The FOH Link connector accepts the FOH Link cable that connects to the D-Show Main Unit. This cable provides all the data and audio connections between the D-Show Console and the FOH Rack.

USB Port

The USB port on the front panel of the FOH Rack is a USB 2.0 port. This port supports iLoks, USB key disks, and USB keyboards.

FOH Rack Back Panel

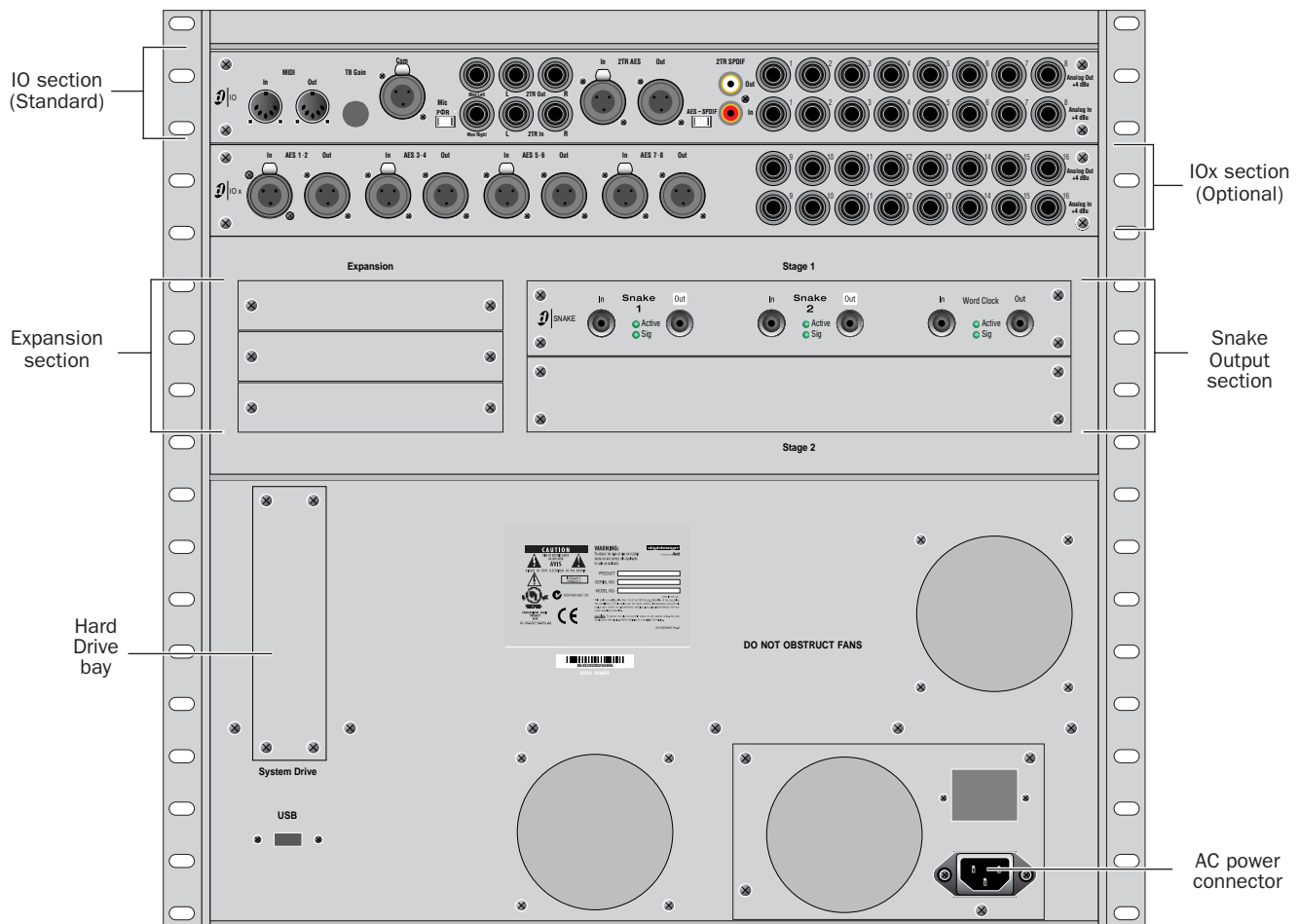

Figure 18. FOH Rack back panel

I/O Section (Standard)

MIDI I/O Ports

These MIDI In and Out Ports provide 16 channels of MIDI input and 16 channels of MIDI output to D-Show. The MIDI I/O ports are used in sending and receiving Snapshot MIDI messages, and in receiving MIDI Time Code from external devices.

Com Mic, Gain Control, and Phantom Power

This Com Mic connector and controls allow connection and control of an intercom system. The Gain control operates in steps of 3 dB. Phantom power may be applied to the Com mic with the Mic Power switch.

Monitor Outputs

These 2 Monitor Outputs are used for output to the near-field monitoring system. These are 1/4-inch balanced TRS connectors.

2-Track Analog Inputs and Outputs

These 2-Track analog connections are used for input and output of analog audio material, which can be routed to the Main bus. These are balanced 1/4-inch TRS connectors.

2-Track Digital Inputs and Outputs

These 2-Track digital connections are used for input and output of digital audio material, which can be routed to the Main bus. Stereo AES/EBU or S/PDIF I/O connectors are selectable with the AES-SPDIF switch. These connectors support 24-bit, 48 kHz digital signals. Input signals with other sample rates are sample-rate converted to 48 kHz.

Analog Inputs and Outputs (1-8)

These 8 pairs of analog inputs and outputs are used for hardware inserts, or for input and output of program material from the front of house position. These are balanced, 1/4-inch TRS connectors.

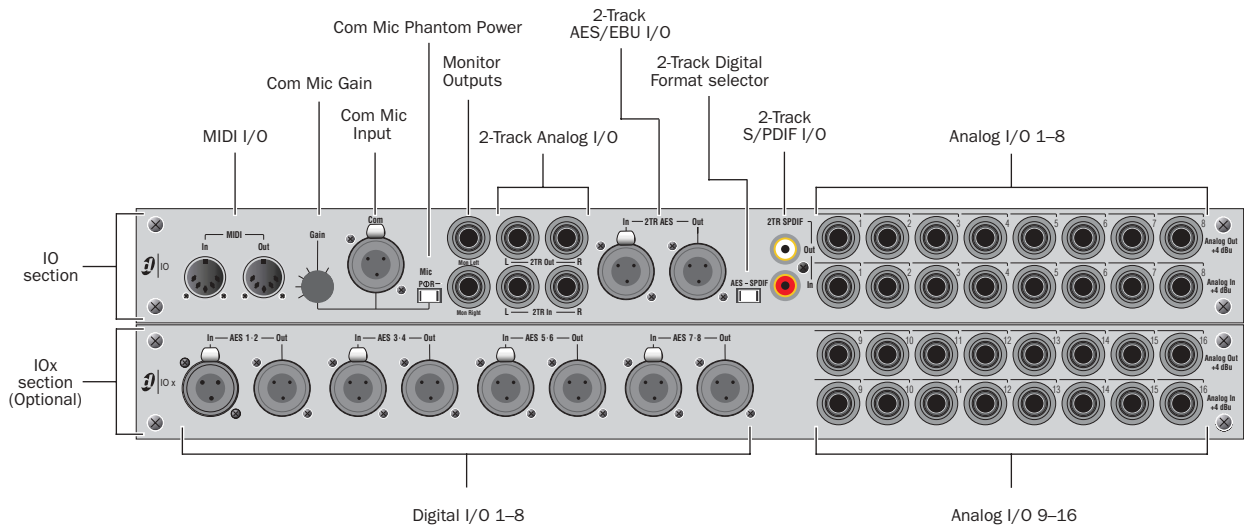

Figure 19. Audio connectors on FOH Rack, showing standard IO connectors (top) and optional IOx connectors (bottom)

IOx Section (Optional)

AES/EBU Digital Inputs and Outputs

These 4 pairs of stereo digital inputs and outputs are used for hardware inserts, or for input and output of program material at the front of house position. These connectors support 24-bit, 48 kHz digital signals. Input signals with other sample rates are sample-rate converted to 48 kHz.

Analog Inputs and Outputs (9-16)

These 8 pairs of analog inputs and outputs increase the total number of analog I/O on the FOH Rack to 16. These are balanced, 1/4-inch TRS connectors.

Expansion Section

FWx Card (Optional)

The optional FWx card enables the D-Show FWx Firewire option, which provides recording and playback of audio with Pro Tools LE.

HDx Card (Optional)

The optional HDx card enables the D-Show HDx Record and Playback option for recording and playback of audio with Pro Tools HD.

ECx Card (Optional)

The optional ECx card enables remote control of a D-Show system using wired or wireless Ethernet network equipment.

Snake Output Section

Stage 1 (Standard)

The Snake card accepts the Digital Snake cable (Snake 1) and an optional redundant cable (Snake 2) that connects the FOH Rack to the Stage Rack, handling up to 48 channels of audio.

Stage 2 (Optional)

An optional second Snake card may be added to the FOH rack to enable the use of a second Stage Rack, increasing capacity to 96 channels of audio. The second Snake card also supports an optional redundant cable.

Snake Connectors

The FOH Rack Digital Snake connectors consist of two pairs of BNC-style connectors (Snake 1 In and Out, Snake 2 In and Out), and two pairs of signal status indicators.

Active LED Green LED lights to indicate that connection to FOH Rack is active for the corresponding Snake. Only one Snake can be active at a time.

Sig LED Green LED lights to indicate that signal is present on the corresponding Snake.

All Snake LEDs flash when no Snake signal is present.

USB Ports

The FOH Rack has one external and one internal USB port. Both are USB 2.0 ports that support iLoks, USB key disks, and USB keyboards.

Connector Pinouts

FOH Link cable VGA BUNDLE pinouts

P1	VGA BUNDLE	P2
U	RED DATA	U
A	GREEN DATA	A
T	BLUE DATA	T
V	ID	V
B	RED GND	B
S	GREEN GND	S
n	BLUE GND	n
W	GND	W
C	ID	C
m	ID	m
p	HSYNC	p
X	VSYNC	X
k	VGA SHIELD	k

FOH Link cable RACK BUNDLE pinouts

P1	RACK BUNDLE	P2
HH	RACK PSU	HH
BB	RACK GND	BB
CC	RACK SHD	CC
DD	SPR 1	DD
GG	SPR 2	GG

FOH Link cable TALKBACK BUNDLE pinouts

P1	TB BUNDLE	P2
R	TB P	R
j	TB N	j
y	TB GND	y
P	TB SHEILD	P

FOH Link cable HEADPHONE BUNDLE pinouts

P1	HP BUNDLE	P2
N	HP L	N
i	HP R	i
h	HP GND	h
M	HP SHEILD	M

FOH Link cable CAN BUNDLE pinouts

P1	CAN BUNDLE	P2
Y	CAN 1 H	Y
r	CAN 1 L	r
Z	CAN 2 H	Z
s	CAN 2 L	s
a	CAN 3 H	a
b	CAN 3 L	b
E	CAN 4 H	E
F	CAN 4 L	F
D	CAN CS	D

FOH Link cable USB BUNDLE pinouts

P1	USB BUNDLE	P2
K	USB 5+	K
J	USB GND	J
H	USB D+	H
d	USB D-	d
G	USB SHIELD	G
f	USB +5	f
c	USB GND	c

Not connected: AA, FF, z, x, w, v, u, t, q, e, L, g

Chapter 30: Stage Rack Reference

Stage Rack Front Panel

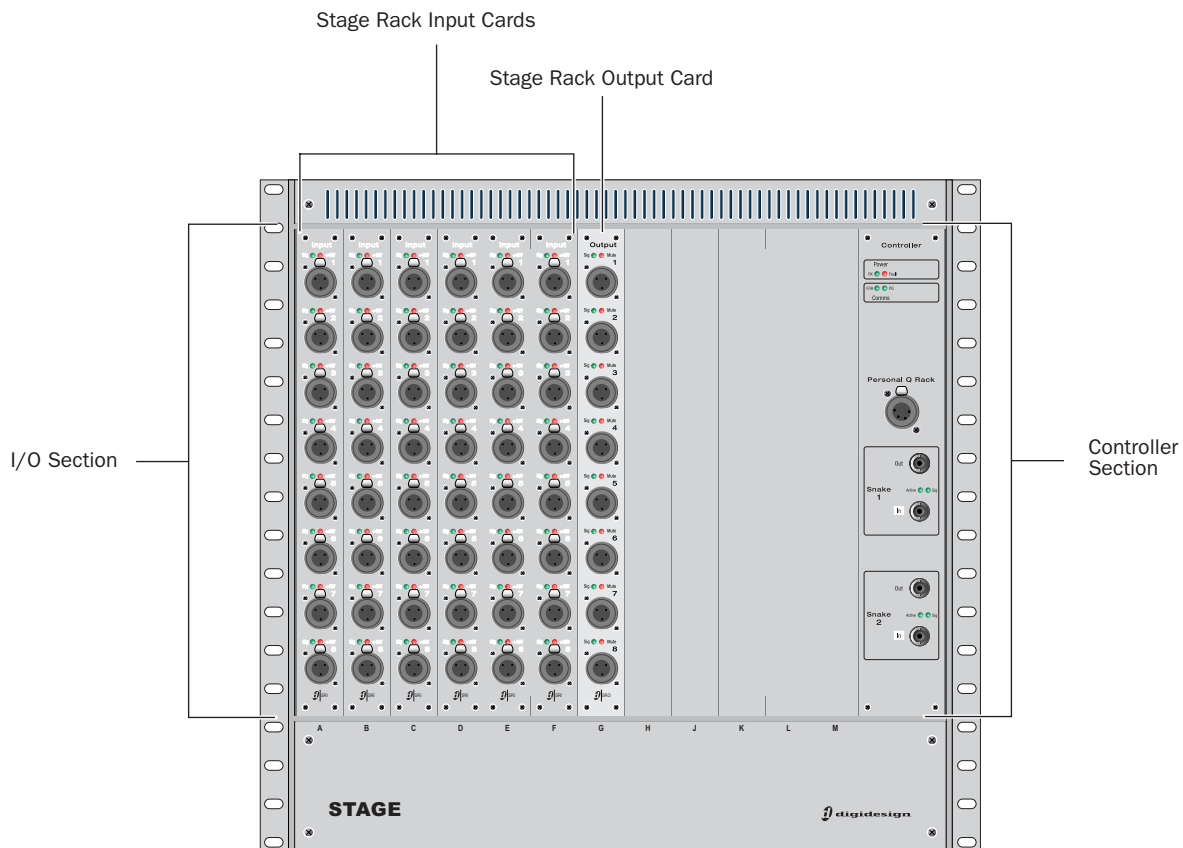

Figure 21. Stage Rack front panel

Stage Rack I/O Section

The Stage Rack I/O section consists of 12 slots that accept modular input cards or output cards. The first 6 slots (A–F) of the Stage Rack accept input cards only (such as SRI and DSI cards). The last 6 slots (G–M) accept output cards only (such as SRO and DSO cards).

Stage Rack Input Cards

Each SRI card has 8 analog inputs. The connectors are female XLR connectors. Each Input connector has Signal Present and Phantom Power LED indicators.

Stage Rack Output Cards

Each SRO card has 8 analog outputs. The connectors are male XLR connectors. Each Output connector has Signal Present and Hardware Mute indicators.

Outputs are automatically muted when the system restarts. Outputs can also be muted with a footswitch command.

Digital Stage Input Cards

(Optional)

Each DSI card has 8 digital input channels (8 female AES3 connectors and a single ADAT (Optical) input connector). Input source is selectable in software. Inputs have Lock and SRC OFF (sample rate conversion) LEDs, and additional LEDs indicate input source (AES or ADAT). DSI cards also provide Word Clock Out.

Digital Stage Output Cards

(Optional)

Each DSO card has 8 digital output channels (8 male AES3 connectors and a single ADAT (Optical) output connector). Both banks of outputs (AES and ADAT) are active at all times. LEDs indicate signal and mute status.

Outputs are automatically muted when the system restarts. Outputs can also be muted with a footswitch command.

Stage Rack Controller Section

The Stage Rack Controller section includes power and communication status indicators, Personal Q Rack connector, and Digital Snake connectors.

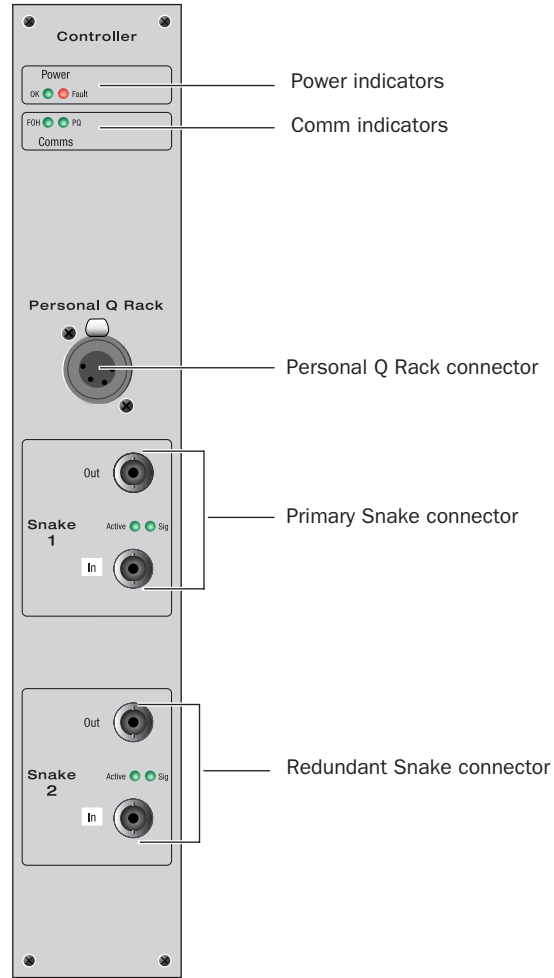

Power Indicators

OK LED Green LED lights to indicate that power and fan signals for at least one Stage Rack power supply is good.

Fault LED Red LED lights to indicate that any power or fan signal for a Stage Rack power supply is not good.

Comm Indicators

FOH LED

- ◆ Flashing fast means Stage Rack processor is OK and is receiving data from FOH
- ◆ Flashing slow means Stage Rack processor is OK but is also not receiving data from FOH
- ◆ Full on or off means Stage Rack processor is stuck.

PQ LED

- ◆ Flashing means that messages are being received from the PQ Rack and PQ Controllers
- ◆ No flashing indicates that there is no active link between PQ Rack and the Stage Rack.

Personal Q Rack Connector

The Personal Q Rack Connector is a special 4-pin XLR connector that accepts the PQ Rack cable supplied with the PQ Rack unit.

Snake Connectors

The Stage Rack Digital Snake connectors consist of two pairs of BNC-style connectors (Snake 1 In and Out, Snake 2 In and Out), and two pairs of signal status indicators.

Active LED Green LED lights to indicate that connection to FOH Rack is active for the corresponding Snake. Only one Snake can be active at a time.

Sig LED Green LED lights to indicate that signal is present on the corresponding Snake.

All Snake LEDs flash when no Snake signal is present.

Stage Rack Back Panel

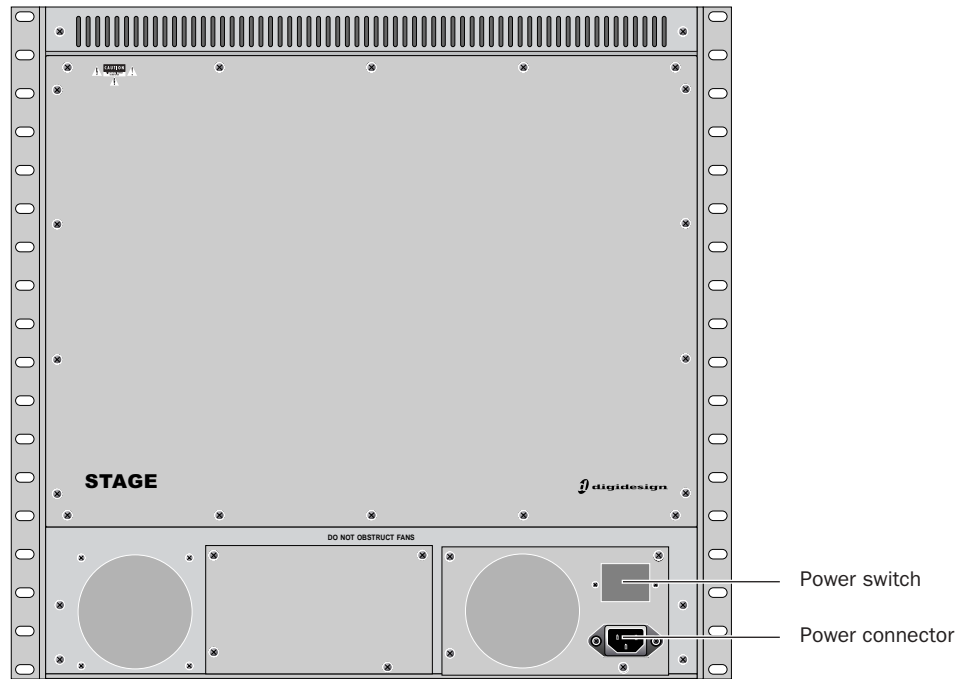

Figure 22. Stage Rack back panel

Power Switch

The Power switch applies power to the Stage Rack.

AC Power Connector

The AC Power connector accepts a standard AC power cable. Stage Rack power supplies are auto-power selecting (100V to 240V) and automatically work with a standard modular power cord when connected to an AC receptacle in any country.

Index

Numerics

1–8 (Bus LED) 25
2-Track 53
48V 13
4M- 217

A

A Unit has gone Offline 216
Absolute (editing snapshots) 180
ACS
 target and channel Select switch 27
 targeting options 54
ACS (see also Assignable Channel Section)
ADAT 14
Add (or Update) this plug-in to Snapshot 158
AES/EBU
 Console Link cables 5
AES3 14
All (snapshots) 171
APAN 26
Assignable Channel Section 28
Assignable Output Encoders 29
 and plug-ins 155
 banking 40
Assignable Output Faders 30
attack
 compressor/limiter 125
 expander/gate 126
automation 175
 see Snapshots
Automation Safe 54
auto-save and History 168
AUX 26
Aux
 banking 41
 busses 83
 configuring busses and Groups 70
 linking 70
Aux Sends
 snapshot as monitor, or as effects sends 188

B

backup
 and History 168
 CD-ROM 216
balance (when pasting) 44
ballistics for meters 54, 107
bandwidth
 EQ 134
Bank A–D 39
banking 39
 main and sidecar split banking 39
 outputs 41
banner display 33
bell or shelf EQ 134
blue (snapshot) 173
built-in
 compressor 125
 expander 125
 gate 125
 limiter 125
bus assignment indicators 25
Bus ID 8

bus processors
 assigning plug-ins 153
busses
 Aux and Variable Group linking 70
Busses page 50
bypass
 EQ in out 133
bypassing plug-ins 151

C

C/M
 LED 25
Cancel 31
CD-ROM
 using for Transfer and Filing 197
Change Target By 54
channel
 reset shortcut 44
Channel Name 27, 55
channel number (plug-in rack routing) 151
CHANNEL SAFE 177
channels
 banking 39
 configuring number of 48
 copy and paste 44
 in the Patchbay 99
 layout and numbering via Bus ID 8
 moving 45
 selecting 41
 type text search 42
Chase MTC 172
Clear 170
Clear Console
 during reset 215
Clear Solos
 footswitch options 54
clip
 Hold 107
 Margin 107
clock
 system date and time 53
clock (word) 15
colors in rack slots 150
COMP 26
comp knee
 compressor/limiter 125
Comp/Lim 128
compressor
 side-chain 130
compressor/limiter
 adjusting 127
 attack 125
 comp knee 125
 defaults 126
 Dynamics Graph 129
 gain reduction meters 126
 make-up gain 125
 ratio 125
 release 125
 threshold 125
Config Mode 34
 and plug-ins 145
Console Config 34
console lights 54

- Console Link cables 5
- Console Mode (Config versus Show) 34
- Control Surface Change 213
- Control Surface options 55
- controls
 - input and FX return channels 24
- copy and paste
 - channel settings 44
 - dynamics settings 130
 - EQ settings 139
- copying
 - plug-ins 152
- Create new snapshot containing this plug-in 158
- crossfade time (snapshots) 187

D

- Date & Time Check 213
- date and time 53
- Default 34
 - while unlinked 39
- defaults
 - compressor/limiter 126
- DELAY 26
- delay
 - compensation 75
 - mains (house) 75
 - Monitor bus 114
- Delete (snapshots) 170
- Devices page 50
- digital
 - AES, ADAT 14
 - gain and HDx 16
 - sample rate conversion 15
- Digital/Analog EQ 133
- DigiTest 215
- Dim
 - Talkback dim 53
- Direct Outs
 - from output busses 76
 - pickoffs for 101
 - routing to plug-ins 154
- Disable
 - snapshots 170
- divergence 75
- Dly (channel Delay in snapshots) 189
- D-Show
 - Standalone software 195
- DSI card (Digital Stage Input) 14
- DSO card (Digital Stage Output) 14
- DSP
 - plug-in allocation tips 48
 - plug-ins 159
- Duplicate 170
- Dyn Pre-EQ 127, 134
- dynamics
 - adjusting 127
 - and plug-ins 129
 - comp/lim 126
 - Dynamics Graph 129
 - output LED 30
 - plug-ins 157
 - presets for built-in 130
 - reset 128
 - settings and presets 129
 - side-chain 130

E

- Edit (System Config) 47
- Edit mode 180
- encoders
 - split banking 39
- EQ
 - adjusting 135
 - and plug-ins 138
 - bell or shelf 134
 - built-in HPF 133
 - built-in parametric 133
 - bypass via Input Direct mode 127, 134
 - digital/analog 133
 - Dyn Pre-EQ 127, 134
 - GEQ 73
 - in out 133
 - output LED 30
 - parametric 133

- plug-ins 157
- ranges of controls 140
- settings and presets 138
- Exp/Gate 128
- expander
 - side-chain 130
- Expander/Gate
 - threshold 126
- expander/gate
 - adjusting 127
 - attack 126
 - gain reduction meters 126
 - gate range 126
 - release 126

F

- faders
 - Flip 26
 - Mains (house) 31
 - reset shortcut 44
 - split banking 39
- Filing
 - History 168
 - loading Shows 164
 - Presets and Scope Sets 165
 - Show files 164
 - Show Folders 163
- filtering with Recall Safe 175
- Fine 35
 - momentary or latching 35
 - while unlinked 39
- firmware 217
- Flip 26
- Footswitch
 - functions for 1 and 2 54
- formats (plug-ins) 152
- Function switches (F1, F2, F3, F4) 31
- FX Returns
 - and plug-ins 154
 - banking 39
 - channel controls 24
 - configuring 48

G

- gain
 - and multiple input routing 101
 - digital gain and HDx 16
 - Guess 26
 - setting 26
- GATE 26
- gate
 - key source 130
 - range for expander/gate 126
 - side-chain 130
- global modifiers 34
- Graphic EQs 73
 - configuring 48, 137
- green (snapshot) 173
- Groups
 - and Variable Groups 70
 - banking 41
 - linking Var Groups 70
 - using 79
- Guess (gain) 26

H

- hard knee 125
- hardware
 - display of unavailable 98
- HDx
 - and digital gain 16
- headphones
 - level 113
- hexadecimal 186
- high-pass filter 133
- History 168
- house (Mains)
 - fader 31
 - mute 120
- HPF 26

I

- I/O
 - unavailable 98
- iLok 147
 - USB ports 148
- In/Out
 - EQ 133
- INP GN 26
- Input channel numbering 8
- Input Channels and Faders 24
- Input Direct mode 127, 134
- inputs
 - analog 13
 - automation safe 178
 - channel controls 24
 - connecting digital 15
 - digital 14
 - input channels and FX returns 24
 - Input Direct mode 127, 134
- Insert Mode 155
- insert number (plug-in rack routing) 151
- inserts
 - assigning plug-ins 153
 - on outputs 72
 - output LED 30
 - routing in the Patchbay 102
- Installed Plug-Ins 145
- Interaction page 53
- invert output phase 74

K

- key assign 130
- key listen 131
- key source 131
- knee
 - hard or soft 125
- knobs
 - rotary and switch functionality 25
 - see encoders

L

- LCDs
 - options 55
- LCR 49
- levels
 - plug-ins 159
- limiter
 - adjusting 127
 - defaults 126
 - side-chain 130
- linking
 - Auxes and Variable Groups 70
 - screen and console 33, 54
- LR
 - LED 25

M

- Main 49
- Main busses
 - configuring 49
- Main Unit 23
 - split banking 39
- Mains (house) fader 31
- maintenance
 - system restore 216
- Make Stereo/Mono
 - shortcut 45
 - while unlinked 39
- make-up gain
 - compressor/limiter 125
- Masters and Global section 31
- Matrix
 - banking 41
 - linking and unlinking inputs 94
- Meter Bridge 32
- metering 103
 - ACS 104
 - ballistics and options 107
 - Bank Clip 104
 - channel meters 103
 - outputs 106
 - Selected Channel 105
 - solo 106

MIDI

- adding to snapshots 185
- and Recall Safe 176
- in Preview mode 184

Misc page 53

- Mix Engines 48
- modes (Config versus Show) 34
- Mon (Aux sends and Variable Groups) 188

Monitor

- assignable output 113
- Delay 114
- level 113

More Options (during resume) 215

Move Selected Strip Here 45

moving plug-ins 152

MTC

- chase 172
- configuring options 52
- in Preview mode 184

Multi 34

- Multi-Assign 42
- Multi-Select 34
 - while unlinked 39

Mute

- footswitch options 54
- Groups 120
- input and FX inputs 119
- Mains (house) 120
- outputs 75, 119

N

- name (channel display) 27
- navigating 39
- near-field levels 113
- New 170
- next (snapshot) 172
- noise 53
- None (snapshots) 171
- Notes (snapshots) 174

O

- Offline 216
- On (Recall Safe) 176
- One or More Units have Failed 212
- operating modes 34
- Options 47
 - Busses 50
 - Control Surface interaction 55
 - Devices 50
 - Interaction 53
 - Misc 53
 - Pickoffs 52
 - Plug-Ins 145
 - Snapshots 52
 - System Config 47
 - viewing angle 55
- oscillator
 - settings 53
- Other 152
- outputs
 - analog 13
 - and mute 119
 - automation safe 178
 - banking 40
 - configuring 69
 - delay 75
 - digital 14
 - divergence 75
 - graphic EQ 73
 - metering 106
 - mute 75
 - reassigning in Patchbay 102
 - routing 71
 - using inserts 72

P

- pan
 - divergence 75
 - when pasting 44
- PANBAL 26
- panning
 - 3-across-the-front 49
- parametric EQ 133

- Patchbay
 - and inserts 102
 - displays and indicators 98
 - navigating 99
 - overview 97
 - route multiple via click and drag 100
 - source and destination display 99
 - warning when reassigning 102
- Patching Grid 98
- Peak Hold 107
- Peak mode (metering) 107
- phantom power 13
- phase (output) 74
- Pickoffs page 52
- Pink Noise 53
- Plug-In Racks are Ready 215
- Plug-In Racks Need Reset 215
- plug-ins 145
 - allocating DSP 48
 - and channel Direct Outs 154
 - and Recall Safe 176
 - and snapshots 158
 - and standalone software 195
 - assigning to rack slots 152
 - Config and Show mode 145
 - display unavailable and inactive 150
 - dynamics 157
 - enabling and disabling 148
 - EQ 138, 157
 - in Preview mode 184
 - in/out (bypass) 151
 - managing 146
 - mono, stereo, other 152
 - moving and copying 152
 - on outputs 72
 - on the control surface 155
 - on-screen 156
 - pinning a view 156
 - preset files 157
 - rack slots 150, 151
 - racks 149
 - re-initializing the racks 215
 - routing to and from 153
 - targetting 155
 - Use Racks 215
 - views 149
- Plug-ins to Install 145
- polarity (output) 74
- power
 - start up/shut down guidelines 19
- Power Supply Alert 213
- PQ
 - banking 41
 - linking and unlinking inputs 94
- Pre (snapshot parameters) 188
- presets
 - dynamics 129
 - EQ 138
 - folders 165
 - for built-in dynamics 130
 - managing 166
 - plug-ins 157
 - Scope Sets 178
 - transferring 167
- Preview mode 182
 - and plug-ins 184
 - and Undo 183
 - capabilities and overview 183
 - MIDI and MTC 184
- previous (snapshot) 172
- Propagate mode 181
- Push-Pin (plug-in view) 156

Q

- Q 134

R

- rack slots 149
- racks 215
- racks (plug-ins) 149
- ratio
 - compressor/limiter 125
- Ready to Resume 214
- Recall 170, 174
 - Next 172
 - Previous 172
 - Safe 175
- Recall Safe 175
 - and MIDI 176
 - and plug-ins 176
 - and Preview mode 183
 - CHANNEL SAFE 177
 - turning on and off 176
 - using 177
- recovery 215
- red (snapshot) 173
- Relative (editing snapshots) 180
- release
 - compressor/limiter 125
 - expander/gate 126
- Remove this plug-in in Snapshot 168
- Reset 215
- reset 214
 - dynamics 128
- Reset (strip) 44
- reset a section or parameter 34
- Reset Fader 44
- Reset Mix Engines 215
- resolution (see Fine)
- restart 214
- restore (software) 216
- Resume Operations 214
- RGHTGN 26
- right-click shortcuts 44
- RMS mode 107
- rotary encoders
 - rotary and switch functionality 25
- routing
 - channel bus indicators 25
 - in the Patchbay 100
 - Monitor bus 113
 - multiple D-Show channels to a hardware output 101

S

- Safe
 - Automation 54
 - Recall Safe 175
 - Solo 54
 - using channel automation safe 178
- Safe All 178
- Safe Selected 178
- Sample rate conversion 14
- save (History auto-save) 168
- Scope Sets
 - transferring 167
 - using 178
- Select
 - channel switch 27
- selecting channels 41
- settings
 - dynamics 129
 - EQ 138
 - plug-ins 157
- shelf or bell EQ 134
- shortcuts 34
 - right-click 44
 - Snapshots 173
- Show files 163
 - creating 163
 - deleting 163
 - Folders 163
 - loading 164
 - transferring 167
- Show Folder 163
- Show Mode 34
- Sidecar 23
 - split banking 39
- side-chain 130
 - assigning for plug-ins 154
 - assigning source (gate only) 130

- signal routing
 - display in Patchbay 99
- Snapshots
 - adding MIDI messages 185
 - adding plug-in data 186
 - All 171
 - Channel Safe 177
 - channel scope 170
 - chase MTC 172
 - classifying Auxes and Var Groups 188
 - Clear 170
 - color indication in List 173
 - creating 173
 - crossfade time 187
 - data type buttons 170
 - Delete 170
 - Disable 170
 - Duplicate 170
 - Edit mode 180
 - faders 171
 - footswitch options 54
 - from the console 171
 - in Preview mode 183
 - keyboard shortcuts 173
 - List 170
 - list of data types and parameters 189
 - managing (storing, clearing, deleting, moving, duplicating) 179
 - MIDI and plug-ins in Preview mode 183
 - naming and renaming 174
 - New 170
 - Next 172
 - None 171
 - notes 174
 - overview 169
 - plug-in menu 158
 - Preview (editing and previewing snapshots) 182
 - Previous 172
 - Propagate mode (updating snapshot parameters) 181
 - Recall 170
 - Recall Safe 175
 - recalling 174
 - safe filter (Recall Safe) 177
 - Scope Sets 178
 - selecting 173
 - Store 170
 - target 174
 - type text search 42
 - x-Fade 187
- Snapshots containing this plug-in 158
- Snapshots page 52
- soft knee 125
- software
 - overview of pages and tabs 36
 - standalone 195
 - system restore 216
 - updating 216
- Solo
 - and key listen 131
 - metering 106
 - on-screen settings 51
- Solo Safe 54
- Source 27
- Stage Rack
 - enabling 2 19
- standalone software 195
 - and plug-ins 195
 - installing and removing 195
 - system requirements 195
- stereo plug-ins 152
- Store 170
- synchronizing digital sources 15
- system clock 53
- System Config 47
- System Update and Restore CD 216

T

- takeover from backup mode 214
- Talkback
 - and footswitch 54
 - dim level 53
- target
 - channel Select switch 27
 - channels 41
 - plug-in 155
- Targeting Changes View Mode 54
- threshold
 - compressor/limiter 125
 - Expander/Gate 126
- Tool Tips 33
- Trackball 32
- transfer 167
- troubleshooting
 - plug-ins 148
 - restore and replace all software 216
- Type Text search 42

U

- Undo
 - in Preview mode 183
 - via History 168
- Update this plug-in in Snapshot 158
- updating D>Show software 216
- USB
 - ports for iLoks 148
- Use Racks 215
- User 35

V

- Variable Groups 69
 - snapshot as monitor, or as effects sends 188
- Variable Sine 53
- VCAs
 - and snapshots 189
 - assigning 77
 - banking 41
 - mute 119
 - using 77
- View Modes 32

W

- White Noise 53
- WIDTH 26
- width (when pasting) 44
- word clock 15

X

- X-fade (crossfade) 187

Y

- yellow (snapshot) 173

Z

- zero
 - see Clear Console



www.digidesign.com

DIGIDESIGN

2001 Junipero Serra Boulevard
Daly City, CA 94014-3886 USA
Tel: 650.731.6300
Fax: 650.731.6399

TECHNICAL SUPPORT (USA)

Tel: 650.731.6100
Fax: 650.731.6384

PRODUCT INFORMATION (USA)

Tel: 650.731.6102
Fax: 800.333.2137

INTERNATIONAL OFFICES

Visit our Digidesign Web site
for contact information