

ARENA PRO



Passive speakers

ARENA PRO Serie

The ARENA PRO series is a line of passive speaker cabinets comprising four high-quality two-way enclosures loaded with 1" and 1.4" compression drivers, as well as two high-performance subwoofers. Equipped with an extensive feature set, these enclosures are well-suited for diverse mobile applications and fixed installations. All mid-/high-range units come in a multifunctional multiplex housing equipped with a pole mount, a slanted rear panel enabling convenient monitoring, and up to twelve professional-grade M8 or M10 rigging points.

Loaded with high-quality speakers made of Premium RCF® components and ND series neodymium compression drivers, all models are engineered to handle considerable loads, deliver high sound pressure levels, and satisfy professional demands. They also sport aluminum CD (constant directivity) high-frequency horns designed especially for this line. Shaped symmetrically to enable 90° rotation, these horns are adjustable, easily aligned to suit the given sound reinforcement situation.

Remarkably light and equipped with ergonomic grips handles, these cabinets are easily handled. Coated with robust black textured paint, all models also sport a rugged grille backed with acoustic foam rubber.



Versatile and robust

- ▶ High-quality multifunctional housings made of multiplex coated with a rugged black textured finish
- ▶ Professional-grade M8/M10 threaded rigging points
- ▶ Professional Speakon connectors, Parallel Output included
- ▶ Protective cover included (ARENA 8/10/12/15 PRO)
- ▶ Subwoofer's threaded M20 base ready to accept a pole mount

High-quality RCF® speaker components

- ▶ Rotatable high-frequency, wide-dispersion horns painstakingly engineered for excellent directivity and made of aluminum to keep drivers cool
- ▶ RCF PRECISION woofer with double voice coils (excepting the 8" model) for highest load-handling and minimum power compression; the SW 18 PRO also features a neodymium magnet
- ▶ RCF PRECISION neodymium high-frequency Direct Drive driver and high-quality tweeter cones made of Mylar or titanium
- ▶ High-quality passive voice crossovers featuring PTC tweeter protection
- ▶ With Dynamic Horn Processing DHP™ Bi-Amp performance of Arena 12 and 15 PRO is achieved with only one amplifier channel. This reduces costs, rackspace and controlling.

Easy mounting and transport

- ▶ Professional accessories optionally available
- ▶ Subwoofer ready to accept professional-grade casters

ARENA 8 PRO 8"/1" two-way loudspeaker

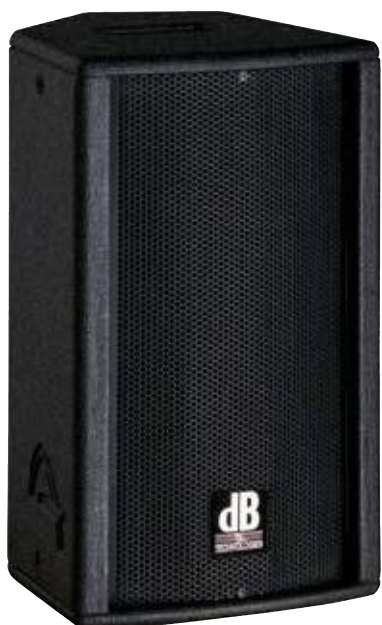

The ARENA 8 PRO is an exceedingly compact yet surprisingly powerful speaker designed to render speech and background and other music. Loaded with a high-quality 8" RCF woofer and a 1" RCF neodymium compression driver with a rotatable aluminum 90° x 70° CD horn, it is very articulate, providing great speech intelligibility despite its compact dimensions and light weight of just 10.9 kg.

This enclosure is rated for 300 watts RMS nominal power-handling capacity, 125 dB maximum SPL, and 8 ohms impedance. Two Speakon connectors are available, one of which may be used as a parallel output.

Made of multiplex coated with a robust black textured finish, the multifunctional housing is equipped with a grip on the top panel, a pole mount, and 12 M8 rigging points. A stable metal grille backed with laminated acoustic foam rubber protects the speakers.

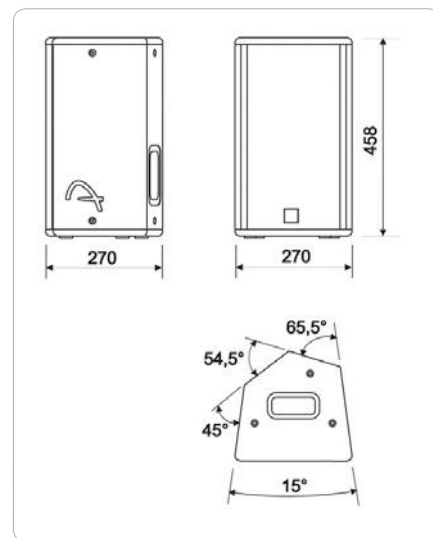
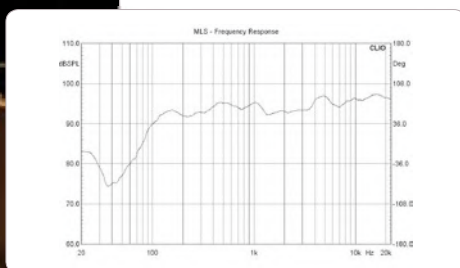
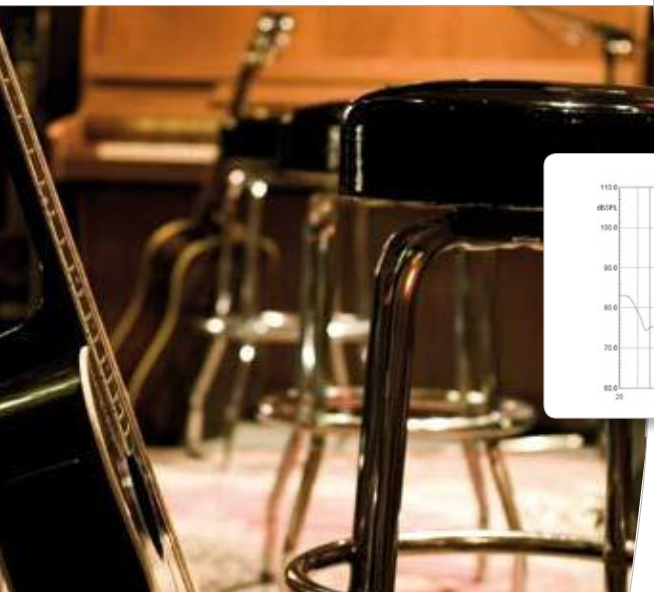

ARENA 8 PRO Technical data

► Audio data

Power handling (nominal)*:	300 W RMS
Power handling (program):	600 W
Power handling (peak):	900 W
Impedance:	8 ohms
Sensitivity 1W@1m:	94 dB
Max SPL:	125 dB
Frequency response -10 dB:	75 Hz - 20 kHz
Frequency response +3 dB:	100 Hz - 19 kHz
Low/mid woofer:	8" RCF, 2" voice coil
High frequency driver:	1" RCF neodymium compression driver, 1.5" voice coil
High frequency protection:	PTC
Horn:	90° x 70°, rotatable aluminum horn
Crossover frequency:	1800 Hz, 18 dB/octave

► Hardware

Enclosure:	Multiplex, structured black paint
Handles:	One top-mounted grip
Pole mount:	36 mm
Angles up:	45° for monitor applications
Grille:	Metal backed with acoustic foam rubber
Connectors:	Two Speakon NL 4s, pin 1+ = +, 1- = -
Rigging points:	Twelve M8 threaded shafts
Dimensions (W x H x D):	270 x 458 x 270 mm, 10.63" x 18" x 10.63"
Weight:	10.9 kg, 23.98 lbs
Optional accessories:	WB A810 pivoting wall mount bracket WB A08 U wall mount TE M8 eyebolt set

* RMS when operated in the range of 20Hz to 20kHz; pink noise spectrum; peak power handling measured over two hours with a +6 dB crest factor

Accessories & applications

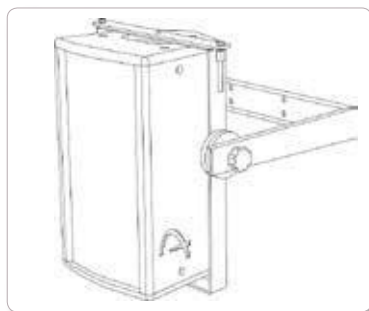

- ▶ WB A08 Arena 8 PRO Wall Mount
- ▶ WB A10 Arena 10 PRO Wall Mount
- ▶ WB A12 Arena 12 PRO Wall Mount
- ▶ WB A15 Arena 15 PRO Wall Mount
- ▶ WB A810 Arena 8/10 PRO Wall Mount, pivoting
- ▶ TE M10: Set with three rigging eyebolts with M10 thread
- ▶ TE M8: Set with three rigging eyebolts with M8 thread



- ASX18**
- ▶ Active two-way crossover
 - ▶ Variable crossover frequency
 - ▶ 2 x XLR/ Jack input
 - ▶ 2 x HF XLR output
 - ▶ 2 x LF XLR output

Applications

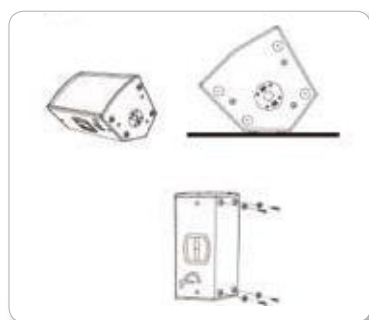

- ▶ **As a stage monitor**
Four more rubber feet may be attached to the slanted panel for monitoring purposes.



- ▶ **As a fullrange system**
on a speaker stand

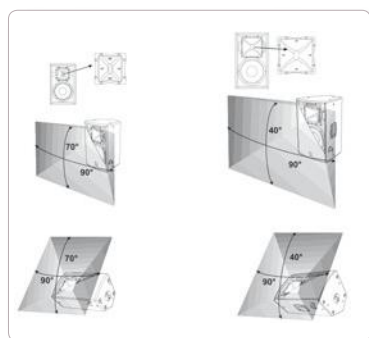

- ▶ **Rotable CD-horns**
ARENA PRO speakers feature excellent high-frequency, constant directivity horns designed especially for this line. Shaped symmetrically, these horns may be rotated 90° to align them suit the given requirements.

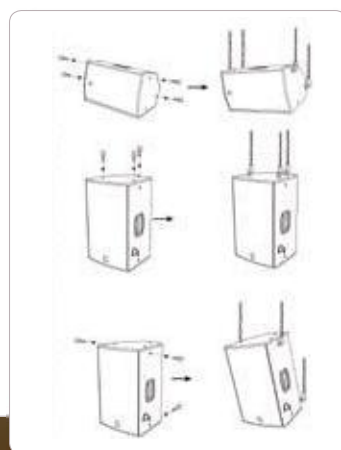

- ▶ **Flown**

