

Q-Series

Rigging manual (1.2EN)

Z5159 Q Flying frame
Z5156 Q Flying adapter

**WARNING!**

This refers to a potentially dangerous situation which may lead to personal injury.

CAUTION!

This refers to a potentially dangerous situation which may lead to damage to the equipment.

IMPORTANT!

This refers to a situation which may cause the equipment to malfunction.

Note:

Additional information and/or references.

Symbols on the equipment

Please refer to the information in the operating manual.

General Information

Q-Series
Rigging manual

Version 1.2EN, 02/2007, D2951.E.01

Copyright © 2007 by d&b audiotechnik AG; all rights reserved.

Keep this manual with the product or in a safe place so that it is available for future reference.

d&b audiotechnik AG
Eugen-Adolff-Strasse 134, D-71522 Backnang, Germany
Telephone +49-7191-9669-0, Fax +49-7191-95 00 00
E-mail: docadmin@dbaudio.com, Internet: www.dbaudio.com

Contents

1. Safety precautions.....	4
1.1. Intended use.....	4
1.2. General safety instructions.....	4
1.3. Load capacity/System safety.....	4
1.3.1. ArrayCalc / TI 385.....	4
2. Q-Series array with the Z5159 Q Flying frame.....	5
2.1. Rigging components.....	6
2.1.1. Z5159 Q Flying frame.....	6
2.1.2. Z5155 Q Hoist connector chain.....	6
2.1.3. Z5154 Q Rigging set.....	6
2.2. Preparation for the set up.....	7
2.3. Assembly of the array.....	7
2.4. Alternative set up.....	9
2.5. Final check of the array.....	10
2.6. Hoisting the array.....	10
2.7. Derigging.....	10
2.8. Ground stacks supported by the Q Flying frame.....	10
3. Z5156 Q Flying adapter.....	11
3.1. Load capacity/System safety.....	11
3.2. Suspension of the Q Flying adapter.....	11
3.3. Assembly.....	11
4. Secondary safety.....	12
4.1. Secondary safety at Z5159 Q Flying frame.....	12
4.2. Secondary safety at Z5156 Q Flying adapter.....	13
5. Aiming and securing of the array.....	14
5.1. Horizontal aiming and securing of the array.....	14
5.2. Modifying the vertical aiming of the array.....	14
6. Wind loads.....	15
7. Care and maintenance / Disposal.....	16
7.1. Transport / Storing.....	16
7.2. Visual and functional inspection.....	16
7.3. Disposal.....	16
8. EC Declaration of Conformity.....	17

1. Safety precautions

1.1. Intended use

The Q-Series rigging components must only be used in conjunction with the d&b Q-Series loudspeakers as described in this manual.

Installation and set up should only be carried out by qualified and authorized personnel observing the valid national Rules of Prevention of Accident (RPA).

It is the responsibility of the person installing the assembly to ensure that the suspension/fixing points are suitable for the intended use.

1.2. General safety instructions

All system components must be inspected for faults before use. This also includes the loudspeaker and in particular the rigging sockets of the cabinets.

Damaged components must be withdrawn from use immediately.

Please pay attention to section 7. Care and maintenance / Disposal on page 16 of this manual.

When chain hoists are in operation ensure that there is nobody directly underneath or in the proximity of the load.

1.3. Load capacity/System safety

The Q Flying system (frame and loudspeakers) is designed to suspend a total system weight of 480 kg (1058 lb) Working Load Limit (WLL) according to BGV C1.

The rigging components allow arrays up to a total system weight of 240 kg (527 lb) to be flown in any vertical splay angle configuration.

If the array contains Q-SUB cabinets these must always be positioned at the top of the column.

For arrays with a total system weight of more than 240 kg (527 lb) the load conditions within the rigging components have to be checked using the ArrayCalc array calculator.

Under no circumstances climb on the array.

1.3.1. ArrayCalc / TI 385

The use of ArrayCalc is described in "TI 385 J-Series and Q-Series system design, d&b ArrayCalc" which is supplied with the Q Flying frame. ArrayCalc can be downloaded at www.dbaudio.com.

This TI also includes typical array configurations within the permitted load limits.

Carefully read this TI to become familiar with the operation and behaviour of ArrayCalc and in particular with the mechanical load conditions and limitations.

We also recommend to attend the regularly hosted d&b Q-Series training seminars. Further information of the d&b seminars can be requested directly from d&b audiotechnik sales partners.



WARNING!

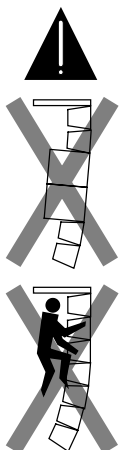

WARNING!

2. Q-Series array with the Z5159 Q Flying frame

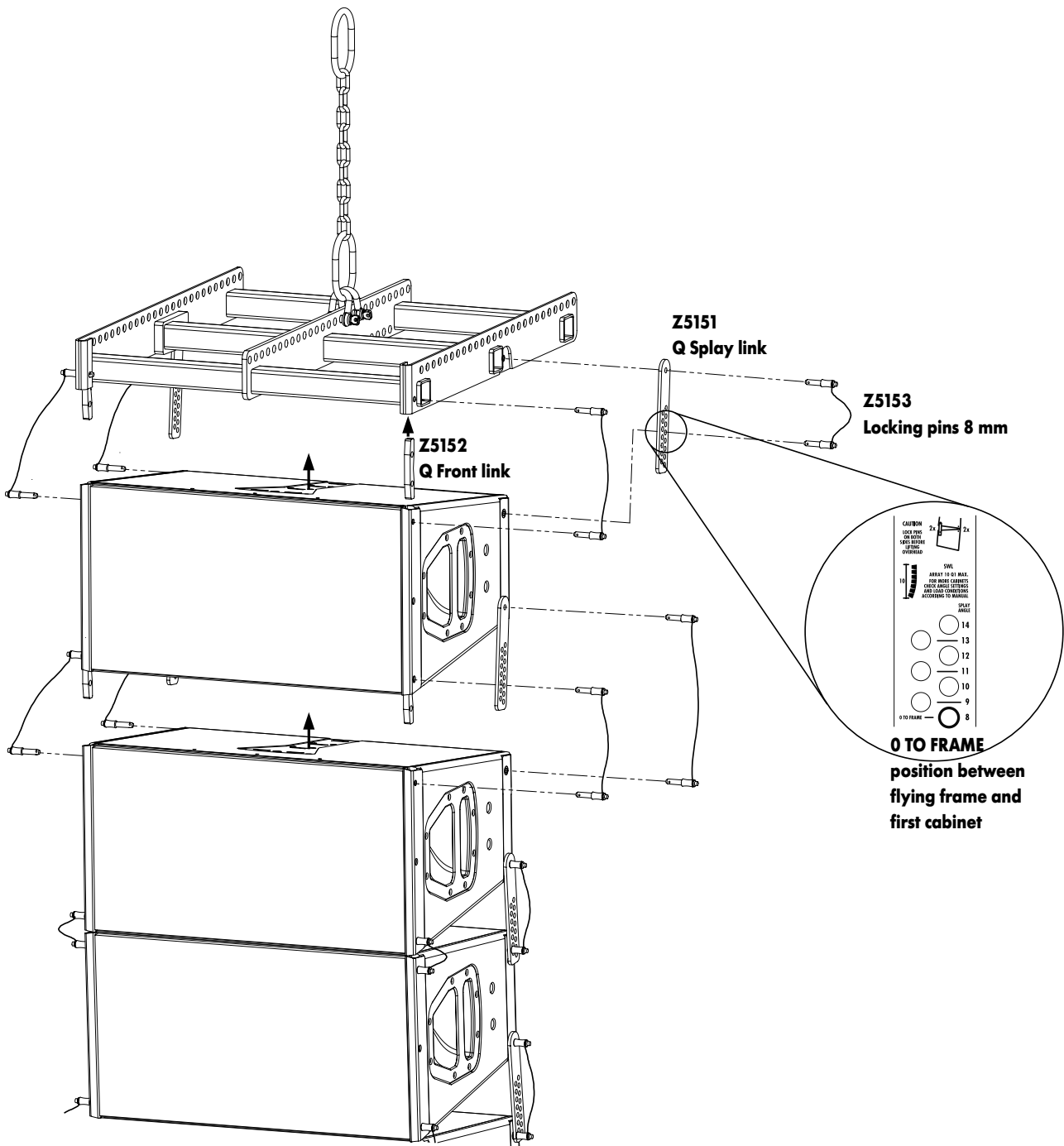

Fig. 1: Q-Series rigging assembly

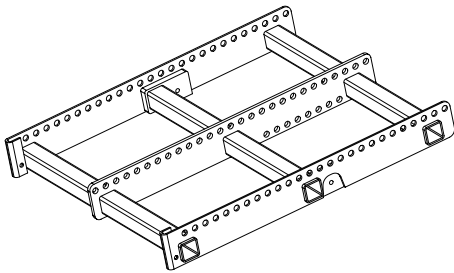

Fig. 2: Z5159 Q Flying frame

2.1. Rigging components

Q-Series arrays suspended by the Z5159 Q Flying frame are assembled using the following rigging components:

2.1.1. Z5159 Q Flying frame

The Z5159 Q Flying frame is designed to support arrays consisting of the following loudspeakers:

Code	Type	Weight incl. array links
Z0510	Q-SUB	42 kg (93 lb)
Z0501	Q1	23 kg (51 lb)
Z0507	Q7	23 kg (51 lb)
Z0511	Q10	23 kg (51 lb)

The weight of the Q Flying frame is 13 kg (29 lb)

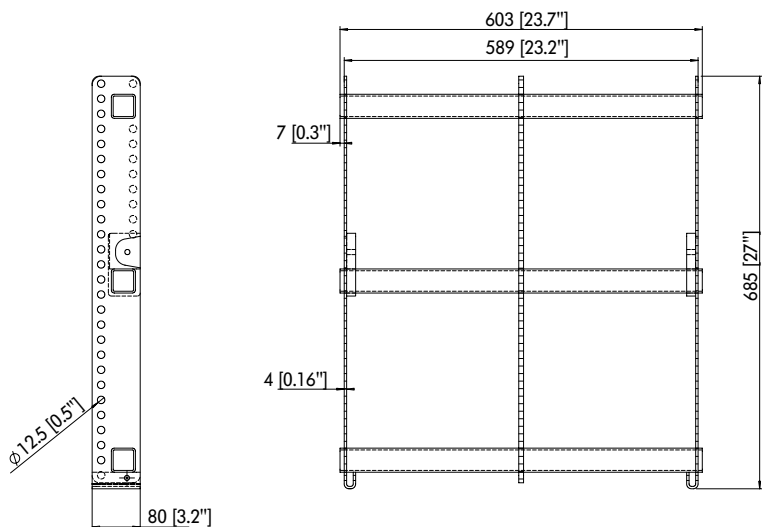

Fig. 3: Z5159 Q Flying frame dimensions in mm [inch]

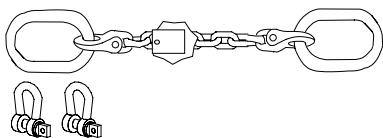

Fig. 4: Z5155 Q Hoist connector chain

2.1.2. Z5155 Q Hoist connector chain

The Z5155 Q Hoist connector chain is used to connect the lifting motor(s) to the Q Flying frame using one or two 1t Shackles supplied with the connector chain. Its length of 52 cm (20.5") allows enough space for the hang of most 1t motor chain containers.

2.1.3. Z5154 Q Rigging set

One set is required for each Q-Series cabinet within a vertical array. The rigging set includes the following components:

- 2 x Z5151 Q Splay link **[a]**
- 2 x Z5152 Q Front link **[b]**
- 8 x Z5153 Locking pins 8 mm (linked in pairs with a steel wire) **[c]**

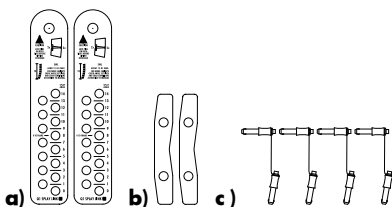

Fig. 5: Z5154 Q Rigging set

2.2. Preparation for the set up

Check the acoustical and mechanical set up with ArrayCalc and prepare enough print outs for each array.

Using the plan, the riggers are able to set up the suspension points, the securing points and the chain hoists.



WARNING!

The working load limit of the chain hoists and their suspension points has to be high enough to carry the total system weight.

If two hoists are used to suspend a single array each of them has to be able to carry the total system weight. This is because during the set up the motors might not always be synchronized.

When on site first clear the working areas, check that the hoists are in the specified position, the chains are not twisted and there is enough clearance to set up and lift the array.

2.3. Assembly of the array

- Prepare flying cables and link cables according to the number of amplifier channels and cabinets used.

Single hoist set up

- Choose the appropriate hole position in the top row of the Q Flying frame centre bar according to the ArrayCalc simulation.

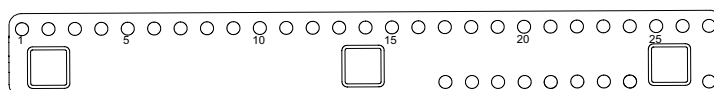

Fig. 9: Q Flying frame hole grid and labelling

- Connect the Z5155 Q Hoist connector chain to the next rounded numbered hole using one E6507 1t Shackle (Fig. 6). If ArrayCalc displays a half numbered hole setting (half grid) use two 1t Shackles set to the adjacent holes (Fig. 7). As an alternative the Z5160 Q Load adapter can be used to achieve a quad grid (Fig. 8). Please refer to the Z5160 Q Load adapter manual.

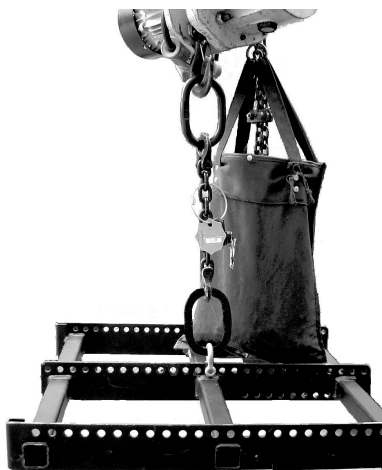

Fig. 6: Hoist connector chain set up

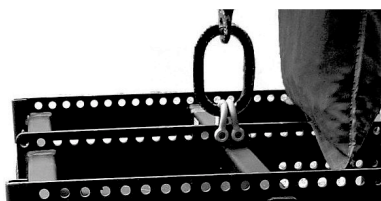

Fig. 7: Half grid using 2 x 1t Shackle

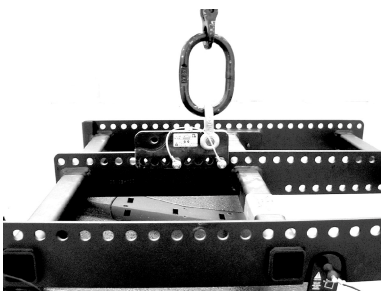

Fig. 8: Quad grid using the Z5160 Q Load adapter

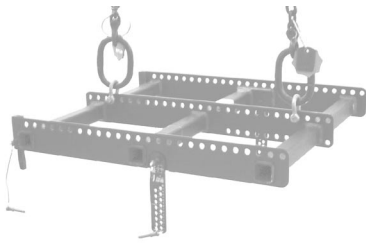

Fig. 10: Dual hoist set up

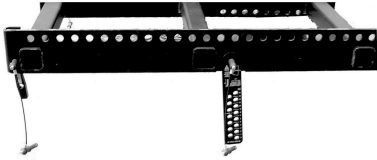

Fig. 11: Front and Splay links connected

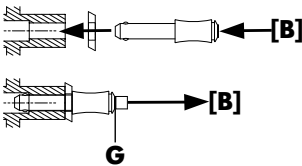

Fig. 12: Locking pin release mechanism



WARNING!

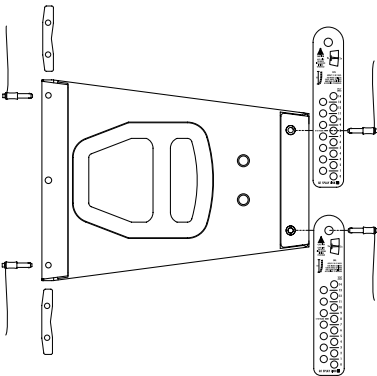

Fig. 13: Splay link setting for first Q1

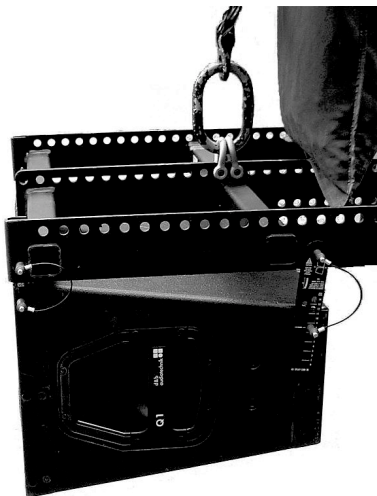

Fig. 14: First cabinet attached

Dual hoist set up

- Using two E6507 1t Shackles connect one Z5155 Q Hoist connector chain to a hole at the front of the Z5159 Q Flying frame centre bar and one to a hole at the back of it (Fig. 10). The vertical aiming of the array will be set by trimming the hoist motors after the array is fully assembled.

Note: For maximum lifting height to be achieved the motors should be connected directly to the lower O-ring of the Hoist connector chain. The chain container will rest on the Q Flying frame however this will not affect the aiming of the array with a dual hoist set up.

- Connect two Z5152 Q Front links and two Z5151 Q Splay links to the Q Flying frame using Z5153 Locking pins 8 mm.

Pressing the button **[B]** releases the locking mechanism allowing insertion through the array links to the sockets of the frame. Releasing the button after the pin is fixed in place the locking mechanism will be locked.

Ensure that the pins are locked. A groove **[G]** (Fig. 12) in the bolt of the pin indicates that it is properly locked.

In order to have all locking pins at hand to connect the next cabinet the pins are linked in pairs with steel wire.

The steel wire between the locking pins is not meant to suspend a cabinet or carry any load. Cabinet weight must only be carried by the Front and Splay links.

- With one person on each side attach the first cabinet. First connect the Z5152 Q Front link on both sides to the upper sockets in the front grill. Then connect the two Z5151 Q Splay links using the 8° hole marked "0 TO FRAME" to the sockets at the rear of the cabinet.
- Attach a cable pick using the bottom row of holes in the centre bar of the Q Flying frame. With a single hoist set up try to suspend the speaker cables right below the lifting position of the Q Flying frame to avoid the aiming of the array being affected by the weight of the cabling. If this is not possible attach the cable pick directly under the chain hoist.

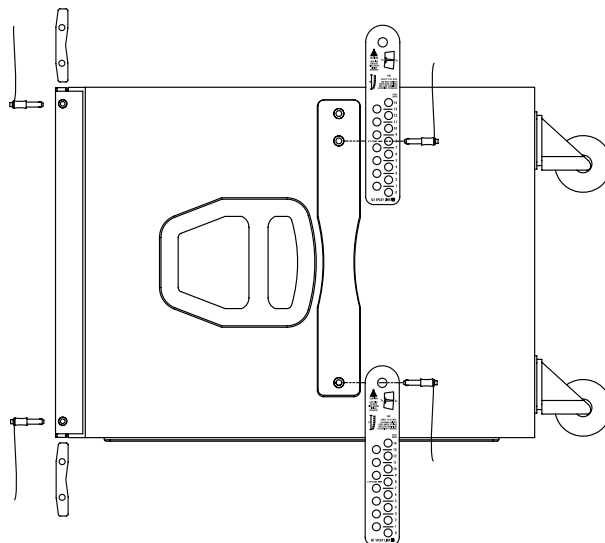

Fig. 15: Splay link setting for first Q-SUB

IMPORTANT!

At the top of each side panel of the Q-SUB cabinet are two sockets one above the other. For flown set ups the lower sockets have to be used, set to "0 TO FRAME" for the first cabinet of the column. The upper socket creates an offset of -6° in respect to the scale on the Splay link. It is used to connect Q-SUB and Q1 cabinets in ground stacked arrays. With the Q Front links rotated by 180° this allows a negative splay angle up to -6° .

Do not apply this to flown arrays.

- The next loudspeaker should be added in the same manner; first attach two Q Front links and two Q Splay links to the bottom of the lowest cabinet of the column and then lift the next cabinet into place.

First connect the Front links. With the Splay links select the hole position according to the splay angles derived from the ArrayCalc simulation. Q-SUB cabinets are generally connected using the 0° splay angle setting.

- Repeat this procedure until the column is complete. Connect all speaker cables when the cabinets are within reach.



Fig. 16: Front and Splay links ready to accept next cabinet



Fig. 17: Select splay angle



Fig. 18: Insert Locking pin 8mm



Fig. 19: 3-deep array

2.4. Alternative set up

Using the chain hoist to pick up the cabinets allows a single person to set up complete columns (without Q-SUBs). Proceed as follows:

- Attach the Q Flying frame to the hoist motor and attach the Front link and Splay links to the Q Flying frame as explained in the previous section.
- Place the Q1 loudspeaker with its face on the ground and lower the hoist until the Splay links can be attached to the cabinet (8° position "0 TO FRAME" to the Q Flying frame). All following cabinets should be set to the required splay angle.
- Lift the loudspeaker using the hoist until it is hanging free and then manually lift and rotate the cabinet to attach the Front links.
- Connect Front and Splay links to the bottom of the cabinet and add the next one in the same manner.

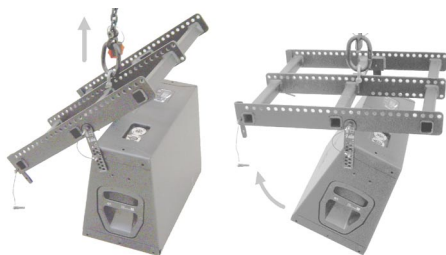

Fig. 20: Array assembly using the chain hoist to lift the cabinets



WARNING!

2.5. Final check of the array

Before lifting the array a visual inspection of the whole system should be carried out.

Ensure all Locking pins 8 mm are inserted and locked securely before lifting the array. The Locking pins 8 mm should only be unlocked for disassembly on the ground.

- Check the wiring. If the amplifiers are already wired and powered on, by using their channel mute switches and a test signal the correct function and routing of all channels and cabinets can be verified.
- With dual hoist set ups check and trim the absolute angle setting of the lowest cabinet using a digital angle finder.

2.6. Hoisting the array

When all the mechanical adjustments, system checks and safety checks have been made the array can be hoisted up to its operating position.

When hoisting the array, ensure that the loudspeaker cables do not get caught anywhere. The cables can be strapped together with the motor cable to form a loom while the system is hoisted.

The chain hoist motors must raise the system slowly and evenly so that it is held level and does not swing or move from side to side during hoisting.

For safety reasons the final array must be fitted with an additional safety device which is independent of the suspension points. A detailed description is given in section 4. Secondary safety on page 12.

2.7. Derigging

To lower the array and dismantle it, follow the assembly instructions in reverse order. The same safety instructions apply.

2.8. Ground stacks supported by the Q Flying frame

Ground stacked set ups must always be secured against movement and possible collapse.

Up to six Q1 cabinets can be stacked and interlinked using the standard Q rigging components and the Z5159 Q Flying frame as ground support.

- Check the acoustical and mechanical set up with the ArrayCalc for stacked set ups. In particular watch the position of the array's centre of gravity displayed in the side view.
- Place the Q Flying frame up side down on the ground as shown in the illustration opposite (Fig. 21).
- Add Q1 cabinets one by one using the Z5151 Q Front links, Z5152 Q Splay links and Z5153 Locking pins 8 mm.

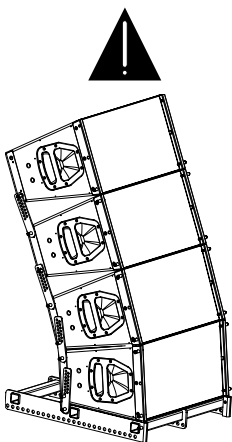

WARNING!

Fig. 21: Q1s in a ground stacked set up on Z5159 Q Flying frame

3. Z5156 Q Flying adapter

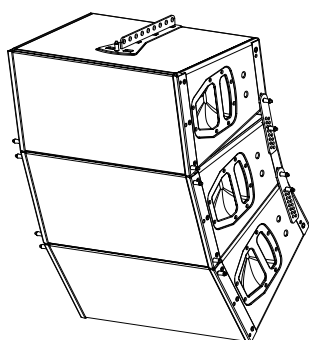

Fig. 22: 3 x Q1s with Z5156 Q Flying adapter

The Z5156 Q Flying adapter is designed to support arrays of up to three of the following types of loudspeakers:

Code	Type	Weight incl. array links
Z0501	Q1	23 kg (51 lb)
Z0507	Q7	23 kg (51 lb)
Z0511	Q10	23 kg (51 lb)

The weight of the Q Flying adapter is 2.2 kg (4.9 lb)



WARNING!

3.1. Load capacity/System safety

The Z5156 Q Flying adapter is designed to suspend up to three d&b Q1, Q7 or Q10 loudspeaker cabinets. The Working Load Limit (WLL) for the adapter is 72 kg (159 lb).

Make sure that the Working Load Limit (WLL) of the suspension point is high enough to carry the total system weight.

3.2. Suspension of the Q Flying adapter

The Q Flying adapter is equipped with nine locating holes 12.5 mm (0.5") at 30 mm (1.2") spacings. With arrays up to three cabinets ArrayCalc displays the Q Flying adapter hole position to achieve the desired vertical aiming.

The Q Flying adapter can be suspended using an E6502 1t Shackle and steel wire ropes or the Z5147 Rota clamp. Choose the appropriate hole position in the Q Flying adapter according to the ArrayCalc simulation.

3.3. Assembly

The Z5156 Q Flying adapter is connected to the quick lock adapter plate of the first cabinet as follows (Fig. 38):

- Attach the Q Flying adapter's fixing plate into the recessed holes in the cabinets quick lock adapter plate.
- Slide the adapter towards the back of the cabinet until it is fixed in place.
- Insert the securing pin [S] into the aligned socket.
- **Ensure that the securing pin [S] is locked.** A groove [G] in the bolt of the securing pin indicates that it is properly locked.
- Connect up to two more cabinets using Z5151 Q Front links, Z5152 Q Splay links and Z5153 Q Locking pins 8 mm as described in section 2.3 Assembly of the array on page 7.
- For safety reasons the final array must be fitted with an additional safety device which is independent of the suspension points. A detailed description is given in section 4. Secondary safety on page 12.

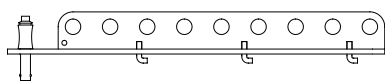

Fig. 23: Q Flying adapter hole grid

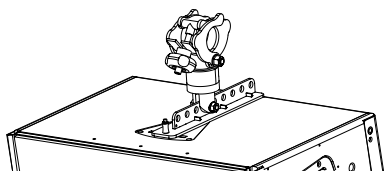

Fig. 24: Q Flying adapter and Z5147 Rota clamp

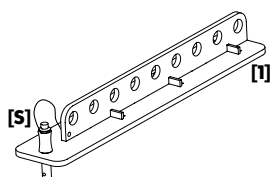

Fig. 25: Q Flying adapter [1] and securing pin [S]

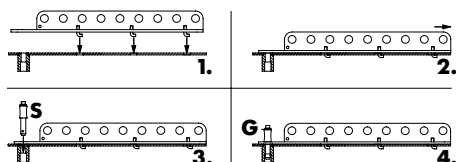

Fig. 26: Q cabinet quick lock mechanism

4. Secondary safety



WARNING!

The secondary safety suspension must be independent of the primary suspension points and capable of carrying the total system weight including all dynamic forces in case of a failure of the primary suspension.

The additional safety device must be mounted in a way that the array is caught by the safety device without significant drop and swing in the event that the primary suspension fails. For this reason the safety wire should suspend the array right above its centre of gravity.

4.1. Secondary safety at Z5159 Q Flying frame

The secondary safety can be attached in different ways using a 2-leg safety wire (Fig. 27) connected to the Q Flying frame.



Fig. 27: 2-leg safety wire with shackles

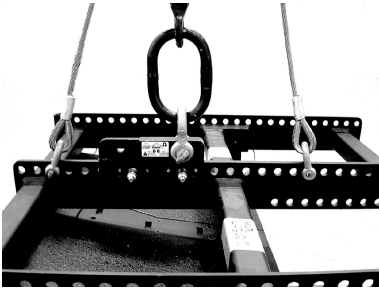

Fig. 28: Secondary safety - Type 1

Type 1 - single hoist set up only

Connect the shackles of the safety wire to the centre bar of the Q Flying frame using hole positions as equally distanced from the pickup point as possible (Fig. 28).

Type 2 - single or dual hoist set up

Connect the shackles of the safety wire to the outer bars of the Q Flying frame using hole positions in line with the centre of gravity (pickup point - Fig. 29a). The shackles may also be placed diagonally around the pickup point - Fig. 29b.

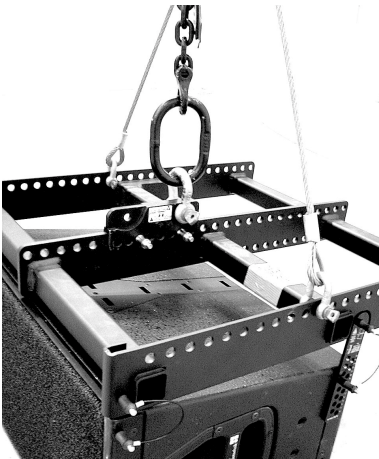

a)

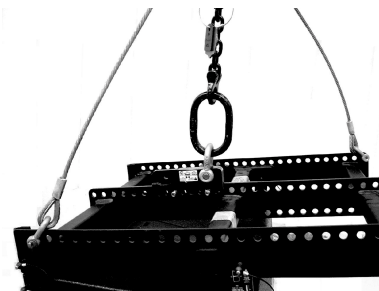

b)

Fig. 29: Secondary safety - Type 2



WARNING!

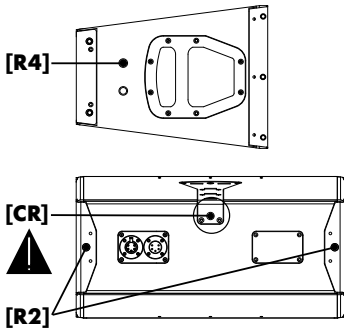

Fig. 30: Sockets for secondary safety

4.2. Secondary safety at Z5156 Q Flying adapter

Do not connect the secondary safety to the centre socket [CR] (Fig. 30) at the back of the cabinet. This socket is intended for horizontal aiming of an array and limited to a load of 50 kg (110 lb).

The secondary safety should be applied to the top cabinet of the array. Use two Z5048 Flying pins 10 mm connected to the sockets [R2] at the rear of the cabinet or two Q9032 M10 Safety eye bolts attached to the threaded inserts [R4] on both sides of the cabinet, passing the steel rope through the Flying pins or the Safety eye bolts and attaching it to the securing pickup point.

5. Aiming and securing of the array

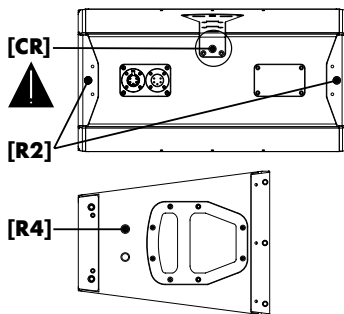

Fig. 31: Rigging sockets for horizontal aiming and securing against rotation and swing



WARNING!

5.1. Horizontal aiming and securing of the array

After the array has been lifted to its operating height the horizontal aiming has to be set and the array should be secured against rotation and swing. It is recommended to use the following rigging sockets on the lowest cabinet:

- Sockets [R2] or [CR] with Z5048 Flying pins 10 mm.
- M10 threaded inserts [R4] with Q9032 M10 Safety eyebolts.

If the system is used in an open air environment the influence of wind has to be taken into account. The protection against rotation and swing has to withstand higher forces. Do not secure the array with the centre socket [CR] (Fig. 31) at the back of the cabinet. This socket is limited to a load of 50 kg (110 lb).

Read the following section 6. Wind loads.

5.2. Modifying the vertical aiming of the array

If an application requires the array to have a vertical angle which is not possible by a single suspension within the hole grid of the Q Flying frame additional wires or hoists may be needed to achieve this.

With arrays of up to three cabinets the standard rigging sockets on the cabinets may be used (Fig. 31).

To angle an array of more than three Q-Series cabinets an additional Z5159 Q Flying frame has to be attached to the lowest cabinet of the column. All additional wires or hoists have to be connected to the Q Flying frame and not to the cabinets rigging sockets (Fig. 31).

Always pull the additional wires or hoists backwards and upwards (Fig. 32).

Using additional wires or hoists will change the load conditions within the array and its rigging components. The load calculation of ArrayCalc will not apply any more. Therefore increasing the vertical angle of an array is only possible with columns up to a total system weight of 240 kg (527 lb).

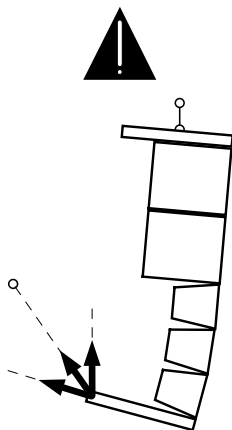

Fig. 32: Applying a second Q Flying frame to increase the vertical angle of the array

6. Wind loads

When loudspeaker arrays are flown in an open air environment, possible wind effects should be taken into account. Wind load will produce additional dynamic forces to the rigging components and the suspension, which may lead to a dangerous situation.



WARNING!

Generally flying loudspeakers overhead at wind forces higher than 6 bft is not recommended.

When planning an open air event it is essential to get current weather and wind information.

The following wind speed scale according to Beaufort gives an impression of the effects of the different wind forces (bft).

bft	knots	km/h	mph	Description	Effects on land
0	0-1	0-1	0-1	Calm	Smoke rises vertically.
1	1-3	1-5	1-3	Light Air	Direction of wind shown by smoke drift, but not by wind vanes.
2	4-6	6-11	4-7	Light breeze	Wind felt on face; leaves rustle; ordinary vanes moved by wind.
3	7-10	12-19	8-12	Gentle breeze	Leaves and small twigs in constant motion; wind extends light flag.
4	11-16	20-28	13-18	Moderate breeze	Raises dust and loose paper; small branches are moved.
5	17-21	29-38	19-24	Fresh breeze	Small trees in leaf begin to sway; crested wavelets form on inland waters.
6	22-27	39-49	25-31	Strong breeze	Large branches in motion; whistling heard in telegraph wires; umbrellas used with difficulty.
7	28-33	50-61	32-38	Near gale	Whole trees in motion; inconvenience felt when walking against the wind.
8	34-40	62-74	39-46	Gale	Breaks twigs off trees; generally impedes progress.
9	41-47	75-88	47-54	Severe gale	Slight structural damage occurs (chimney-pots and slates removed).
10	48-55	89-102	55-63	Storm	Trees uprooted; considerable structural damage occurs.
11	56-63	102-117	64-72	Violent storm	Accompanied by wide-spread damage.
12	> 64	> 117,0	> 72	Hurricane	Heaviest damage and destruction.

Tab. 1: Wind force and its effects on land

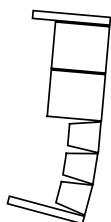

Fig. 33: Securing the array using a second Q Flying frame

WARNING!

If according to the forecast wind forces higher than 5 bft are possible the following actions have to be taken:

- **The actual on site wind speed has to be monitored permanently. Be aware that wind speed typically increases with height above ground.**
- **Suspension and securing points of the array should be designed to accommodate double the static load in order to withstand any additional dynamic forces.**
- **Arrays with more than three cabinets have to be secured using a second Q Flying frame at the bottom of the column. Wires or ropes have to be connected to the Q Flying frame and not to the cabinets rigging sockets (Fig. 33).**



WARNING!

If the wind force exceeds 8 bft there is a risk of mechanical damage to the components which may lead to a dangerous situation for persons in the vicinity of the flown array.

Stop the event and make sure that no one is left within the vicinity of the array.

Lower down and secure the array.

7. Care and maintenance / Disposal

7.1. Transport / Storing

During transport ensure the rigging components are not stressed or damaged by mechanical forces. Use suitable transport cases.

Due to their surface treatment the Q-Series rigging components are temporary protected against moisture. However, ensure the components are in a dry state while stored or during transport and use.

7.2. Visual and functional inspection

Cabinet enclosure:

- Visual inspection of all fitting plates including the Quick lock adapter plate **[R3]** and front grills for obvious damage (e.g. cracks or corrosion).
- Inspection of all fitting plates including front grills to ensure they are securely attached.
- Using new pins perform a functional inspection of the Locking pin sockets **[R1]** and for the Flying pin sockets **[R2/CR]**
- Inspection of the M10 threaded inserts **[R4]**.
- Regularly lubricate the sockets and threaded inserts with WD-40® or a similar product.

Z5153 Locking pins

- Visual inspection regarding deformation and corrosion of the component.
- Inspection for missing ball bearings and damage.
- Functional inspection of the ball bearings.
- Functional inspection of the release mechanism to check it functions properly.

Z5151 Q Splay and Z5152 Q Front links

- Visual inspection regarding deformation and damage (e.g. cracks and corrosion) including all holes of the component.

Z5159 Q Flying frame, Z5156 Q Flying adapter

- Visual inspection regarding deformation and damage (e.g. cracks and corrosion) including all holes of the component.

Z5155 Hoist connector chain / Z5048 Flying pin

- Inspection according to the appropriate regulations for lifting devices.

7.3. Disposal

When out of use the rigging components must be disposed in accordance to the national environmental regulations.

Ensure that damaged rigging components are disposed in a way that they can not be used again.

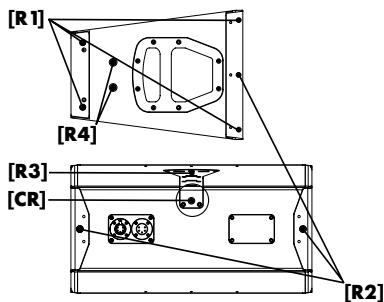

Fig. 34: Q1/7/10 rigging sockets

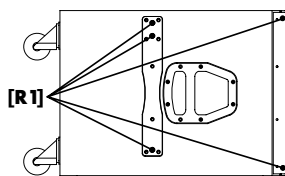

Fig. 35: Q-SUB rigging sockets

8. EC Declaration of Conformity

within the meaning of the EC Machine Directive 98/37/EEC

We hereby declare that the equipment designated below is designed and built in the version sold by us in such a way as to comply with the relevant fundamental safety and health criteria of the applicable EC Directive(s). This declaration shall cease to be valid if alterations are made to the equipment without our prior agreement.

This declarations covers:

- **d&b Z5159, Q Flying frame together with:**
 - **d&b Z5151, Q Splay Link**
 - **d&b Z5152, Q Front Link**
 - **d&b Z5153, Locking pins, 8 mm**
 - **d&b Z5155, Q Hoist connector chain**

- **d&b Z5156, Q Flying adapter together with:**
 - **d&b Z5151, Q Splay Link**
 - **d&b Z5152, Q Front Link**
 - **d&b Z5153, Q Locking pins, 8 mm**

Relevant EC Directives:

EC Machine Directive 98/37/EC

National standards and technical specifications applied, in particular:

DIN EN ISO 12100, DIN 1050, BGV C1

Backnang 2007-02-08



(Frank Bothe, Director)

