

**ALLEN&HEATH**

**QU-SB**

**RK19 Rack Mount Kit**



# Installing Qu-SB

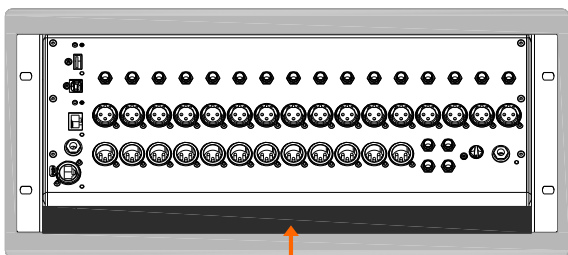
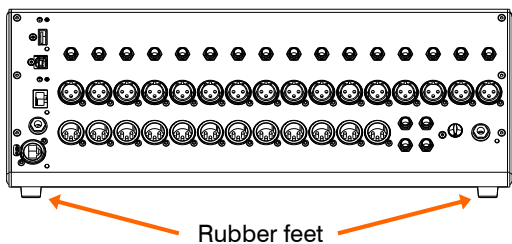

**Free standing** - For operating while on a stage or other flat surface. Make sure the 4 rubber feet are fitted.

**i** - Allow space around the unit for ventilation. Run the cables to avoid a trip hazard.

The mixer should be transported in a purpose designed padded bag or flight case.

**Rack Mounted** - For operating while fitted into a 4U space in a standard 19" equipment rack or flight case. The front panel is angled upwards to allow easier access to plug in the cables. A gap underneath the unit lets you feed cables through from within the rack.

Rack mounting option kit **QU-SB-RK19** is available from Allen & Heath.

**i** - Ensure adequate air flow. Do not block the rear ventilation slots or the gap underneath the front of the unit.

To save space a 'shallow' case with internal depth of 200mm (8") or more is recommended.

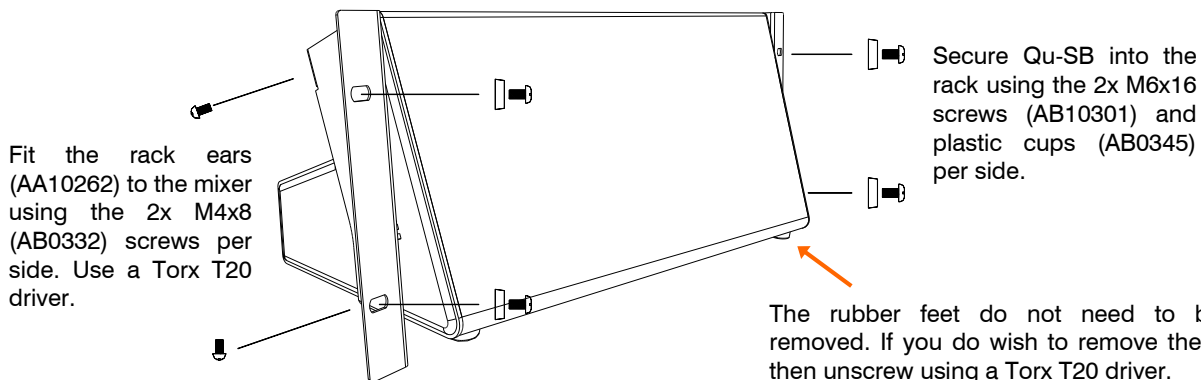

## Dimensions - Shown in millimetres (inches)

