

# DR<sup>128</sup>

W H E N   Y O U ' R E   M I X I N G   W I T H   P R O F E S S I O N A L S



---

24 bit Digital Mix Processor

---

12 in 8 out Audio System

---

PC configuration software

**ALLEN**  
**&**  
**HEATH**

# INTRODUCTION

**THE DR128 IS A 12 INPUT, 8 OUTPUT DIGITAL AUDIO MIX PROCESSOR CREATED FOR THE MODERN SYSTEMS DESIGNER. SOPHISTICATED INSTALLATIONS REQUIRING FULL MATRIX MIXING, PROCESSING AND ZONING ARE EASILY ADDRESSED BY THIS SINGLE 2U UNIT.**

**THE DR128 CUTS DOWN ON VALUABLE SETUP TIME AND RACK SPACE. MIX, GAIN, LEVELS, GATES, COMPRESSORS, GRAPHIC EQ'S, PARAMETRIC EQ'S - ALL COMBINED USING THE DR128's DIGITAL ARCHITECTURE, WITH NO COMPLEX WIRING. CUSTOM CONFIGURATION THROUGH WinDR SOFTWARE ALLOWS QUICK, FLEXIBLE SYSTEM DESIGN. ONCE CONFIGURED, NO PC IS NEEDED FOR OPERATION. A SIMPLE, TAMPER-PROOF FRONT PANEL PROVIDES A SIMPLE USER INTERFACE.**

**AT EVERY STEP THE SYSTEM DESIGNER HAS THE CHOICE. SIGNAL PROCESSING OPTIONS CAN BE SELECTED FOR EACH OF THE 12 INPUTS AND 8 OUTPUTS. EVEN FRONT PANEL KEYS CAN BE INDIVIDUALLY CONFIGURED AS ANYTHING FROM SIMPLE VOLUME CONTROLS TO SYSTEM CONFIGURATION CHANGES. THE DR128 IS A COMPACT SOLUTION FOR A WHOLE RANGE OF INSTALLATIONS, REDEFINING PERFORMANCE AND VALUE IN JUST 2U.**

## DR128 - THE TECHNOLOGY INSIDE

The DR128 excels by moulding sophisticated electronics into a solution that is simple but powerful. We hand-picked the best existing technologies and blended these with some important innovations. In all of this, the focus was kept firmly on the needs of the systems designer.

## THE BEST MIX

The DR128 employs the best mix of different technologies to give you a supreme solution. The circuitry uses both conventional and surface-mount components for compactness and reliability. The power supply is a mix of switched-mode and linear topologies, giving the unit the ability to run from a single 24V battery backup in the event of a mains failure (conforming to BS5839). The advanced memory management at the digital heart of the system uses a mixture of DRAM and Flash memory, the latter enabling remote firmware upgrades via the RS232 port, eliminating the need for chip swapping.

## INNOVATION TO EXCELLENCE

When our ideas began to exceed the available technology, we decided to move the technology forward. In conjunction with our sister companies in the Harman Group, we developed the T-MIX ASIC (Application Specific Integrated Circuit).



This powerful device provides the crucial interface between the DSP 'brain' of the unit and the input and output circuits. There are two ASIC+DSP Processing Engines (PE) in each DR128 as standard. The first PE handles all mixing, level control, phase, metering and output limiting, while the second PE executes a powerful selection of signal processing 'palettes' that can be configured and positioned as defined by the installer. It is this unique architecture that defines the DR128 as an exceptional tool.

## THE BENEFITS

The system channels the technology into a unit that is flexible, easy-to-use and supremely capable. The DR128 provides safety and security with its battery backup, tamper-proof function keys, password access and alarm system integration. The unit also incorporates a

real-time clock for timed events. In short, the technology does the work for you, making both installation and operation quick and easy.

- **Cost effective solution to complex audio matrix systems**
- **Digital processing architecture allowing custom system design**
- **8 outputs with 8 mic/line and 4 line inputs**
- **WinDR System Manager configuration software**
- **Stand-Alone operation with simple user controls**
- **Password protected setup**
- **Many resources available: Ducking, gates, mix, level, limiter, Parametric EQs, graphic equaliser etc**
- **Designed to meet BS5839 installation requirements**
- **Custom Digital technology with 24 bit conversion**
- **DSPx Expander option provides an additional 2 PEs for greater signal processing capability. 2 DSPx options can be fitted.**
- **DSPd Delay option provides up to 0.66s of delay on every output**

**THE DR128 CAN BE SET UP USING  
PC COMPATIBLE WinDR SOFTWARE**

# DR128

Simply connect the PC to the DR128 unit and run the WinDR System Manager application. WinDR interrogates any DR128 unit attached for its configuration. Various functions of the system can then be viewed and edited as required.

For example, Resource Palettes are selected to suit the application. This provides a toolbox of audio processing

blocks, e.g. Graphic or Parametric EQs that can be dragged onto the required Input or Output channels. The resource then appears as an icon in the channel strip.

Once allocated, a simple click on the icon creates a window where the resource can be viewed and modified.

Different variations of the resource

palettes can then be stored in patches on disk or downloaded to the DR128.

In addition to the Resource Palettes, all DR128 functions can be easily configured from WinDR i.e. Crosspoint Mix Matrix, Ducker, Password & Security, Function Key assign, Remote Switch Event assign, Time/Date.

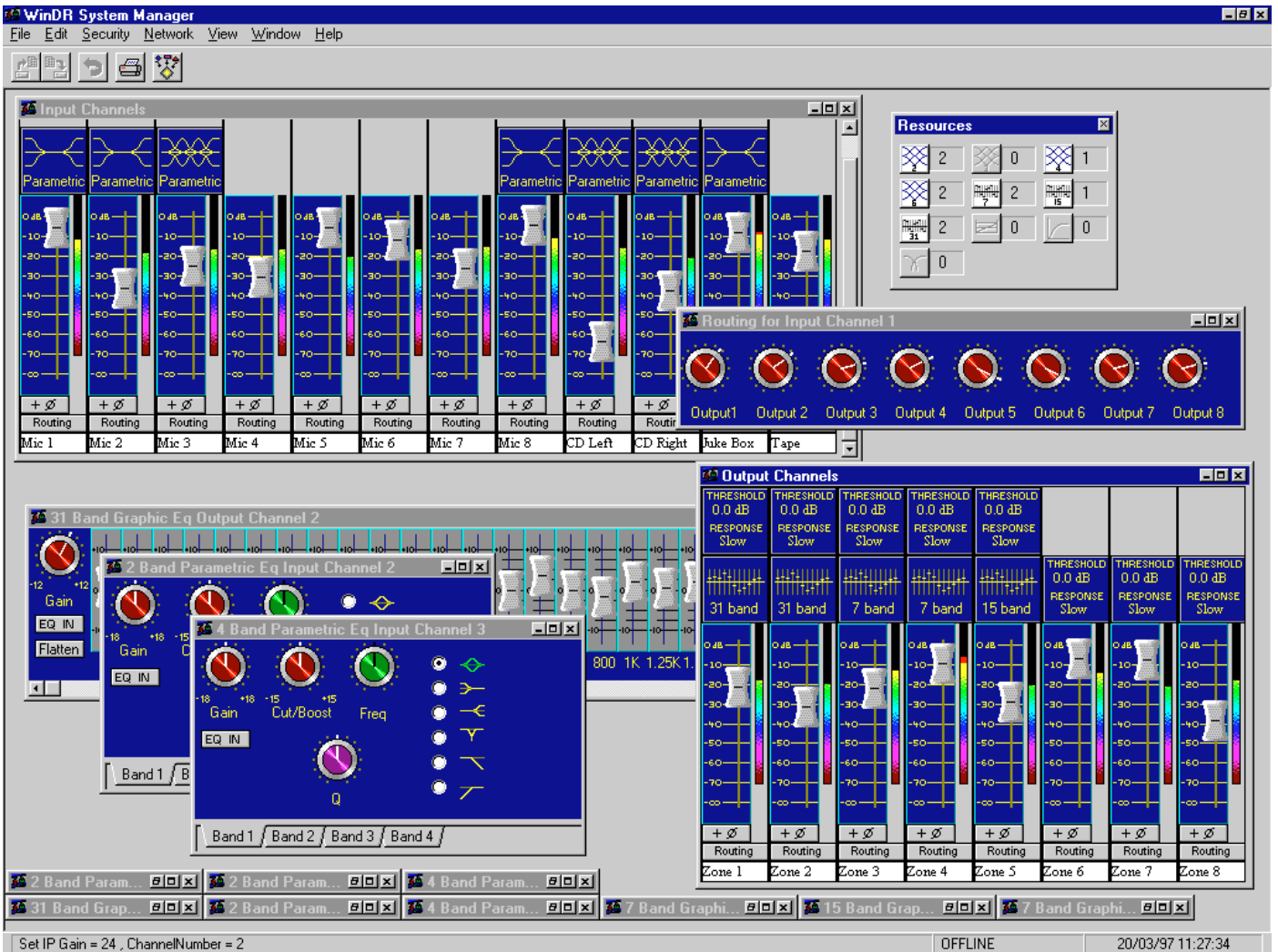

- 32-bit Windows 95™ application
- Communicates with DR128 via PC's serial port using an AES-24 ready, object-oriented communications protocol
- Can be run On-Line or Stand-Alone for remote system configuration
- On-Line connection provides real-time control and monitoring of all DR128 functions
- Allows configuration and archiving of installation setups

For more information on WinDR software, check out the Allen & Heath website.

Region for allocating Palette Resources.  
 Click on channel resource to view and edit.  
 Note: All 8 Outputs have limiters assigned to them as default.  
 Real-time signal meters on all inputs and outputs.

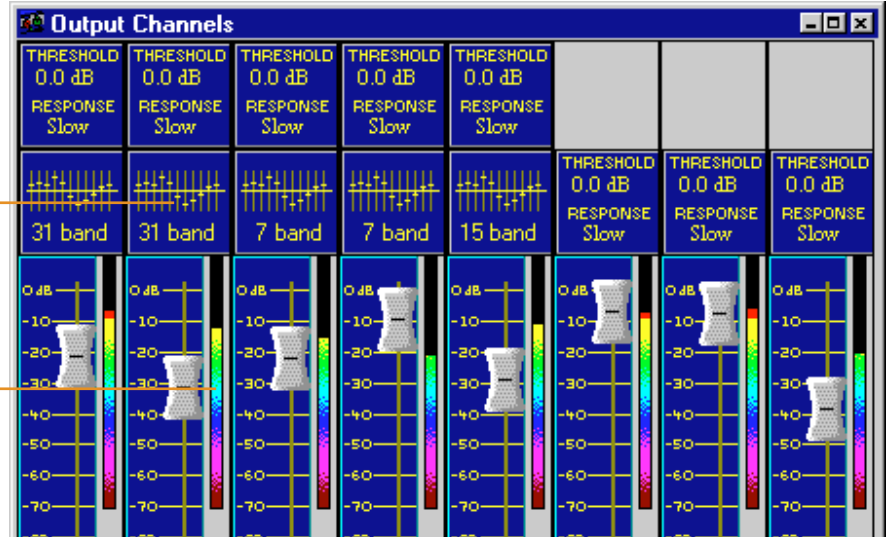

Region for naming input and output channels.



**RESOURCE PALETTES**  
 To optimize the Digital Signal Processing power provided in the DR128, audio signal processing elements are provided in Resource Palettes.

Resource Palettes provide 'toolboxes' containing the audio processing blocks required for particular applications.

Each palette contains a certain number of Graphic EQs Parametric EQs & Gates, etc. that can be allocated to input channels as required. Each Processing Engine can be allocated its own Resource Palette.

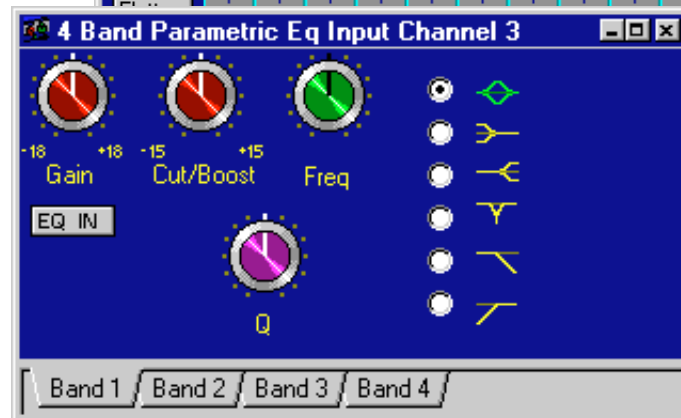

Resource icon - drag and drop onto channel strip to allocate. Number indicates unallocated resources remaining.

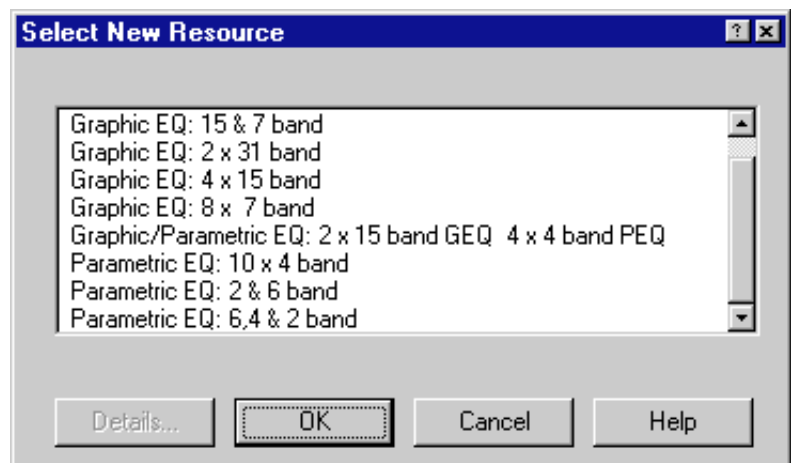

EXAMPLE APPLICATIONS

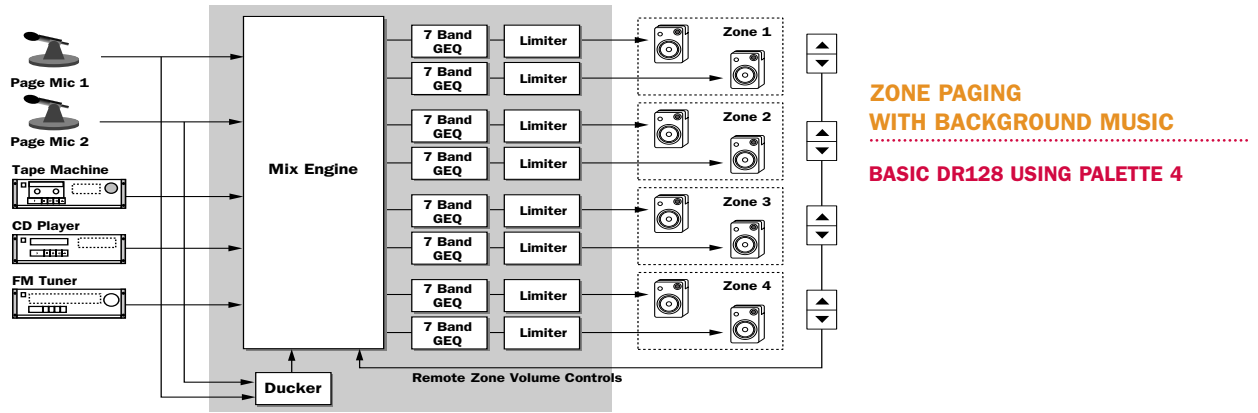

**ZONE PAGING  
WITH BACKGROUND MUSIC**

**BASIC DR128 USING PALETTE 4**

**THEME PUB/KARAOKE BAR**

**DR128 WITH DSPx EXPANDER  
USING PALETTES 6, 10, 15**

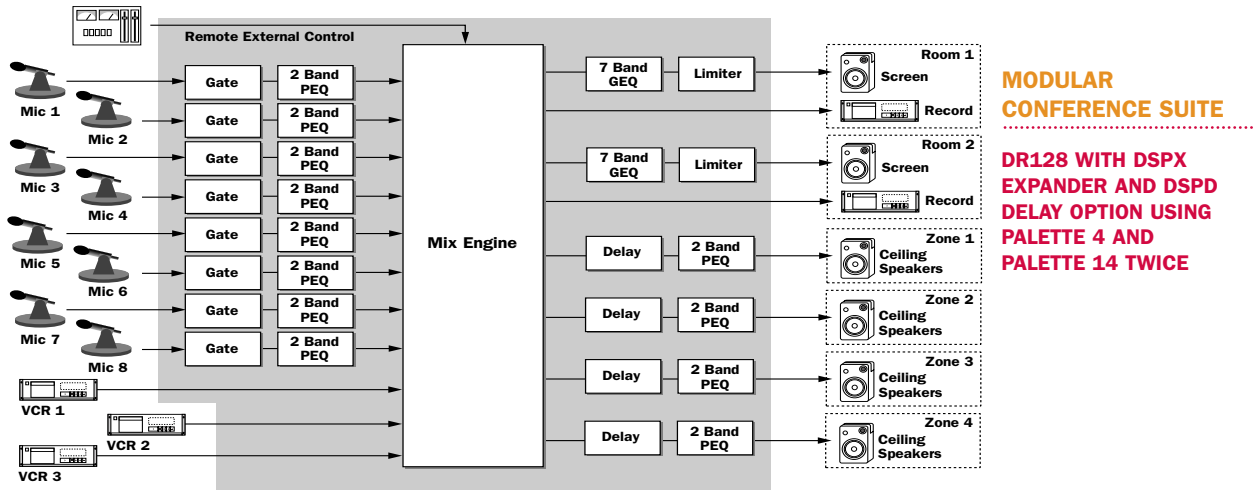
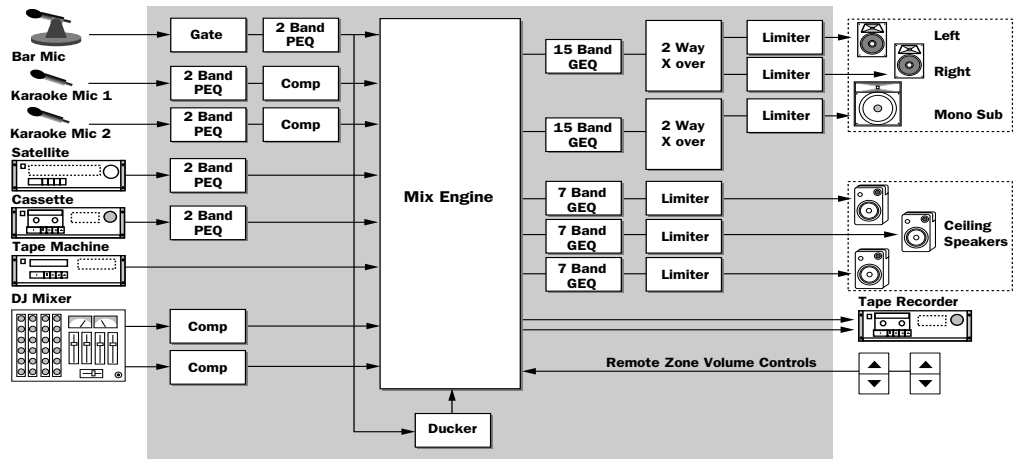

**MODULAR  
CONFERENCE SUITE**

**DR128 WITH DSPx  
EXPANDER AND DSPD  
DELAY OPTION USING  
PALETTE 4 AND  
PALETTE 14 TWICE**

**Resource Notes**

**GEQ** Graphic Equalizer available in 7, 15 & 31 Band configurations. **PEQ** Parametric Equaliser available in 2, 4, 6, 8 Band configurations. **GATE** Noise Gate with controls for Attack, Release, Hold, Threshold, & Gain Reduction. **COMP** Compressor with controls for Threshold, Ratio, Soft Knee, Attack/Release & Make-up gain. **XOVER** 4th order Crossover filters available in 2-way & 3-way configurations.

PALETTE	RESOURCE	QTY
1	7 BAND GEQ	4
	15 BAND GEQ	2
2	31 BAND GEQ	2
3	15 BAND GEQ	4
4	7 BAND GEQ	8
5	15 BAND GEQ	2
	4 BAND PEQ	4
6	15 BAND GEQ	2
	2 BAND PEQ	8
7	4 BAND PEQ	10
8	2 BAND PEQ	8
	6 BAND PEQ	4
9	2 BAND PEQ	6
	4 BAND PEQ	4
	6 BAND PEQ	2

PALETTE	RESOURCE	QTY
10	2 WAY XOVER	4
	7 BAND GEQ	4
11	3 WAY XOVER	2
	7 BAND GEQ	4
12	3 WAY XOVER	2
	7 BAND GEQ	2
	4 BAND PEQ	4
13	GATE	6
	4 BAND PEQ	6
14	GATE	6
	2 BAND PEQ	12
15	GATE	12
	COMP	4
16	COMP	4
	4 BAND PEQ	4

**OTHER TYPICAL APPLICATIONS**

- Hotels
- Conference Centres
- Houses of Worship
- Theme Parks
- Stadia
- Distance Learning Suites
- Law Courts
- Installed public address
- Stage monitor processor and more...



## DR128 SPECIFICATIONS

**0dBu = 0.775 VOLTS RMS**  
**0dBV = 1 VOLT RMS**  
**0dBV = 0dBFS**

INPUTS	CONNECTOR			IMPEDANCE	GAIN
MIC IN	X8	XLR	PIN2+,3-	BALANCED	VARIABLE 18 TO 60dB
LINE IN	X4	DUAL RCA	PAD SELECTED	2K ohm	VARIABLE -4 TO 38dB
			UNBALANCED	10K ohm	VARIABLE -10dBV TO +4dBu (INTERNAL)
			PHONO A&B MONO-SUMMED	10K ohm	
OUTPUTS					
OUTPUT	X8	XLR	PIN2+,3-	BALANCED	VARIABLE -10dBV TO +4dBu (INTERNAL)

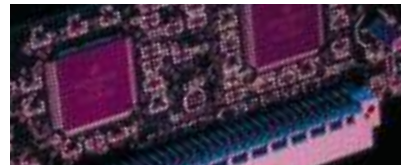

OTHER		
RS-232	X1	9 WAY D FEMALE 56KBAUD
REMOTE SWITCH	X8	9 WAY D FEMALE OPTO-ISOLATED TO 2.5KV
DC POWER BACKUP	X1	+24V (+/-15%) @ 3.5 AMPS MAX

INTERNAL HEADROOM	+15dBu	AC POWER REQUIREMENTS	FACTORY WIRED FOR 100, 120, 220, 230V AC
MAXIMUM OUTPUT LEVEL	+16dBu INTO 600 ohms	50/60Hz MAINS INPUT	FUSE T315mA (220V - 240V AC)
FREQUENCY RESPONSE	+/-1dB 20Hz TO 20kHz	DC POWER BACKUP	EXTERNAL DC POWER SUPPLY INPUT
DISTORTION	THD BETTER THAN 0.004% @ 1kHz	NOMINAL +24V DC (+/- 15%)	FUSE 5A (INTERNAL)
CROSSTALK	INTERCHANNEL > -80dB AT 1kHz	DIMENSIONS	486 X 380 X 89 mm
NOISE 22Hz - 22kHz	MIC EIN -128dB (150 ohms source)	UNPACKED WEIGHT	9.5kg
	LINE PREAMP AT 0dB GAIN -90dBu	PACKED WEIGHT	10kg
	MIX NOISE (ALL ROUTED) > -80dBu	ADC	24-BIT FS X 128 Σ-Δ
PANEL METERS	2 COLOUR: RED: PEAK -6dB dBFS GREEN: SIGNAL -42dB dBFS	DAC	20-BIT FS X 128 Σ-Δ
PHANTOM POWER	+15V, INTERNAL JUMPER LINKS	PROCESSING	2 X MOTOROLA 56002 24-BIT FIXED POINT
POWER REQUIREMENTS	50/60Hz 70W MAX	SAMPLING FREQUENCY	48kHz
POWER SUPPLY	MAINS VOLTAGE SET FOR LOCAL REQUIREMENTS		
POWER CONSUMPTION	INTERNAL REGULATED HYBRID SWITCH MODE/LINEAR 70VA MAX		

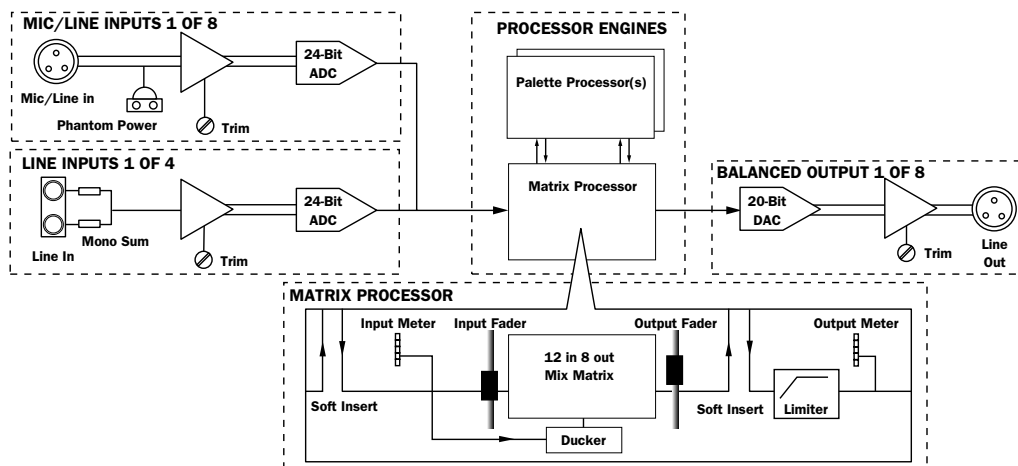

**ALLEN & HEATH**  
 Kernick Industrial Estate, Penryn, Cornwall TR10 9LU.  
**Tel: (+44) 01326 372070 Fax: (+44) 01326 377097**  
<http://www.allen-heath.com>



The DR128 complies with the European Directives for Electromagnetic Compatibility 89/336/EEC & 92/31/EEC



A Division of Harman International Industries Limited